

BUREAU OF INDIAN STANDARDS

DRAFT FOR COMMENTS ONLY

(Not to be reproduced without the permission of BIS or used as an Indian Standard)

Draft Indian Standard

**CODE OF PRACTICE FOR DESIGN, INSTALLATION AND MAINTENANCE OF
SERVICE LINES UP TO AND INCLUDING 650 V a.c.**

(ICS 91.140.50)

Electrical Installation

Last date for Comments – 10/10/2024

Sectional Committee, ETD 20

FOREWORD

(Formal clause will be added later)

This code applies to service lines for voltages up to and including 650 V a.c. for all types of residential, commercial, industrial and multi-storied buildings in urban and rural areas.

This standard was first published in 1976. This revision has been brought out to bring the standard inline with the latest industry practices.

This edition includes the following significant technical changes with respect to the previous edition:

- a) Definitions for terms such as Electric Supply Code, Licensee, high-rise buildings, Mains, etc., have been included.
- b) Requirements related to *The Electricity Act, 2003* and the *Central Electricity Authority (Measures relating to Safety and Electric Supply) Regulations, 2023* have been mentioned in place of the *Indian Electricity Act, 1910*, which was referenced in the earlier standard.
- c) Requirements related to earthing have been updated in accordance with the latest provisions of IS 3043 and IS 732.

For the purpose of deciding whether a particular requirement of this standard is complied with, the final value, observed or calculated, expressing the results of a test, shall be rounded off in accordance with IS 2:2022 'Rules for rounding off numerical values (*second revision*)'. The number of significant places retained in the rounded off value should be the same as that of the specified value in this standard.

Indian Standard

**CODE OF PRACTICE FOR DESIGN, INSTALLATION AND MAINTENANCE OF
SERVICE LINES UP TO AND INCLUDING 650 V a.c.**

(First Revision)

1 SCOPE

This code covers the design, installation and maintenance of service lines and allied apparatus for both underground and overhead distribution systems of voltages up to and including 650 V a.c.

2 REFERENCES

The standards given in **Annex A** contain provisions, which through reference in this text, constitute provisions of this standard. At the time of publication, the editions indicated were valid. All standards are subject to revision, and parties to agreements based on this standard are encouraged to investigate the possibility of applying the most recent editions of the standards.

In the preparation of this standard, considerable assistance has also been derived from construction standards prepared by *Rural Electrification Corporation Ltd.*

3 TERMINOLOGY

For the purpose of this standard, the following definitions in addition to those already defined in Indian Standards on cables, shall apply.

3.1 Cable

A length of single insulated conductor (solid or stranded), or two or more such conductors, each provided with its own insulation, which are laid up together. The insulated conductor or conductors may- or may not be provided with an overall mechanical protective covering.

3.2 Cable, Armored

A cable provided with a wrapping of metal (usually in the form of a tape, strip or wire) providing a mechanical protection.

3.3 Cable, Metal-Sheathed

An insulated cable with a metal sheath to serve as mechanical protection and also as a return path for earth fault currents.

3.4 Cable, Polythene-Insulated

A cable in which the insulation of the conductor or conductors is a polythene compound.

3.5 Cable, PVC-Insulated

A cable in which the insulation of the conductors is a polyvinyl chloride compound.

3.6 Cable, PVC-Sheathed

A cable in which mechanical and chemical protection is provided for the core or cores by a sheath of a polyvinyl chloride compound.

3.7 Cable Bond

An electrical connection for the metallic armoring or metallic sheathing of a cable.

3.8 Cable Joint

The connection between two cables.

3.9 Chase

A hollow channel or duct provided in the building structure for accommodation of rising mains and other electrical services.

3.10 Circuit-Breaker

A device capable of making and breaking the circuit under all conditions, and unless specified otherwise so designed as to break the current automatically under abnormal conditions.

3.11 Cleat

An insulated incombustible or fire retardant support normally used for insulated cable.

3.12 Conductor, Aerial

Any conductor which is supported by insulators above the ground and is directly exposed to the weather

3.13 Conductor, Bare

A conductor not covered with insulating material.

3.14 Conductor, Insulated

A conductor adequately covered with insulated material of such quality and thickness as to prevent danger.

3.15 Connector

A mechanical grip shrouded in insulating material for connecting the conductor of a cable or of a flexible cord to that of another cable or of another flexible cord.

3.16 Cutout

Any appliance for automatically interrupting the transmission of energy through any conductor when the current rises above a predetermined amount and shall also include fusible cutout.

3.17 Cutout Board

A board of insulating material on which the cutouts are installed.

3.18 Distributing Board (Section Fuse Board)

An assembly of small bus-bars with or without disconnection links, switches, fuses, or the like, for connecting, controlling, or protecting a number of branch circuits fed from a main circuit.

3.19 Distributing Mains

The portion of any main with which a service line is, or is intended to be, immediately connected.

3.20 Distribution Pillars

A totally enclosed structure or pillar containing links or fuses for interconnecting distributors.

3.21 Dividing Box

A closed box in which the cores of multicore cable can be connected to external conductors.

3.22 Diversity Factor

The ratio of the sum of the maximum demands of several consumers or loads served by the service line to their maximum simultaneous demands.

3.23 Earth

To make an electric connection between a conductive part and a local earth.

3.24 Earth Electrode

Conductive part that is in electric contact with local earth, directly or through an intermediate conductive medium.

3.25 Earthed Conductor

Protective conductor from the earthed point of the source, which runs along with live conductors (eg. Protective conductor in a TN-S system)

3.26 Earthed Neutral Conductor

Combined Neutral and protective conductor (eg. PEN conductor in a TN-C-S system)

3.27 Earthed Terminal

A terminal which is solidly connected to the earthed conductor or earthed neutral conductor of an incoming service line. (eg. PEN conductor in a TN-C-S system or PE conductor in a TN-S system)

3.28 Earthing Conductor

Conductor forming a conductive path between a conductive part and an earth electrode.

3.29 Earthing Arrangement (Also Called as Earthing System)

All the electric connections and devices involved in the earthing of a system, an installation and equipment

3.30 Earth Cable Bond

A cable bond used for connecting the armouring or lead sheath of a cable or both to earth electrode.

3.31 Electric Line

Any line which is used for carrying electricity for any purpose and includes,

- a) any support for any such line, that is to say, any structure, tower, pole or other thing in, on by or from which any line is or may be, supported, carried or suspended, and
- b) any apparatus connected to such line for the purpose of carrying electricity.

3.32 Electric Supply Code

As specified under Section 50 of *Electricity Act*.

3.33 Guarded

Covered, shielded, fenced, or otherwise protected by means of suitable casings, barriers, rails or metal screens to remove the possibility of dangerous contact or approach by persons or objects to a point of danger.

3.34 High Rise Building

A building 15 m or above in height above average ground level surrounding the building. (irrespective of its occupancy)

3.35 Independent Earthing

An earthing arrangement may be considered electrically independent of another earthing arrangement if a rise of potential with respect to earth in one earthing arrangement does not cause an unacceptable rise of potential with respect to earth in the other earthing arrangement.

3.36 Licensee

A person who has been granted a licence under section 14 of *Electricity Act*;

3.37 Load Factor

The ratio, expressed as a numerical value or as a percentage, of the energy consumption within a specified period (year, month, day, etc) to the energy consumption that would result from continuous use of the maximum kW demand occurring within the same period.

NOTE — The load factor for a given demand is also equal to the ratio of the utilization time to time in hours within the same period.

3.38 Meter Cupboard

An enclosure having a locked door and inside which a licensee's energy meters, cutouts and such other apparatus are installed.

3.39 Neutral Conductor

Conductor electrically connected to the neutral point and capable of contributing to the distribution of electric energy.

3.40 Neutral Point

Common point of a star-connected polyphase system.

3.41 Nominal Voltage (of an Installation)

Voltage by which an installation or part of an installation is designated.

3.42 Overhead Line

Any electric supply line which is placed above ground and in open air but excluding live rails of a traction system.

3.43 Point of Commencement of Supply of Electricity

The point at the incoming terminal of the switchgear installed by the consumer.

3.44 Protective Earthing

Earthing for purposes of electrical safety. (e.g. connection of Protective earth terminal of a class 1 equipment to the protective equipotential bonding / MET of an installation).

3.45 Protective Earthing Conductor (PE conductor)

Protective conductor provided for protective earthing.

3.46 Rated Voltage (of Cable)

The voltage at which the cable is designed to operate. In case of three-phase ac system, the rated voltage means the voltage between phases.

3.47 Sealing Ends (Sealing Box or Sealing Chamber)

A close box fitted to one end of a cable for external connection, in such a manner as to protect the insulation of the cable from air or moisture.

3.48 Service line

Any electric supply line through which energy is, or is intended to be, supplied:

- a) To a single consumer either from a distributing main or immediately from the licensee's premises, or
- b) From a distributing main to a group of consumers on the same premises or on adjoining premises supplied from the same point of the distributing mains.

3.49 Service Position

The place where the service line terminates (*see also 8.3*).

3.50 System Earthing (Also Called as Electric System)

Functional earthing and protective earthing of an electric system consisting of a source, distribution and installations.

3.51 Straight Through Joint

A joint used for connecting two ends of conductors or cables in series.

3.52 Tee Joint

A joint used for connecting a branch conductor or cable to a main conductor or cable, where the latter continues beyond the branch.

3.53 Temporary Overvoltage (U_{TOV})

A fundamental frequency overvoltage occurring on the network at a given location, of relatively long duration.

NOTE — Temporary over voltages may be caused by faults inside the LV system or inside the HV system. Temporary over voltages, typically lasting up to several seconds, usually originate from switching operations or faults (for example, sudden load rejection, single-phase faults, etc.) and/or from non-linearity (ferro resonance effects, harmonics, etc).

3.54 Trough

A channel in which cables are laid to protect them against external mechanical damage.

3.55 Underground Line

An electric line laid in the ground.

3.56 Way Leave

Permission obtained from local authorities, government departments, port trusts, railway authorities or owners to facilitate laying and placing of electric supply mains or both through their property.

3.57 Mains

Any electric supply line through which energy is, or is intended to be, supplied by a licensee / franchisee to the consumers.

4 GENERAL REQUIREMENTS

4.1 Conformity with The Electricity Act, 2003 — The work of installation of the service line shall be carried out in conformity with the requirements of *The Electricity Act, 2003* and the rules and regulations made under the powers conferred to appropriate government, Commission, Authority which include;

- a) *Central Electricity Authority (Measures relating to Safety and Electric Supply) Regulations, 2023*, framed thereunder with special attention to *Regulations 16, 17, 18, 19, 20, 21 43, 44 and 74.*
- b) *Electricity Regulatory Commission, Supply Code and Conditions of Supply*

5 EXCHANGE OF INFORMATION

5.1 Exchange of information is necessary between the licensee and the applicant for electric supply, owners of the properties and local authorities through or over which the service line is intended to pass. The engineer of the licensee and architect or builder, in early consultation, should decide upon the route of the service cable, location of service position, meter cabin/room and details of ducts or other accommodation required for running the cable from the entry position at the boundary of the premises to the location of service position. The provisions in the plans shall be in mutual agreement with the person involved in design and construction of electrical installation in the building.

5.1.1 Applicant — The applicant for electric supply shall fill in the requisition form as required under Supply Code and Conditions of Supply made applicable by the Licensee.

5.1.2 The applicant shall submit to the licensee, whenever called for, complete set of drawing of buildings and site plans to enable licensees to decide upon the route position of the service mains.

5.1.3 The Licensed Electrical Contractor shall assess load requirement based on the requirements given by the owner / applicant with due consideration for future requirements. The minimum load requirement shall be either assessed load or the minimum consideration of load in W/m^2 as decided by the licensee, whichever is higher.

5.1.4 The Licensed Electrical Contractor shall assess total load requirement for the project along with common services by working out anticipated maximum demand with due consideration for load diversity. This information shall be shared with the licensee.

5.1.5 For release of service connection, the Licensed Electrical Contractor shall verify and test the installation as per the format given under **Annex QQ, RR, TT** of IS 732 and shall submit the test report of the installation to the licensee.

5.1.6 The Licensed Electrical Contractor shall provide copies all documents exchanged between licensee and himself related to application, test report, sanction load and release of supply.

6 MATERIALS AND EARTHING

6.1 All materials used in the installation of service line shall be of sufficient rating for power, insulation, estimated fault current, and of sufficient mechanical strength for the work for the duty cycle they may be required to perform under environmental condition and shall be constructed installed, protected, worked, and maintained in such a manner to ensure safety. Furthermore, materials shall conform to the relevant Indian Standards wherever these exist.

6.2 Earthed terminal shall be provided for each consumer at the point of supply.

6.3 Neutral of the service cable shall be earthed at consumers premises as a part of protective multiple earthing to be provided by the licensee.

6.4 The Earthed Terminal and Earthed Neutral, the mandatory regulatory requirements obligatory to the supplier shall be of sufficient size in order to carry out protective equipotential bonding at the consumer premises. Provisions for connecting at least 5 protective conductors equal to the size of incoming service conductor shall be provided.

6.5 Earth electrodes connected to the earthed terminal at the consumer premise as per regulation 18 for voltage higher than 250 volt, shall conform to IS 3043 / IS732. The following can be considered as earth electrode;

6.5.1 Concrete embedded foundation earth electrode or Soil embedded foundation earth electrode. (*See* Fig. 92 of IS 732 or Fig A-1 of SP-30 (Part 1/Sec 18)).

6.5.2 Type A or Type B earth electrode of a lightning protection system as per IS/IEC 62305-3.

6.5.3 For buildings without a lightning protection system, a pipe or solid rod having length not less than 1 meter hammered in soil.

6.5.4 Any other earth electrodes as specified in Table 13 of IS 732 or Table B1 of SP-30 (Part 1/ Sec 18).

6.6 Earth enhancing compounds may be used only in locations where the soil resistivity is higher than 3000 Ω m.

NOTES

1. Direct connection from earthed terminal to the down conductor of lightning protection system is a recommended practice.
2. A specific low value of earth electrode resistance is not necessary.
3. Earth enhancing compounds have the tendency to accelerate the corrosion in locations where the soil

resistivity is lesser than $< 200 \Omega\text{m}$.

7 SERVICE POSITION

7.1 Service lines shall be terminated into adequately ventilated and lighted positions enclosed with masonry, metal or fire-retardant polyester/polycarbonate enclosure not easily accessible to unauthorized persons but accessible at all reasonable times to the licensee's representatives.

7.2 The service lines shall not be terminated near furnaces and hearths, or such other places where gases, fire hazards and other fumes exist. As far as possible the service position should not be located near or below staircases, washing places, lavatory blocks, near drainage, water and gas pipes, etc.

7.3 The service lines should not be terminated in positions where heavy materials are stacked, shifted or moved. Ample space shall be available in front for the workman to work safely on the line. Wherever medium pressure exists this space shall not be less than one meter.

8 THE CABIN/ROOM, BOX OR ENCLOSURE

8.1 The cabin/room, box or enclosure shall afford adequate protection to the licensee's apparatus from dust, vermin and weather.

8.2 The size of the service cabin, box or enclosure should be sufficient to accommodate the licensee's equipment and the meters for all the consumers, including the prospective consumers, if any.

8.3 Sufficient space for installing the main switches, including fire switch and termination of consumer's wiring should be available adjacent to the service position.

8.4 For Cabin/room there shall be adequate ventilation.

8.5 Location of Cabin/room, box or enclosure shall be safe from water seepage, leakage, storm water.

8.6 Authorised person of the supplier shall have an easy access to such place.

8.7 In case of multistoried buildings where distribution to upper floors is done with bus trunking system, there shall be consideration for installation of meters and allied equipment on each floor.

9 ROUTE OF CABLE

While deciding the route of the service cable, the following aspects should be considered.

9.1 The route should be, as far as possible, the shortest distance from the nearest licensee's distributing mains to the proposed service position.

9.2 Underground obstructions, such as services of other utilities, drainage, pipes and manholes, should be avoided.

9.3 The route and method of construction of the cable should be such that carrying out repairs and maintenance thereto shall be easy.

9.4 Where the route of the cable is to be reinstated by paved surface, the feasibility of laying ducts or pipes and provision of manholes is to be considered, for laying the service cable to avoid future

excavation of the paved surface for maintenance.

9.5 The route of the service lines shall provide ample space for bending cables within safe limits wherever necessary.

9.6 If the route of the cable is to pass through the-basement, the feasibility of inserting lead-in tubes through the walls and cleating of cables to the walls or ceilings is to be considered.

9.7 Where the route of the cable is such, that the cable is required to be cleated to the walls or ceiling, it should be clear of locations where heavy materials are likely to be stored or moved.

9.8 The route of the cable shall be away from furnaces and hearths and such other locations where gases and fumes exist. It should also be clear from drainage, water or gas pipes, etc.

10 SELECTION OF SIZE OF CABLE

10.1 The choice of the size of the cable shall ensure that voltage variation to the consumer remains within the permissible limits stipulated in the Central Electricity Authority (Measures relating to Safety and Electric Supply) Regulations, 2023. This would depend on the diversity of load, current carrying capacity, future extensions contemplated, type of installations and site conditions. The current carrying capacity of the cable is influenced by type of material and construction used for the conductor and insulations and their short-circuit levels. *See IS 3961 (various parts) for more information.*

10.2 The sizes of the cables for service, lines shall be chosen in accordance with IS 694. For deciding current carrying capacity, reference shall be made to IS 3961 (various parts).

11 METHOD OF EXCAVATION AND LAYING OF SERVICE CABLE

11.1 The method of excavation and laying of service cable shall be in accordance with IS 1255.

12 LEAD-IN TUBE

12.1 Where the service cable is to be laid, the entry to the building through the wall shall be through a lead-in tube fixed in the wall.

12.2 The size of the lead-in tube shall be so chosen as to permit easy drawal of cables selected for the service lines and generally consist of GI or RCC pipe of 75 to 100 mm diameter embedded and firmly grouted in the wall.

12.3 The point of entry of the cable through the lead-in tube should be properly sealed to prevent the ingress of water and entry of vermin, etc.

13 SUPPORTING THE CABLE

13.1 Suitable supports (clips, clamps, etc.) should be provided at regular intervals which should not be less than one meter or more than two meters, depending upon the size and weight of the cable. The supports should be fixed either to the walls or to the ceiling, as required.

14 SERVICE CABLES TO MULTI-STORIED BUILDINGS

14.1 Liaison between the architect, owner, builder, electrical contractor and the licensees is essential for deciding upon the number, size and location of the electric supply services and to decide whether all services are to be terminated on the ground floor or on upper floors. There should be consultations between these persons during the planning stage of the work in order to decide upon the following:

- a) Point of entry of licensee's service cables;
- b) Route of rising and lateral conductors;
- c) Provisions to be made during the course of the building works for the adequate accommodation of ducts, fuse gears and metering arrangements on the premises.

In multi-storied buildings readily accessible vertical ducts or chases of adequate capacity should be provided in the building structure for the accommodation of the rising service cables/rising mains/bus trunking.

14.2 In general, vertical ducts or chases should not be less than 450 mm wide and 150 mm deep in construction, but in large buildings where a number of rising service cables/main are to be installed the vertical duct or chase may be as much wide as necessary. Fire barriers should be provided to comply with the firefighting requirements.

14.3 The design of the vertical duct or chase should permit easy installation and replacement of the cables/mains.

14.4 At the upper end of the vertical duct maybe provided, if required, with a hook of adequate size for pulley arrangement for pulling the service cable up to the topmost floor so as to provide for easy installation and quick replacement of faulty cable.

14.5 Only non-draining type of cables should be used for service to the upper floors.

14.6 Adequate precautions should be taken to prevent the entry of water or dust into the duct.

14.7 The following requirements from *Regulation 38 of Central Electricity Authority (Measures relating to Safety and Electric Supply) Regulations, 2023* shall be considered.

14.7.1 *Regulation 38 (3) multistoried buildings* means: multistoried buildings of more than fifteen metre height and other premises such as airports, hospitals, hotels, places of entertainment, places of worship, cultural centers, stadium, academic buildings, test labs, industrial installations, installation with explosive or flammable material, railway or metro stations and other public buildings, namely

- a) The supplier or owner of the installation shall provide at the point of commencement of supply a suitable isolating device with cut-out or breaker to operate on all phases except neutral in the three-phase, four-wire circuit and fixed in a conspicuous position at not more than 1.70 metre above the ground so as to completely isolate the supply to the building in case of emergency;
- b) No other service pipes and cables shall be taken through the ducts provided for laying of power cables and all ducts provided for power cables and other services shall be provided with fire barrier at each floor crossing;
- c) The Fire Retardant Low Smoke and Low Halogen power cables shall be used in building of

more than fifteen metre height as per relevant standards:

- d) Provided that Halogen Free Flame Retardant power cables as per the relevant standards shall be used in airports, hospitals and hotels irrespective of height;
- e) Distribution of electricity to the floors shall be done using bus bar trunking system;

15 CONNECTION OF SERVICE CABLE TO THE DISTRIBUTING

15.1 The service cable(s) may be connected to the distributing mains, either overhead or underground by any of the following methods:

- a) By teeing it to the underground distributing cable,
- b) By tapping from the overhead distribution line,
- c) By connecting it to a low voltage distribution board of a substation situated either on the premises or outside,
- d) By connecting it to a distribution pillar, and

By looping it through termination point of another service.

16 METHOD OF TERMINATION

16.1 Paper insulated lead sheathed cables shall be terminated in a suitable terminal box in accordance with details given in IS 1255.

16.2 In case of PVC cables, a gland made of brass, mild steel or aluminum of suitable size may be used for the termination of the service cables. Typical arrangements are shown in Fig. 1 and Fig. 2.

17 CONNECTION OF SERVICE LINE TO THE CUTOUT AT THE TERMINATION POINT AT CONSUMER'S END

17.1 The cores of the service cable shall be connected to suitable size of cutouts installed inside the enclosure (*see* Fig. 3).

17.2 The other end of the cutout should be connected to the meter in case of one meter (*see* Fig. 3) or to the other meter cutouts in case of more than one meter through suitable means such as bus-bars (*see* Fig. 4). Such bus-bars, when provided, shall be adequately and properly covered and the live metal parts suitably made inaccessible.

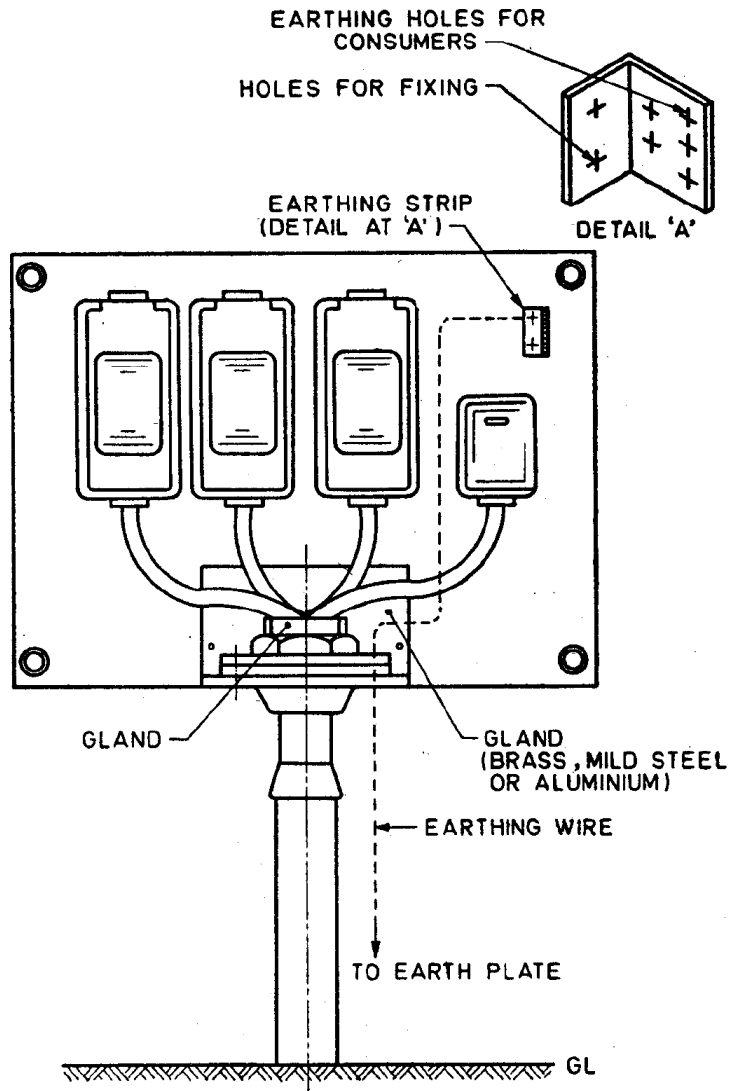
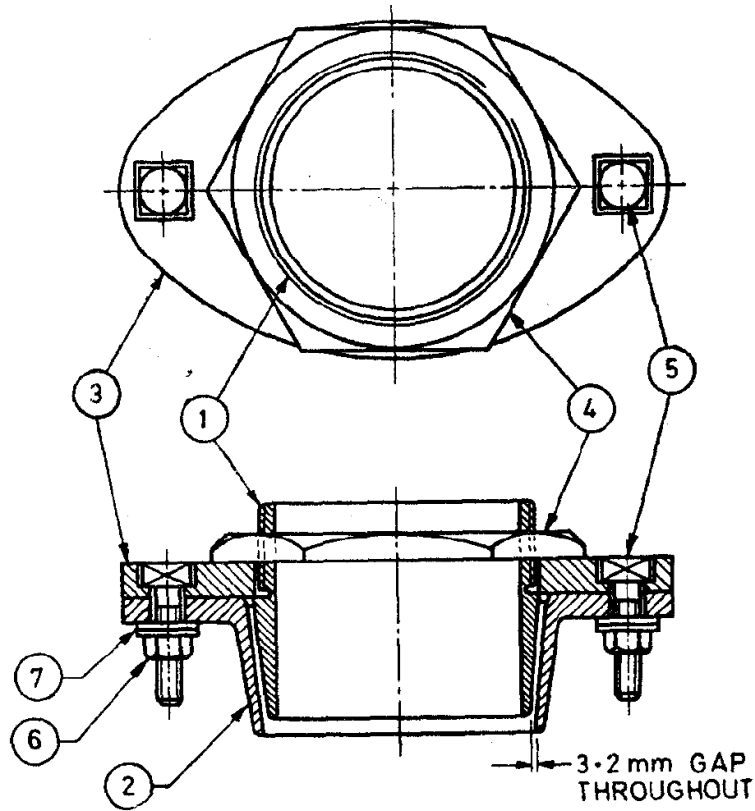
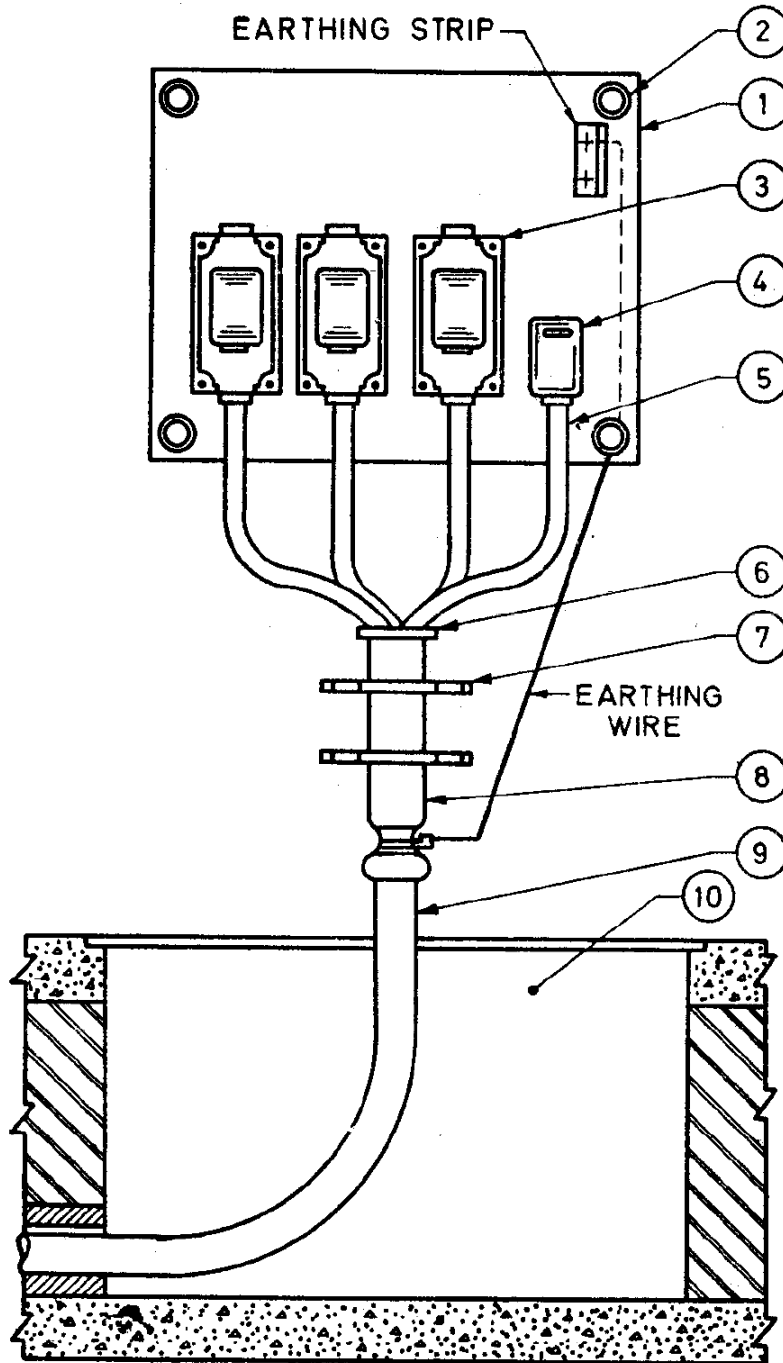

FIG. 1 TYPICAL ARRANGEMENT FOR TERMINATION FOR
4 CORE PVC SERVICE CABLE



<i>Part No.</i>	<i>Description</i>	<i>Number</i>
1	Inner cup	1
2	Outer cup	1
3	Flange	1
4	Check nut	1
5	Square head screw	2
6	Hexagonal nut	2
7	Plain washers	4

FIG. 2 TYPICAL SKETCH SHOWING CABLE TERMINATING GLAND



Part No.	Description	Part No.	Description
1	Cutout board	6	Teak-wood bush, impregnated
2	Board insulator	7	Clamp for sealing end
3	Cutout	8	Sealing end
4	Neutral connector	9	Cable
5	Leads	10	Manhole

FIG. 3 TYPICAL CONNECTION OF SERVICE CABLE AT THE TERMINATION POINT

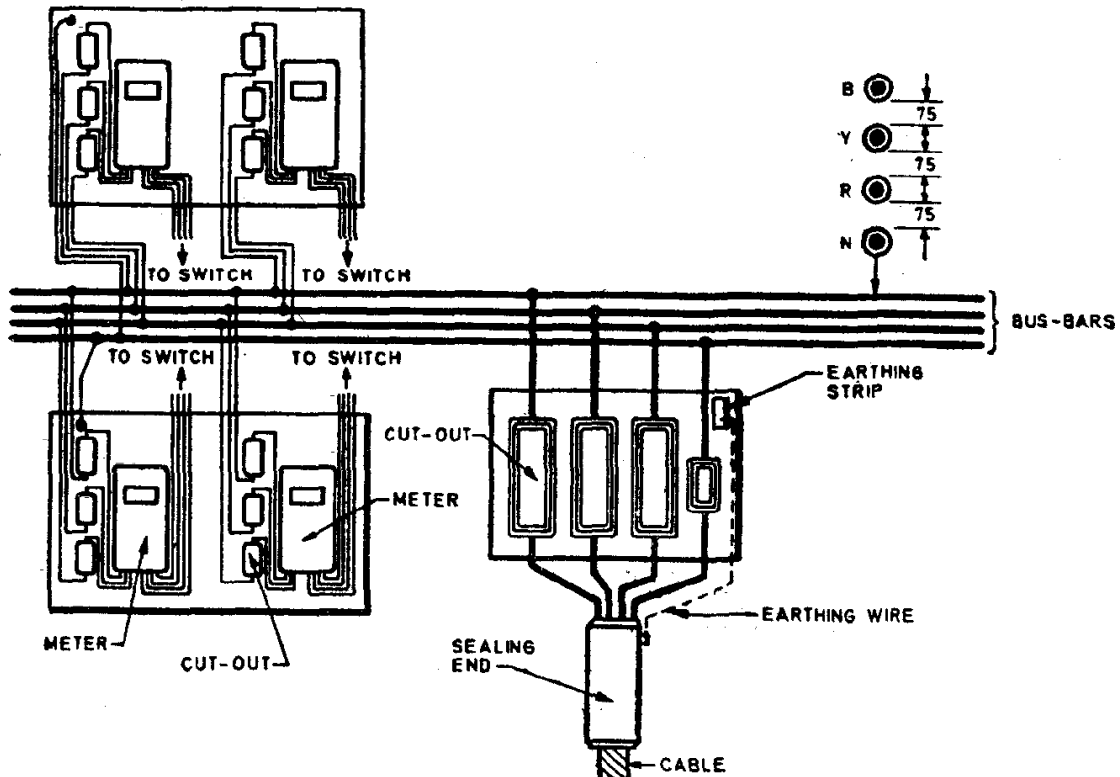

All dimensions in millimetres.

FIG. 4 TYPICAL ARRANGEMENT OF BUS-BAR OVER SERVICE POSITION

18 OVERHEAD LINES

18.1 No service connection shall be taken off an overhead line except at a point of support.

18.2 The service line shall be installed and guarding provided in accordance with the provisions of IS 5613 series.

18.3 In case of overhead distribution, the following methods shall be adopted for installing overhead services:

- Bare Conductor;
- Insulated Conductors; and
- Unarmored Cable.

18.3.1 Bare Conductor

18.3.1.1 Vertical entry —The bare conductors shall be fixed to the cross arm mounted on galvanized iron pipe of minimum diameter of 50 mm. The bare conductors shall be kept at a height of 4.5 m from the top of the structure except where they are adequately guarded in which case the vertical clearance may be 2.7 m. The GI pipe shall be provided with double bends at the top. The pipe shall be secured by at least 2 clamps made of 50×6 mm mild steel flats and fixed firmly to the wall. It shall, in addition, be provided with a guy. Service connection shall be given with weather-proof or PVC-insulated cable through this GI pipe. Well-fitting wooden or PVC bushes shall be provided at both ends of this GI pipe.

18.3.1.2 Horizontal entry — The bare conductors shall be fixed to a bracket in the form of channel (\sqcap) made of angle iron of size not less than $50 \times 50 \times 6$ mm with insulator. The bare conductors shall be kept 1.8 m away from the edge of the structure. The ends of the bracket shall be cut and split and embedded in the wall with cement mortar. The service connection shall be given with weather-proof or PVC-insulated cable through suitable size GI pipe fixed to the wall. The GI pipe shall be bell mouthed and bent downwards near the service entry. Well-fitting wooden or PVC bushes shall be provided at both ends of the GI pipe.

18.3.2 *Insulated Conductors*

Service connection shall be given by weatherproof or PVC-insulated cable on GI bearer wire. The GI bearer wire shall be of minimum 3.15 mm size. One end of the GI bearer wire shall be attached to a clamp which is fastened to the nearest pole carrying distribution lines from where the service connection is intended to be given. The other end of the GI bearer wire shall be fastened to 20 mm dia GI pipe for a clearance up to 4.5 m which is fixed to the wall with guy, etc. The GI pipe shall be fixed to an angle iron of size $40 \times 40 \times 6$ mm with suitable guy for high supports and for a clearance exceeding 4.5 m. Alternatively, when the height of the structure permits minimum ground clearance, the other end of this GI bearer wire may be fixed to a hook, I-bolt or bracket embedded with cement mortar in the wall. The weather-proof or PVC-insulated cable shall pass through GI pipe of minimum diameter of 20 mm, which is bell mouthed and bent downwards. Well-fitting wooden or PVC bushes shall be provided at both ends of the GI pipe. Fig. 5 illustrates one typical example of overhead insulated wire service line.

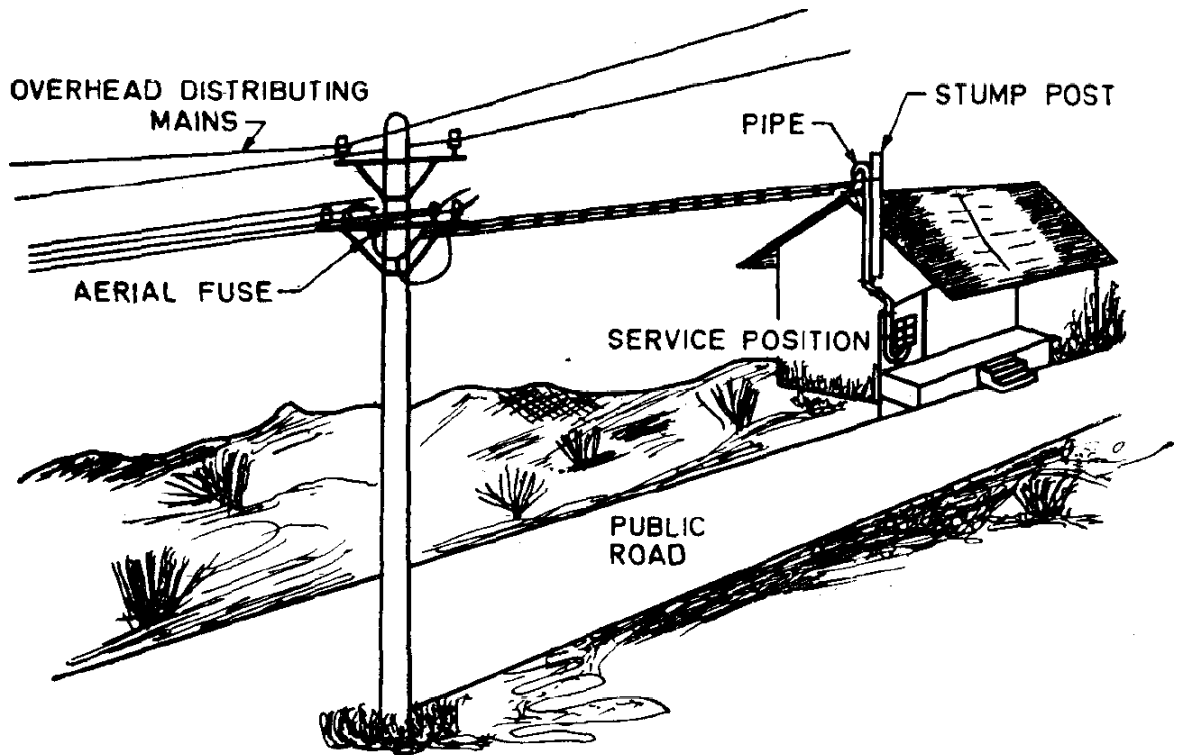

FIG. 5 TYPICAL OVERHEAD INSULATED WIRE SERVICE LINE

18.3.3 Unarmoured Cable

PVC-insulated and PVC-sheathed unarmoured underground cable may be used in place of weather-proof or PVC insulated cable for giving service connection on GI bearer wire.

18.4 The service line should be installed and guarding provided in accordance with the provisions of IS 5613 series.

18.5 The run of the service line shall be such as to be normally out of reach of persons in the premises even when leaning out of windows. The heights and clearances of the service line shall be in accordance with the provisions of the *Regulation 62 of the Central Electricity Authority (Measures relating to Safety and Electric Supply) Regulations, 2023*.

19 JOINTING OF OVERHEAD SERVICES TO THE DISTRIBUTION LINES

19.1 In case of copper to aluminum joints, it is recommended that a bimetallic clamp should be used and in case of aluminum to aluminum joints, anti-corrosive grease should be applied to the conductors before mechanically fixing the clamp.

19.2 Tee off the service line should be done only on a pole and not between any span.

19.3 The phase conductors of the service line should be connected to the distributing mains through
a) an aerial fuse or

- b) preferably fuses installed on the poles.

The service line is tapped from these fuses.

19.4 While taking overhead service line through insulated conductor to a consumer, spare lengths of cable should be left as loops at both the ends, that is, at the connection with the mains as well as at the consumer end.

20 EARTHING AND SAFETY

20.1 The following regulations and related subjects shall be considered for statutory requirements of earthing by the owner of the service line.

20.1.1 *Regulations 17, 18, 43(i) and 74 of Central Electricity Authority (Measures relating to Safety and Electric Supply) Regulations, 2023.*

20.1.2 *Regulations 99, 100 and 101 of Central Electricity Authority (Technical Standards for Construction of Electrical Plants and Electric Lines) Regulations, 2010.*

20.1.3 A suitable earthed terminal shall be provided at the service position in accordance with Rule 18 of the *Central Electricity Authority (Measures relating to Safety and Electric Supply) Regulations, 2023.*

20.2 System Earthing: The system earthing are classified as TN System, TT System and IT System. They are explained below:

20.2.1 TN System - has one or more points of the source of energy directly earthed, and the exposed and extraneous conductive parts of the installation are connected by means of protective conductors to the earthed point(s) of the source, that is, there is a metallic path for earth fault currents to flow from the installation to the earthed point(s) of the source. TN systems are further sub-divided into TN-C, TN-S and TN-C-S systems.

- a) *TN-C System* - The neutral and protective functions are combined in a single conductor throughout the system
- b) *TN-S System* - Systems where there are separate neutral and protective conductors throughout the system.

NOTE — The protective conductor in a TN-S system may also be earthed anywhere in the system, including independent earth electrode within the consumer's premise. For overhead services, the protective conductor is additionally earthed at the distribution at every 3rd pole for lines below 650 volts as per *Regulation 74 of Central Electricity Authority (Measures relating to Safety and Electric Supply) Regulations, 2023.*

- c) *TN-C-S System* - The neutral and protective functions are combined in a single conductor but only in part of the system.

NOTE — TN-C-S with PME is a system, where PEN conductor is additionally earthed at the distribution at every 3rd pole for lines below 650 volts as per *Regulation 74 of Central Electricity Authority (Measures relating to Safety and Electric Supply) Regulations, 2023* for overhead services.

20.2.2 TT System - has one or more points of the source of energy directly earthed and the exposed and extraneous conductive parts of the installation are connected to a local earth electrode or electrodes that are electrically independent of the source earth(s).

NOTE — In a TT system earth fault loop impedance will be higher resulting in reduction of fault current and non-disconnection of OCPD (such as fuses and MCB's) during an earth fault. Hence RCD's shall be installed at origin of installation as per *Regulation 44 of Central Electricity Authority (Measures relating to Safety and Electric Supply) Regulations, 2023* as a measure against earth fault. In a TT system, an earth terminal connected to an earth electrode at the service connection shall not be treated as an earthed terminal.

20.2.3 IT System — has the source either unearthed or earthed through a high impedance and the exposed conductive parts of the installation are connected to electrically independent earth electrodes. IT systems are not used for public electricity supply.

20.3 Service line as TN-S system with separate continuous earth wire.

20.3.1 The earth terminal should be connected by means of a protective conductor of a suitable size to the metal sheathing of the service cable in case of armored cables if it is of adequate capacity for this purpose. In case of PVC-unarmoured cable, an earth continuity conductor should be provided for this purpose.

20.3.2 Overhead Services - In case of insulated conductor service line, the GI bearer wire (messenger wire) is bonded to the continuous earth wire of the overhead distributing system. At the consumer's end the GI bearer wire (messenger wire) is connected to the earth terminal at the service position.

20.3.3 In case of bare conductor service line, a separate continuous earth wire will run along with the phase and neutral conductors in the overhead distributing system and is connected to the earth terminal at the service position.

20.3.4 The metallic casing of the service cutouts shall be connected to the earth terminal at service position. This earth terminal also called as earthed terminal shall be provided and maintained by the owner of service line on the consumer's premises for the consumer's use. Protective equipotential bonding at consumer premise shall be bonded to this earth terminal.

NOTE — The earth terminal can be considered as an earthed terminal only if the metallic earth fault return path to the neutral of the source is ensured by the owner of the service line.

20.4 Service line as TN-C-S system with PME using earthed neutral conductor.

20.4.1 Clause 4 of IS 3043: Where the neutral and protective conductors of electricity supply system of Electrical supply undertaking are combined, it is called as TN-C-S system. The PEN conductor, which is referred to as a combined neutral and earth (PEN) conductor, is earthed at the source and extremities of the distribution mains and point in between. Multiple earthing of the

PEN conductor ensures that if the PEN conductor becomes open circuit for any reason (probably cut or snapped), exposed-conductive parts remain connected to earth. Under such conditions the supply voltage between the installation line and neutral conductor is substantially reduced.

20.4.2 The earth terminal at consumer premise should be connected by means of a link for testing purpose to the PEN conductor of the incoming supply system and to the conductor of a suitable size to the metal sheathing of the service cable in case of armoured cables.

20.4.3 In case of overhead insulated conductor service line, earth terminal at consumer premise should be connected by means of a link for testing purpose to the PEN conductor of the incoming supply system. In addition, the GI bearer wire (messenger wire) is bonded to the PEN conductor of the overhead distributing system and to the earth terminal at the service position.

20.4.4 In case of bare conductor service line, earth terminal at consumer premise should be connected by means of a link for testing purpose to the PEN conductor of the incoming supply system.

20.4.5 The metallic casing of the service cutouts shall be connected to the earth terminal at service position. This earth terminal also called as earthed terminal shall be provided and maintained by the owner of service line on the consumer's premises for the consumer's use. Protective equipotential bonding at consumer premise shall be bonded to this earth terminal.

NOTE — The earth terminal can be considered as an earthed terminal only if the metallic earth fault return path to the neutral of the source is ensured by the owner of the service line.

20.4.6 The PEN conductor shall be connected to the terminal or bar intended for the protective conductors as shown in **Fig 11, Fig 12 and Fig 13**.

20.5 TN-S type of system earthing is recommended for supply to apartments of commercial buildings where multiple consumers are present in one building and the service transformer is close to the building.

20.6 In all the cases, the earth fault loop impedance shall be tested to ensure the automatic disconnection of the supply in case of an earth fault. Record of every earth test made, and the result thereof shall be kept by the supplier for a period of not less than two years after the day of testing and shall be available to the Electrical Inspector when required.

20.7 In all the cases, the earth fault loop impedance has to be low enough to allow adequate earth fault current flow to cause an overcurrent protective device (for example, a fuse or circuit breaker) in the faulty circuit to operate in a sufficiently short time.

20.8 Where it is not possible to achieve a low enough earth fault loop impedance, disconnection may be initiated by fitting a residual current device (RCD) of disconnection current not higher than 30 mA.

20.9 In all the cases the Temporary Over Voltage (U_{TOV}) at consumer premise due to an earth fault at distribution or at the HV side of the supply transformer shall be kept below $1200 + \text{nominal}$

voltage up to 5 second or below 250 volt + nominal voltage, if the fault duration is higher than 5 seconds. For further information *see Annex B*.

20.9.1 In TN systems touch voltages at consumer premise during fault at HV side of the transformer shall be limited by implementing protective equipotential bonding at the consumer premise.

20.9.2 In TT system where the HV and LV earthing of the transformer are interconnected, the total resistance of the earth electrode shall be maintained to a minimum level so that the TOV between Live conductors and Earth are not exceeding the limit specified.

20.9.3 In TT system where the HV and LV earthing of the transformer are electrically independent, sufficient distance shall be maintained between the HV side earth electrode and LV side earth electrode. The minimum distance between the earth electrodes shall be 10 meters.

20.10 The supplier shall provide TN system for all consumers where Solar PV or any other grid connected power generation systems are used.

20.10.1 If TT system is provided by the supplier to such consumer premises, safety from earth fault protection shall be achieved by installing an RCD with a disconnection current not higher than 500 mA for additional protection from electric shock, Type A RCD with a disconnection current not higher than 30 mA shall be used in all premises. Locations where grid connected solar PV is installed with out simple seperation, Type B RCD with a disconnection current not higher than 30 mA shall be used as an additional protection against electric shock.

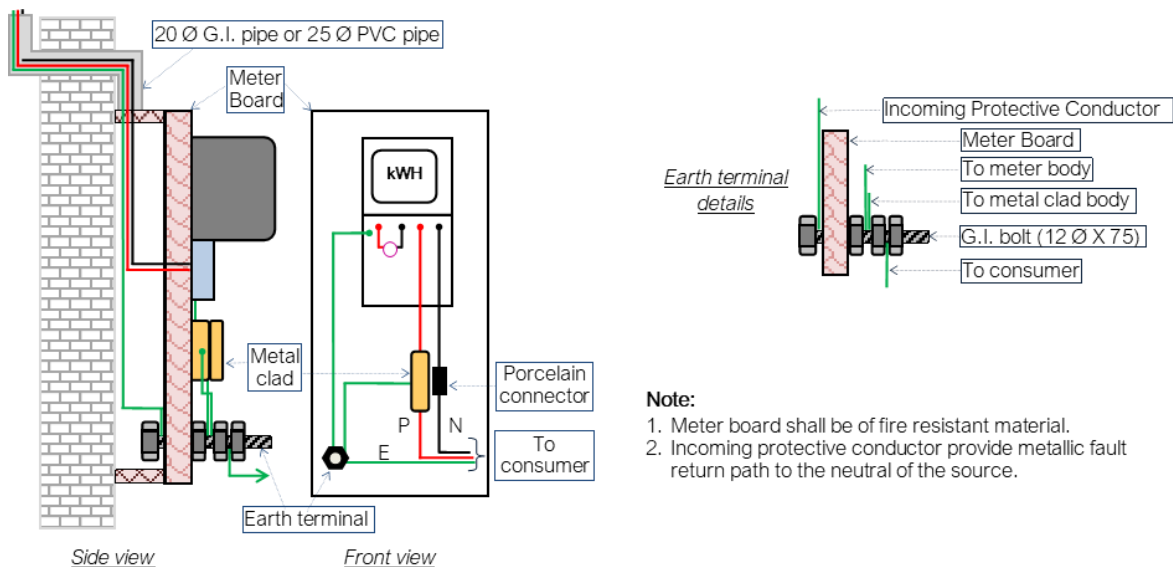

Fig. 6 Typical Connection Diagram of a Single-Phase Service Connection in a TN-S Network with Metal Clad Fuse Unit.

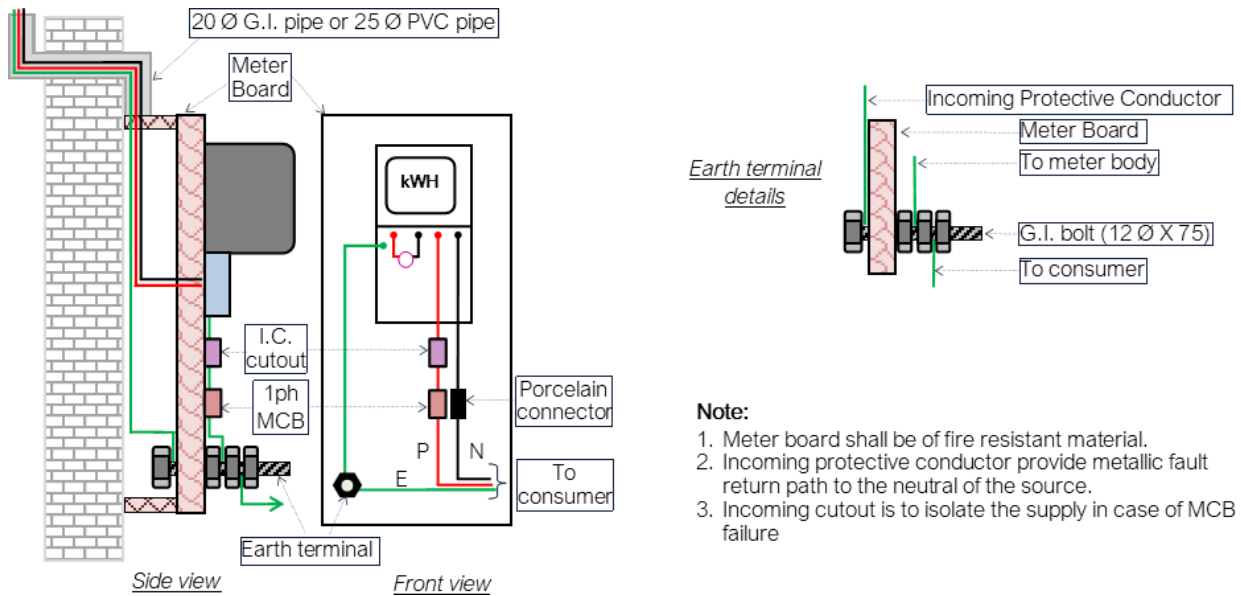

Fig. 7 Typical connection diagram of a single-phase service connection in a TN-S network with MCB.

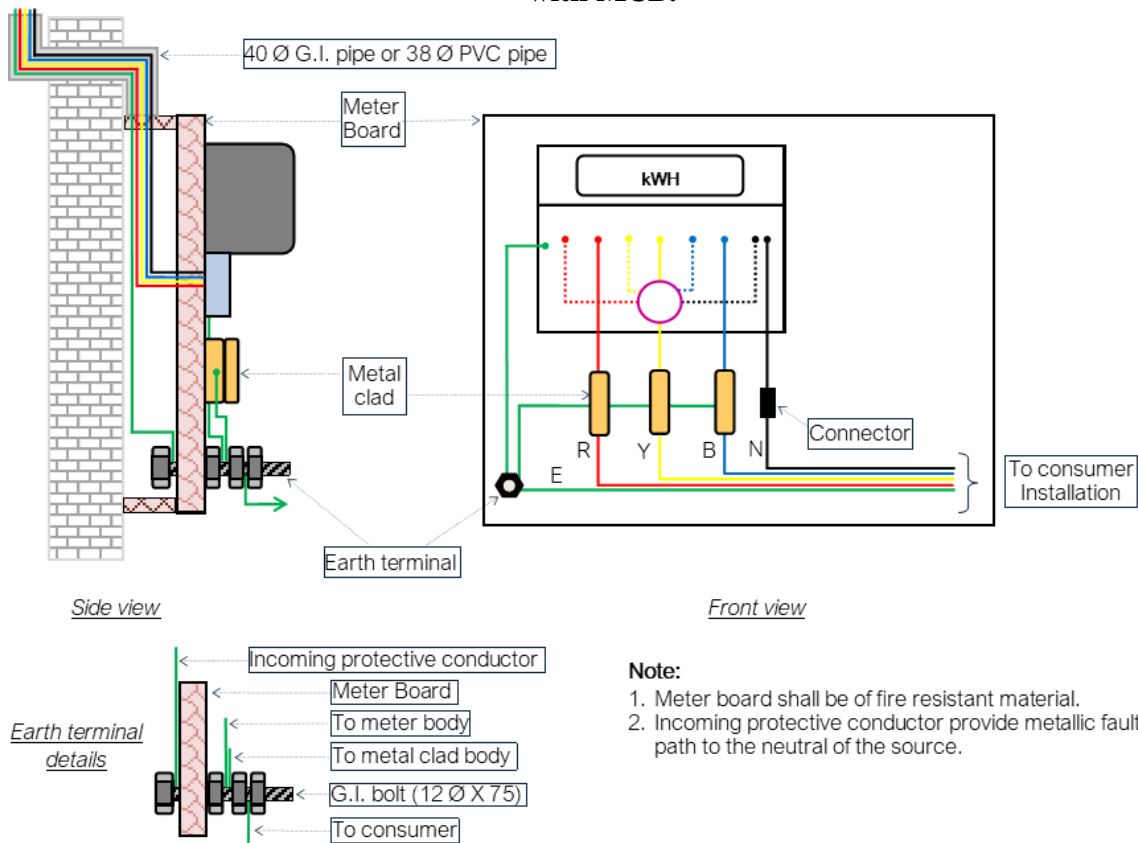

Fig. 8 Typical Connection Diagram of a Three-Phase Service Connection in a TN-S Network with Metal Clad Fuse.

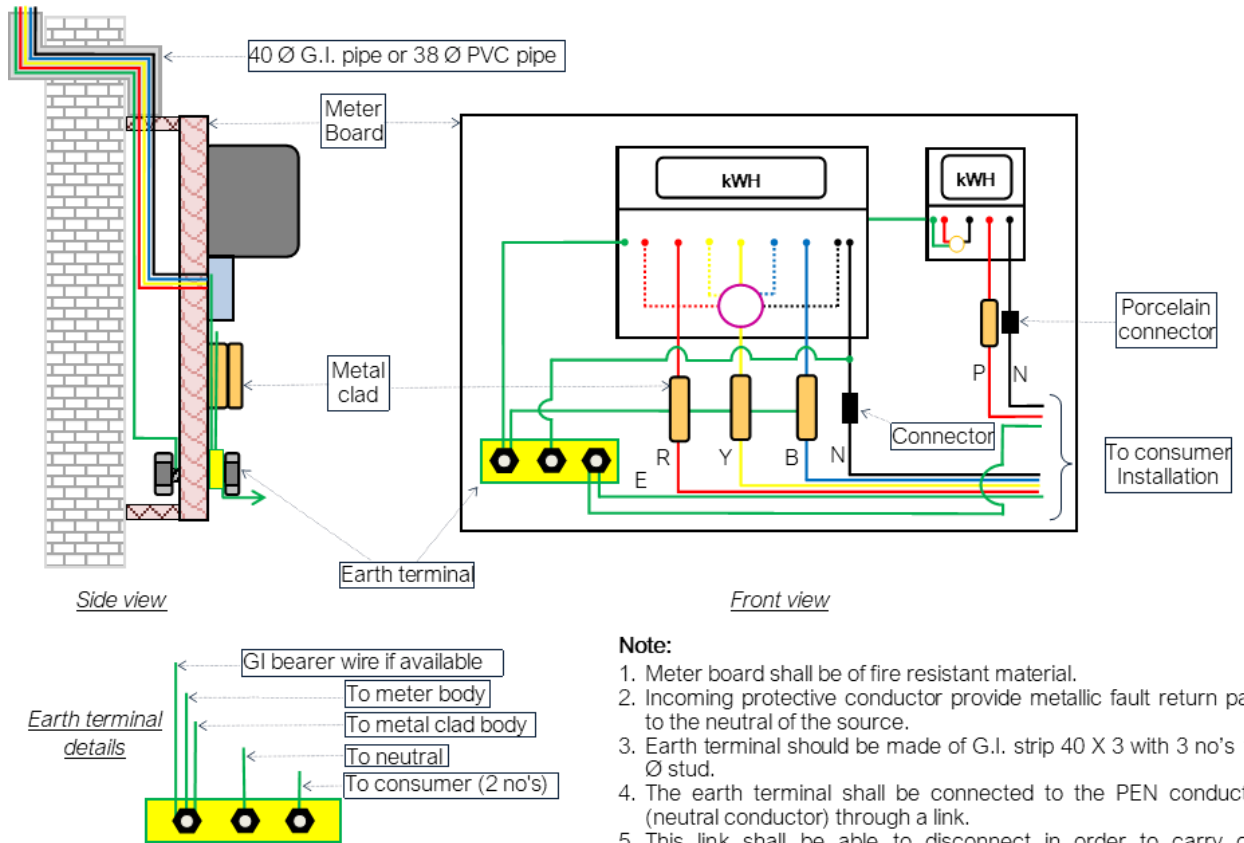
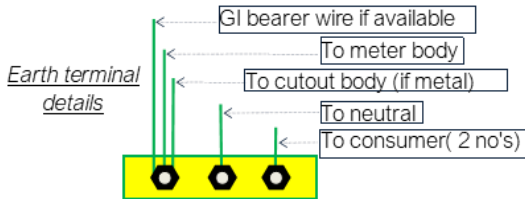
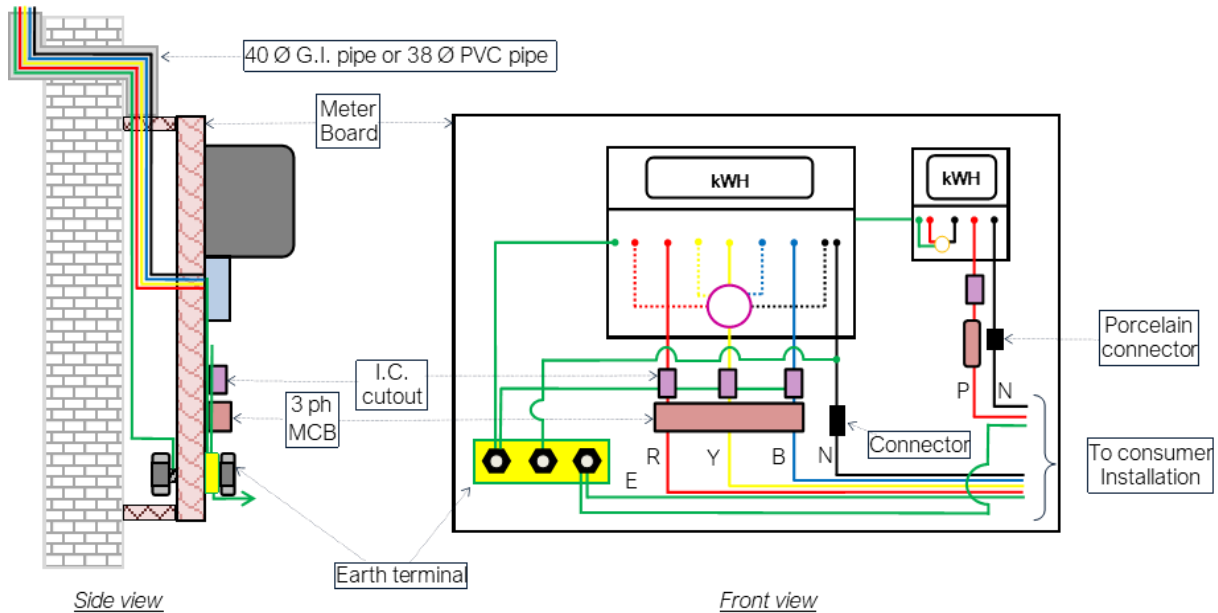

Fig. 9 Typical Connection Diagram of a Three-Phase and Single-Phase Service Connection in a TN- C-S Network With Metal Clad Fuse.



Note:

1. Meter board shall be of fire resistant material.
2. Incoming protective conductor provide metallic fault return path to the neutral of the source.
3. Earth terminal should be made of G.I. strip 40 X 3 with 3 no's 12 Ø stud.
4. The earth terminal shall be connected to the Incoming PEN conductor (neutral conductor) through a link.
5. This link shall be able to disconnect in order to carry out insulation resistance test.

Fig. 10 Typical Connection Diagram of a Three-Phase and Single-Phase Service Connection in a TN- C-S Network with MCB.

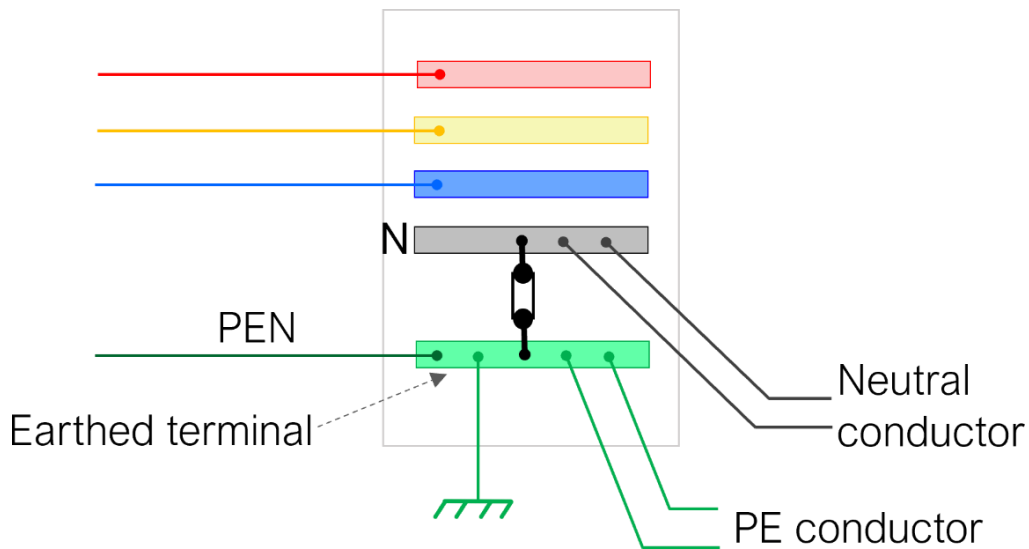

Fig. 11 Typical Connection Diagram of a PEN Conductor in a TN-C-S Network and Separation of PE Conductor Through a Link (Case 1).

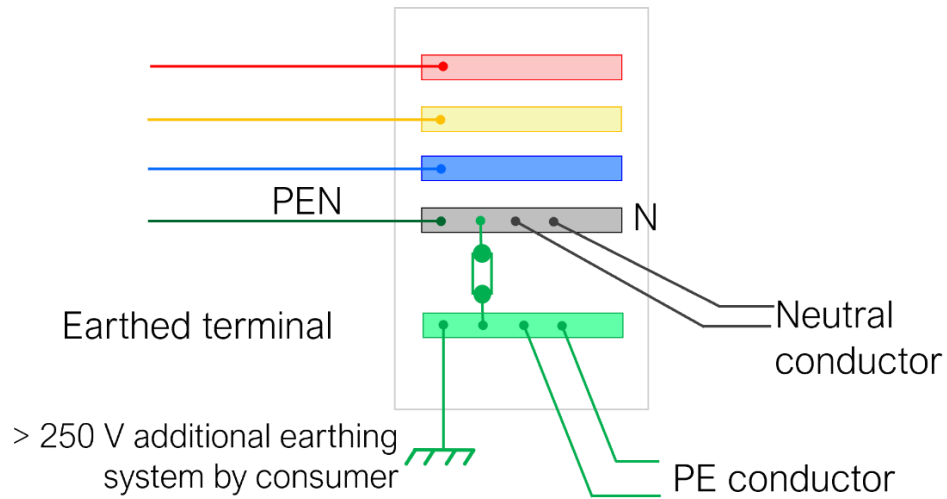

Fig. 12 Typical Connection Diagram of a PEN Conductor in a TN-C-S Network and Separation of PE Conductor Through A Link (Case 2).

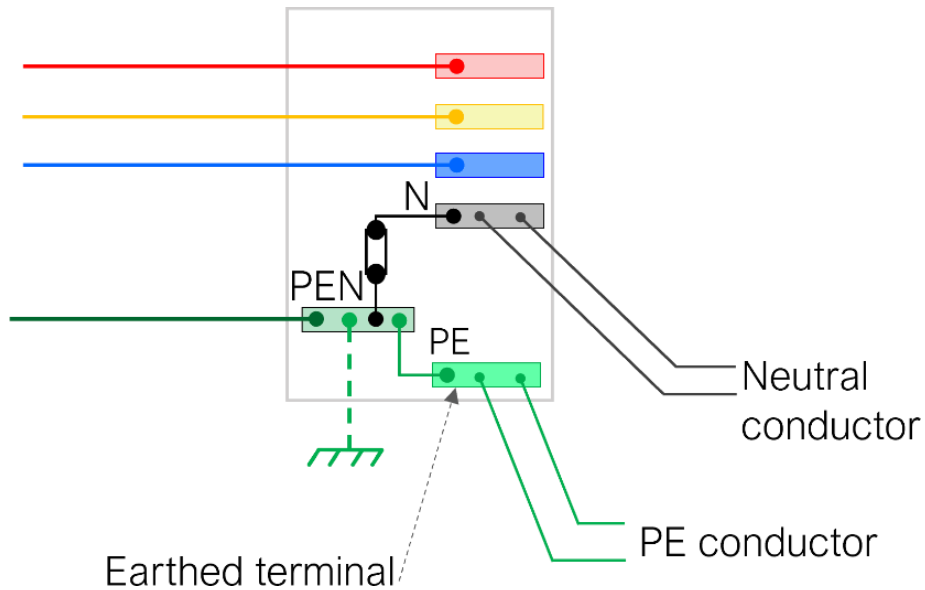

Fig. 13 Typical Connection Diagram of a PEN Conductor in a TN-C-S Network and Separation of PE Conductor Through a Link (Case 3).

21 MAINTENANCE OF SERVICE LINES

21.1 Underground Services

Normally, very little maintenance is required for underground services. The maintenance of the service lines includes inspection, maintenance and care of all cable termination boxes or devices, earthing devices, cutouts, cutout boards and its connections, etc.

21.1.1 Whenever the service cable or joints are accessible as in manholes, ducts, etc, periodical inspection should be made so that timely repairs can be carried out before the cables or joints actually cause interruption of supply to the service.

21.1.2 The frequency and details of schedules of inspection should be determined by each electric supply undertaking from its own experience. Important and/or heavily loaded service cables will require more attention.

21.1.3 Repairs to service cables involve replacement of a section of the defective cable or replacement of the entire cable as the case may be. In most cases where the insulation has not been damaged severely, or where moisture has not obtained ingress into the insulation, it may only be necessary to install a joint at the point of cable failure.

21.2 Overhead Service Lines - The overhead lines should be inspected periodically for maintenance purposes to detect any faults which may lead to breakdown of electric supply and necessary repairs should be done immediately. The main points to be noted while inspecting, are given below and repair action should be taken immediately:

- a) Tilted poles, deformed cross-arms and earth wire supports; settled or bulging soil around pole foundations; yielding of foundation, cracks or breaks in the poles above the ground level; missing nuts; rust and cracks; missing nuts on anchor bolts and rotting of wood crossarms or stump post where used.
- b) kite strings and other extraneous matters, excessive or loose sag, improper clearance and conductor corrosion.
- c) Deterioration of insulation of service lines.
- d) Broken porcelain, burnt and fused spots on the glaze, burning of insulator and fittings; dirty insulator, spindles slipping out of insulator caps, bent pins, and rusty fittings.
- e) Damaged or broken earth wire at the ground level, missing conductor, fixing stapples on supports and missing clamps at the tops.
- f) Loose stays and inadequate stays.
- g) The trees which have become dangerous for the lines and require felling or trimming.
- h) Bird nests, loose jumpers, jumpers jumbling on the poles and overhead jumpers.
- j) Many breakdowns including slipping of conductor due to loose clamps, cracks in the porcelain of insulator and defects on the suspension fittings can only be discovered or seen by going on top of every pole. This inspection should be carried out at frequencies depending on local conditions.

- k) The metal poles should be checked at random after every 6 years to detect any rust at the joints. The underground parts are also liable to corrosion and therefore, should be inspected for effecting any repairs or replacement.
- m) The conductor clearance should be checked periodically as they are likely to be changed due to a variety of service conditions.
- n) The continuity of the earth and operation of safety devices as provided should be checked periodically.
- p) Renewal of the anticorrosive grease for aluminum to aluminum joints.

22 SERVICE RECORDS

22.1 It is recommended to prepare and keep up-to-date permanent records of all service lines, such records are necessary for extensions or diversions of the existing services and for locating of faults on service cable.

22.2 The following data should be given in the service records:

- a) Service number;
- b) Name of the requisitioner;
- c) Address where the service line is installed;
- d) Size and type of service line;
- e) Location of the run and termination of the service line in relation to the street, kerb line and properties, etc;
- f) Positions of all joints;
- g) Accurate lengths of the service cable from joint to joint or from the distributing mains to service termination point; and
- h) Date of laying and jointing the service line.

22.3 Typical examples of these records in the form of sketches are given in **Fig. 14, 15 and 16**.

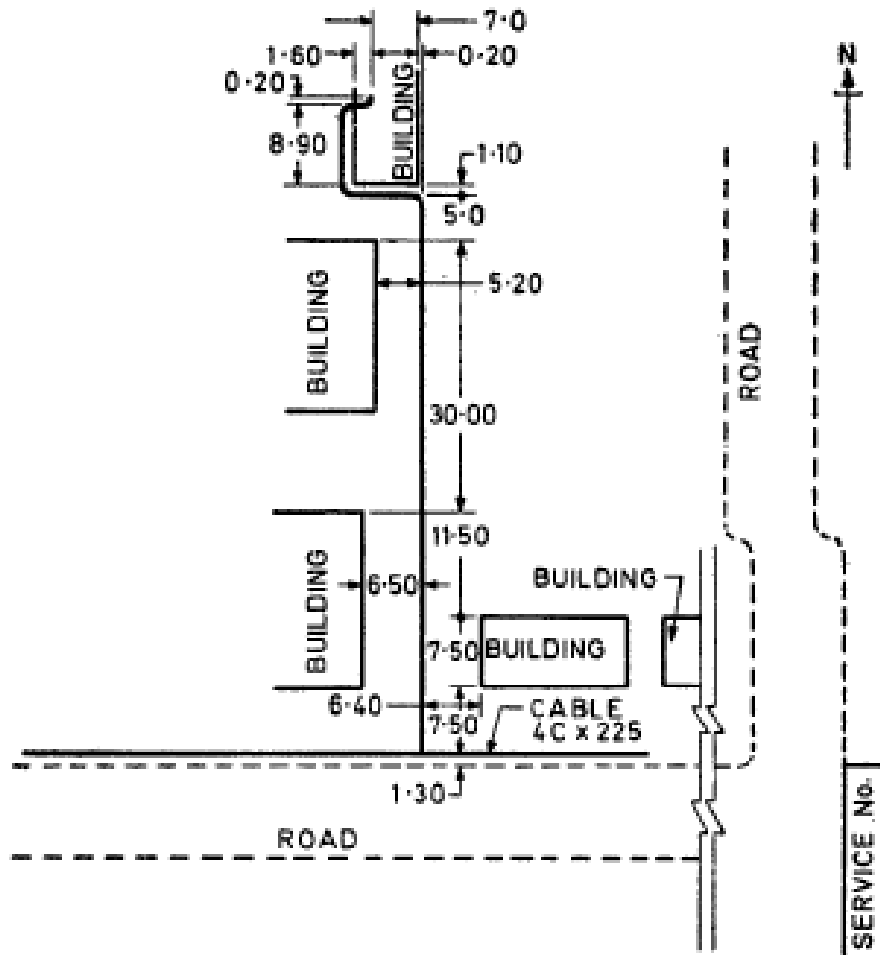

All dimensions in millimetres.

Fig. 14 Typical Diagram Showing Service Line Teed To a Distributor.

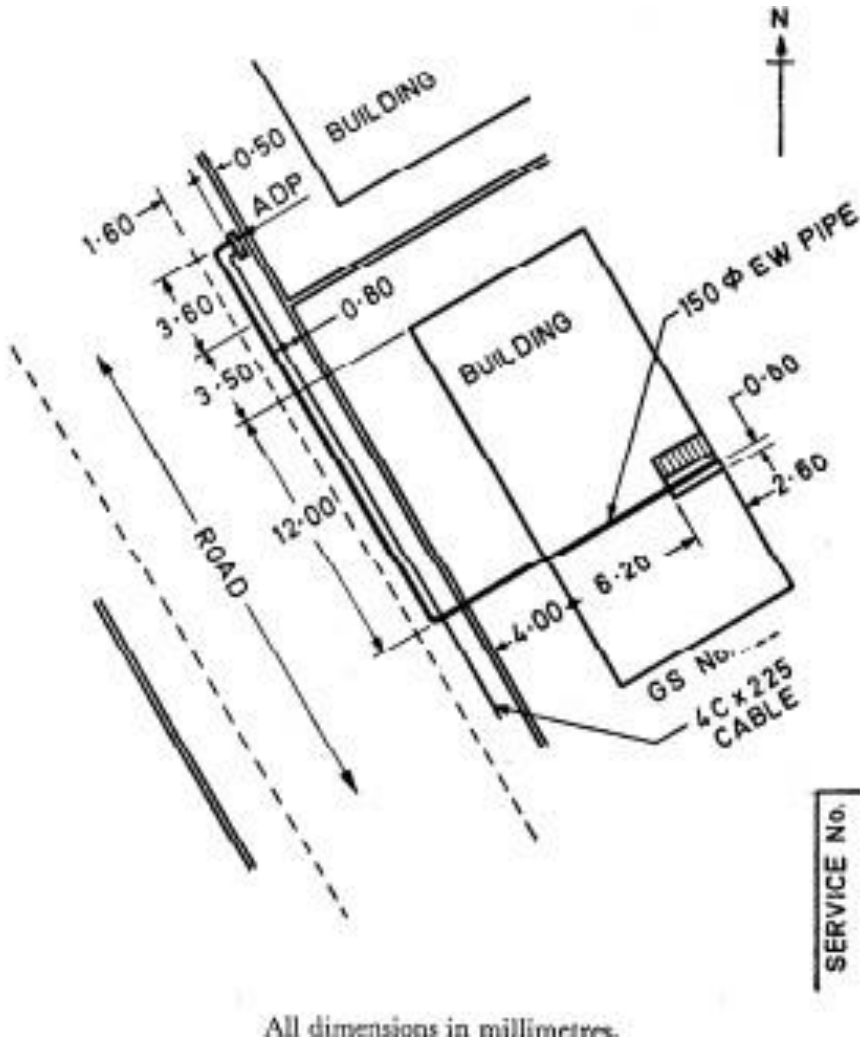

Fig. 15 Typical Diagram Showing Service Line Connected to a Distribution Pillar

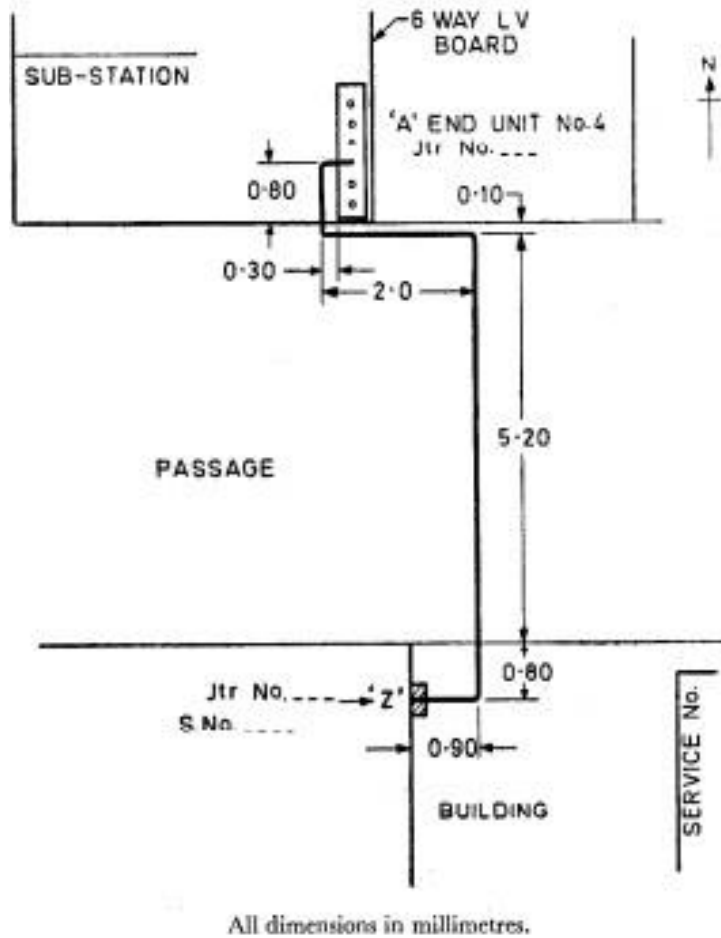

Fig. 16 Typical Diagram Showing Service Line Connected to A Low Voltage Distribution Board of A Sub-Station.

ANNEX A

<i>IS Number</i>	<i>Title</i>
IS 3961-1:1967	Recommended current ratings for cables: Part 1 Paper - Insulated lead - Sheathed cables
IS 3961-2:2017	Recommended current ratings for cables: Part 2 PVC insulated and PVC sheathed heavy duty cables (<i>First Revision</i>)
IS 3961-3:1968	Recommended current ratings for cables: Part 3 Rubber insulated cables
IS 3961-5:1968	Recommended current ratings for cables: Part 5 PVC insulated light duty cables
IS 3961-6: 2016	Recommended Current Ratings for Cables Part 6 Crosslinked Polyethylene Insulated PVC Sheathed Cables
IS 3961-7: 2017	Recommended Current Ratings for Cables Part 7 Crosslinked Insulated Thermoplastic Sheathed Cables
IS 1255:1983	Code of practice for installation and maintenance of power cables up to and including 33 kV rating (<i>Second Revision</i>)
IS 732:2019	Code of practice for electrical wiring installations (<i>Fourth Revision</i>)
IS 5613 (Part 1/Sec 1):1985	Code of practice for design, installation and maintenance of overhead power lines: Part 1 lines up to and including 11 kV Sec 1 design (<i>First Revision</i>)
IS 5613 (Part 1/Sec 2):1985	Code of practice for design, installation and maintenance of overhead power lines: Part 1 lines up to and including 11 kV Sec 2 installation and maintenance
IS 3043:2018	Code of practice for earthing (<i>Second Revision</i>)
IS 694: 2010	Polyvinyl chloride insulated unsheathed and sheathed cables/cords with rigid and flexible conductor for rated voltages up to and including 450/750 v (<i>Fourth Revision</i>)
IS/IEC 61936-1 SP-30	Power installations exceeding 1 kV ac Part 1: Common Rules National Electrical Code of India 2023 (<i>Second Revision</i>)

ANNEX B

Protection of low-voltage installations against temporary over-voltages due to earth faults in the high-voltage system and due to faults in the low voltage system

B.1 The rules of this clause provide requirements for the safety of low-voltage installation in the event of

- a) a fault between the high-voltage system and earth in the transformer substation that supplies the low-voltage installation,
- b) a loss of the supply neutral in the low-voltage system,
- c) a short-circuit between a line conductor and neutral,

NOTE — IT systems are not considered in this clause, since it is not practiced in India.

B.1.1 The requirements for the earthing arrangement at the transformer substation are given in IS/IEC 61936-1.

Faults between a high-voltage line and the earth in the HV/LV substation.

This clause gives rules for the designer and installer of the substation. It is necessary to have the following information concerning the high-voltage system:

- a) quality of the system earthing;
- b) maximum level of earth fault current;
- c) resistance of the earthing arrangement.

The following subclauses consider situations, which generally cause the most severe temporary over-voltages:

- a) fault between the high-voltage system(s) and earth (*see B.2*);
- b) loss of the neutral in a low-voltage system (*see B.3*);
- c) short-circuit in the low-voltage installation (*see B.4*).

The following symbols are used for further explanation.

I_E part of the earth fault current in the high-voltage system that flows through the earthing arrangement of the transformer substation.

R_E resistance of the earthing arrangement of the transformer substation.

R_A resistance of the earthing arrangement of the exposed-conductive-parts of the equipment of the low-voltage installation.

R_B resistance of the earthing arrangement of the low-voltage system neutral, for low-voltage systems in which the earthing arrangements of the transformer substation and of the low-voltage system neutral are electrically independent.

U_o in TN- and TT-systems: nominal a.c. r.m.s. line voltage to earth

U_f power-frequency fault voltage that appears in the low-voltage system between exposed conductive parts and earth for the duration of the fault.

U_1 power-frequency stress voltage between the line conductor and the exposed conductive parts of the low-voltage equipment of the transformer substation during the fault.

U_2 power-frequency stress voltage between the line conductor and the exposed conductive parts of the low-voltage equipment of the low-voltage installation during the fault.

NOTES

1. The power-frequency stress voltage (U_1 and U_2) is the voltage that appears across the insulation of low voltage equipment and across surge protective devices connected to the low-voltage system.
2. An earthing arrangement may be considered electrically independent of another earthing arrangement if a rise of potential with respect to earth in one earthing arrangement does not cause an unacceptable rise of potential with respect to earth in the other earthing arrangement. *See* IS/IEC 61936-1.

Over-voltages in LV-systems during a high-voltage earth fault

In case of a fault to earth on the HV-side of the substation including faults created due to failure of HV surge arresters, the following types of overvoltage may affect the LV-installation:

- a) power frequency fault-voltage (U_f);
- b) power frequency stress-voltages (U_1 and U_2).

Table B1 provides the relevant methods of calculation for the different types of over-voltages.

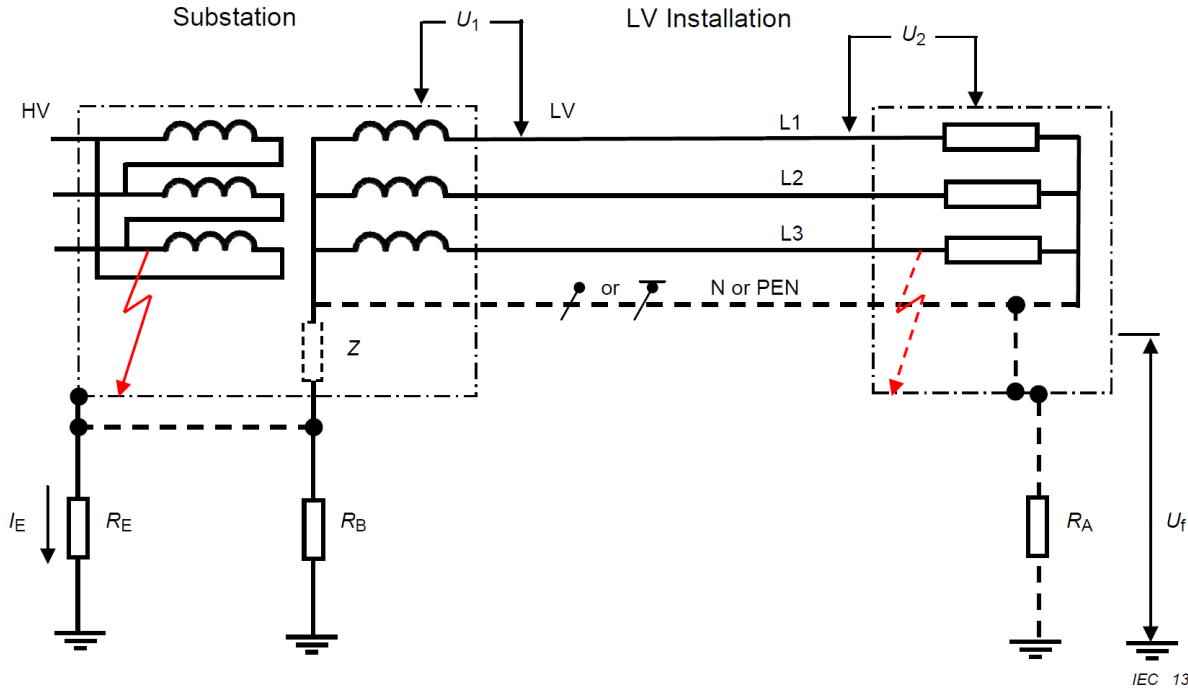

Figure B1 – Representative schematic sketch for possible connections to earth in substation and LV-installation and occurring over-voltages in case of faults

Where high- and low-voltage earthing systems exist in proximity to each other, two practices are presently used:

- a) interconnection of all high-voltage (R_E) and low-voltage (R_B) earthing systems;
- b) separation of high-voltage (R_E) from low-voltage (R_B) earthing systems.

The general method used is interconnection. The high- and low-voltage earthing systems shall be interconnected if the low-voltage system is totally confined within the area covered by the high-voltage earthing system (*see* IS/IEC 61936-1).

Types of system earthing	Types of earth connections	U_1	U_2	U_f
TT	R_E and R_B connected	$U_o^*)$	$R_E \times I_E + U_o$	$0^*)$
	R_E and R_B separated	$R_E \times I_E + U_o$	$U_o^*)$	$0^*)$
TN	R_E and R_B connected	$U_o^*)$	$U_o^*)$	$R_E \times I_E^{**})$
	R_E and R_B separated	$R_E \times I_E + U_o$	$U_o^*)$	$0^*)$

Table B1 – Power-Frequency Stress Voltages and Power-Frequency Fault Voltage in Low-Voltage System

NOTES

1. The requirements for U_1 and U_2 are derived from design criteria for insulation of low-voltage equipment with regard to temporary power-frequency overvoltage (*see* also **Table B2**).
2. In a system whose neutral is connected to the earthing arrangement of the transformer substation, such temporary power-frequency overvoltage is also to be expected across insulation which is not in an earthed enclosure when the equipment is outside a building.
3. In TT- and TN-systems the statement “connected” and “separated” refers to the electrical connection between R_E and R_B .

B.2 Magnitude and duration of power-frequency fault voltage

The magnitude and the duration of the fault voltage U_f (as calculated in **Table B1**) which appears in the LV installation between exposed-conductive-parts and earth, shall not exceed the values given for U_f by the curve of **Figure B2** for the duration of the fault.

Normally, the PEN conductor in a TN-C-S system is connected to earth at more than one point at the distribution. In this case, the total resistance is reduced. For these multiple grounded PEN conductors, U_f can be calculated as:

$$U_f = 0.5 R_E \times I_E$$

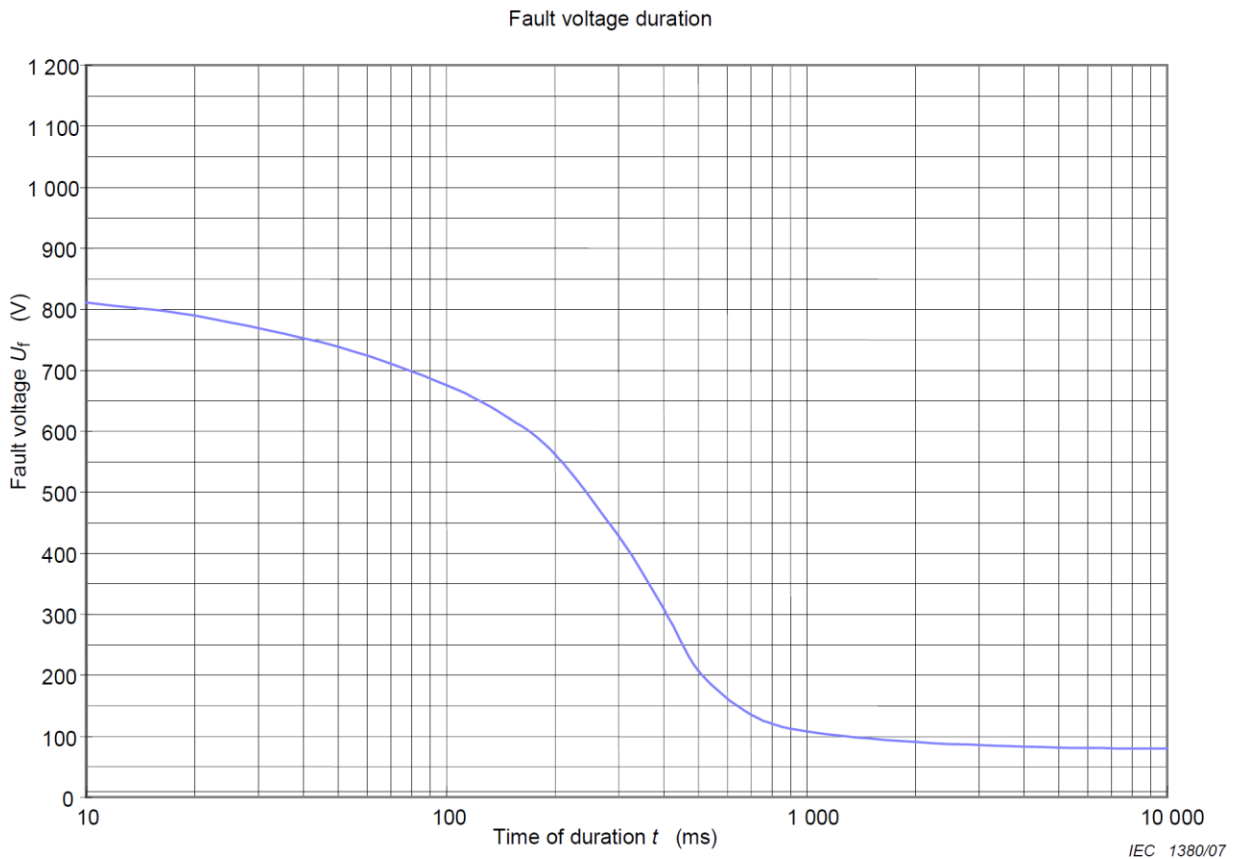

Fig. B2 Tolerable Fault Voltage Due to an Earth-Fault in The HV System

NOTE— The curve shown in **Figure B2** is taken from IS/IEC 61936-1. On the basis of probabilistic and statistical evidence this curve represents a low level of risk for the simple worst case where the low voltage system neutral conductor is earthed only at the transformer substation earthing arrangements. Guidance is provided in IS/IEC 61936-1 concerning other situations.

B.2.1 Magnitude and duration of power-frequency stress voltages

The magnitude and the duration of the power-frequency stress voltage (U_1 and U_2) as calculated in **Table B1** of the low-voltage equipment in the low-voltage installation due to an earth fault in the high-voltage system shall not exceed the requirements given in **Table B2**.

Duration of the earth fault in the high-voltage system	Permissible power-frequency stress voltage on equipment in low-voltage installations
t	U
>5 s	$U_o + 250 \text{ V}$
$\leq 5 \text{ s}$	$U_o + 1\,200 \text{ V}$
In systems without a neutral conductor, U_o shall be the line-to-line voltage.	
NOTE 1 The first line of the table relates to high-voltage systems having long disconnection times, for example, isolated neutral and resonant earthed high-voltage systems. The second line relates to high-voltage systems having short disconnection times, for example low-impedance earthed high-voltage systems. Both lines together are relevant design criteria for insulation of low-voltage equipment with regard to temporary power frequency overvoltage, see IEC 60664-1.	
NOTE 2 In a system whose neutral is connected to the earthing arrangement of the transformer substation, such temporary power-frequency overvoltage is also to be expected across insulation which is not in an earthed enclosure when the equipment is outside a building.	

Table B2 – Permissible Power-Frequency Stress Voltage

B.3 Requirements for calculation of limits

Where required by **Table B1**, the permissible power-frequency stress voltage shall not exceed the value given in **Table B2**.

Where required by **Table B1**, the permissible power-frequency fault voltage shall not exceed the value given in **Figure B2**.

The requirements of **B.2** and **B.2.1** are deemed to be fulfilled for installations receiving a supply at low-voltage from a public electricity distribution system.

To fulfil the above requirements, coordination between the HV-system operator and the LV system installer is necessary. Compliance with the above requirements mainly falls into the responsibility of the substation installer/owner/operator who needs also to fulfil requirements provided by IS/IEC 61936-1. Therefore the calculation for U_1 , U_2 and U_f is normally not necessary for the LV system installer.

Possible measures to fulfil the above requirements are e.g.

- a) separation of earthing arrangement between HV and LV;
- b) change of LV system earthing;
- c) reduction of earth resistance RE.

B.4 *Power-frequency stress voltage in case of loss of the neutral conductor in a TN and TT system*

Consideration shall be given to the fact that, if the neutral conductor in a multi-phase system is interrupted, basic, double and reinforced insulation as well as components rated for the voltage between line and neutral conductors can be temporarily stressed with the line-to-line voltage. The stress voltage can reach up to $U = \sqrt{3} U_0$.

B.5 *Power-frequency stress voltage in the event of a short-circuit between a line conductor and the neutral conductor*

Consideration shall be given to the fact that if a short-circuit occurs in the low-voltage installation between a phase conductor and the neutral conductor, the voltage between the other line conductors and the neutral conductor can reach the value of $1.45 \times U_0$ for a time up to 5 s.