

For BIS Use Only

BUREAU OF INDIAN STANDARDS
DRAFT FOR COMMENTS ONLY

(Not to be reproduced without the permission of BIS or used as a STANDARD)

Draft Indian Standard

**SPECIFICATION FOR
RUBBER AND PLASTICS CONTAINERS FOR
LEAD-ACID STORAGE BATTERIES**

(ICS 29.220.20)

Secondary Cells And Batteries
Sectional Committee ETD 11

Last Date of Comments: 23 March 2025

FOREWORD

(Formal clauses will be added later)

This standard was first published in 1960 and covered the requirements of hard rubber containers of monoblock construction for lead-acid storage batteries used in motor vehicles only. Later the standard was modified to include hard rubber containers for other types of batteries also, except those for aircrafts and miners' cap lamps.

The first revision was done in 1972 in which the scope of the standard was extended to cover the requirements for plastics containers as well as the requirements for aircraft and miners' cap-lamp battery containers.

The second revision was undertaken in 1981 to cover the requirements of fibre reinforced plastics containers. The hydraulic thrust endurance test was added for FRP single-cell containers to determine the ability of the containers to withstand the thrust exerted by the liquid columns around the cell.

The third revision of this standard is undertake for correct editorial mistakes and to modify the High voltage test.

The requirements of this standard are not applicable to trays in which individual cells are assembled.

For the purpose of deciding whether a particular requirement of this standard is complied with, the final value, observed or calculated, expressing the result of a test, shall be rounded off in accordance with IS 2: 2022 "Rules for Rounding off Numerical Values (*Second Revision*)."

The number of significant places retained in the rounded off value should be the same as that of the specified value in this standard.

1 SCOPE

1.1 This standard specifies the requirements and methods of tests for rubber and plastics (with or without reinforcement) containers of single-cell or monobloc construction for all types of lead acid batteries.

2 REFERENCE

<i>IS No.</i>	<i>Title</i>
IS 1885 (Part 15) : 2008	Electrotechnical vocabulary: Part 15 primary and secondary cells and batteries (Second Revision)
IS 2: 2022	Rules for Rounding Off Numerical Values (Second Revision)
IS 266 : 1993	Sulphuric acid - Specification (Third Revision)

3 TERMINOLOGY

For the purpose of this standard, the definitions given in IS 1885 (Part 15) in addition to the following shall apply.

3.1 Type Tests — Tests carried out to prove conformity with the requirements of this standard. These are intended to prove the general quality and design of a given type of container.

3.2 Acceptance Tests — Tests carried out on samples selected from a lot for the purpose of verifying the acceptability of the lot. All containers of the same type, design and rating

3.3.1 Lot — Manufactured by the same factory during the same period, using the same process and materials, offered for inspection at a time shall constitute a lot.

3.3 Routine Tests — Tests carried out on every container.

3.4 Individual Specification — A specification that lays down the requirements and tests which are applicable to a particular type of battery and makes a reference to this standard for general requirements and methods of tests.

4 CONSTRUCTIONAL REQUIREMENTS

4.1 The container shall be designed and manufactured so as to withstand the normal conditions of service.

4.2 The surface of the container shall have a finish substantially free from blisters, rough spots, scales, blow holes and other imperfections or deformations.

4.3 The handle bars, if provided, shall have adequate strength.

5 DESIGNATION

5.1 The materials of the cell container shall be denoted by letter codes as follows:

R = Rubber, hard

P = Plastics

F = Plastics, fibre reinforced

5.2 In case of containers of monobloc construction another letter M shall precede the code for material of the container, for example MR or MP.

6 DIMENSIONS

6.1 The dimensions of containers for cells or batteries shall be as given in the individual specification.

7 MARKING AND PACKING

7.1 The container or the label attached firmly to the container shall be marked with the following information:

- a) Manufacturer's name and/or trade mark;
- b) Material code designation (see **5**);
- c) Month and year of manufacture; and
- d) Country of origin.

Note – This marking applicable in case of containers which are manufactured and supplied to a third party.

7.1.1 *BIS certification marking.*

The product may also be marked with the standard mark.

7.1.2 The use of the Standard Mark is governed by the provision of Bureau of Indian Standards Act, 2016 and the Rules and Regulations made thereunder. The details of conditions under which the license for the use of the Standard Mark may be granted to the manufacturers or the producers may be obtained from the Bureau of Indian Standards.

7.2 Packing — The container shall be so packed that there is no damage or loss during transportation.

8 TESTS AND REQUIREMENTS

8.1 Classification of Tests

8.1.1 *Type Tests* – The following shall constitute the type tests:

- a) Verification of constructional requirements (**8.2**);
- b) Verification of marking and packing (**8.3**);
- c) High voltage test (Type Test) (**8.4**);

- d) Izod impact test (8.7);
- e) Drop ball test (8.8);
- f) Plastic yield test (8.9);
- g) Acid resistance test (8.10);
- h) Hydraulic thrust endurance test (8.11).

8.1.1.1 *The number of samples and the sequence of type tests shall be in accordance with 8.1.1.2.*

8.1.1.2 *Four containers shall be taken and the test shall be carried out in the order indicated.*

<i>Test</i>	<i>Sample Number</i>			
Verification of constructional requirements	x	x	x	x
Verification of marking and packing	x	x	x	x
High voltage test	x	x	x	x
Hydraulic thrust endurance test	x	x	—	—
Drop ball test	—	—	x	x
Plastic yield test	x	x	—	—
Acid resistance test	—	—	x	x
Izod impact test	x	x	—	—

8.1.1.3 *If any of the samples fails in the relevant type tests, the testing authority may call for fresh samples not exceeding twice the original number and subject them again to all test(s) in which failure occurred.*

If there is any failure in any of the retest(s), the type shall be considered as not having passed the requirements of this standard.

8.1.2 Acceptance Tests — The following shall constitute the acceptance tests:

- a) Verification of constructional requirements (8.2);
- b) Verification of marking and packing (8.3); and
- c) High voltage test (Acceptance Test) (8.5).

8.1.2.1 *A recommended sampling plan and criteria for acceptance is given in Appendix A.*

8.1.3 Routine Test — High voltage test (Routine Test) (8.6).

8.2 Verification of Constructional Requirements — The container shall meet the requirements specified under 4.

8.3 Verification of Marking and Packing — The container shall meet the requirements of 7.

8.4 High Voltage Test

8.4.1 This test is intended to determine whether cracks or other imperfections exist in the container walls and base, and partitions (in case of monobloc containers). The voltage is so applied that all the walls, base and partitions are subjected to electrical stresses.

8.4.2 Procedure

8.4.2.1 *For containers of single cells there shall be two electrodes, the inner and the outer. The inner electrode of metal shall fit closely over the internal surfaces of the cells. The outer electrode shall consist of metal plates or bands in close contact with the external surfaces of the walls and the base of the container. The electrodes shall cover all the container surfaces with the exception that minimum distance necessary to prevent flashover shall be provided between the inner and the outer electrodes.*

8.4.2.2 *For monobloc containers there shall be one outer electrode and as many inner electrodes as there are compartments. These electrodes shall meet the requirements specified above for electrodes for containers of single cells.*

Note – This method is not suitable for PVC containers.

8.4.2.3 *As an alternative in place of metal electrodes, water or any other conducting medium could be used.*

8.4.3 *An a.c. voltage of nominal frequency 50 Hz and of value $4000 \times t^{1/2} V_{rms}$ for rubber container and $18000 \times t^{1/2} V_{rms}$ for plastic container, and not to exceed a maximum of 40 kV rms, shall be applied for $5s \pm 1s$:*

Where 't' is the minimum thickness in mm of the walls, partitions or base of the container.

- a) Between inner and outer electrodes for single cells; and
- b) Between inner and outer electrodes and between intercell partitions for Monobloc containers.

Calculate test voltage magnitude to be rounded off in accordance with IS: 2.

8.4.4 Requirement — There shall be no break-down or flashover.

8.5 Izod Impact Test — This test shall be applicable only to miners' cap lamp battery containers. This test is intended to determine the ability of the container to withstand the impacts normally experienced during handling and service. The test shall be carried out as specified under Appendix B.

8.5.1 Requirement — When tested in accordance with Appendix B, the average impact strength of 5 tests calculated for 12.7 mm thickness shall be not less than 0.35 Nm.

8.6 Drop Ball Test — This test shall be applicable to all containers except miners' cap lamp battery containers. The test shall be carried out as specified under Appendix C.

8.6.1 Requirement — When tested in accordance with Appendix C, the container shall meet the requirements given in Tables 2 and 3.

8.7 Plastic Yield Test — This test is intended to determine the extent of yield of the container which may occur due to heat developed in the battery. This test shall not be applicable to containers which are placed in trays when in use. This test shall be carried out as specified under Appendix D.

8.7.1 Requirements — When tested in accordance with Appendix D, the average plastic yield shall not be greater than 5.0 mm.

8.8 Test for Resistance to Acid — This test is intended to assess the ability of the container material to resist acid action. The test shall be carried out as specified under Appendix E.

8.8.1 Requirements — When tested in accordance with Appendix E, the requirements specified under **8.8.1.1** to **8.8.1.3** shall be met.

8.8.1.1 *The extractable impurities shall not exceed the following limits.*

Iron	0.001 6 mg/cm ²	of unpainted surface.
Chlorine	0.001 6 mg/cm ²	of unpainted surface.
Manganese	0.001 6 mg/cm ²	of unpainted surface.

TABLE 1 REQUIREMENTS FOR RUBBER CONTAINERS

(Clause 8.6.1)

Sl. No	WALL THICKNESS AT THE POINT OF IMPACT	HEIGHT OF FALL	
		Minimum Average Value	Minimum Single Value
(1)	(2)	(3)	(4)
	mm	mm	mm
i)	Below 7.20	100	75
ii)	7.20 to 7.50	150	100
iii)	7.51 to 8.80	200	150
iv)	Above 8.80	250	200

TABLE 2 REQUIREMENTS FOR PLASTICS CONTAINERS

(Clause 8.6.1)

Sl. No	WALL THICKNESS AT THE POINT OF IMPACT	HEIGHT OF FALL	
		Minimum Average Value	Minimum Single Value
(1)	(2)	(3)	(4)
	mm	mm	mm

i)	Below 2.50	150	100
ii)	2.51 to 4.00	175	125
iii)	4.01 to 6.00	200	150
iv)	Above 6.00	250	200

8.8.1.2 *The change in mass and volume shall be not more than 4.0 mg cm² and 1.2 cm respectively.*

8.8.1.3 *There shall be no significant blistering, warping or distortion of the test piece.*

8.9 Hydraulic Thrust Endurance Test — This test is intended to determine the capability of the container (material as well as design aspects) to resist the thrust exerted by the electrolyte column around the cell element. This test is applicable to FRP single-cell containers only.

8.9.1 The container under test shall be mounted on wooden blocks of size 100 x 100 x 100 mm, placed at four corners. Additional supports may also be provided for bigger sized containers so that the centre to centre distance between any two wooden blocks does not exceed 300 mm.

8.9.2 If any reinforcements have been provided on the container (either incorporated in the body of the container or fitted externally) it shall be tested along with the same.

8.9.3 The overall dimensions (width and length) of the container along the surface shall be measured and recorded at least $\frac{1}{4}$, $\frac{1}{2}$ and $\frac{3}{4}$ of the height.

8.9.4 The container shall be filled with dilute sulphuric acid of specific gravity 1.20 ± 0.01 at ambient temperature to the maximum level (top of container) and left in that state for 24 h, after which dimensions shall be taken at the same places where previous measurements were made.

8.9.5 The percentage bulge shall be calculated as follows: (see also Fig. 1).

$$\text{Percentage bulge on the width} = \frac{\text{Change in width}}{\text{Original width}} \times 100$$

$$= \frac{W' - W}{L} \times 100$$

$$\text{Percentage bulge on the length} = \frac{\text{Change in length}}{\text{Original length}} \times 100$$

$$= \frac{L' - L}{W} \times 100$$

8.9.6 Requirement — The bulges when calculated as above shall not exceed 2.0 percent.

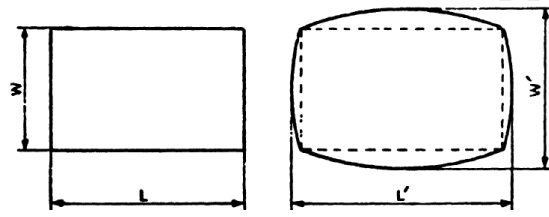

FIG 1 CALCULATION OF BULGE OF CONTAINER

APPENDIX A
(Clause 8.1.2.1)

SAMPLING FOR ACCEPTANCE

A-1 SCALE OF SAMPLING

A-1.1 Lot — In any consignment, all the containers of the same size shall be grouped together to constitute a lot.

A-1.2 Sub-lot — For the purpose of inspection, a consignment, that is, a lot shall be divided into a minimum number of sub-lots, the size of the sub-lot being 1 000 or less. The containers required for testing shall be selected separately from each sub-lot and the acceptance or otherwise of the sub-lot shall be decided on the basis of results of tests on these containers.

A-1.3 The number of containers to be selected from a sub-lot shall depend upon its size and shall be in accordance with Table 4. If necessary, additional number of containers as required for re-test purposes shall be selected from the sub-lot (*see* A-2.2).

TABLE 3 SAMPLE SIZE
(Clauses A-1.3 and A-2.2)

Sl.No	SIZE OF THE SUB-LOT	NUMBER OF CONTAINERS TO BE SELECTED
(1)	(2)	(3)
i)	Up to 200	2
ii)	201 to 500	3
iii)	501 to 800	4
iv)	801 to 1 000	5

A-1.4 These containers shall be selected at random. In order to ensure randomness, all containers in the sub-lot shall be arranged in a serial order and starting from any container taken at random, every r th container shall be included in the sample, r being the integral part of N/n , where N is the size of sub-lot, and n is the sample size.

A-2 CRITERION FOR CONFORMITY

A-2.1 A sub-lot shall be considered as conforming to the requirements of this standard, if all the containers selected from the sub-lot satisfy the requirements of all the tests.

A-2.2 If one or more containers fail to satisfy the requirements of any of the tests, twice the number of containers specified under col 2 of Table 4 shall be selected from the lot and subjected to the tests in which failures occurred. If any one or more of these containers fail, the lot shall be considered as not conforming to the requirements of this standard.

APPENDIX B
(Clauses 8.5 and 8.5.1)

IZOD IMPACT TEST

B-1 PREPARATION OF SAMPLES

B-1.1 At least five test samples of the material of the container shall be cut vertically from the container walls, neglecting strips of 40 mm at the top and bottom of the container.

B-1.2 The samples shall be so prepared that the stress applied by the test is parallel to the wall of the container.

B-1.3 The test specimen shall conform to the dimensions shown in Fig. 2. To ensure the correct contour and condition of the specified notch, all specimens shall be notched as specified in **B-2**.

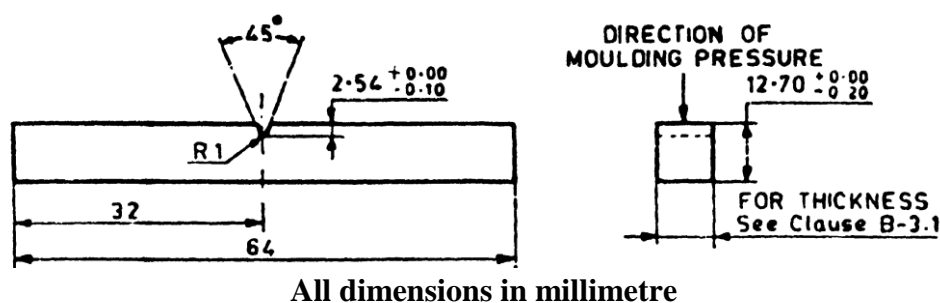

FIG 2 SPECIMEN FOR IZOD IMPACT TEST

B-2 NOTCHING OF SAMPLES

B-2.1 Notching shall be done on a milling machine or shaping machine with a cutter which shall be of the single tooth type. (The single tooth cutter is preferred because it is more readily ground to the desired contour). The cutting edge shall be carefully ground and honed to ensure sharpness and freedom from nicks and burrs, and reproducibility of results.

B-2.2 The profile of the cutting tooth shall be such as to produce in the test specimen, at right angle to its principal axis, a notch of contour and depth as specified in Fig. 2.

B-2.3 The included angle of the notch shall be $45 \pm 10^\circ$ with a radius of curvature of one millimetre at the apex. The plane bisecting the notch angle shall be perpendicular to the face of the test specimen within a tolerance of 2.

B-3 THICKNESS OF SPECIMEN

- B-3.1**
- a) The thickness of the specimen shall be not more than 12.7 mm.
 - b) Where the available thickness of the container is more than 12.7 mm, the thickness shall be reduced to 12.7 mm by removal of the material from one face only.

- c) Where the thickness of the material of the container (hard rubber or plastics) lies between 6.0 and 12.7 mm, the thickness of the specimen shall be the same as the original thickness.
- d) Where the maximum available thickness is less than 6 mm, a composite test piece shall be built up so that the thickness lies between the range, 6.0 mm and 12.7 mm. This composite piece after cementing the individual pieces together by means of a thin layer of adhesive shall be machined to the size shown in Fig. 2.

B-4 CONDITIONING

B-4.1 The samples shall be conditioned for 24 h in circulating air at a temperature of $27 \pm 20C$ before the test is carried out.

B-5 APPARATUS

B-5.1 Cantilever Beam (Izod Type) Testing Machine – The machine shall be of the pendulum type, rigid in construction, and accurate to 0.001 4 kg-m for readings of less than 0.14 kg-m and to one percent for higher value. Accurate correction shall be made for friction and windage losses.

B-5.1.1 The dimensions of the machine shall be such that the centre of percussion of the striker coincides with the centre of the striking edge.

B-5.2 The pendulum shall be released from such a position that the linear velocity of the centre of the striking edge (centre of percussion) at the instant of impact shall be between 2.4 m/s and 3.4 m/s.

B-5.3 The striking edge of the pendulum shall be cylindrical surface of 3.2 mm radius, with its axis horizontal. When the pendulum is hanging free, the cylindrical surface shall be tangential to the specimen in a line 22.0 ± 0.5 mm above the top surface of the vice (see Fig. 3)

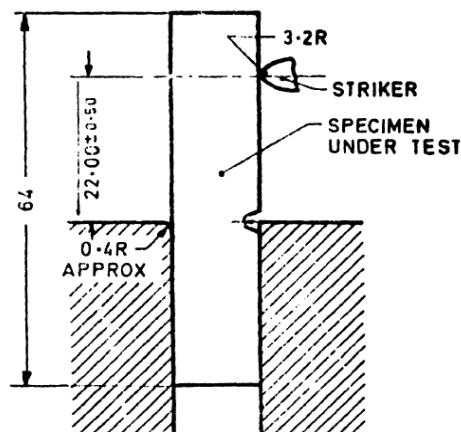

All dimensions in millimetre

FIG 3 POSITION OF TEST SPECIMEN FOR IZOD IMPACT TEST

B-5.4 The pendulum above the cylindrical portion of the striking edge shall be recessed or inclined at a suitable angle so that there is no chance of its coming in contact with the specimen during the break.

B-5.5 Means shall be provided for determining the impact value of the specimen, which is the energy expended by the machine in breaking the specimen. This value is equal to the difference between the energy in the pendulum blow and the energy remaining in the pendulum after breaking the specimen, after suitable correction has been made for windage and friction.

B-6 PROCEDURE

B-6.1 At least five samples shall be tested.

B-6.2 The test specimen shall be rigidly clamped (see Fig. 3) with the centre line of the notch on the level of the top of the clamping surface and the blow shall be struck on the notched side.

B-6.3 The value of energy expended in breaking each individual specimen shall be noted, and the average shall be taken as the impact resistance of the material expressed in Nm.

B-7 CALCULATION

B-7.1 The impact strength of the material shall be calculated for samples with dimension t if other than 12.7 mm, from the following formula:

Impact strength in Nm

$$\text{per 12.7 mm width} = \frac{a}{t} \times 12.7$$

where

a = the average value of impact energy observed for five test specimens, and
 t = thickness of specimen.

APPENDIX C
(Clause 8.6 and 8.6.1)

DROP BALL TEST

C-1 CONDITION AND PREPARATION OF SPECIMEN

C-1.1 Conditioning — A container, free from mechanical damage, shall be permitted to rest for not less than 24 h after manufacture.

C-1.2 Preparation

C-1.2.1 The container shall be laid on its longer side on a 12.5 mm thick steel plate. The container shall be levelled (by placing spacers underneath), flush with the container bottom surface at the back to compensate for the thickness of the top band.

C-1.2.2 The impact test equipment shall be set on the container with the base approximately flush with the front edge and centred so that the steel weight shall strike the container midway between the ribs at approximately the same place, if the container has rib, or midway between the partitions of the centre cell, and approximately one-third the distance from the top edge of the container.

C-1.2.3 Spacers or adjusting screws may be used under the back edge to level the impact equipment to compensate for the top band of the container.

C-1.2.4 A small low wattage lamp may be clipped inside the container to aid in detecting cracks.

C-2 TEST PROCEDURE

C-2.1 A weight of one kilogram (in the shape of a solid steel sphere) shall be suspended from an electro-magnet and the distance of the first drop shall be the single minimum value specified in Table 1 for rubber containers and that specified in Table 2 for plastics containers. Each additional drop shall be increased by 25 mm until a crack appears on the inner surface. The weight should be prevented from striking the specimen more than once on each drop before being caught on the rebound.

C-2.2 The inner surface shall be visually examined after each drop to determine if the container has cracked.

C-2.3 That height (in mm) from which the ball when dropped causes the container to fracture shall be taken as the impact limit of that side of the container.

C-2.4 The container shall then be turned over and the test repeated on the other side.

C-2.5 The average of the two readings shall be considered as the impact limit of the whole container.

APPENDIX D
(Clauses 8.7 and 8.7.1)

PLASTIC YIELD TEST

D-1 PREPARATION AND CONDITIONING OF SPECIMEN

D-1.1 Preparation – Three test specimens shall be cut vertically from the container walls, eliminating strips of 40 mm at the top and the bottom of the container.

D-1.2 The specimens shall be so prepared that the stress applied by the test is parallel to the wall of the container.

D-1.3 The width of each specimen shall be 10 ± 0.1 mm and length $115 +5$ mm.

D-1.3.1 The thickness in case of rubber shall be between 6.25 mm and 12.5 mm. Should the wall thickness exceed 12.5 mm, the specimens shall be reduced to 12.5 mm by removal of the materials from one face only. If the thickness is less than 6.25 mm then two pieces of equal thickness shall be cemented together by using a thin layer of suitable adhesive.

D-1.3.2 Thickness in the case of plastics containers of the samples shall be between 2 mm and 6 mm. Should the wall thickness exceed 6 mm, it shall be reduced to 6 mm by removal of material from one face only. If the thickness is less than 2 mm, then two pieces of equal thickness to be cemented together by a layer of any suitable adhesive.

D-1.4 Conditioning – The specimens shall be conditioned for not less than 24 h in the ambient condition before the test is carried out.

D-2 APPARATUS

D-2.1 The apparatus shown in Fig. 4 shall be used.

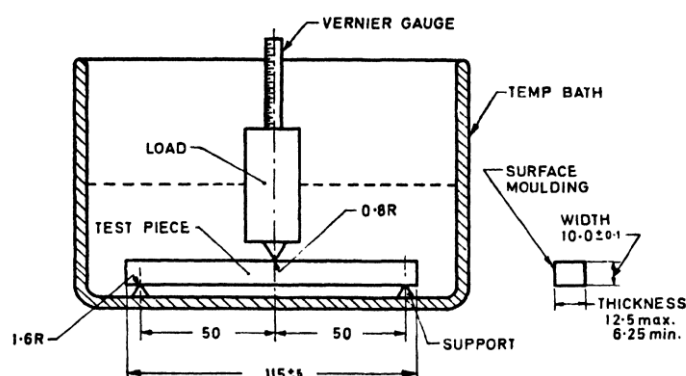

FIG 4 ARRANGEMENT FOR PLASTIC YIELD TEST

D-2.1.1 The supports for the specimen shall be spaced accurately, shall extend beyond the sides of the specimen and have their edges rounded to a radius of 1.6 mm.

D-2.2 The load shall be a weight of one kilogram for specimens of 12.5 mm thickness and proportional lesser weight for specimens of smaller thickness.

D-2.2.1 The load shall be applied centrally between the supports, the weight resting on the specimen through a rounded edge of 0.8 mm radius.

D-2.3 A vernier scale, or a dial indicator, shall be used to observe the deflection of the weight during the test.

D-3 PROCEDURE

D-3.1 After conditioning as specified in D-1.4, the specimens shall be washed in distilled hot water maintained at $60 \pm 50\text{C}$ until the last traces.

D-3.2 The position of the unloaded pile shall first be checked when it is in contact with the test piece and locked in that position. The load shall then be applied to the pile, and the locking device shall be released, the position of the pile with the weight shall be recorded again at the end of 30 min. The difference (in mm) between the two positions shall be taken as the plastic yield of the specimen.

APPENDIX E
(*Clauses 8.8 and 8.8.1*)

TEST FOR RESISTANCE TO ACID

E-1 OBJECT

E-1.1 This test is intended to assess the ability of the container material to resist acid action.

E-2 PREPARATION OF TEST PIECE

E-2.1 The test piece should preferably be cut from the partition or side walls and shall be of size 100 x 65 mm. The edges of test piece shall be smoothed and painted with a 15 percent solution of polystyrene in toluene. The test piece shall first be washed in dilute hydrochloric acid (1: 9) for a few seconds only, and then rinsed with distilled water until the last traces of hydrochloric acid have been removed. The test piece shall then be dipped in boiling water for 10 seconds, and dried first by shaking and then by means of a filter paper. When dry, the test piece shall be allowed to stabilize at room temperature, weighed and the dimensions accurately measured.

E-3 PROCEDURE

E-3.1 The prepared test piece shall then be immersed in 600 ml of dilute sulphuric acid (sp gr 1.250) in a covered beaker of 800 ml capacity. The beaker shall be maintained at $60 \pm 2.5^{\circ}\text{C}$ for 28 days. The level of the acid shall be kept constant by adding distilled water when necessary. At the end of this period the test piece shall be removed and washed in boiling distilled water until the last traces of sulphuric acid are removed. When dry, the test piece shall be allowed to stabilise at room temperature, weighed and the dimensions accurately measured. Any changes in appearances shall be noted. The volume of the acid shall be measured and the amounts of impurities in it shall be estimated in accordance with IS 266.