

BUREAU OF INDIAN STANDARDS

DRAFT FOR COMMENTS ONLY

(Not to be reproduced without permission of BIS or used as an Indian Standard)

भारतीय मानक मसौदा

वायु प्रदूषण मापने की विधियाँ

भाग 28 वाष्प-चरण कार्बनिक रसायन C3 से nC30 वायु और गैसीय उत्सर्जन में
हाइड्रोकार्बन- पंपएड सॉर्बेंट ट्यूबों द्वारा नमूनाकरण के बाद थर्मल डिऑर्शन (टीडी)
और केशिका गैस क्रोमैटोग्राफी (जीसी) विश्लेषण

Draft Indian Standard

Methods for Measurement of Air Pollution

Part 28 Vapour-Phase Organic Chemicals C3 to nC30
Hydrocarbons in Air and Gaseous Emissions –
Sampling by Pumped Sorbent Tubes Followed by
Thermal Desorption (TD) and Capillary gas
Chromatography (GC) Analysis.

(ICS 13.040.20)

Air Quality Sectional Committee, CHD 35

Last Date for Comments: 03 August 2024

Air Quality Sectional Committee, CHD 35

FOREWORD

(Formal clause will be added later)

This Indian Standard addresses a wide range of air monitoring applications and is prepared in two parts. Part A covers pumped sampling of vapour phase organic chemicals onto sorbent tubes followed by analysis using thermal desorption - gas chromatography (TD-GC). Compatible matrices include ambient air, indoor/in-vehicle air, workplace air, product emission testing plus industrial (fugitive or stack) emissions. Target compounds include the important pollutants benzene, toluene and xylene, together with industrial solvents, fuel components, odorous compounds and many other volatile and semi-volatile organic compounds. Part B covers diffusive (passive) sampling of vapour phase organic chemicals onto sorbent tubes or cartridges followed by TD-GC analysis and addresses similar air monitoring applications.

Useful additional information is provided in various international standards, referenced in each respective sub-part, but this standard harnesses the measuring techniques available and used in India.

In reporting the results of a test or analysis made in accordance with this standard, if the final value, observed or calculated, is to be rounded off, it shall be done in accordance with IS 2 : 2022 'Rules for rounding off numerical values (second revision)'.

Draft Indian Standard

Methods for Measurement of Air Pollution

Part 28 Vapour-Phase Organic Chemicals C3 to nC30 Hydrocarbons in Air and Gaseous Emissions – Sampling by Pumped Sorbent Tubes Followed by Thermal Desorption (TD) and Capillary gas Chromatography (GC) Analysis.

1 SCOPE

1.1 This standard prescribes the method is applicable to measure the vapour-fraction of gas Chromatography GC-compatible organic compounds in ambient, indoor and workplace air and in the air exhausting from product or material emission test chambers. Compatible compounds range in volatility from C3 to n-C30 hydrocarbons at concentrations ranging from low micrograms per cubic metre (low ng/l) to milligrams per cubic metre (high µg/l).

1.2 The list of compounds of interest is given in Annex A, but other organic vapours within the specified volatility range can also be monitored using this method provided they are readily analyzed by gas chromatography

2 REFERENCE

The standards given below contain provisions which, through reference in this text, constitute provisions of this standard. At the time of publication, the editions indicated were valid. All standards are subject to revision, and parties to agreements based on this standard are encouraged to investigate the possibility of applying the most recent editions of these standards.

<i>IS No.</i>	<i>Title</i>
IS 4167	Glossary of Terms Relating to Air Pollution (<i>second revision</i>)
IS 5182(Part 11): 2006	Methods for measurement of air pollution: Part 11 benzene, toluene and xylene (BTX) (<i>second revision</i>)
IS 16247: 2019	Gas analysis - Contents of - Certificates for calibration gas mixtures (<i>first revision</i>)
ISO 13137: 2022	Workplace atmospheres — Pumps for personal sampling of chemical and biological agents — Requirements and test methods

3 TERMS AND DEFINITIONS

For this standard, the definitions given in IS 4167 shall apply

3.1 Breakthrough Volume

Volume of gas standard that can be passed through a sorbent tube before the concentration of the vapour phase compound in the gas eluting from the far end of the tube reaches 5 percent of the applied concentration

NOTE — The breakthrough volume varies with compound, temperature, humidity and with type of sorbent (*see* ISO 16017-1)

3.2 Desorption Efficiency

The ratio of the mass of analyte desorbed to that retained, expressed as a percentage.

3.3 Field Blank

A conditioned sample tube from the batch used for the sampling exercise, subjected to the same handling procedure in the field as the sample tubes, including removal and replacement of storage caps, but not used for sample collection. These tubes are analyzed with the sampled tubes.

3.4 Internal Standard

Readily-distinguished compound of known concentration added to a sample to facilitate the qualitative identification and/or quantitative determination of sample components.

3.5 Laboratory Blank

Conditioned sampling tube from the batch selected for each sampling exercise, retained in the laboratory, sealed with long term storage caps throughout the sampling exercise to be used as a blank tube. These tubes are analyzed with the sampled

tubes.

3.6 Retention Volume

Volume of air or carrier gas that has passed through a sorbent tube, pre-loaded with a small aliquot of the organic vapour at the sampling end, at the point when the concentration of organic compound eluting from the far end of the tube reaches a peak.

NOTE

- 1) The retention volume varies with compound, temperature, humidity and with type of sorbent.
- 2) The retention volume is determined chromatographically (*see* ISO 16017-1).

3.7 Safe Sampling Volume (SSV)

The volume of sampled air below which there is negligible risk of that compound breaking through during sample collection.

NOTE — This is traditionally calculated as 50 percent of the chromatographically-determined retention volume or 70 percent of the breakthrough volume (*see* ISO 16017-1)

3.8 Sorbent Strength

Term to describe the affinity of sorbents for vapour-phase organic chemicals (VOCs); a stronger sorbent is one which offers higher safe sampling volumes for VOCs relative to another, weaker, sorbent.

4 SIGNIFICANCE AND USE

4.1 Convenient sorbent-based sampling together with laboratory GC analysis, is extensively used for the collection of time weighted average concentration data for organic vapours in air and gas. It is applied to workplace, indoor/in-vehicle and ambient air and for material or product emission testing. Two categories of sampler are deployed; those containing charcoal (subsequently desorbed with 1 ml to 2 ml solvent, typically carbon disulfide) and those compatible with thermal desorption [*see* IS 5182 (Part 11)].

4.2 Both solvent extraction (desorption) and thermal desorption (extraction) methods have their place. However, as limit levels fall in industrial environments and as interest grows in ppb-level toxic and odorous pollutants in urban and indoor/in-vehicle air and in product emissions, the significant (1 000 fold) sensitivity advantage of thermal desorption is increasingly necessary to deliver accurate results. Generally speaking, either solvent extraction or thermal desorption methods can be applied to workplace air monitoring but the extra sensitivity of TD methods is required for monitoring indoor, in-vehicle and ambient air and for material emission testing. A more detailed comparison of the two approaches is summarized in informative Annex B.

5 PRINCIPLE

5.1 The method involves pumping a known volume of air through sorbent sampling tubes at a controlled flow rate and for a given time. Subsequent analysis is by thermal desorption (TD) and gas chromatography (GC) employing a capillary column and a mass spectrometric (MS) detector.

This procedure gives a time-weighted average result. It is not applicable to the measurement of rapid fluctuations in concentration or to instantaneous measurements

5.2 The sampling tube is packed with a sorbent or series of sorbents suitable for quantitatively retaining the vapour-phase organic compound(s) of interest from a representative volume of air pumped through the tube at a controlled flow rate. Multiple sorbents (if used) are arranged in series, in order of increasing sorbent strength from the sampling end. Vapour-phase organic components are trapped on the sorbent(s) and removed from the flowing air stream as it passes through the tube. The use of weaker sorbents in front of stronger sorbents extends the volatility range of compounds that can be collected simultaneously. It also prevents irreversible adsorption of higher boiling compounds on the stronger sorbents. Sampled tubes are kept sealed after sampling. They are stored in a clean environment, at or below 25 °C and are analyzed within 4 weeks.

5.3 Sampled tubes are analyzed by two-stage thermal desorption (TD) with capillary gas chromatography (GC) using mass spectrometric (MS) detection. Each tube is loaded into the thermal desorber in turn, checked for leaks and purged of air. It is then heated in a reverse flow of inert carrier gas which releases the retained compounds and sweeps them into an electrically-cooled sorbent focusing trap where they are concentrated. Once primary (tube) desorption is complete, the focusing trap is heated rapidly in a reverse flow of carrier gas to inject the compounds directly into the capillary GC column in a concentrated band of vapour. Desorption from the tube to the focusing trap and from the focusing trap to the column can be split or splitless depending on the air concentrations being monitored and the mass of compounds sampled.

5.4 Secondary (focusing trap) desorption and injection of the organic compounds into the capillary GC column triggers the start of the GC program. The desorbed compounds are separated, measured and identified by the analytical system. The concentration of each organic vapour in the sampled air is then calculated from the measured mass of compound and the volume of air sampled.

6 REAGENTS AND MATERIALS

6.1 **Organic Compounds for Calibration** — Must be of chromatographic quality

6.2 Dilution Solvent

For preparing calibration blend solution for liquid spiking of conditioned sorbent tubes. Shall be of chromatographic quality and free from interfering compounds that could co-elute chromatographically with the compound(s) of interest.

6.3 Solid Sorbents

6.3.1 Multiple sorbents, suitable for packing thermal desorption sample tubes or focusing traps, are available. Sorbents can be classified by material and the most common types used are as follows:

6.3.1.1 *Graphitised carbon black* — examples include Carbograph, Carbo-pack and Carbotrap sorbents

6.3.1.2 *Poly(diphenyl-p-phenylene oxide)* — examples include Tenax TA

6.3.1.3 *Graphitised poly(diphenyl-p-phenylene oxide)* — examples include Tenax GR

6.3.1.4 *Carbon molecular sieve* — examples include Carboxen, Sulficarb and Carbosieve

6.3.2 They range in strength from very strong (retentive) sorbents, required to quantitatively retain and release very volatile substances such as C₃ hydrocarbons, to very weak sorbents, suitable for quantitative sampling and release of high boiling semi-volatiles such as n-C₃₀. The required sorbent particle size is 0.18 mm to 0.60 mm (80 mesh to 30 mesh). Listed in order of increasing sorbent strength starting from the weakest, example TD-compatible sorbents include:

- a) Quartz wool or beads, artefact free, inert and not prone to particle formation
- b) Tenax TA[®] particle size ~0.25 mm to ~0.6 mm (60 mesh to 30 mesh). Tenax TA is an inert, hydrophobic porous polymer based on 2,6-diphenyleneoxide. Suitable for organic compounds ranging in volatility from n-C_{6/7} (depending on air sampling volume) to n-C₂₆ or more.
- c) Carbon black sorbents, such as Carbo-pack X[™] or Carbograph 5 TD[™] particle size 0.25 mm to 0.5 mm (60 mesh to 40 mesh). Hydrophobic carbon sorbents suitable for organic compounds with vapour pressures below those for C₄ hydrocarbons and above those for n-C₁₀.

NOTE — Weaker types of carbon black sorbent are also available.

- d) Carbon molecular sieve sorbents such as Carboxen 1003[™] or Sulficarb[™] are very strong and can be used at the non-sampling end of tubes for trapping compounds more volatile than C₄ hydrocarbons.

NOTE — Carbon molecular sieve sorbents are not completely hydrophobic. If such sorbents are used, the tube will require dry purging in the sampling direction before analysis, to remove residual water.

More information on sorbent selection is given in 7.

6.4 Preparing Calibration Standards on Sorbent Tubes

Target compounds should be calibrated using original reference compounds whenever possible. Standards should be introduced to the sampling end of conditioned sorbent tubes using either liquid or gas phase standards. Table 1 below shows the various calibration range for workplace, ambient and indoor air monitoring. Calibration solution concentrations will vary depending on the concentration of the atmosphere which is being measured. Additional information and illustrative examples for preparing calibration standards suitable for workplace air monitoring, ambient or indoor air monitoring and for material/product emission testing are all given in Annex C.

NOTE — It is advisable to include toluene as one of the compounds in a calibration mix as unknowns are conventionally 'semi-quantified' using the response factor for toluene.

Table 1 Typical Calibration Ranges for each Measurement Atmosphere

(Clause 1)

Measurement Typical minimum Typical maximum Annex C reference for information on how atmosphere mass per μL mass per μL to prepare the correct calibration range

Sl. No	Measurement atmosphere	Typical minimum mass per μL	Typical maximum mass per μL	Section reference
(1)	(2)	(3)	(4)	(5)
i)	Workplace air	5 μg	100 μg	3.1
ii)	Ambient air	0.15 μg	3 μg	3.2
iii)	Indoor air	0.15 μg	3 μg	3.2
iv)	Material/product	0.03 μg	0.6 μg	3.3
v)	testing			

NOTE — Typical calibration ranges for each measurement atmosphere covered in the scope of this document when using the sampling parameters defined in 9.4. To determine the required range required for the experiment refer to Annex B

6.4.1 Gas-phase Standards

6.4.1.1 Standard atmospheres containing known concentrations of the compound(s) of interest are prepared using a recognized procedure such as IS 16247. The concentration(s) of the compounds in the standard atmosphere should be similar to those expected to be collected during the respective field monitoring exercise.

6.4.1.2 Alternatively, gas standards of appropriate quality shall be sourced. The mass of each compound of interest loaded on to the sorbent tube in the introduced aliquot (volume) of gas standard should be similar to the masses expected to be collected during field monitoring.

NOTE

- It is notoriously difficult to produce stable standard atmospheres that are traceable to primary standards, particularly if target compounds include reactive and/or high boiling species. Frequent monitoring of the standard atmosphere is recommended as a check on stability.
- Pressurized gas standards, containing relatively high concentrations of key target compounds are often the most stable and affordable form of gas-phase standard providing the optimum calibration stock for every volatile target analytes, e.g. compounds that are in the gas phase at room temperature.

6.4.2 Loading Sorbent Tubes with Gas-phase Standards

Standard tubes are prepared either by passing a known volume of standard atmosphere through a conditioned sorbent tube from the sampling end (e.g. by means of a pump operating at 50 ml/min) or by introducing a metered volume of depressurized gas standard using a gas syringe or gas sampling valve and mass flow controller. The total volume of gas passing through the sorbent tubes when loading calibration standards shall not exceed the breakthrough volume for any of the compounds of interest. After loading, tubes shall be disconnected and sealed.

Fresh standard tubes should be prepared for each batch of samples.

6.4.3 Liquid Calibration Solutions for Preparing Spiked Sorbent Tubes

6.4.3.1 A series of liquid standard solutions shall be prepared over a range of concentrations such that injecting 1 μL aliquots of each standard onto respective conditioned sorbent tubes introduces the range of analyte masses that is expected to be collected during field monitoring (see 8.3).

6.4.3.2 The selected compound(s) shall be prepared in chromatographic-grade solvent (e.g. in methanol). Liquid standards shall be maintained at a stable temperature. The stability of calibration solutions shall be monitored and a fresh series of standards shall be prepared if there is evidence of deterioration, e.g. reactions between alcohols and ketones.

6.4.4 Loading Sorbent Tubes with Liquid Standards

The sampling end of a conditioned sorbent tube is fitted to some form of unheated injector through which inert gas is passed at 50 ml/min to 100 ml/min (*see 7.7*).

A suitably precise micro-syringe (*see 7.6*) shall be used to inject a maximum 1 µl of standard solution through the septum of the injector and into the tube immediately above the sorbent bed. After 5 minutes, the tube is disconnected and sealed.

NOTE

- a) It is normally recommended to keep injection volumes to 1 µl or below to minimize the risk of solvent interference during subsequent analysis.
- b) Introducing liquid standards onto sorbent tubes in a gas stream via a suitable injector is considered the optimum approach to liquid standard introduction, as volatile components reach the sorbent bed in the vapour phase. However, when preparing standards containing high boiling compounds, analyte transfer is enhanced if the injector allows the tip of the syringe to make gentle contact with the sorbent retaining mechanism (e.g. gauze or quartz wool) at the sampling end of the tube.
- c) If standard tubes are being prepared by introducing aliquots from more than one standard solution or gas, it is appropriate to introduce the standard(s) containing higher boiling components first and those containing the most volatile organic compounds last. This minimizes risk of analyte breakthrough during the standard tube loading process.
- d) The purity of the inert carrier gas used to purge sorbent tubes during standard introduction should be such that 0.5 ng toluene can be measured without significant interference. The quality of the carrier gas is of great importance, as any contaminants contained in the gas are enriched on the sorbent together with the substance to be analyzed (*see 6.7*).
- e) For guidance on estimating the mass of analyte that will be collected on a sorbent tube during pumped monitoring, see Annex C.

Fresh standard tubes shall be prepared for each batch of samples.

6.5 Internal Standards

6.5.1 Suitable internal standard compounds should not be present in the sample and should be readily distinguished from sample components. They should also behave in a similar way, chemically, to the compounds of interest. D-8 toluene or fluorinated aromatic species (*see Fig 6*) are often used, for example, if subsequent analysis is by TD-GCMS.

6.5.2 A gas or liquid-phase internal standard can be added to the sampling end of sample or standard tubes by mixing with the calibration solution or by spiking separately.

NOTE

- a) Internal standards can be added to tubes just before field monitoring (as an extra check on tube transportation and handling procedures in the field) or immediately before analysis, for analytical quality control.
- b) Some makes of automated thermal desorber allow gas phase internal standard to be introduced to the sampling end of tubes or focusing traps automatically, as part of the 2-stage thermal desorption process.

6.6 Certified Standard Tubes Available

6.6.1 Standard tubes pre-loaded with certified masses of representative compounds of interest are available and can be used for establishing analytical quality control and for routine calibration.

6.6.2 Certified reference standards can be purchased from a number of reliable sources.

6.7 Carrier Gas

As thermal desorption is a powerful enrichment (concentration) and desorption technique, it is essential to use the highest quality carrier gas installation. 99.9995 percent is an example of a suitable grade of GC carrier gas.

7 APPARATUS

Ordinary laboratory apparatus and the following:

7.1 Sorbent Tubes

Tubes with outside diameter of 6.4 mm (0.25 inch), inside diameter of 5 mm (stainless steel) or 4 mm (glass), and of length 89 mm (3.5 inch) have been found to work well for this method and are used in many TD systems (*see Fig 1*). Such 'industry standard' tubes typically contain an overall sorbent bed length of 40 mm to 60 mm, retained in the central, directly-heated portion of the tube using stainless steel gauzes, glass constrictions or some other inert mechanism. At least 14 mm air space is left free of sorbent at each end of the tubes to prevent significant error from diffusive ingress.

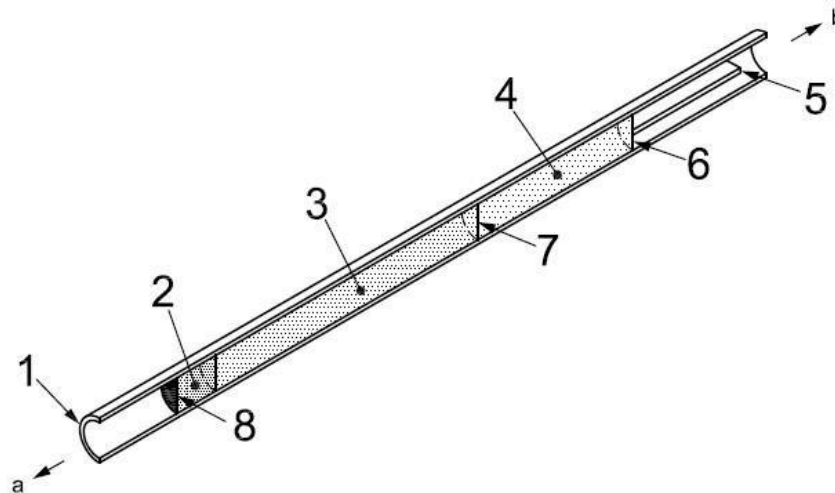

FIG.1 TYPICAL CROSS SECTION OF A METAL TUBE PACKED WITH MULTIPLE SORBENTS

7.1.1 Key

7.1.1.1 Stainless steel or coated steel tube

7.1.1.2 4 mm to 6 mm Quartz wool 7.1.1.3 32-35 mm, ~175 mg Tenax TA®

7.1.1.3 18 mm to 20 mm Stronger sorbent, e.g. Carbograph 5 TD® or Carbopack X®

7.1.1.4 Gauze retaining spring

7.1.1.5 Sorbent retaining gauze

7.1.1.6 Sorbent retaining gauze or 0.5 mm quartz wool

7.1.1.7 Sorbent retaining gauze

- a) desorption gas flow
- b) sampling air flow

Inert-coated stainless steel or glass tubes are preferred if reactive organic compounds are of interest.

Each tube requires a unique alphanumeric identification number. Indelible bar codes or some other form of electronically-read label are also useful. Solvent-containing paints and markers or adhesive labels should not be used on the tubes.

Sample tubes packed with one, two or even three discrete beds of sorbent are available or can be filled in the laboratory. All the sorbents used in a given tube must be separated into discrete beds, compatible in terms of temperature limitations and arranged in order of increasing sorbent strength from the sampling end of the tube.

NOTE

- a) Multi-sorbent air sampling can alternatively be achieved by connecting several single-sorbent tubes together in series to form a sampling train. This enables incompatible sorbents to be combined for sampling but increases costs and complexity during subsequent analysis.
- b) Example breakthrough, retention and safe sampling volumes for standard TD tubes packed with varying sorbents and sorbent combinations are widely published in international standard methods (see 4 and informative Annex A), in the scientific literature and by TD manufacturers. Methods for determining breakthrough and retention volumes are also given in ISO 16017-1.
- c) The factors which have a significant impact on compound breakthrough during sampling include; sorbent strength, sorbent bed length and sorbent temperature. As an approximate measure, doubling the length of a given sorbent while keeping tube I.D. constant doubles the breakthrough volume. Similarly, raising the temperature of the tube by 10 °C during sampling, approximately halves the breakthrough volume.
- d) Strong carbon molecular sieve sorbents are not hydrophobic. The breakthrough volumes of such sorbents may be reduced by as much as a factor of 10 at high (>80 percent RH) humidity.

7.2 Common Sorbent Tube Configurations and Options

7.2.1 Tubes Packed with Tenax TA or quartz + Tenax TA

Tubes packed with approximately 200 mg Tenax TA are suitable for sampling compounds ranging in volatility from around

n-C6/7 to n-C26 and above depending on the performance of the thermal desorber. The recovery of even higher boiling compounds can be enhanced by positioning a 5 mm to 10 mm bed of loosely- packed clean quartz wool before the Tenax at the sampling end, but within the directly heated part of the tube.

NOTE — The density of Tenax TA® can be variable. However, 200 mg of Tenax TA® normally occupies ~40 mm bed depth in a 5 mm bore metal tube and ~60 mm bed depth in a 4 mm bore glass tube.

7.2.2 Tubes Packed with 35mm to 40 mm of Tenax TA backed up with ~20 mm of a Strong Carbon Black such as Carbopack X or Carbograph 5TD

Suitable for quantitative retention and analysis of compounds ranging from 1,3-butadiene to n-C26 and above but without significant water retention from humid atmospheres.

7.2.3 Tubes packed with 35 mm to 40 mm of Carbograph 1 TD backed up with ~20 mm of a Carbonized Molecular Sieve such as Carboxen 1 003

Suitable for quantitative retention and analysis of compounds ranging in volatility from propyne to n-C14. Not completely hydrophobic. Will require dry purging before analysis if used to sample humid air.

7.2.4 Tubes packed with 3 Sorbents (Weak, Medium and Strong) for Screening Uncharacterised Atmospheres

For example; tubes packed with 20-25 mm of Tenax TA, backed up by 15-20 mm of Carbograph 5TD, backed up by 10 mm to 15 mm of a carbonized molecular sieve such as Carboxen 1 003. Suitable for compounds ranging in volatility from C3 to n-C26 hydrocarbons and above.

7.3 Long Term Storage Caps for Conditioned and Sampled Sorbent Tubes

Reliable long-term tube storage caps are a critical component of air monitoring, particularly at trace (ppb and sub-ppb) levels. They are required for transportation and storage of conditioned and sampled tubes to prevent both contaminant ingress and analyte loss. Two-piece metal screw caps fitted with combined Polytetrafluoroethylene (PTFE) ferrules have been found to provide the most secure and readily-available option. Validated studies have shown that they remain effective for many months at ambient and refrigerated temperatures (*see also ISO 16017-1*).

7.4 Storage Containers for Conditioned and Sampled Tubes

Clean, non-emitting containers made of inert materials, such as unused paint cans or aluminium tins and glass jars with an air tight seal, are used for storage and transportation of sealed sorbent tubes before and after exposure. Suitable containers help maintain artefact levels below required levels (*see 12*).

7.5 Sorbent Tube Unions

Metal screw-couplings fitted with combined PTFE ferrules. For connecting tubes together in series for sampling – Identical tubes can be connected together as a check on breakthrough (*see 8.6.3*), or tubes packed with different sorbents can be connected together in a sampling train (*see 7.1*).

7.6 Precision Syringe

Syringe used for injecting liquid standards shall be readable to at least 0.1 µl.

7.7 Injection Facility for preparing standard tubes by injecting liquid (or gas) standards.

Calibration loading rigs designed specifically for spiking TD tubes with liquid or concentrated gas standards in a controlled flow of carrier gas, are available. Alternatively, it is possible to use an unheated packed-column GC injector adapted with a push fit connector and o-ring seal for easy insertion and removal of sorbent tubes without damaging tube ends.

7.8 Monitoring Pump or Pumping System

The monitoring pump (*see Fig. 2*) should be capable of maintaining a controlled flow, typically somewhere between 10 and 200 ml/Min, for the duration of air monitoring. Battery or mains-power operated pumps or mass flow controlled-pump assemblies can be used provided they fulfil the requirements of ISO 13137 and meet any relevant safety requirements – e.g. intrinsic safety, if applicable. The performance of the pump should be such that the flow does not vary more than 5 percent across a monitoring period or across a batch of tubes all packed with nominally the same sorbents.

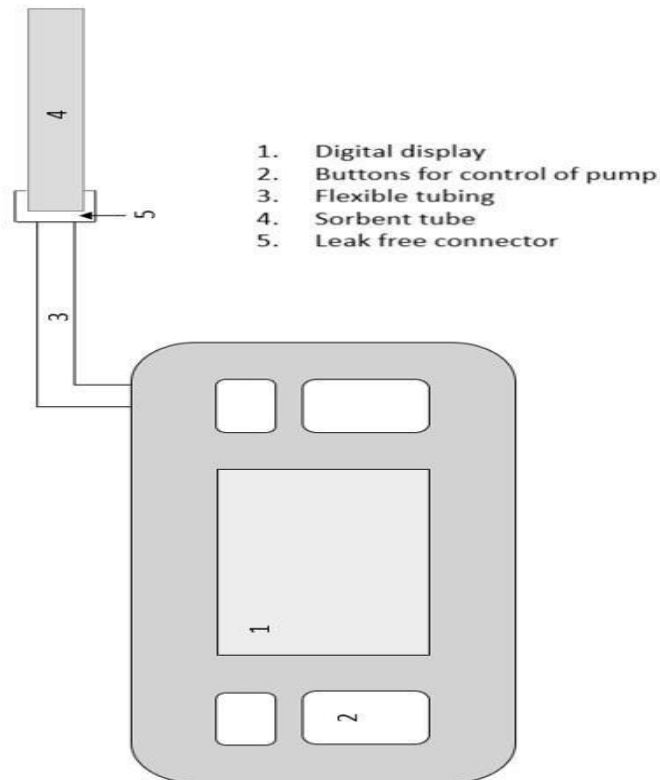

FIG. 2 SCHEMATIC OF A TYPICAL MONITORING PUMP

7.9 Flexible Tubing for Connecting Sorbent Tubes and Pumps

Clean, low-emission flexible tubing of appropriate diameter; used to ensure a leak-proof fit between the non-sampling end of the sorbent tube and the monitoring pump. It shall only be used upstream of the sorbent as interferences from the tubing can introduce contaminants.

7.10 Carrier Gas Installation

Only high-quality, stainless steel diaphragm regulators shall be used on carrier gas cylinders. Carrier gas lines shall be constructed using medical grade tubing and connected using appropriate swage fittings with no brazed joints. Oxygen and organic filters should be installed in the carrier gas lines and maintained regularly.

7.11 Gas Chromatograph (GC),

Fitted with a mass spectrometric detector capable of detecting target compounds at the lowest levels of interest with a signal-to-noise ratio of at least 5 to 1, preferably 10 to 1 under practical routine operating conditions. The GC may also be fitted with a conventional GC detector such as a flame ionization detector (FID) for routine operation if required.

7.12 Capillary GC Column.

A polar or moderately polar, bonded capillary columns of 30 m to 60 m length, with an internal diameter 0.25 mm to 0.32 mm and phase thickness 0.25 μm to 1.0 μm are examples of columns proven to be suitable for analyzing a wide range of trace organic air pollutants. Polar or more specialist columns may also be required for some applications.

7.13 Two-stage Thermal Desorption Apparatus,

7.13.1 To accommodate one or multiple sample tubes which are uploaded into the carrier gas flow path for analysis. During thermal desorption, sorbent tubes are heated with inert (carrier) gas flowing in the reverse direction to the air flow during sampling. Desorbed vapours swept from the sample tube are focused (concentrated) on a small, electrically-cooled sorbent trap which is then itself desorbed by heating it rapidly with carrier gas flowing in the opposite direction to that used during focusing. This fast secondary (trap) desorption 'injects' the analytes into the GC column in a narrow, concentrated band of vapour, compatible with capillary chromatography, and triggers the start of the GC program (*see* Fig 3).

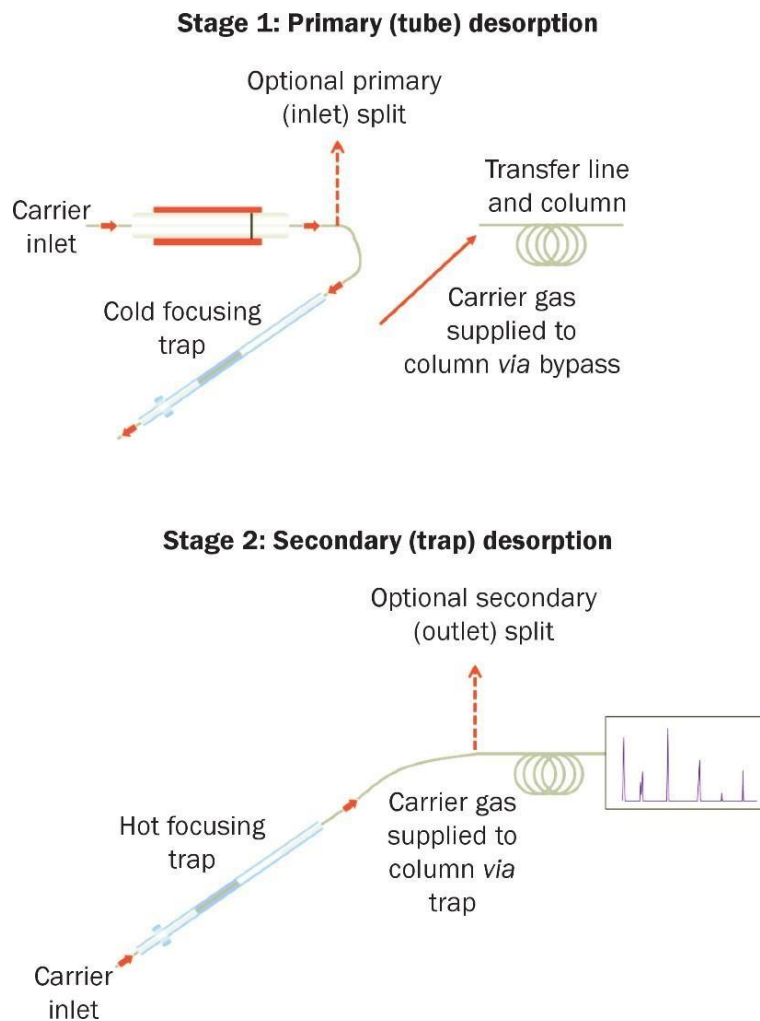

FIG. 3 SCHEMATIC; TWO MAIN STAGES OF THERMAL DESORPTION

NOTE — Reversing the direction of gas flow through the sorbent tube and focusing trap during primary and secondary desorption respectively, allows the use of multiple sorbents and thus extends the volatility range of compounds that can be sampled and analyzed in a single cycle.

7.13.2 Required features and functions of the thermal desorber:

- a) Leak-tight tube seals or 'analytical' caps to protect sampled and desorbed tubes from analyte loss and contaminant ingress while they are on the analytical system. This is particularly critical for automated operation where multiple tubes may be in situ for extended periods.
- b) Stringent leak testing of each tube after it is loaded into the sample flow path and before heat or gas flow is applied. Any tubes which fail the leak test should not be heated but retained intact for operator attention, while the system continues to analyze subsequent tubes in the sequence.

NOTE — As the carrier gas flow path of the chromatographic system is effectively broken into every time a new sample is uploaded for analysis, leak testing is essential for data confidence.

- c) Exclusion of artefacts from outer tube surfaces - The mechanism for sealing tubes into the sample flow path must exclude external contaminants, e.g. from handling tubes in the field.
- d) Pre-purging of air - Tubes shall be pre-purged with carrier gas (after leak testing and before desorption) to remove residual air, prevent sorbent and analyte oxidation and extend system life
- e) The secondary desorption process must allow quantitative splitting of the sample for compatibility with both trace ambient-level and higher workplace-level air contamination.

7.13.3 Other useful TD options include:

7.13.3.1 Cryogen-free (typically electrical) cooling of the focusing trap to controlled sub-zero temperatures to ensure the repeatable retention of very volatile compounds without liquid cryogen

7.13.3.2 Automatic addition of gas-phase internal standard onto a series of pre-conditioned tubes before field monitoring or onto the sampling end of the tube or focusing trap immediately before primary desorption. For analytical quality control best practice

7.13.3.3 Automatic dry purging of tubes (in the sampling direction) before primary desorption to selectively eliminate water and minimize analytical interference during analysis of humid samples.

7.13.3.4 Sample splitting during primary (tube) as well as secondary (trap) desorption to allow quantitative analysis of very high-level samples (e.g. industrial stack emissions) as well as trace level work

7.13.3.5 Quantitative re-collection of sample split flow for repeat analysis and validation of desorption efficiency and compound recovery (*see 3.2 and 8.1*).

8 PREPARING FOR FIELD MONITORING

8.1 Developing and Validating the Analytical Method

The approximate masses of each target analyte that will be collected during monitoring can be estimated from the expected air concentrations (or regulated limit levels) and pumped sample volumes (for more information *see Annex B*). Using conditioned tubes (*see 8.4*) prepare a number of mid-range standards containing these analyte levels (*see 6.4 and Annex C*).

NOTE — When monitoring uncharacterized atmospheres, the range and concentration of compounds present is unknown. In this case, it is recommended to collect and analyze some preliminary screening samples using broad spectrum tubes and a general purpose analytical method (*see Annex B*) for more guidance.

Ensure the mass spectrometer detector is tuned and performing according to manufacturer's specifications. Use the relevant list of compounds of interest (target compounds) or preliminary screening data to check the suitability of the analyzer configuration (choice of capillary GC column, focusing trap sorbents and settings, etc.) and choice of sorbents in the sampling tubes (*see 6.3*). Use the mid-range standards to develop and optimize the analytical method – GC program, mass spectrometer settings, TD temperatures and times, desorption flows, split ratios, etc. – and to confirm system stability.

The sensitivity and linearity of the analytical method can then be evaluated by running a multi-level calibration (*see 8.3*).

Desorption efficiency (i.e. the recovery of analytes from the sorbent tube and through the 2-stage TD process to the GC column) must be above 95 percent. This can be tested by re-running desorbed standard tubes to check there is no carryover and comparing the results obtained by thermal desorption with those obtained for a liquid injection of the same standard under the same GC conditions (temperature program, gas flow, split flow, etc). Alternatively, if the selected thermal desorber offers the option of quantitative re-collection of split flow; repeat analysis of the re-collected samples will quickly show if one or more compounds is not being fully recovered as it passes through the 2-stage TD process, relative to other stable compounds in the mix such as toluene. Parameters can then be amended accordingly.

NOTE — Most TD methods readily offer >99 percent recovery. If analyte loss occurs, possible causes include incomplete desorption, thermal degradation and condensation or sorption of compounds within the sample flow path.

8.2 Checking System and Sorbent Tube Blanks

Using a clean empty tube and the same analytical conditions that will be used for the samples, check the TD-GC-MS system blank meets method requirements (*see 8.4*). Repeat this exercise with representative blank sorbent tubes from the batch that will be used for field monitoring. These 'laboratory blank' tubes must contain the same combination of sorbents as the field monitoring tubes, have been conditioned at the same time and stored in the same container. Ideally they should also have been packed at the same time and had a similar history of use.

If the system or laboratory blank levels do not meet the method requirements condition the system and/or tubes using more stringent conditions (higher temperatures and faster gas flows) than will be used for analysis, but taking care not to exceed the maximum temperature of the least stable sorbent in the sample tubes.

The above blank analysis shall be repeated after reconditioning the tubes.

NOTE — Tubes may need repacking if they can no longer reach the required cleanliness after extensive conditioning.

8.3 Calibration

Prepare conditioned tubes (*see 8.4*) with standards of the target compounds (*see 6.4*) at 5 different levels (for more information *see Annex C*). The analyte masses introduced in each standard should cover the range expected to be collected during field monitoring with a factor of at least 20 between the analyte masses on the lowest and highest level standards.

A mid-range standard should be analysed at least every ten samples during routine operation and the results compared with the 3 previous mid-range standards to ensure system performance remains stable. A multi-level calibration, with replicates at each level, should be carried out whenever analysis of the single level standards shows system responses have drifted by 10 percent or more.

A multi-level calibration, with replicates at each level, should be run whenever the analytical method or target compound list is changed and immediately before analysis of a new batch of samples – ideally as part of the same analytical sequence.

Replicates for at least 4 of the 5 calibration levels, including the lowest and highest levels, should agree within 10 percent or the multi-level calibration exercise shall be repeated. The linear regression coefficient (R^2) should also be above 0.99 for toluene over the calibration range.

8.4 Sample Tube Conditioning

Newly-packed sorbent tubes should be obtained pre-conditioned from the manufacturer or be stringently conditioned on receipt in the laboratory, following manufacturer's instructions. Once sorbent tubes have been through the initial, lengthy conditioning process, they should remain sealed with long term storage caps (*see 7.3*), kept in a suitable clean storage container (*see 7.4*) and maintained at a controlled, stable temperature (ideally between 20 °C and 30 °C) at all times when not in use.

The total number of tubes required for a field monitoring exercise includes those for sampling, calibration, field blanks, lab blanks and back-up tubes.

If a batch of tubes has only just been desorbed and analyzed for a previous study (within 2 weeks) and if pollutant levels encountered during the previous study were low, and provided the tubes have been kept properly sealed and stored since their last use, they can be re-used for field monitoring without further conditioning. In all other cases the required batch of tubes should be conditioned within 2 weeks of the start of a field monitoring exercise by desorbing them for 10-15 minutes and at 100 ml/min inert (carrier) gas flow using slightly more stringent conditions (higher temperatures) than those required for analysis, but taking care not to exceed the safe maximum temperature of any sorbent in the tube.

In either case, a representative selection of the batch of tubes (at least 1 in 10) should be analyzed using routine analytical parameters (*see 8.1*), to ensure that the analytical blank is sufficiently small before tubes are sent to the field for air sampling. The blank level is acceptable if interfering peaks are at 10 percent or less of the areas of target compounds at the lowest level interest. If the blank is unacceptable, tubes should be reconditioned.

At least two of the conditioned tubes from each batch shall be retained sealed and stored in the laboratory throughout the field monitoring exercise. These are the laboratory blank tubes (*see 5.5*).

NOTE

- a) All sorbent tubes are subject to inherent artefacts the level of which will vary with sorbent type and desorption temperature. Follow manufacturer's guidance with respect to conditioning and analysis parameters to keep artefact levels to a minimum. It is normally possible to keep individual artefacts below 5 ng to 10 ng on conditioned Tenax tubes and around 2 ng on conditioned carbon tubes. It is also usually possible to chromatographically separate sorbent artefacts from low level compounds of interest such that the resultant analytical interference is not significant.
- b) Off-line multi-tube conditioning units are available and can increase analytical capacity by negating the need to condition sorbent tubes on the TD instrument.

8.5 Calibration of the Pump

Calibrate the pump (*see 7.8*) with 3 representative sorbent tubes (or tube assemblies) using an appropriate external calibrated meter. Check the measured pump flows agree within 5 percent across all 3 examples.

NOTE — As the process of pump calibration involves pulling air through sorbent tubes, these tubes cannot then be used for monitoring, blanks or calibration without further conditioning and blank checks. They should be set aside for the next tube conditioning operation.

9 SAMPLING

9.1 General Preparation for Sampling

Before monitoring begins, estimate the ideal sampling flow based on the monitoring period available, the safe sampling volume of the least well retained compound of interest, the expected concentration range, available analytical detection limits and required reporting limits.

NOTE

- a) Industry standard sorbent tubes, as described in 8.1 work optimally with flow rates between 10 and 200 ml/Min⁶, though there are exceptions for high boiling compounds and very short term tests (for more information *see* informative **Annex D**)
- b) Sampling efficiency will be 100 percent for compounds of interest provided safe sampling volumes (*see 3.7*) are not exceeded under field

monitoring conditions (temperature, humidity, etc. (*see* 7.1 and Annex A for more information).

9.2 Area Monitoring

Identify representative sampling locations that will not be impacted by exceptional localized pollution sources or ventilation conditions. Tubes should be protected from particulate ingress by orientating the open sampling end downwards. Tube and pump assemblies should also be protected from precipitation when monitoring outdoors, using simple, well-ventilated and non-emitting shelters.

9.3 Personal Exposure Assessment

When used for personal exposure assessment, the sorbent tube should be mounted vertically in the breathing zone of the wearer (e.g. on a collar or lapel), with the sampling end pointing down and unimpeded by clothing. The pump is attached to the belt or to some other appropriate support to minimize wearer inconvenience.

9.4 Sample Collection

9.4.1 Leave tubes capped and in the storage container until they have equilibrated with ambient conditions. Don't uncapped them until sampling is about to start. When the long-term storage caps are removed keep them in the tube storage container (*see* 7.4) throughout the monitoring exercise. Attach the pump to the non-sampling end of the tube, switch it on and set the required flow rate.

9.4.2 Recommended sampling conditions for workplace air are 10 ml/Min to 50 ml/Min for 8 h.

9.4.3 Recommended sampling conditions for indoor and ambient air are 20 ml/Min to 50 ml/Min for 24 h.

9.4.4 Recommended sampling conditions for material/product emission testing are 20 to 50 ml/Min for 2h.

9.4.5 For more information and guidance (*see* Annex D).

Note and record the unique identification number of the tube and the pump. Check and record the time, date and actual flow rate when the pump is turned on and again just before it is turned off at the end of the monitoring period.

9.4.6 At the end of sampling, disconnect the tube from the pump and seal it by carefully replacing and tightening the long-term storage caps (*see* 7.3) at each end of the tube using appropriate tools. Place the sealed and sampled tubes back into the storage and transportation container without delay. If the container of tubes is to be held under refrigerated conditions, ensure storage caps are retightened once tubes have equilibrated at their minimum storage temperature.

NOTE — Refrigerated storage is not usually necessary provided samples can be maintained at a stable temperature below 25 °C and analyzed within 4 weeks.

9.5 Quality Control during Sampling

9.5.1 Field Blanks

It should be prepared using tubes identical to those used for sampling and taken to the monitoring location. They should be subjected to the same handling procedure as the sample tubes except for the actual period of sampling. Record these as blanks and analyze them in the same sequence as the samples.

9.5.2 Replicate Samples

It should normally be collected using 2 pumped sample tubes in parallel at 10 percent of sampling locations. At least one replicate sample pair should be collected during each monitoring exercise. Replicate samples should be analyzed in the same sequence as the samples.

9.5.3 Back-up Tubes

As a check on breakthrough under field monitoring conditions, 10 percent of sampling locations should normally be monitored using two identical sorbent tubes connected together in series with appropriate unions (*see* 6.5). The sampling end of the secondary tube is connected to the non-sampling end of the primary sorbent tube.

10 DESORPTION AND ANALYSIS

10.1 Preparing for Analysis

Keep all the tubes associated with a monitoring exercise (sampled tubes and blanks) capped and inside the sealed storage / transportation container until ready for analysis. If tubes have been stored under refrigerated conditions, allow them to equilibrate with the laboratory temperature before removing the long-term storage caps or humidity might cause condensation inside the cool tubes causing analytical interference.

If an automated thermal desorber is in use, analytical caps should be placed on both ends of the tubes as soon as the long-term storage caps are removed (*see 7.12*) such that sorbent tubes are not left open-ended and exposed to lab air contamination for more than a few seconds. Place the capped tubes into the TD system ready for automatic operation. Alternatively, if using a single-tube desorber, only uncapped each tube immediately before it is sealed into the system for analysis.

Plan the analytical sequence (manual or automated) such that sample tubes are interspersed with calibrants (mid-range and multi-level as required), replicates, field blanks, lab blanks and back-up tubes.

10.2 Tube Analysis

Once uploaded and sealed into the TD flow path (manually or automatically as part of a multi-tube sequence), each sorbent tube should be subjected to a series of automatic checks and operations:

- a) While maintained at ambient temperature each tube should first be pressurized and subjected to a stringent, no-flow leak test.

NOTE

- i) Without such a test, a leak could go undetected, undermining confidence in data quality.
- ii) Any tubes which fail the leak test should not be analyzed but retained intact for user inspection and intervention to prevent sample loss.

- b) Air should then be purged from the tube to vent before heat is applied to avoid analyte and sorbent oxidation, artefact formation and degradation of the analytical system.

NOTE — It usually requires 10 x the volume of the tube (i.e. 20 ml to 30 ml) to completely displace the air in the tube, but larger volumes of carrier gas will be required to completely displace the air from tubes packed with strong sorbents such as carbon molecular sieves.

- c) If the selected thermal desorber offers automated dry purging of sample tubes to remove residual water, this step can be included here and takes place with inert carrier gas flowing through the tube in the sampling direction. Similarly, if the TD system offers the option of automated addition of gas-phase internal standard, it is usually introduced onto the sampling end of the tube or focusing trap at this point.

- d) The tube is then heated with carrier gas flowing (typically at 20 ml/Min to 100 ml/Min) in the opposite direction to the flow of air during sampling. Organic vapours are desorbed from the tube sorbents in this reverse flow of carrier gas and swept into the cold focusing trap where they are reconcentrated.

NOTE — Some TD systems allow sample splitting during tube desorption such that only a small proportion of the sample reaches the focusing trap. This facilitates analysis of very concentrated samples such as contaminated workplace air.

- e) Once primary (tube) desorption is complete, the focusing trap is heated rapidly (typically at 40 100 °C/s) in a reverse flow of carrier gas (typically 2 ml/min to 50 ml/min). This desorbs the organic vapours and transfers (injects) them into the GC column in a narrow, concentrated band of vapour, triggering the start of the GC run. Secondary (trap) desorption can be carried out split or splitless (*see Fig 4 to Fig 6*) for example chromatograms and Tables 2 to Table 4 for the conditions used for each.

- f) The respective response factors obtained during system calibration can then be applied to the measured peak areas to determine the masses of analytes in samples and blanks.

- g) Once analysis of each individual tube or sequence of tubes has been completed (manual or automated desorbers respectively), it (they) should be removed from the system, resealed with long-term storage caps (*see 7.3*) and replaced in the clean storage container (*see 7.4*). Tube desorption automatically cleans the sorbent tubes and leaves them ready for immediate re-use in many cases (*see 8.4* for more details.)

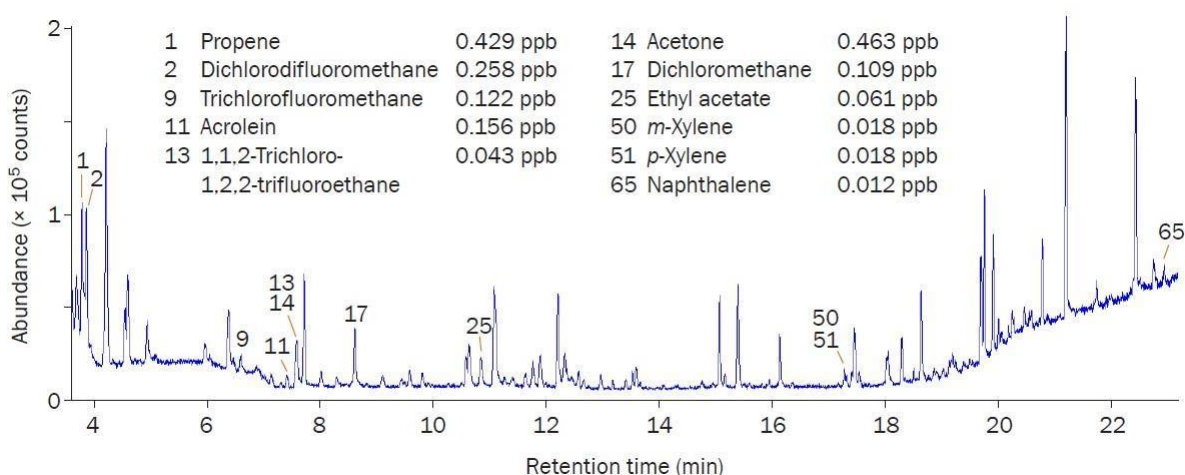

FIG. 4 EXAMPLE AIR SAMPLE ANALYSIS USING A PUMPED TUBE AND RUN USING THERMALDESORPTION GCMS.
NOTE THAT ALL IDENTIFIED PEAKS ARE AT OR BELOW LOW PPB- LEVELS

Table 2 – Instrument Parameters Used for Fig. 4
(Cause 9.2)

SI No.	Instrumentation – Figure 4		
(1)	(2)	(3)	(4)
i)	Sorbent tube	Universal Tube; 3.5 inch × 0.25 inch o.d (outside diameter)	Porous polymer/Graphitised carbon/Carbonised molecular sieve
ii)	Sampling pump	Capable of 20 ml/min to 500 ml/min in constant flow mode. Flow and volume recording, battery life 8 h	
iii)	Thermal desorber	Two stage system, capable of 'Re-collection', Peltier cooled backflush trap	
iv)	Gas Chromatograph	Single Split/Splitless Injector, running in constant flow when Thermal Desorber is interfaced.	
v)	Mass spectrometer	Single Quadrupole	

Sl No.	Instrument parameters _ Thermal desorber		
(1)	(2)	(3)	(4)
i)	Focusing trap	Capable of collecting 'Air Toxics'	Porous polymer/Graphitised carbon/Carbonised molecular sieve
ii)	Flow path temperature	120 °C	
iii)	Tube dry purge	50 ml/min	6 min
iv)	Tube desorb	250 °C	5 min
v)	Trap low temperature	25 °C	
vi)	Trap desorb	300 °C	3 min
	Outlet split	10 ml/Min	

Sl. No	Instrument parameters _ Gas Chromatograph		
(1)	(2)	(3)	(4)
i)	Carrier gas	Helium	
ii)	Column	624 phase	60 m × 0.25 mm × 1.4 µm
iii)	Column flow	1.5 ml/Min	Constant flow mode
iv)	Oven ramp	35°C (5 min), 10°C/Min to 160°C, 25 °C/Min to 230 °C min)	
v)	Inlet temperature	200 °C	

Sl. No	Instrument parameters – Mass spectrometer		
(1)	(2)	(3)	(4)
i)	MS source temperature	300 °C	
ii)	MS quad temperature	200 °C	
iii)	MSD transfer line temperature	240 °C	
iv)	Data acquisition mode	Full scan	m/z 35 - 300

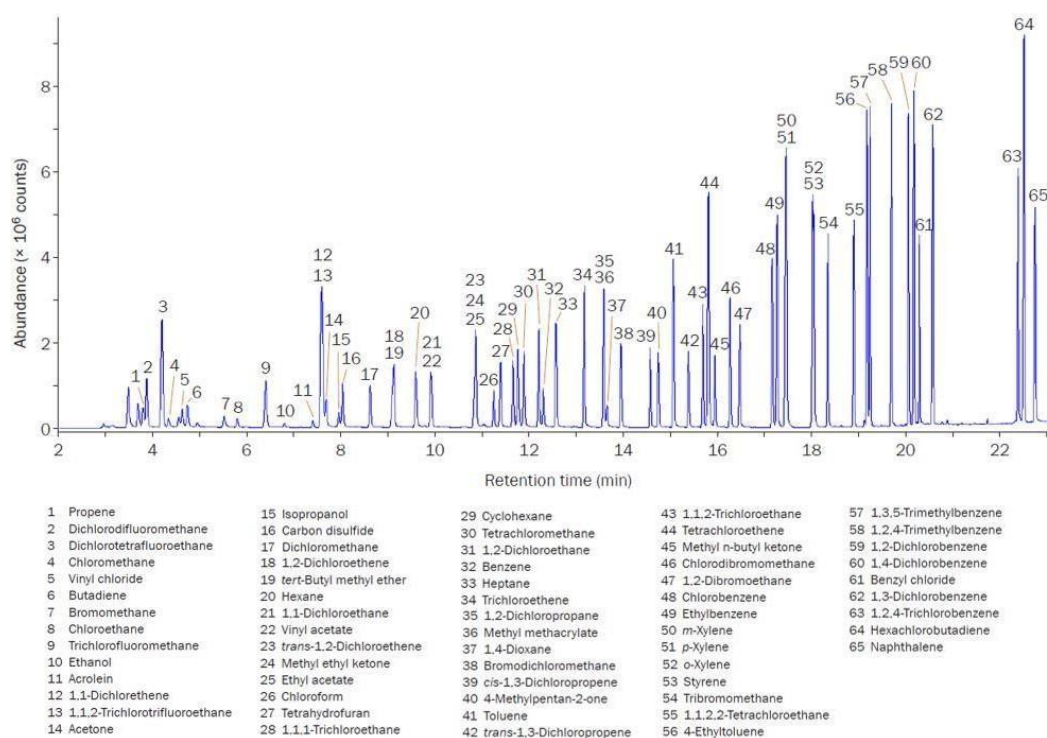

FIG. 5 EXAMPLE OF A 65 COMPONENT AIR TOXICS STANDARD FOR AMBIENT OR INDOOR AIR ANALYSIS.

Table 3 – Instrument Parameters used for Fig. 5
(Clause 9.2)

Sl. No	Instrumentation – Figure 5		
(1)	(2)	(3)	(4)
i)	Sorbent tube	Universal Tube; 3.5 inch × 0.25 inch o.d. (outside diameter)	Porous polymer/Graphitised carbon/Carbonised molecular sieve
ii)	Thermal desorber	Two stage system, capable of ‘Re-collection’, with Peltier cooled backflush trap	
iii)	Gas Chromatograph	Single Split/Splitless Injector, running in constant flow when Thermal Desorber is interfaced.	
iv)	Mass spectrometer	Single Quadrupole	

Sl. No	Instrument parameters – Thermal desorber		
(1)	(2)	(3)	(4)
i)	Focusing trap	Capable of collecting ‘Air Toxics’	Porous polymer/Graphitised carbon/Carbonised molecular sieve
ii)	Flowpath temperature	120 °C	
iii)	Tube dry purge	50ml/Min	6 min
iv)	Tube desorb	250 °C	5 min
v)	Trap low temperature	25 °C	

vi)	Trap desorb	300 °C	3 min
vii)	Outlet split	10 ml/Min	

Sl. No	Instrument parameters – Gas Chromatograph		
(1)	(2)	(3)	(4)
i)	Carrier gas	Helium	
ii)	Column	624 phase	60 m × 0.25 mm × 1.4 μm
iii)	Column flow	1.5 ml/Min	Constant flow mode
iv)	Oven ramp	35°C (5 min), 10°C/Min to 160°C, 25°C/Min to 230°C (3 min)	
v)	Inlet temperature	200 °C	

Sl. No	Instrument parameters – Mass spectrometer		
(1)	(2)	(3)	(4)
i)	MS source temperature	300 °C	
ii)	MS quad temperature	200 °C	
iii)	CMSD transfer line temperature	240 °C	
iv)	Data acquisition mode	Full scan	m/z 35 - 300

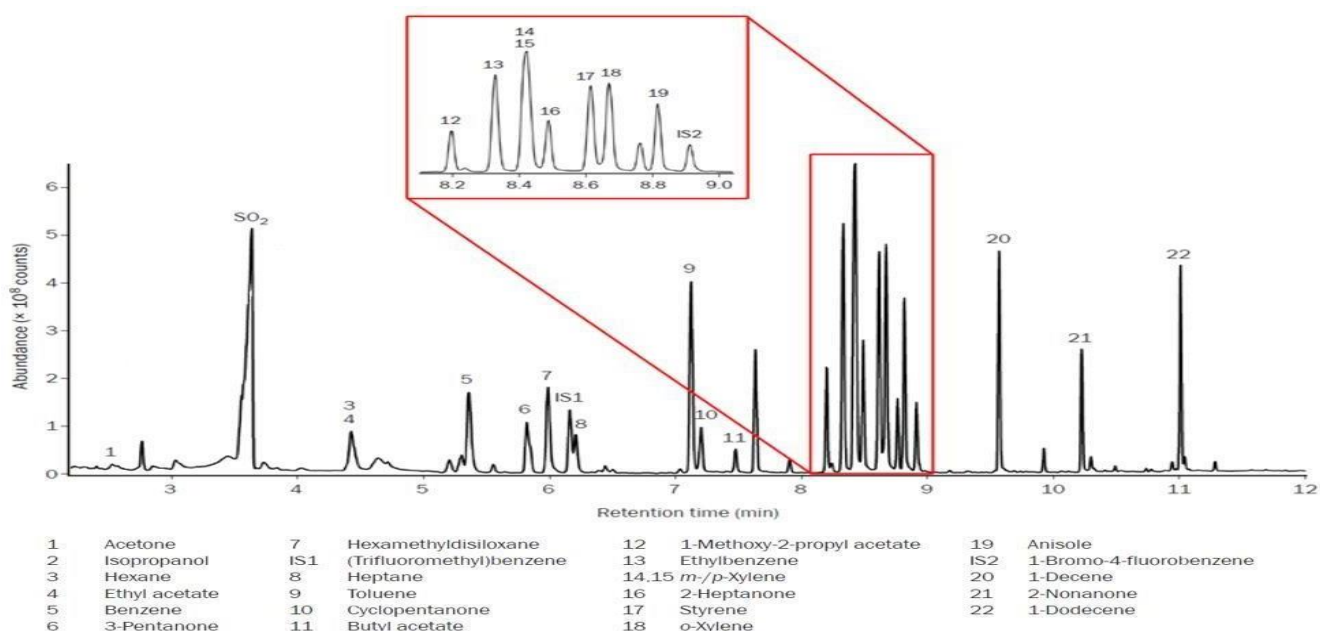

FIG. 6 EXAMPLE INDUSTRIAL AIR MONITORING STANDARD. TWO FLUORINATED AROMATIC COMPOUNDS ARE USED AS INTERNAL STANDARDS (IS 1 & IS 2)

Table 4 Instrument Parameters used for Fig. 6

(Clause 9.2)

Sl. No	Instrumentation _ Figure 6		
(1)	(2)	(3)	(4)
i)	Sorbent tube	Universal Tube; 3.5 inch × 0.25 inch o.d. (outside Carbonised molecular diameter	Porous polymer/ Graphitised carbon/) sieve
ii)	Thermal desorber	Two stage system, capable of 'Re-collection', with Peltier cooled backflush trap	
iii)	Gas Chromatograph	Single Split/Splitless Injector, running in constant flow when Thermal Desorber is interfaced.	
iv)	Mass spectrometer	Single Quadrupole	

Sl. No	Instrument parameters _ Thermal desorber		
(1)	(2)	(3)	(4)
	Focusing trap	Capable of collecting 'Air Toxics'	Porous polymer/Graphitised carbon/Carbonised molecular sieve
	Flowpath temperature	120 °C	
	Tube dry purge	60 ml/Min	1 min
	Tube desorb	300 °C	5 min
	Trap low temperature	25 °C	
	Trap desorb	250 °C	3 min
	Outlet split	10 ml/Min	

Sl. No	Instrument parameters _ Gas Chromatograph		
(1)	(2)	(3)	(4)
i)	Carrier gas	Helium	
ii)	Column	100 percent methyl siloxane	30 m × 0.25 mm × 1.0 µm
iii)	Column flow	1.5 ml/Min	Constant flow mode
iv)	Oven ramp	35°C (3 min), 15 °C/Min to 85°C (0 min), 25°C/Min to 220 °C (1 min)	

Sl. No	Instrument parameters – Mass spectrometer		
(1)	(2)	(3)	(4)
i)	MS source	250 °C	
ii)	MSD transfer line temperature	230 °C	
iii)	Data acquisition mode	Full scan	m/z 36-180 (0-22 min), m/z 33-270 (2.2 +min)

11 Calculations

The concentration of each analyte in the sampled air, C_m , can then be calculated in ng/l as follows:

$$C_m = \frac{M_s - M_b}{v}$$

where,

M_s = is the mass of analyte measured on the sample tube in nanograms

M_b = is the mass of that analyte detected on the field blank in nanograms, and;

V = is the volume of air sample in litres ng/l concentrations can readily be converted to ppm or ppb terms using the relevant molecular weight (*see* Annex B) for more information on this relationship

Example calculation

An ambient air sample has been taken over a 24 h period at 50 ml/Min. This is a total volume of 72 l. Hexane was detected on the sample tube at 360 ng and was not detected in the field blank (0 ng).

$$C_m = (360 \text{ ng} - 0 \text{ ng}) / 72 \text{ l}$$

$$C_m = 5 \text{ ng/l or } 5 \text{ } \mu\text{g/m}^3 \text{ (approximately 1.43ppb)}$$

12 QUALITY CONTROL

The following quality control criteria shall be met:

- The desorption efficiency shall be > 95 percent (> 99 percent should be readily achievable) (*see* 8.1)
- The linear regression co-efficient shall be above 0.99 for toluene across the calibration range (*see* 8.3)
- The chromatographic system and method must be capable of detecting target compounds at the lowest levels of interest with a signal-to-noise ratio of at least 5 to 1, preferably 10 to 1.
- The blank level is acceptable if interfering peaks are below 10 percent of the areas of target compounds at the lowest level interest (*see* 8.4).
- If field blank chromatograms reflect the same profile of organics as on the sample tubes, and if the levels of these components are 5 percent or more of the sampled compounds, this must be noted in the final report (*see* 13). If levels are 10 percent or more of those on sampled tubes, the sampled tube data are invalid.
- If the level of one or more analytes is detected on the back up tube (*see* 9.6.3) at > 10 percent of the sampled tube

levels, the data for affected compounds are invalid.

- g) Replicate mid-level standards (*see 9.3*) should agree within 10 percent
- h) Replicate samples (*see 9.6.2*) should agree within 15 percent for > 80 percent of reported analytes
NOTE — Replicate samples provide a measure of the precision achievable for the entire monitoring procedure including the sampling and analysis.
- j) The pump flow rate shall be stable to within ± 5 percent and the total volume of air sampled by the pump over the sampling period shall be within ± 10 percent of the calculated volume. A pump conforming to ISO EN 13137 or equivalent may be expected to be within these limits.

13 TEST REPORT

The laboratory test reports should contain the details specified for the respective monitoring campaign. The sort of information which may be required includes:

- a) Details of the sampling tube (unique identification number, sorbents, etc.), pump identification number, analytical system used and associated data file identification;
- b) Chain of custody information (e.g. details of who collected the samples and who ran the analysis)
- c) Reference to this standard and any supplementary standards referenced
- d) The sampling location, sampling time period, pump flow rate at the beginning of sampling, pump flow rate at the end of sampling and the volume of air sampled
- e) The test results for each sample, including target compounds (calibrated using reference compounds) and any unknowns present in significant concentrations (> 5 percent of the total peak area) calibrated using the response factor for toluene.

NOTE — When reporting results for locations that were monitored using replicate samples, the mean result should be reported for all analytes that agree within 15 percent (*see 11*) and the higher result for all other analytes. (*see below*).

- f) Other relevant test results – including:
 - 1) The most recent multi-level calibration (report and example chromatogram from the lowest level standard),
 - 2) Any mid-range, single-level standards analyzed during the sample sequence (reports and chromatograms)
 - 3) Any field and/or laboratory blank tubes analyzed during the sample sequence (reports and chromatograms)
 - 4) Any back-up tubes analyzed during the sample sequence (reports and chromatograms)
- g) Identify any monitoring locations where replicate samples were collected and where most of the measured target compound concentrations differ by more than 15 percent
NOTE — In this situation, results from the whole study should be regarded as semi-quantitative unless there is evidence to the contrary (e.g. several other replicate samples collected in the same study which agree within 15 percent).
- h) Any unusual features noted during sample collection or analysis
- j) Any operation not included in this standard.

ANNEX A

(Clause 1, Clause 8.1.1.8, Clause 9.1)

EXAMPLE RETENTION VOLUME (RV) AND SAFE SAMPLING VOLUME (SSV) DATA FOR TARGET COMPOUNDS COMPATIBLE WITH THIS METHOD.

RELATES TO INDUSTRY STANDARD TUBES AT 20 °C PACKED WITH THE SORBENTS SPECIFIED

Sources used in this Annex are denoted by the superscript (ANIV) and are listed at the bottom of the table.

Sl. No.	Compound name	B.pt (°C)	Sorbent & mass (in ind. std stst tubes)	RV (l)	SSV	Sources (ANIV)
(1)	(2)	(3)	(4)	(5)	(6)	(7)
i)	Aliphatic hydrocarbons					
	Propane	42	Carboxen 569 500 mg	7.2	3.6	2
	1,3-butadiene	-4	Carbopack X	>25	>17	4
			Carbograph 5TD	10	7	4
	Butane	-0.5	Sulficarb 300 mg (Formerly Spherocarb)	1 600	800	2, 3
	Pentane	35	Sulficarb 300 mg	63 000	30 000	2, 3
	Hexane	69	Tenax TA 200 mg	6.4	3.2	1, 2, 3
			Sulficarb 300 mg	3 900	2 000	2, 3
	Heptane	98	Tenax TA 200 mg	34	17	1, 2, 3
	Octane	125	Tenax TA 200 mg	160	80	1, 2, 3
	Nonane	151	Tenax TA 200 mg	1 400	700	1, 2, 3
	Decane	174	Tenax TA 200 mg	4 200	2 100	1, 2, 3
	Undecane	196	Tenax TA 200 mg	25 000	12 000	1, 2, 3
	Dodecane	216	Tenax TA 200 mg	126 000	63 000	1, 2, 3
ii)	Aromatic hydrocarbons					
	Benzene	80	Tenax TA 200 mg	13	6.2	1, 2, 3
			Sulficarb 300 mg	1000 000	500 000	2, 3
			Carbopack X	3 240	1 620	2
	Toluene	111	Tenax TA 200 mg	76	38	1, 2, 3
	Xylene	138 - 144	Tenax TA 200 mg	600	300	1, 2, 3
	Ethylbenzene	136	Tenax TA 200 mg	360	180	1, 2, 3
	Propylbenzene	159	Tenax TA 200 mg	1 700	850	1, 2, 3
	Isopropylbenzene	152	Tenax TA 200 mg	960	480	1, 2, 3
	Ethyltoluene	162	Tenax TA 200 mg	2 000	1 000	1, 2, 3
	Trimethylbenzene	165 - 176	Tenax TA 200 mg	3 600	1 800	1, 2, 3
	Styrene	145	Tenax TA 200 mg	600	300	1, 2, 3
	Methylstyrene	167	Tenax TA 200 mg	2 400	1 200	1, 2, 3
iii)	Halocarbons					

	Dichloromethane	40	Sulficarb 300 mg	400	200	2, 3
	Carbon tetrachloride	76	Tenax TA 200 mg	12	6.2	1, 2, 3
	1,2-Dichloroethane	84	Tenax TA 200 mg	11	5.4	1, 2, 3
	1,1,1-Trichloroethane	74	Sulficarb 300 mg	18 000	9 000	2, 3
	1,1,2-Trichloroethane	114	Tenax TA 200 mg	68	34	1, 2, 3
	1,1,2,2-Tetrachloroethane	146	Tenax TA 200 mg	340	170	1, 2, 3
	Trichloroethylene	87	Tenax TA 200 mg	11.2	5.6	1, 2, 3
	Tetrachloroethylene	121	Tenax TA 200 mg	96	48	1, 2, 3
	Chlorobenzene	131	Tenax TA 200 mg	52	26	1, 2, 3
iv)	Esters, glycol esters and glycol ethers					
	Ethyl acetate	71	Tenax TA 200 mg	7.2	3.6	1, 2, 3
	Propyl acetate	102	Tenax TA 200 mg	36	18	1, 2, 3
	Isopropyl acetate	90	Tenax TA 200 mg	12	6	1, 2, 3
	Butyl acetate	126	Tenax TA 200 mg	170	85	1, 2, 3
	Isobutyl acetate	115	Tenax TA 200 mg	265	130	1, 2, 3
	Methyl acrylate	81	Tenax TA 200 mg	1 348	6 524	1, 2, 3
	Ethyl acrylate	100	Tenax TA 200 mg	4 855	2 427	1, 2, 3
	Methyl methacrylate	100	Tenax TA 200 mg	556	273	1, 2, 3
	Methoxyethyl acetate	145	Tenax TA 200 mg	1 630	815	1, 2, 3
	Ethoxyethyl acetate	156	Tenax TA 200 mg	30 300	15 150	1, 2, 3
	Butoxyethyl acetate	192	Tenax TA 200 mg	30 013	1 506.5	1, 2, 3
	Methoxyethanol	125	Tenax TA 200 mg	610	35	1, 2, 3
	Ethoxyethanol	136	Tenax TA 200 mg	1 070	535	1, 2, 3
	Butoxyethanol	170	Tenax TA 200 mg	7 027	3 513	1, 2, 3
	Methoxypropanol	118	Tenax TA 200 mg	2 716	138	1, 2, 3
v)	Alcohols					
	Methanol	65	Sulficarb 300 mg	1 260	630	2, 3
			Carboxen 569 500mg	4	2	2
	Ethanol	78	Sulficarb 300 mg	6 900	3 500	2, 3
	<i>n</i> -Butanol	118	Tenax TA 200 mg	10	5	1, 2, 3
	Isobutanol	108	Tenax TA 200 mg	5.6	2,8	1, 2, 3

	Octanol	180	Tenax TA 200 mg	2 800	1 400	1, 2, 3
	Phenol	182	Tenax TA 200 mg	480	240	1, 2, 3
vi)	Aldehydes and ketones					
	Furfural	162	Tenax TA 200 mg	600	300	1, 2, 3
	2-Butanone (methyl ethyl ketone)	80	Tenax TA 200 mg	6.4	3.2	1, 2, 3
	Methyl isobutyl ketone	118	Tenax TA 200 mg	52	26	1, 2, 3
	Cyclohexanone	155	Tenax TA 200 mg	340	170	1, 2, 3
	3,5,5-Trimethyl-cyclohex-2-enone	214	Tenax TA 200 mg	11 000	5 600	1, 2, 3
vii)	Other					
	Pyridine	116	Tenax TA 200 mg	80	40	1, 2, 3
	Aniline	184	Tenax TA 200 mg	440	220	1, 2, 3
	Nitrobenzene	211	Tenax TA 200 mg	28 000	14 000	1, 2, 3
	Ethylene oxide	11	Carboxen 569 500mg	140	70	2
viii)	Sources:					
	1^{A IV} - ISO 16000-6					
	2^{A IV} - ASTM D6196					
	3^{A IV} - ISO 16017-1					
	4^{A IV} - Application note 20, Markes International Ltd					

ANNEX B

(Clause 4)

COMPARING THERMAL DESORPTION (TD) WITH SOLVENT EXTRACTION (SE) FOR AIR MONITORING: A SUMMARY

B-1 SENSITIVITY

Solvent extraction typically involves 1-2 µl GC injections of 1-2 ml solvent extracts taken from the charcoal tubes. In contrast, TD enables 100 percent transfer of collected compounds to the GC column. This factor alone means TD is 1 000 times more sensitive – compatible with ppb and sub-ppb detection limits as well as higher level samples.

B-2 DESORPTION/EXTRACTION EFFICIENCY

National and international standard methods specifying thermal desorption (*see 4*), including this standard, require at least 95 percent desorption efficiency from the sorbent sampling tube and, in practice, complete extraction/desorption and transfer of target analytes to the GC in a single desorption cycle is invariably straightforward. This is because TD is a dynamic process, with gas continually purging compounds away from the sorbent or sample matrix as soon as they are released into the vapour phase by the rising temperature. In contrast, typical solvent extraction procedures are static, with analytes partitioning, in equilibrium, between the sorbent, solvent and vapour (headspace) phases. Standard solvent extraction methods therefore typically require only 75 percent recovery and even this can be challenging to achieve reliably in practice (*see A-3*).

B-3 DESORPTION/EXTRACTION REPEATABILITY

Desorption efficiencies have been reported to drop below 30 percent when charcoal tubes and CS₂ extraction are used for polar compounds in humid air⁸. This compromises repeatability and can lead to significant under-reporting, as the analyst may not be aware of field/sample conditions.

B-3.1 Exposure Risk

The solvent most commonly used for charcoal tube extraction is CS₂. CS₂ is toxic, odorous and presents a potential health and safety hazard to laboratory staff. Thermal desorption procedures often require the preparation of a liquid standard for calibration, but no hazardous extraction solvent.

B-3.2 Costs

Cost should only be taken into consideration if both methods work equally well for the given air monitoring application. However, as a general rule, thermal desorption costs less per sample unless operation is infrequent, in which case solvent extraction is more cost effective.

The initial investment required for TD operation is typically higher than that for solvent extraction, even allowing for installation of a solvent fume hood in the laboratory to extract CS₂. TD tubes are also more expensive than charcoal tubes, but as they are re-usable (typically at least 100 or 200 times) the cost per sample is much lower than one-use charcoal tubes. TD can also be fully automated, reducing errors and cost relative to labour-intensive solvent extraction.

B-3.3 Analytical Interference

One of the reasons CS₂ was originally selected as a preferred solvent for charcoal-based air sampling methods is that it gives little or no signal on a GC flame ionization detector (FID). However, this advantage does not hold for GC-MS detection. Common solvent interference concerns include masking of peaks of interest, signal quenching (for components co-eluting with the solvent) and baseline disturbances. All these make peak integration difficult and more prone to error. TD is inherently free from solvent and other chromatographic interference – see also point below.

B-3.4 Selective Elimination of Interferents

Depending on the sorbent and compounds of interest, TD procedures can generally be optimized to selectively purge air, water and other volatile interferences while target species are retained and enriched/concentrated. This is rarely possible for charcoal tube and CS₂ extraction methods.

B-3.5 Repeat Analysis

Historically, the main advantage of solvent extraction vs TD methods was that each liquid extract could be analyzed several times whereas thermal desorption was a one-shot technique. However, most TD systems now offer quantitative re-collection of samples for repeat analysis, meaning the one-shot limitation no longer applies.

B-3.6 Versatility

TD sorbent tubes can be used for pumped sampling or in axial diffusive (passive) mode.

ANNEX C

(Clause 6.4, Table 1, Clause 6.4.4, Clause 8.1, Clause 8.3, Clause 11)

GUIDANCE ON ESTIMATING THE MASS OF ANALYTE THAT WILL BE COLLECTED ON A SORBENT TUBE DURING PUMPED AIR MONITORING AND ASSOCIATED CALCULATION OF THE RESPECTIVE GAS OR LIQUID STANDARD AMOUNTS NEEDED FOR CALIBRATION

C-1 ESTIMATING THE MASS OF ANALYTE (X) THAT WILL BE COLLECTED DURING AIR MONITORING (CHARACTERISED ATMOSPHERES)

When estimating the masses of each analyte expected to be collected during field monitoring, it is simplest to go back to first principles and apply the gas laws as follows: A mole of pure vapour occupies ~25 l at room temperature and pressure

For a nominal compound \times with molecular weight 100, this means that a mole (100 g) of pure \times vapour occupies ~25 l at room temperature and pressure.

Therefore 10 l of pure \times vapour would contain around 40 g of \times

Therefore sampling 10 l of air with \times at 1 ppm would lead to collection of ~40 μg of \times And sampling 100 l of air with \times at 1 ppm would lead to collection of ~400 μg of \times And sampling 10 l of air with \times at 1 ppb would lead to collection of ~40 ng of \times

And sampling 1 l of air with X at 1 ppb would lead to collection of ~4 ng of \times And sampling 50 l of air with \times at 100 ppt would lead to collection of ~20 ng of \times

By applying the actual molecular weights of target compounds, expected air concentrations (or regulated limit levels if known) and proposed air sampling volumes, this approach can be used to estimate the range of masses that will be collected during any field monitoring exercise.

C-2 ESTIMATING THE RANGE AND MASSES OF INDIVIDUAL ANALYTES THAT WILL BE COLLECTED FROM UNCHARACTERISED ATMOSPHERES

When monitoring uncharacterized atmospheres, it is helpful to first collect screening samples at the monitoring location. Screening samples are typically collected using broad-spectrum tubes (*see 6.2.4*) to collect air samples in parallel at two different rates – e.g. at 20 ml/Min and 100 ml/Min for 2 h, leading to the collection of 2.4 l and 12 l samples. All the screening samples are subsequently analyzed using TDGCMS and quantified approximately using the response factor for toluene. This allows the range of compounds present to be identified and the collected mass of each to be estimated before finalizing sampling and analytical parameters.

In the example described, a peak-by-peak comparison of the results from the 12 and 2.4 l samples should show area ratios of 5:1. Any significant deviation from this should alert the user to potential issues – e.g. interferences, artefacts or analyte breakthrough during sampling.

NOTE — If the thermal desorption apparatus offers the option of quantitative sample re-collection, it is recommended to first analyze the uncharacterized samples using a high split ratio and apply sample recollection. The high split ratio prevents any risk of contaminating the analytical system with unexpectedly high concentration compounds. A lower split ratio can then be used to analyze the re-collected samples, if required, to measure any particularly toxic or odorous compounds that are significant at trace levels.

C-3 CALCULATING THE CONCENTRATION OF GAS OR LIQUID STANDARD NEEDED FOR CALIBRATION

Once the identities and expected masses of compounds of interest have been estimated (*see B-1 and B-2*) for each air monitoring study the amounts of gas or liquid standard required can be calculated as shown in the following examples:

C-3.1 An Example for Workplace Air Monitoring

As explained above; monitoring an atmosphere containing 0.5 ppm of compound \times at 20 ml/Min for 8 h would lead to the sampling of nearly 10 l (*see 9.6.1*) of air and the collection of ~20 μg of \times .

If liquid standards are being used (*see 6.4.3*); this would mean that the mid-range calibration standard tube would need to contain 20 μg of X. The mid-range liquid standard would therefore need to contain ~2 percent of \times by volume such that such that a 1 μl (~1 mg) injection introduced 20 μg of \times into a conditioned sorbent tube (6.4.4). In this example, the respective highest-level liquid standard could be 10 percent \times by volume such that a 1 μl (~1 mg) injection introduced 100 μg of X into the conditioned sorbent tube. The lowest level liquid standard could be 0.5 percent X by volume such that a 1 μl (~1 mg) injection introduced 5 μg of X into a conditioned sorbent tube.

Alternatively, a gas standard for this application might contain X at 100 ppm. In this example, the gas standard is 200 times more concentrated than the expected workplace atmosphere. Loading 50 ml of 100 ppm gas standard into a clean sorbent tube (see 6.4.2) will therefore introduce the same mass of X as sampling 10 l of air with X at 0.5 ppm. Introducing 50 ml of the gas standard onto a conditioned tube would generate the mid-level standard. In this example, the respective highest level calibration standard could be generated by introducing 250 ml of the 100 ppm gas standard into a clean sorbent tube and the lowest level standard by introducing 10 ml of the 100 ppm gas standard into a clean sorbent tube.

C-3.2 An Example for Ambient or Indoor Air Monitoring

As explained above; monitoring an atmosphere containing 2 ppb of compound \times at 50 ml/Min for 24 h would lead to the sampling of 72 l of air and the collection of ~580 ng of \times .

If liquid standards are being used (6.4.3); this would mean that the mid-range calibration standard tube would need to contain ~580 ng of X. The mid-range liquid standard would therefore need to contain ~0.06 percent of \times by volume such that a 1 μ l (~1 mg) injection introduced ~580 ng of \times into a conditioned sorbent tube (6.4.4). In this example, the respective highest-level liquid standard could be 0.3 percent X by volume such that a 1 μ l (~1 mg) injection introduced 3 μ g of X into the conditioned sorbent tube. The lowest level liquid standard could be 0.015 percent X by volume such that a 1 μ l (~1 mg) injection introduced ~150 ng of \times into a conditioned sorbent tube.

Alternatively, a gas standard for this application might contain X at 100 ppm. In this example, the gas standard is 50 000 times more concentrated than the expected ambient or indoor atmosphere. Loading 1.5 ml of 100 ppm gas standard into a clean sorbent tube (see 6.4.2) will therefore introduce roughly the same mass of X as sampling 72 l of air with X at 2 ppb. Introducing 1.5 ml of the gas standard onto a conditioned tube would generate the mid-level standard. In this example, the respective highest level calibration standard could be generated by introducing 10 ml of the 100 ppm gas standard into a clean sorbent tube and the lowest level standard by introducing 0.5 ml of the 100 ppm gas standard into a clean sorbent tube.

C-3.3 An Example for Material Emissions Testing

As explained above; monitoring an atmosphere containing 5 ppb of compound \times at 50 ml/Min for 2 h would lead to the sampling of 6 l of air and the collection of ~120 ng of \times .

If liquid standards are being used (see 6.4.3) this would mean that the mid-range calibration standard tube would need to contain 120 ng of \times . The mid-range liquid standard would therefore need to contain ~0.012 percent of \times by volume such that a 1 μ l (~1 mg) injection introduced 120 ng of \times into a conditioned sorbent tube (see 6.4.4). In this example, the respective highest-level liquid standard could be 0.06 percent \times by volume such that a 1 μ l (~1 mg) injection introduced 600 ng of \times into the conditioned

sorbent tube. The lowest level liquid standard could be 0.003 percent \times by volume such that a 1 μ l (~1 mg) injection introduced 30 ng of \times into a conditioned sorbent tube.

Alternatively, a gas standard for this application might contain X at 10 ppm. In this example, the gas standard is 2 000 times more concentrated than the expected material emissions chamber exhaust. Loading 3 ml of 10 ppm gas standard into a clean sorbent tube (see 7.4.2) will therefore introduce the same mass of X as sampling 6 l of air with X at 5 ppb. Introducing 3 ml of the gas standard onto a conditioned tube would generate the mid-level standard. In this example, the respective highest level calibration standard could be generated by introducing 15 ml of the 10 ppm gas standard into a clean sorbent tube and the lowest level standard by introducing 0.75 ml of the 10 ppm gas standard into a clean sorbent tube.

ANNEX D

(Clause 9.1, Clause 9.4.5)

EXAMPLE SAMPLE VOLUMES FOR A RANGE OF TYPICAL AIR MONITORING APPLICATIONS

D-1 Sampling volumes vary significantly depending on the specific air application and associated monitoring criteria – duration of operation, target compound list, required reporting period, expected concentration levels, etc. Industry standard sorbent tubes, as described in 8.1 work optimally with flow rates between 10 and 200 ml/Min⁶, or up to 500 ml/Min for two very specific scenarios:

- a) short term (15 minute) monitoring
- b) long term sampling of very high-boiling vapours (volatility below n-C26).

D-2 At the slow end, flow rates are limited by interference from diffusive ingress which typically occurs at rates up to 0.5 ml/Min in standard stainless steel tubes. At the high end, flow rates are limited by chromatographic effects and the ‘numbers of theoretical plates’.

NOTE — Analyte breakthrough and retention volumes are predominantly controlled by chromatographic effects and are normally independent of vapour concentration or the mass of compound collected, just as the retention time of a compound will remain constant under a given set of GC conditions independent of peak size. Breakthrough during sampling is therefore rarely affected by compound concentration or sorbent saturation, until levels get extremely high (>1 mg retained or > 100 ppm) causing tube overload.

D-3 Taking the above into consideration, example sampling volumes for a range of air monitoring applications include:

D-3.1 1 l air samples – e.g. for ultra-volatile species like freons in urban air o E.g. 25 ml/Min for 40 min

D-3.2 14.4 l air samples for BTEX in ambient or indoor air o E.g. 10 ml/Min for 24 h – to determine the time weighted average level over a whole 24 h period

D-3.3 48 l air samples for monitoring personal exposure to trace levels of a highly toxic chemical in the workplace o E.g. 100 ml/Min over an 8 h shift

D-3.4 ~500 l air samples for measuring very low concentration vapours of toxic semi-volatiles such as PAH and phthalates in ambient and indoor air⁹ o E.g. 350 ml/Min for 24 h

BIBLIOGRAPHY

RELEVANT STANDARD METHODS

- The following national and international standard methods provide useful background information:
- **US EPA Method TO-17:** Determination of volatile organic compounds in ambient air using active sampling onto sorbent tubes.
- **ISO 16017-1:** Indoor, ambient and workplace air - Sampling and analysis of volatile organic compounds by sorbent tube/thermal desorption/capillary gas chromatography. Part 1: Pumped sampling
- **ISO 16000-6:** Indoor Air. Part 6: Determination of organic compounds (VVOCs, VOCs and SVOCs) in indoor and test chamber air by active sampling on sorbent tubes, thermal desorption and gas chromatography using MS or MS/FID.
- **EN 14662-1:** Ambient air quality – Standard method for the measurement of benzene concentrations. Part 1: Pumped sampling followed by thermal desorption and gas chromatography method.
- **CEN TS 13469:** Stationary source emissions — Determination of the mass concentration of individual gaseous organic compounds — Sorptive sampling method followed by solvent extraction or thermal desorption.
- **ASTM D6196:** Standard practice for choosing sorbents, sampling parameters and thermal desorption analytical conditions for monitoring volatile organic chemicals in air