

भारतीय मानक मसौदा
रिफिल, बॉल प्वाइंट पेन — विशिष्टि
(IS 3707 का तीसरा पुनरीक्षण)

Draft Indian Standard
Refill, Ball Point Pen — Specification
(Third Revision of IS 3707)

(Not to be reproduced without the permission of BIS or used as an Indian Standard)

ICS 87.080

Printing Inks, Stationery and Allied Products Sectional
Committee, CHD 14

Last date of comments: 08.07.2024

Printing Inks, Stationery and Allied Products Sectional Committee, CHD 14

FOREWORD

(Formal clauses will be added later)

This standard was first published in 1966 and subsequently revised in 1980 and 1984. In the second revision, balls of smaller diameter with alternate material of construction were added. The requirement of length of writing was modified according to the diameter of the ball and the test method was simplified to make it more practical and suitable to the manufacturers.

In this revision, Reference clause has been incorporated. Also, Packing and Marking clause has been updated. Now, the standard has been updated based on the technological advancements that may have taken place since the last publication of the Standard.

IS 3705 is a necessary adjunct to this standard.

For the purpose of deciding whether a particular requirement of this standard is complied with, the final value, observed or calculated, expressing the result of a test or analysis, shall be rounded off in accordance with IS 2 : 2022 'Rules for rounding off numerical values (*second revision*)'. The number of significant places retained in the rounded off value should be the same as that of the specified value in this standard.

Draft Indian Standard
REFILL, BALL POINT PEN — SPECIFICATION
(Third Revision)

1 SCOPE

This standard covers the requirements for ball point pen refills made entirely from metal or metal and plastic materials. This does not cover jotter and special ball point pen refill where ceramic or ruby ball is used.

2 REFERENCES

The standards listed below contain provisions which through reference in this text, constitute provision of this standard. At the time of publication, the editions indicated were valid. All standards are subject to revision, and parties to agreements based on this standard are encouraged to investigate the possibility of applying the most recent editions of the standards indicated below:

<i>IS No.</i>	<i>Title</i>
IS 1848 (Part 1) : 2018	Writing and printing papers — Specification: Part 1 Account book, azure lead, bond, cream laid and cream wove/printing white/printing coloured/printing offset, printing maplitho, printing white super calendered and typewriting types (<i>fifth revision</i>)
IS 3705 : 1980	Specification for ball point pens (<i>first revision</i>)
IS 4905 : 2015	Random sampling and randomization procedures (<i>first revision</i>)
ISO 24153 : 2009	
IS 5805 : 1993	Ink, ball point pen refill — Specification (<i>first revision</i>)

3 MATERIALS**3.1 Tube (Ink Container)**

Tube shall be made of either any plastic or metal. When made of plastic, the material shall be sufficiently hard and rigid and shall have low moisture absorption. When made of metal, the material shall be rigid and have no visible defects or sharp edges.

3.2 Writing Tip

This may be made from brass or nickel copper alloy or stainless steel or any other non-corrosive material having some hardness characteristic or higher than that of brass.

3.3 Ball

Ball shall be made of stainless steel or tungsten carbide. The hardness of the ball shall be between 650 HV to 750 HV.

3.4 Ink

The ink shall be solvent based. It shall contain no undissolved particles of dye or agglomerates of undispersed pigments. The ink shall be of such quality as to ensure a smooth and continuous writing. In all other respects the ink shall conform to IS 5805.

4 DIMENSIONS

Refills shall be made according to dimensions given in Fig. 1 or Fig. 2 unless otherwise agreed to between the supplier and the purchaser. The diameter of the ball shall be between 0.50 mm to 1.20 mm as agreed to between the purchaser and the supplier. When refills of dimensions other than those given in Fig. 1 or Fig. 2 are ordered, they shall conform to all other provisions of this standard.

5 REQUIREMENTS

5.1 The refill shall be so made as to be straight and concentric with its ball. The refills shall have either a collar or a crimping at a distance from the ball end as specified in Fig. 1 or 2. The refills shall be accurately made so that they are completely interchangeable with the ball point pens conforming to IS 3705 unless otherwise agreed to between the purchaser and the supplier.

5.2 The tube shall be filled with ink and shall not react with it. Colour of the ink shall normally be black, blue, green or red. The ink shall not overflow the barrel or leak around the ball. The refill during disuse shall not ooze out ink when held with ball point tip upward and downward and shall not result in smudginess and discontinuity in writing. The ball shall be so mounted as to have free rotation to enable smooth writing but shall not be loosely fitted nor loosen in use. The tip holding the ball shall be worked over so that its edge shall be smooth and not have any feathers, fins, etc. that would scratch the paper while writing.

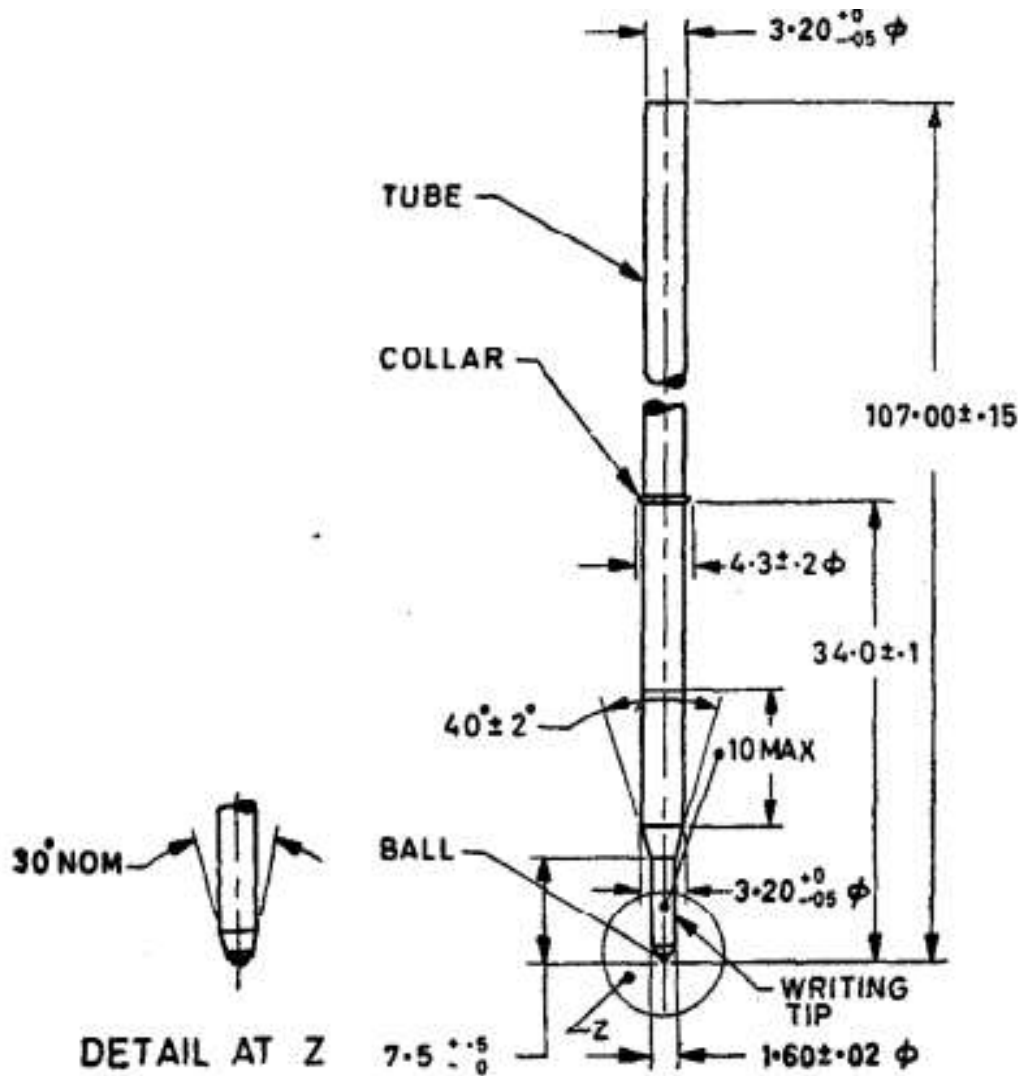

All Dimensions in Millimeters.

FIG. 1 REFILL, BALL POINT PEN, METALLIC

5.3 The refill containing 0.3 g of ink shall write a continuous line of 1 000 m minimum for refill having ball diameter above 0.80 mm and 1 200 m minimum for refill having ball diameter up to 0.80 mm, when tested for length of writing as specified in 6.4.

6 TESTS

6.1 Smoothness of Writing (Routine) Test

Each refill shall be used to draw 50 to 60 continuous loops on a sheet of white super calendered printing paper conforming to IS 1848 (Part 1) within a period of 15 s. The loops shall be continuous without excess deposit of ink and shall be uniform in colour. Writing shall be smooth and refill shall not scratch the paper.

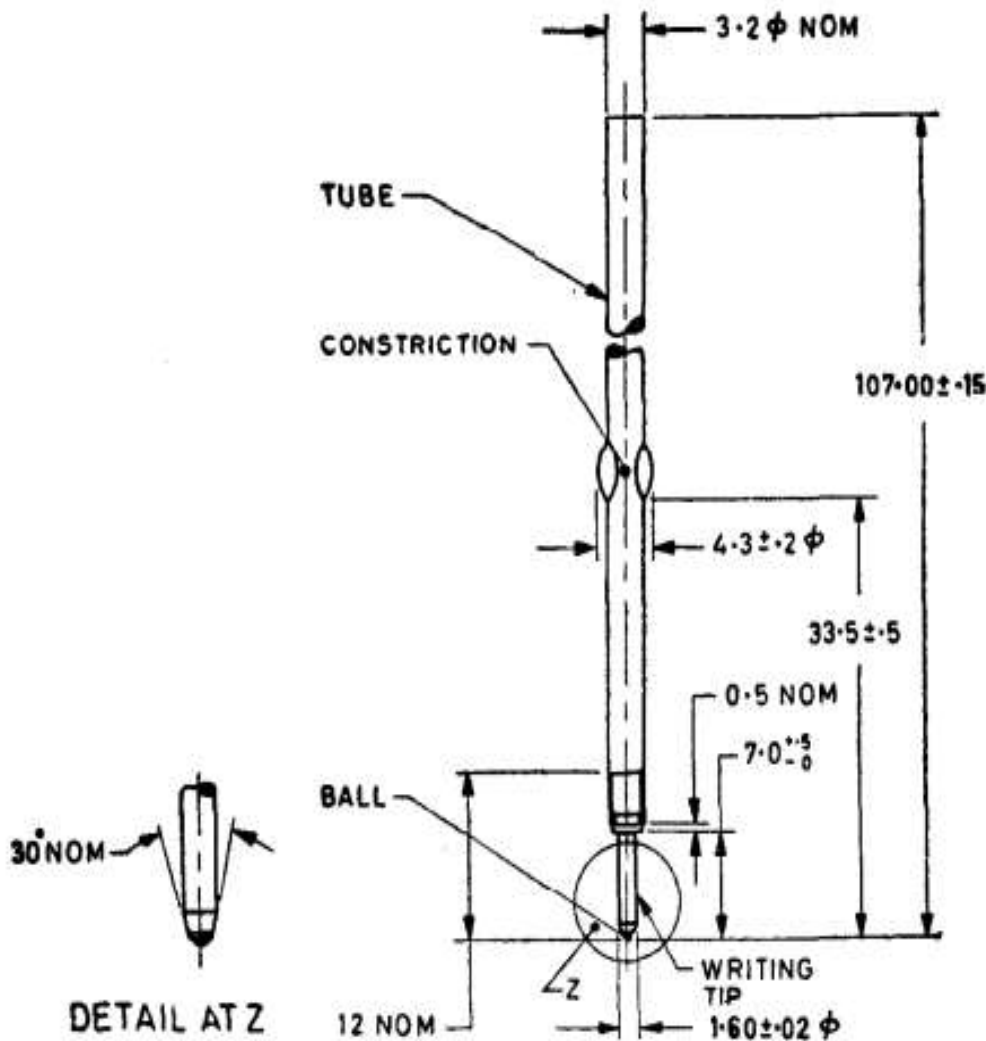

All Dimensions in Millimeters.

FIG. 2 REFILL, BALL POINT PEN, PLASTICS

6.2 Writing Characteristics (Type) Test

The refill shall be tested on a sheet of white super-calendered printing paper or cream laid or cream wove paper conforming to IS 1848 (Part 1) by writing numerous fast as well as slow letters, flourishes, ovals, reversals, angles,

etc. The writing shall be such that it has complete continuity without excess deposit of ink or variation in intensity or line getting split up.

6.3 Starting Test

The refill shall be made to draw a few lines or letters on a sheet of paper to ensure continuous writing. The refill shall then be kept in the vertical position with the writing tip upward for 30 min. The refill shall now be tested on a white super-calendered printing paper or cream laid or cream wove paper conforming to IS 1848 (Part 1) by drawing at least four lines, starting exactly from the margin, with normal writing pressure. The refill shall start marking the first line from a distance of not more than 15 mm and the subsequent line shall start immediately from the margin where they are drawn.

6.4 Length of Writing (Machine Writing)

6.4.1 Apparatus

a) *Standard Paper*

The paper shall be white super-calendered printing paper or cream laid or cream wove paper conforming to IS 1848 (Part 1).

b) *Standard Test Machine*

A mechanical writing machine designed to give continuous writing while rotating the pens simultaneously:

- 1) on their axis, and
- 2) with speed setting of 110 mm/s.

The pens shall be fixed in such a way that they move freely up and down in their holders at a writing pressure of (125 ± 2) g. The acute angle between the paper and the pens shall be $(80^\circ \pm 2^\circ)$. A paper feed mechanism shall feed the rolled paper automatically through the test machine. A revolution counter indicating the number of metres written during the test shall be fitted.

6.4.2 Writing Test

Remove the protective coating, if any, from the balls of the refills under test. Write lines and turns by hand with each test sample until writing commences. Place the pens in the standard test machine and start the writing test. Stop the machine after each 500 m of writing and, using a clean cloth, remove accumulated ink and paper dust from the writing tips. Mark the standard paper at points along its length to indicate each 500 m of writing. Continue the test until each test sample ceases to write a continuous line. Reserve the test papers for assessment of length and continuity of writing. Any interruption of continuity due to any necessary adjustment in the mechanism or change of paper rolls shall be neglected.

6.5 Smearing Test

After writing a few lines or letters on a sheet of white super-calendered printing paper or cream laid or cream wove paper conforming to IS 1848 (Part 1) and waiting for 5 s, the writing shall be rubbed lightly with hand. The ink shall have been dried, so that it could not be smeared. Further there shall be no feathering or spreading or strike through the paper.

6.6 Test for Resistance to Water

Ten different letters shall be written with the refill on a sheet of cream laid or cream wove paper conforming to IS 1848 (Part 1). The paper shall then be immersed in water maintained at a temperature (25 ± 2) °C for 24 h. The paper shall then be removed and allowed to dry and then be examined. The letters shall remain legible.

6.7 Corrosion Resistance Test

The metal parts of the refill shall be dipped in a boiling 10 percent (w/w) aqueous solution of sodium chloride for a period of 15 min. After removal from this solution they shall be immersed in 10 percent (w/w) aqueous solution of

sodium chloride at room temperature for 2 h. They shall then be removed, washed with clean water, wiped with a soft cloth and allowed to dry for 24 h at room temperature. The metal parts shall not show any visible signs of corrosion.

6.8 Accelerated Ageing Test

The refills shall be suspended point down and subjected successively to each of the following conditions:

<i>Exposure</i>	<i>Time (h)</i>	<i>Temperature</i>	<i>Relative Humidity (Percentage)</i>
I	168	(60 ± 1) °C	85 to 90
II	48	(-2 ± 1) °C	—

At the end of the test the refill shall satisfy the writing test given in 6.1 and the ink shall not have leaked nor its colour changed during or after the test.

6.9 Storage Test

The refills shall be kept under normal storage for not less than six months from the time of manufacture. After this period, they shall not have lost the writing characteristics and shall again satisfy the requirements given in 6.2 and 6.3.

7 SAMPLING

Sampling and acceptance criteria for refill, ball point pen shall be as agreed to between the purchaser and the supplier. A recommended scheme for the same is given in Annex A.

8 MARKING

8.1 The refills shall be marked with the manufacturer's name or registered trade-mark, batch number and year of manufacture.

8.1.1 BIS Certification Marking

The product(s) conforming to the requirements of this standard may be certified as per the conformity assessment schemes under the provisions of the *Bureau of Indian Standards Act, 2016* and the Rules and Regulations framed thereunder, and the products may be marked with the standard mark.

9 PACKING

9.1 The refills shall be packed as agreed to between the purchaser and the supplier.

9.1.1 Packing shall be printed to give the following information:

- a) Manufacturer's name or registered trade-mark,
- b) Year of manufacture,
- c) Batch number, and
- d) colour of ink.

ANNEX A

(Clause 7)

SAMPLING SCHEME AND CRITERIA FOR CONFORMITY FOR REFILL, BALL POINT PEN

A-1 LOT

A-1.1 In any consignment, all the ball point pen refills manufactured under similar conditions, from the same raw materials and of same dimensions shall be grouped together to constitute a lot.

A-2 SAMPLING

A-2.1 The number of refills to be selected at random from a lot shall depend upon the size of the lot and shall be in accordance with col 1 and 2 of Table 1.

Table 1 Sample Size and Criteria for Conformity

(Clause A-2.1)

Lot Size (No. of Refills in this Lot)	For Test for Dimension (4) and for Requirements (5.1 To 5.3)		For Tests in 6.1 to 6.8	
	Sample Size	Acceptance Number	Sub-Sample Size	Acceptance Number
(1)	(2)	(3)	(4)	(5)
Up to 150	20	1	8	0
151 to 300	32	2	13	0
301 to 500	50	3	13	0
501 to 1 000	80	5	20	1
1001 to 3 000	125	7	32	2
3001 to 10 000	200	10	32	2
10 001 and above	315	14	50	3

A-2.2 The refills in the sample shall be selected at random from the lot and in order to ensure the randomness of selection, IS 4905 may be used.

A-3 NUMBER OF TESTS AND CRITERIA FOR CONFORMITY

A-3.1 The refills selected according to A-2.1 and A-2.2 shall be inspected for dimensions (4) and requirements (5.1 to 5.3). The refill failing in any one or more of the requirements shall be considered as defective. The lot shall be considered as conforming to the above requirements if the number of defective refills in the sample does not exceed the number given in col 3 of Table 1.

A-3.2 The lot having been found conforming to A-3.1 shall be tested for smoothness of writing test (6.1), writing characteristics test (6.2), Starting test (6.3), length of writing (6.4), smearing test (6.5) and test for resistance to water (6.6). For this purpose, a sub-sample of size given in col 4 of Table 1 shall be taken from the refills selected as in A-2.1 and A-2.2. Each of the refills in the sub-sample shall be subjected to the test mentioned above. A refill failing in one or more of the tests shall be considered as defective. The lot shall be considered as conforming to the above-

mentioned requirements if the number of defectives in the sub-sample does not exceed the number given in col 5 of Table 1.

A-3.3 The lot having been found conforming to **A-3.2**, a sample of refills shall be tested for corrosion resistance test **(6.7)** and accelerated ageing test **(6.8)**. A refill failing in any one of the tests shall be considered as defective. The lot shall be considered as conforming to the requirements of the tests if the sample passes both the tests.

A-3.4 The lot shall be accepted if **A-3.1**, **A-3.2** and **A-3.3** are satisfied.