

BUREAU OF INDIAN STANDARDS

DRAFT FOR COMMENTS ONLY

(Not to be reproduced without permission of BIS or used as an Indian Standard)

Draft Indian Standard

**RESPIRATORY PROTECTIVE DEVICES —
POWERED FILTERING DEVICES INCORPORATING A HELMET OR HOOD —
SPECIFICATION**

(ICS 13.340.30)

Occupational Safety and Health Sectional
Committee, CHD 08

Last Date for Comments: 26 August 2024

Occupational Safety and Health Sectional Committee, CHD 08

FOREWORD

(Formal clauses shall be added later)

Powered Air-Purifying Respirators (PAPRs) are advanced respiratory protective devices that use a battery-powered blower to draw air through filters, providing clean air to the user through a face piece, hood, or helmet.

This standard specifies requirements of PAPR with Hood or Helmet.

In the preparation of this standard, considerable assistance has been derived from the following standard:

EN 12941:1998/A1:2003 : Respiratory protective devices - Powered filtering devices incorporating a helmet or a hood - Requirements, testing, marking

The use of PAPRs with hoods and helmets is particularly advantageous in settings such as healthcare, pharmaceuticals, manufacturing, and industrial operations where high levels of airborne particulates, chemical vapours, or biological agents are present. These systems are designed to maintain a positive pressure within the hood or helmet, thereby preventing contaminants from entering even if there are minor leaks. This feature makes them highly effective in environments where air quality is compromised, ensuring that the wearer is continuously supplied with clean, and breathable air. Furthermore, PAPRs with hoods and helmets can be used by individuals with facial hair or those who find tight-fitting respirators uncomfortable or impractical, providing a versatile solution to meet diverse workplace safety requirements.

For the purpose of deciding whether a particular requirement of this standard is complied with, the final value, observed or calculated, expressing the result of a test or analysis, shall be rounded off in accordance with IS 2 : 2022 'Rules for rounding off numerical values (*second revision*)'. The number of significant places retained in the rounded off value should be the same as that of the specified value in this standard.

Draft Indian Standard
**RESPIRATORY PROTECTIVE DEVICES —
POWERED FILTERING DEVICES INCORPORATING A
HELMET OR HOOD — SPECIFICATION**

1 SCOPE

This standard specifies minimum requirements for powered filtering devices incorporating helmet or hood with gas, particle or combined filter(s) for respiratory protection. It does not cover devices designed for use in circumstances where there is or might be an oxygen deficiency (oxygen less than 19.5 percent by volume). Also it does not cover respiratory protective devices designed for escape purposes..

2 REFERENCES

The standards listed in Annex A contains provisions which through reference in this text, constitute provisions of this standard. At the time of publication, the editions indicated were valid. All standards are subject to revision and parties to agreements based on this standard are encouraged to investigate the possibility of applying the most recent editions of the standards indicated in Annex A.

3 TERMINOLOGY

3.1 Definitions

For the purposes of this Indian standard the definitions given in IS 8347 and the following shall apply.

3.1 Re-Usable Particle or Combined Filter — A particle or combined filter intended to be used for more than a single shift.

4 DESCRIPTION

The device typically consists of the following;

- a) A face piece which can be hood as defined in IS 8347 or a device which seals the face, excluding face pieces specified in IS 14166 or IS 14746. Either type of face pieces may incorporate a helmet possibly for combined risks e.g. to provide head protection against mechanical impact and/or a visor to provide eye and face protection against given risks.
- b) A turbo unit designed to be carried/worn by the wearer which supplies filtered ambient air to the face piece. The energy supply for the turbo unit may or may not be carried by the person,
- c) A filter or set of filters through which air supplied passes and makes contaminant free,
- d) Exhalation valves or other outlets depending on the design by which exhaled air and air in excess of the wearer's demand is discharged.

5 DESIGNATION

Respiratory protective devices meeting the requirements of this standard shall be designated in the following manner considering Classification described in 6

Powered filtering device/Standard No/(Class) (type) (options)

For example: Powered filtering device/IS ____/TH2A2P SL

6 CLASSIFICATION

The complete devices are classified and designated according to the maximum inward required as given in Table 1.

Table 1 Classification

(Clauses 6, 7.4, 7.6.3, 7.11.1.1, and 7.11.2.4)

Classification of complete device			Maximum Inward Leakage percent	Maximum particle Filter penetration	
Class	Gas filter Type and class (if applicable)	Particle filter (if applicable)		NaCl Aerosol percent	Paraffin Oil mist percent
TH 1	A1,2 or 3 B1,2 or 3 E1,2 or 3 K1, 2 or 3 AX SX	P	10	10	10
TH 2	A1,2 or 3 B1,2 or 3 E1,2 or 3 K1, 2 or 3 AX SX	P	2	2	2
TH 3	A1,2 or 3 B1,2 or 3 E1,2 or 3 K1, 2 or 3 AX SX	P	0.2	0.2	0.2

Example: TH2B1P: a powered filtering device incorporating a helmet or a hood (TH) fitted with a combined gas filter and a particle filter (B1P) and where the inward leakage of the complete device is 2 percent or less.

7 REQUIREMENTS

7.1 Materials

7.1.1 General

The device shall be made of suitable material to withstand normal usage and exposure to those temperatures, humidifies and corrosive environments that are likely to be encountered.

Testing shall be done in accordance with **8.2**.

7.1.2 Compatibility with skin

Materials that may come into contact with the wearer's skin shall not be known to be likely to cause skin irritation or any other adverse effect to health.

Testing shall be done in accordance with **8.2**

7.1.3 Cleaning and disinfection

The materials used in the construction of the device shall withstand the cleaning and disinfecting agents and procedures recommended by the manufacturer.

Testing shall be done in accordance with **8.2** and **8.3.5.16**.

7.1.4 Surface finish

The finish of any part of the device likely to be in contact with the wearer shall be free from sharp edges and burrs.

Testing shall be done in accordance with **8.2**

7.2 Resistance to Temperature

After conditioning in accordance with **8.1.2.**, the complete device excluding filters shall show no appreciable deformation of major components, nor shall all these components separate within the complete device. The requirements of **7.3** to **7.10** and **7.11** to **7.17** shall continue to be met.

Testing shall be done in accordance with **8.1**.

NOTES

- 1 The complete device is deemed to exclude the battery charger, unless the charger is integral with device.
- 2 The requirements for conditioning of filters, prior to testing, are given in **8.1**.

7.3 Helmets and Hoods

7.3.1 General

If the device is intended to provide in additional protection for head, eye or face, against possible risks, it shall comply with relevant requirements of applicable national standards covering related protectors. (for example, IS 5983 and IS 2925)

Additions to the equipment specified by the manufacturer shall not impair the respiratory protective performance of the equipment complying with the standard.

When the hood or helmet does not include an integral turbo unit:

- a) The hood or helmet shall not incorporate a thread in accordance with IS 14138 Part 1;
- b) It shall not be possible to fit the filter(s) directly to the hood or helmet

7.3.2 Head Harness

The head harness (if fitted) of a hood or helmet shall be capable of being adjusted to fit a range of head sizes.

Testing shall be done in accordance with **8.2**, **8.3** and **8.16**.

7.3.3 Visor

7.3.3.1 Visors shall not distort vision nor shall any misting occur which significantly affects vision as subjectively determined in the course of testing

Where anti-misting compounds are used or specified by the manufacturer, they shall be compatible with eyes, skin and the device under the foreseeable conditions of use.

Testing shall be done in accordance with **8.3** and **8.16**.

7.3.3.2 An average visual field score (VFS) shall be at least 98. Six out of 8 dots of the section between 20° and 30°; 340° and 350°, 150° and 160° and 190° and 200° in the modified VFS scale shall be within the number counted. In addition, at least two of the four critical dots which lie in the section between 20° and 30°; 340° and 350°, 150° and 160° and 190° and 200° shall be included in the field score (*See Fig. 1*). Testing shall be performed in accordance with IS 17274 (Part 11) without corrective eyewear

Testing shall be done in accordance with **8.4**.

Devices shall also be assessed for field of vision during the practical performance test.

Testing shall be done in accordance with **8.16**

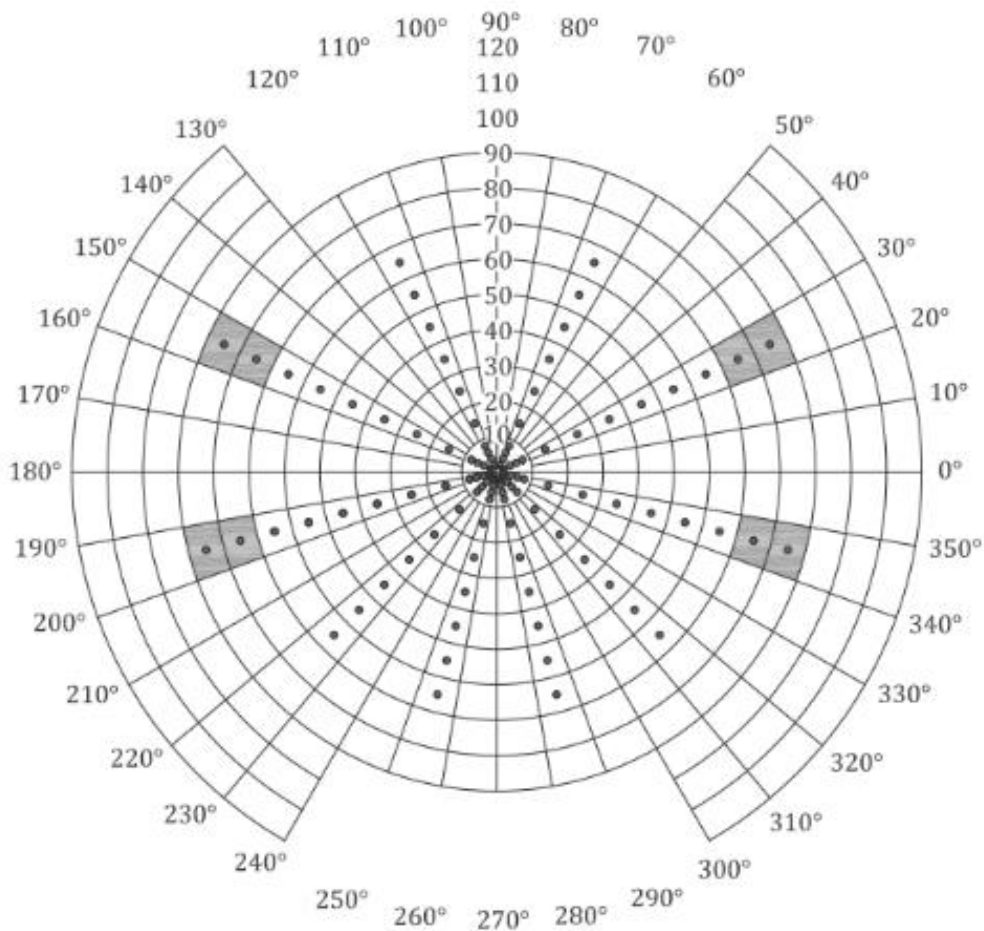

FIG. 1 VISUAL FIELD SCORE (VFS) PLOTTING CHART

7.3.3.3 If it is intended additionally to provide protection against certain type of non-ionizing radiation then the protection shall comply with IS 5983 and applicable Indian standard as appropriate.

If means of protection against non-ionizing radiation is integral with the equipment covered by this standard then the field of vision shall be measured as described in 8.4 and reported for information only and the equipment shall comply with IS 5983, IS 16321.

7.3.3.4 The visor shall not be visibly damaged and the device shall comply with requirements specified in 7.4.

Testing shall be done in accordance with 8.5

7.4 Inward Leakage

When tested at the manufacturer's minimum design flow rate the inward leakage of the test substance for each of the exercises shall not exceed the levels given in the appropriate class from column 4 of Table 1, for each of the 10 test subjects.

Testing shall be done in accordance with 8.3.

7.5 Breathing Resistance

The positive pressure under the helmet or hood shall not exceed 5 mbar.

Testing shall be done in accordance with 8.6

7.6 Air Supply

7.6.1 When mounted on a dummy head or torso the flow into the helmet or hood shall be not less than the minimum design flow rate for the manufacturer's stated design duration which shall not be less than 4 h.

Testing shall be done in accordance with **8.7**

The flow rate and distribution of the air under the helmet or hood shall not cause distress to the wearer (for example by excessive local cooling of the head and face or by causing eye irritation)

Testing shall be done in accordance with **8.3** and **8.16**.

7.6.2 It shall not be possible to switch off the air supply inadvertently as assessed during the practical performance test.

Testing shall be done in accordance with **8.16**

7.6.3 If a means is provided to adjust the air supply then it shall not be possible to change the classification during use. The mechanism which adjusts the flow rate shall simultaneously indicate the appropriate reference to the selected classification (*see* Table 1) as specified in the manufacturer's information. The mechanism shall be so designed that it is not possible inadvertently to change the air flow.

A means for adjusting the air flow during use within a classification may be provided by manufacturer.

Testing shall be done in accordance with **8.2** and **8.16**

7.7 Checking and Warning Facilities

7.7.1 A means shall be provided to check that the manufacturer's minimum design flow rate is exceeded.

7.7.2 Class TH2 and Class TH3 devices shall be fitted with a warning facility that indicates to the wearer during use when a further check in accordance with **7.7.1** and the manufacturer's instructions is necessary.

7.7.3 A means for checking the correct functioning of the warning facility shall be provided.

7.7.4 The facilities provided under **7.7.1**, **7.7.2** and **7.7.3** shall be tested to ensure that it operates at or above the minimum design flow rate.

Testing shall be done in accordance with **8.2**, **8.16** and the manufacture's information.

7.8 Clogging

Where particle or combined filters (including special filters) are fitted, the device shall be tested for clogging. On completion of this test:

- a) the flow rate to the device shall not have fallen below the manufacturer's minimum design flow rate, and
- b) the filters shall meet the penetration requirements of **7.11.1.1**

Testing shall be done in accordance with **8.8**

7.9 Electrical Components

Electrical components shall be so designed that it is not possible to inadvertently reduce or reverse the air flow.

If the device is claimed to be intrinsically safe for use in potentially explosive atmospheres it shall comply with the appropriate requirements of IS /IEC 60079 (Part 0) and (Part 11).

If the power supply is a battery it shall be non-spillable type.

Protection against the effects of an occurrence of a short circuit shall be provided for the battery.

Testing shall be done in accordance with **8.2** and **8.16**.

NOTE— Long power leads should be avoided. The use of very low voltages is recommended, which, in this context, means less than 60 V(d.c.) or less than 25 V (a.c.) (50Hz).

7.10 Breathing Hose

7.10.1 Any breathing hose shall permit free head movement without danger of being caught up, as subjectively assessed by test subjects.

Testing shall be done in accordance with **8.3** and **8.16**

7.10.2 The air flow when the load is applied shall not be reduced by more than 5 percent of the manufacturer's minimum design flow rate.

There shall be no distortion 5 min after completion of the test.

Testing shall be done in accordance with **8.9**

7.10.3 Hoses and couplings shall meet the requirements given in Table 2 shall not become disconnected or visibly damaged. Where multiple hoses are fitted to the device each hose shall meet the requirements given in Table 2.

Testing shall be done in accordance with **8.10**.

Table 2 Strength of hose and couplings

(Clauses 7.10.3 and 7.10.4)

Classification	Strength N (Newton)
TH1	50
TH2	100
TH3	250

7.10.4 *Strength of Coupling to Hood*

The coupling between hose and helmet/hood shall comply with the strength requirements of Table 2 and shall not become disconnected or suffer visible damage.

Testing shall be done in accordance with **8.10**.

7.11 Filters

7.11.1 *Types and Classification*

7.11.1.1 *Particle filters*

Powered particle filtering devices shall be classified according to their penetration as given in col 5 and 6 of Table 1.

Three levels are classified and shall be designated:

THyP

Where y is the inward leakage class 1, 2 or 3.

The protection provided by a class 2 or a class 3 filter includes that provided by the corresponding filter of lower class or classes.

7.11.1.2 *Gas filters*

Powered gas filtering devices shall be classified according to their application and protection capacity.

They shall be designated:

ThyGasz

Where y is the inward leakage class 1,2 or 3 and z is the capacity of the gas filter 1, 2 or 3 and where 'Gas' means one of the "types" of filters listed in a) (i) or (ii) or (iii).

a) Types of filters. Gas filters are contained in one of the following types or combinations of them. If a filter is a combination of types, it shall meet the requirements of each type separately.

i) Types A, B, E and K.

Type A: For use against certain organic gases and vapours with a boiling point higher than 65° C as specified by the manufacturer.

Type B: For use against certain inorganic gases and vapours as specified by the manufacturer (excluding carbon monoxide).

Type E: For use against sulfur dioxide and other acidic gases and vapours as specified by the manufacturer.

Type K: For use against ammonia and organic ammonia derivatives as specified by the manufacturer.

ii) Special filters

Special filters shall only be in TH3 devices and shall include a particle filter on the inlet side. They are:

Type NO: For use against oxides of nitrogen, for example, NO, NO₂, NOX,

Type Hg: For use against mercury.

iii) AX and SX filters

Type AX: For use against certain low boiling compounds (boiling point ≤ 65°C) as specified by the manufacturer.

Type SX: For use against specific compounds.

b) Classes of filters

i) Gas filters of types A, B, E and K are classified in one of the following classes:

Class 1: Low capacity

Class 2 : Medium capacity

Class 3: High capacity

The gas capacity provided by a class 2 or class 3 filter includes that provided by the corresponding filter of lower class or classes.

Only one class of special filter is specified.

7.11.1.3 Combined filters

Combined filters shall be specified and described as separate entities in accordance with 7.11.1.1 and 7.11.1.2 that is ThyGasZP (for example, TH3A2P),

Where

$y = 1, 2 \text{ or } 3$

$z = 1, 2 \text{ or } 3$

and

Gas = one or more of the types of gas filter.

7.11.2 Design and Performance

7.11.2.1 Construction

The connection between filter(s) and the mating part of the device shall be robust and leak tight.

The connection between filter and the mating part may be achieved by a special type of connection or by screw thread connection (including threads other than the standard thread).

The standard thread is defined in IS 14138 (part 1).

Filters other than prefilters shall be designed to be irreversible and shall be readily replaceable without use of special tools.

The particle filter of combined filters shall be on the influent side of the gas filter.

Testing shall be done in accordance with **8.2**.

7.11.2.2 Materials

Internally the filter shall withstand corrosion by the filtering media.

Material from the filter media released by the air flow through the filter shall not constitute a hazard or nuisance for the wearer.

7.11.2.3 Mechanical strength

After testing in accordance with **8.11** filters shall show no mechanical defects. After a visual inspection they shall meet the performance requirements given in **7.11.2.4**

7.11.2.4 Protection efficiency/capacity

7.11.2.4.1 Particle filters

Particle filters shall comply with the requirements given in col. 5 or 5 and 6 Table 1.

Filters for use against solid and liquid aerosols shall be tested against sodium chloride and paraffin oil.

Filters only for use against solid and water-based aerosols shall be tested against sodium chloride only.

Filters not meeting the requirements after the storage test shall be classified as single shift use only.

Testing shall be done in accordance with **8.12.1** and **8.12.2**

7.11.2.4.2 Gas filters type A, B, E and K and combined filters

The filters shall comply with the requirements given in Table 3.

Testing shall be done in accordance with **8.12.1**, **8.12.3.1** and **8.12.3.2**

Where such a gas filter is combined with a particle filter, the combined filter shall comply with the penetration requirement for the particle filter given in Table 1 in addition to the requirements of Table 3.

7.11.2.4.3 Special filters

Special filters shall comply with the requirements of Table 4 and the penetration requirements for the particle filter given in Table 1.

Testing shall be done in accordance with **8.12.1**, **8.12.3.1** and **8.12.3.3**.

Only one class of special filter is specified.

7.11.2.4.4 AX filters

AX filters shall comply with the requirements of Table 5 and if applicable with the penetration requirements for the particle filter given in Table 1.

Testing shall be done in accordance with **8.12**, **8.12.3.1** and **8.12.3.4**.

Table 3 Protection capacity of gas filters of types A, B, E and K

(Clause 7.11.2.4.2)

Filter type and class	Test gas	Minimum breakthrough time at test condition
		min

A1	Cyclohexane (C ₆ H ₁₂)	70
B1	Chlorine (Cl ₂)	20
	Hydrogen sulfide(H ₂ S)	40
	Hydrogen cyanide (HCN)	25
E1	Sulfur dioxide (SO ₂)	20
K1	Ammonia (NH ₃)	50
A2	Cyclohexane (C ₆ H ₁₂)	70
B2	Chlorine (Cl ₂)	20
	Hydrogen sulfide(H ₂ S)	40
	Hydrogen cyanide (HCN)	25
E2	Sulfur dioxide (SO ₂)	20
K2	Ammonia (NH ₃)	50
A3	Cyclohexane (C ₆ H ₁₂)	35
B3	Chlorine (Cl ₂)	20
	Hydrogen sulfide(H ₂ S)	40
	Hydrogen cyanide (HCN)	25
E3	Sulfur dioxide (SO ₂)	20
K3	Ammonia (NH ₃)	40

NOTE — The minimum breakthrough times given in tables 3, 4 and 5 are intended only for laboratory tests under standardized conditions. They do not give an indication of the possible service time of the filter in practical use. Possible service times can differ from the breakthrough times determined according to this standard in both directions, positive and negative depending on the conditions of use.

Table 4 Protection capacity of special filters

(Clause 7.11.2.4.3)

Filter type	Test gas	Minimum breakthrough time at test condition
NOP	Nitric oxide (NO)	20 min
	Nitrogen dioxide(NO ₂)	20 min
HgP	Mercury vapour (Hg)	100 h

NOTE — Only one class of special filter is specified.

Table 5 Protection capacity of AX filters

(Clause 7.11.2.4.4)

Test gas	Minimum breakthrough time at test condition Min

Dimethyl ether (CH ₃ -O-CH ₃)	50
Isobutane (C ₄ H ₁₀)	50

7.11.2.4.5 *SX filters*

7.11.2.4.5.1 *Sorption*

SX filters shall have a breakthrough time of not less than 20 min.

NOTE — The minimum breakthrough time is intended only for laboratory tests under standardized conditions. They do not give an indication of the possible service time of the filter in practical use. Possible service times can differ from the breakthrough times determined according to this standard in both directions, positive and negative depending on the conditions of use.

Testing shall be done in accordance with **8.12.1**, **8.12.3.1** and **8.12.3.5**.

7.11.2.4.5.2 *Desorption*

The effluent concentration from SX filters shall not be greater than 5 ml/m³ of the test gas at any time during the test.

Testing shall be done in accordance with **8.12.1**, **8.12.3.1** and **8.12.3.5**.

7.11.2.4.5.3 Where such a gas filter is combined with a particle filter, the combined filter shall comply with the penetration requirement for the particle filter given in Table 1 in addition to the requirements of **7.11.2.4.5.1** and **7.11.2.4.5.2**.

7.11.2.5 *Multiple filters*

Where the device employs multiple filters through which the flow is proportioned, the flow through the filters shall be balanced. The flow through multiple filters is considered to be balanced if the filter resistance conforms with the following expression:

$$\left(\frac{|\Delta \text{flow resistance}|}{\text{mean flow resistance}} \right)_{\max} \leq 0.2$$

To assess this balance, the resistance of the filters shall be measured at a flow rate which is given by the manufacturer's minimum design flow rate divided by the number of filters through which the air flow is proportioned.

7.12 **Noise Level**

The noise generated by the device shall not exceed 75 dB (A).

Testing shall be done in accordance with **8.13**.

7.13 **Carbon Dioxide Content of the Inhalation Air**

The carbon dioxide content of the inhalation air (dead space inside facepiece) shall not exceed an average of 1 percent by volume.

Testing shall be done in accordance with **8.14**.

7.14 **Resistance to Flame**

No part of the device shall continue to burn after removal from the flame.

Testing shall be done in accordance with **8.15**

The device is not required to meet the other requirements of this standard after being subjected to this test.

7.15 **Exhalation Means**

7.15.1 Where exhalation means are fitted they shall comply with the requirements of **7.15.2** to **7.15.6**

7.15.2 Exhalation means shall be such that they can be readily maintained and correctly replaced.

Testing shall be done in accordance with **8.2**

7.15.3 Exhalation means shall function correctly in all orientations which are likely to be encountered in use. Testing shall be done in accordance with **8.2** and **8.16**

7.15.4 Exhalation means shall be protected against dirt and mechanical damage.

7.15.5 Exhalation means shall operate correctly as assessed by the procedures of **8.2**, **8.3** and **8.6** after a continuous exhalation flow of (300 ± 15) l/min for a period of (60 ± 6) s. This test shall be carried out immediately after the test described in **8.7**.

The batteries shall be recharged in accordance with the manufacturer's information before testing the breathing resistance in accordance with **8.6**.

7.15.6 The housing of the exhalation means shall be attached to the facepiece such that it can withstand axially a tensile force of (50 ± 15) N for a period of (10 ± 1) s.

Testing shall be done in accordance with **8.10**.

7.16 Mass

The total mass of the device shall not exceed 5 Kg of which not more than 1.5 kg shall be carried on the head.

7.17 Practical Performance

The device shall undergo practical performance tests under realistic conditions. These general tests serve the purpose of checking the device for imperfections that cannot be determined by the tests described elsewhere in this standard.

Where practical performance tests show the device has imperfections related to wearer's acceptance, the test house shall provide full details of those parts of the practical performance tests which revealed these imperfections. This enables other test houses to duplicate the tests and assess the results thereof.

Testing shall be done in accordance with **8.16**

8 TESTING

Testing schedule is given in Table 6.

Table 6 Testing Schedule

(Clause 8)

Requirement Clause	Title	Number of samples	Conditioning	Test Clause	Cross Referred Clauses
(1)	(2)	(3)	(4)	(5)	(6)
7.1	Materials	2	1 A.R., 1T.C.	8.2, 8.3	
7.2	Resistance to temperature	1		8.1, 8.2	7.3 to 7.10, 7.12 to 7.17
7.3	Helmets and hoods	2	1 A.R., 1T.C.	8.2, 8.3, 8.4 8.5, 8.16	7.2, 7.4
7.4	Inward leakage	2	1 A.R., 1T.C.	8.3, 8.17	7.2
7.5	Breathing resistance	2	1 A.R., 1T.C.	8.6	7.2
7.6	Air Supply	2	1 A.R., 1T.C.	8.2, 8.3, 8.7 8.16	7.2

7.7	Checking and warning Facilities	2	1 A.R., 1T.C.	8.2, 8.16	7.2
7.8	Clogging	2filters/ aerosol	A.R.	8.8	7.2, 7.11.1.1
7.9	Electrical components	2	1 A.R., 1T.C.	8.2, 8.16	7.2
7.10	Breathing hose	2	1 A.R., 1T.C.	8.3, 8.9 8.10, 8.16	7.2
7.11	Filters	3filters/ aerosol	3 M.S. & T.C.	8.1.2, 8.2, 8.11, 8.12	
		4 filters/gas	2 M.S, 2M.S & T.C	8.1.2, 8.2, 8.11, 8.12	
7.12	Noise Level	2	1 A.R., 1T.C.	8.13	7.2
7.13	Carbon dioxide content of inhalation air	2	1 A.R., 1T.C.	8.14	7.2
7.14	Resistance to flame	2	1 A.R., 1T.C.	8.15	7.2
7.15	Exhalation means	2	1 A.R., 1T.C.	8.2, 8.3, 8.6 8.7	7.2
7.16	Mass	2	1 A.R., 1T.C.	-	7.2
7.17	Practical performance	2	1 A.R., 1T.C.	8.16	7.2
8.2	Visual inspection	2	1 A.R., 1T.C.	8.2	7.1, 7.2, 7.3 7.6, 7.7, 7.9, 7.11

NOTE — For a particular requirement given in columns 1 and 2 of the table, the relevant test clauses are given in column 5. In some cases there are other associated requirement clauses and these are given in column 6.

A.R. = As received (means “not conditioned”);

T.C. = Temperature conditioned (**8.1**);

M.S. = Mechanical strength (**8.11**).

Before performing tests involving human subjects account shall be taken of national concerning the medical history, examination or supervision of the test subjects.

If no special measuring devices or measuring methods are specified, commonly used methods and devices shall be applied.

8.1 Conditioning

8.1.1 General

All tests on complete devices shall be carried out on two samples. One shall be tested “as received” and other after conditioning in accordance with **8.1.2**. Except where otherwise indicated, filters used in the tests with complete devices shall be “as received”.

8.1.2 Complete Device

Store the complete device for (72 ± 1) h at one of the extremes of temperature and humidity given in manufacturer's information. Allow the device to return to ambient conditions for at least 4 h and then store for (72 ± 1) h at the other extreme of temperature and humidity given by the manufacturer.

8.1.3 Filters

8.1.3.1 Aerosol penetration and gas capacity

Four filters shall be tested for each gas or aerosols. Two filters "as received" shall be subjected to the mechanical strength test prior to aerosol or gas testing. The two further filters shall be subjected to conditioning as described in **8.1.2**, and then to mechanical strength testing as described in **8.11**, prior to aerosol or gas testing.

8.1.3.2 Clogging

"As received" filters shall be used for this test.

8.2 Visual Inspection

A visual inspection of the device is carried out and the results reported as appropriate. The visual inspection includes marking and information supplied by the manufacturer.

8.3 Inward Leakage:

Refer **11.2 & 11.3** of IS 17274 (Part 1).

8.3.1 General

- a) Two methods are specified, namely, one using sodium chloride and the other sulfur hexafluoride. The general principle of the test is the same using either of the two test substances but the test substance to be used depends on the type of device being tested and shall be chosen in accordance with Table 7. If a gas or combined filter device manufactured from non-porous material (as tested in **8.17** if necessary) is obviously open to the atmosphere or incorporates an unsealed stitched seam it may be tested with sodium chloride. If the non-porosity is doubtful then it shall be tested using Sulfur hexafluoride.
- b) When Table 7 requires total inward leakage (TIL) to be determined the complete device on test is used in a sodium chloride test atmosphere. When Table 7 requires inward leakage excluding filter penetration (IL) to be determined, the device on test may be supplied with breathable air (free of the test substances) or by replacing gas or combined filters with high efficiency particle filters. If the breathable air method is used the air supply (from external source) is attached to the filter (s) or equipment normally used with the apparatus. For this purpose lightweight hose (s) and plenum cap (s) can be attached to the filter element (s) of the test device and air free of the substance supplied to it at a flow resistance (including hoses) representative of that measured for the unmodified device.
- c) If the high efficiency filter method is used then these surrogate devices shall have the same mass and breathing resistance as their gas/vapour counterparts.
- d) Prior to the test the equipment shall be examined to ensure that it is in good working condition and that it can be used without hazard.

8.3.2 Principle

A test subject, wearing the complete device on test, walks on a horizontal treadmill surrounded by an atmosphere containing a known concentration of the test substance. The flow rate in the equipment is adjusted to, and maintained at, the manufacturer's minimum design flow rate. The percentage inward leakage of the test substance into the breathing zone is measured continuously.

Dilution of the test atmosphere by clean air emanating from the device under test does not affect the accuracy of the measurement of leakage because of the large volume and continuous replacement of the test atmosphere.

Table 7 Type of device and test substance to be used in inward leakage test

(Clause 8.3.1)

Type of Device	Test substance	Number of test subjects	Type of measurement	Clause for report of result
Particle	Sodium chloride	10	TIL	7.3.7.3
Gas	Sulfur hexafluoride	10	IL	7.3.6.4
	or Sodium chloride*	10	IL	7.3.7.3
Combined	Sodium chloride*	10	TIL	7.3.7.3
	Sodium chloride**	5	TIL	7.3.7.3
	and Sulfur hexafluoride**	5	IL	7.3.6.4
<p>* Not porous as assessed by test procedure in 8.17</p> <p>** Porous as assessed by test procedure in 8.17</p> <p>TIL=Total inward leakage IL=Inward leakage excluding filter penetration</p>				

8.3.3 Test Subjects and Number of Tests

Two complete devices are tested, each being tested on five test subjects. Both devices shall be tested for robustness of the visor, prior to the inward leakage tests. One complete device is tested “as received” to provide five inward leakage results. The other complete device is tested after being conditioned as described in **6.2** to provide a further five inward leakage results. The test subjects selected shall be familiar with using such similar equipment. Male or female test subjects shall be used.

8.3.4 Apparatus

The apparatus is used for both test substances.

8.3.4.1 Enclosure

An enclosure is positioned over a treadmill and is capable of being filled with the test atmosphere which preferably enters the top of the enclosure via a duct and flow distributor and is directed downwards over the head of the test subject. The concentration of the test substance inside the effective working volume is checked to ensure it is sufficiently homogeneous. The enclosure is large enough to permit walking on the treadmill without interference. Provision is made for the positioning of a supplementary fan, not less than 350 mm in diameter, inside the enclosure such that an air velocity of 2 m/s across the enclosure can be produced in the vicinity of the subject’s head.

The air velocity through the enclosure measured close to the test subject’s head, with the test subject standing centrally on the treadmill and without the supplementary fan in operation, shall be 0.12 m/s to 0.2 m/s.

The design of the enclosure shall be such that the device worn by the test subject can be supplied if necessary with breathable air (free of the test substance). Such an air supply is attached to the filter or equipment normally used with the device.

It is important that the attachment of the hose supplying clean air does not affect the fit of the equipment on the test subject nor should its fitting replace any seals incorporated in the equipment under test. If necessary the hose can be supported.

8.3.4.2 Treadmill

A level treadmill capable of working at 6 km/h.

8.3.4.3 Sampling probe and connections

The probe consists of a length of tubing fitted with a plastics ball of approximately 20 mm diameter and having eight holes each of 1.5 mm diameter spaced equidistant around the circumference of the ball [see Fig. 2(a)]. For devices having a rigid visor may act as a support for the sampling probe after piercing at a suitable position. Connections to the sampling probe need to be sealed into the hole made in the visor.

For devices employing flexible hoods it may be necessary to fit a head harness to the test subject. This harness can then carry the sampling probe and associated connection [see Fig. 2 (b)].

For tests on all types of device, the sample holes in the ball probe should lie in the position shown in Fig. 2(a) and (b). A second sampling probe is provided, to measure the ambient concentration of test substance in the test chamber. The sampling probes are connected to the analyzing instruments by means of thin tubing the length of which is kept as short as possible.

The sampling is continuous at a rate up to 3 l/min.

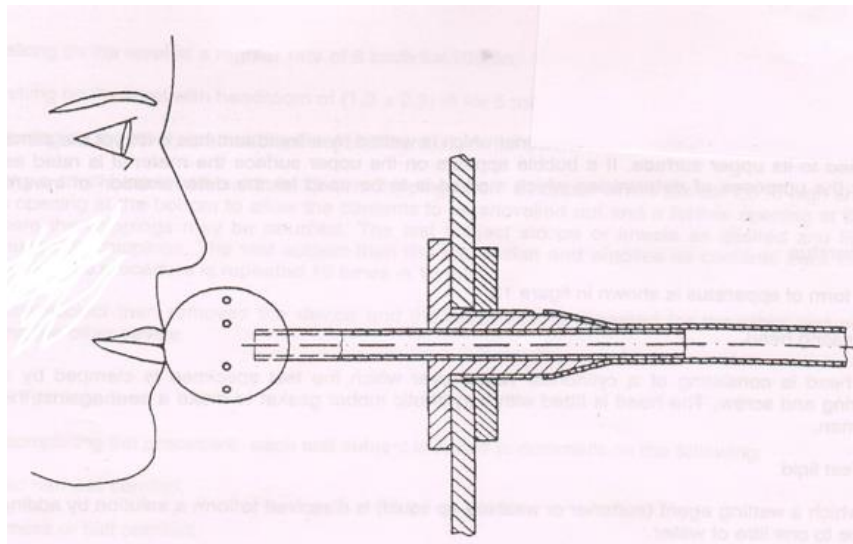
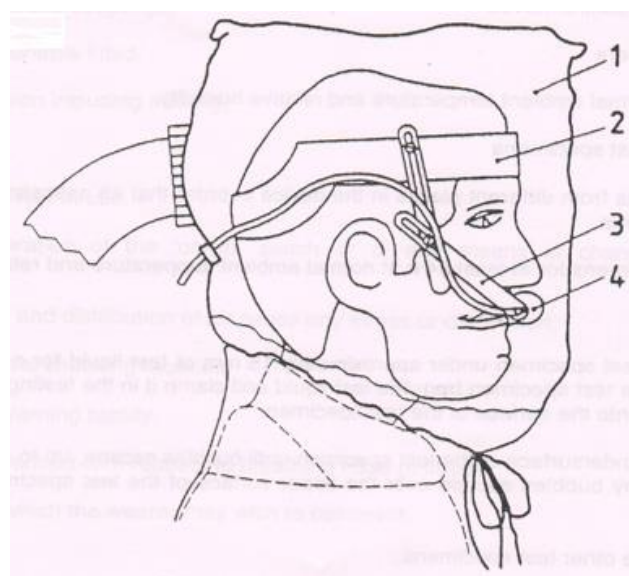

FIG. 2(A): BALL PROBE USED ON DEVICE WITH RIGID VISOR



- | | |
|-------------------|--------------------------|
| 1 Hood under test | 3 Adjustable plastic arm |
| 2 Headband | 4 Sampling probe |

FIG. 2(B): TYPICAL ARRANGEMENT FOR SAMPLING FROM DEVICE WITH
“SOFT PLASTIC HOOD

8.3.4.4 *Detection system*

The detection system including sampling probes and connections shall have a response time of less than 20 s for a response of 10 percent to 90 percent of the full scale deflection of the indicator used.

8.3.4.5 *Power supply*

The power supply shall enable the manufacturer’s minimum design flow rate to be maintained throughout the test procedure. The battery fitted to the device shall not be used.

8.3.5 *Test procedure*

The test procedure is the same for the both test substances.

8.3.5.1 Place all the samples tubes initially in close proximity to one another within the enclosure and the resistance of the sample tubes adjusted for example, by means of screw clip, so that identical readings for the test substances concentration are obtained from each sample tube.

8.3.5.2 Ask the test subject to read the manufacturer’s fitting information and necessary show them how to fit the device correctly in accordance with the fitting information.

8.3.5.3 Inform the test subjects that if they wish to adjust the face piece during the test they may do so. However, if this is done the relevant section of the test will be repeated having allowed the system to re-settle.

8.3.5.4 Adjust the flow rate to the manufacturer's minimum design flow rate.

8.3.5.5 After switching on the device and fitting the face piece ask each test subject. Does the face piece fit?". If the answer is "Yes", continue the test. If the answer is "No", take the test subject off the panel and report the fact.

8.3.5.6 Ensure that the test subjects have no indication of the results as the test proceeds.

8.3.5.7 Ensure the test atmosphere is OFF.

8.3.5.8 Place the test subject in the enclosure. Connect up the sampling probe. Have the test subject walk at 6 km/h for 2 min. Measure the test substance concentration inside the face piece to establish the background level.

8.3.5.9 Wait for a stable reading to be obtained.

8.3.5.10 Turn the test atmosphere ON.

8.3.5.11 Instruct the test subject to continue to walk for a further 2 min or until the test atmosphere has stabilized

8.3.5.12 Whilst still walking, have the test subject perform the following exercises. Exercises b), c) and e) are performed with the supplementary fan operating such that an additional air velocity of 2 m/s is produced to impinge on the front, side and rear of the device in turn.

- a) walking without head movement or talking for 2 min,
- b) turning head from side to side (approximately 15 times), as if inspecting the walls of a tunnel for 2 min,
- c) moving head up and down (approximately 15 times), as if inspecting the ceiling and floor for 2 min,
- d) reciting the alphabet or an agreed text out loud as if communicating with a colleague for 2 min,
- e) walking without head movement or talking for 2 min.

8.3.5.13 *Record*

- a) chamber concentration, and
- b) the concentration in the breathing zone of the device over each exercise period.

8.3.5.14 Turn off the test atmosphere and when the test substance has cleared from the chamber remove the test subject.

8.3.5.15 Record the subjective assessment by each test subject of misting of the visor.

8.3.5.16 After use by each test subject the device shall be cleaned, disinfected and dried in accordance with the manufacturer's information supplied by the manufacturer before being used for its next inward leakage test.

8.3.5.17 Repeat the procedure with the other nine test subjects but for these the exercises b), c) and e) are performed with the additional air velocity of 2 m/s in one direction only. Ensure that each of the two devices specified in **8.3.3** is used for five test subjects. This will provide four sets of results for each of the directions for the additional air velocity as shown in Table 8 where x indicates that a test is performed and measurement made. Thus for the ten test subjects, four sets of results for each direction of air flow are obtained.

Table 8 Additional experimental plan for exercises b), c) and e)

(Clause 8.3.5.17)

Air flow direction	Exercises	Test subject									
		1	2	3	4	5	6	7	8	9	10
Front	b)	X	X			X			X		
	c)	X	X			X			X		
	e)	X	X			X			X		
Side	b)	X		X			X			X	
	c)	X		X			X			X	
	e)	X		X			X			X	
Rear	b)	X			X			X			X
	c)	X			X			X			X
	e)	X			X			X			X

8.3.6 Test Using Sulfur Hexafluoride as Test Substance

8.3.6.1 Apparatus

The general arrangement is shown in Fig. 3(a).

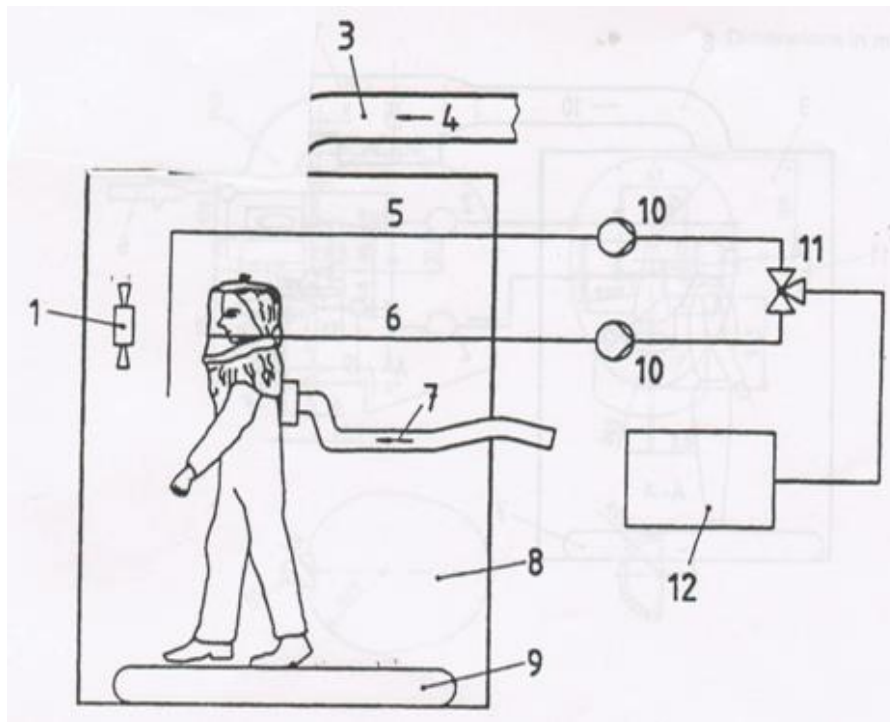

- | | | | |
|---|-----------------------|----|----------------------|
| 1 | Fan | 7 | Breathing air |
| 2 | Baffle | 8 | Enclosure |
| 3 | Duct | 9 | Treadmill |
| 4 | Air + SF ₆ | 10 | Pump |
| 5 | Enclosure sample | 11 | 3 port / 2 way valve |
| 6 | Breathing zone sample | 12 | Analyser |

FIG. 3(a) TEST ARRANGEMENT FOR DETERMINATION OF INWARD LEAKAGE BY THE SULFUR HEXAFLUORIDE METHOD

8.3.6.1.1 Test substance

Sulphur Hexafluoride

It is recommended that a test atmosphere concentration between 0.1 percent and 1 percent by volume should be used. Accurate determination of leakage with appropriate instruments are possible within the range from 0.01 percent to approximately 20 percent depending on the test concentration.

8.3.6.1.2 Detection means

The Concentration of sulfur hexafluoride in the test atmosphere and inside the facepiece of the device is measured and recorded by suitable instruments, ensuring that the response time for the detection system complies with 8.3.4.4.

8.3.6.2 Atmospheric conditions for test

The test is performed at ambient temperature and humidity.

8.3.6.3 Procedure

The procedure specified in 8.3.5 shall be used.

8.3.6.4 Calculation of inward leakage

The inward leakage (P) is calculated from measurements made over the last 100 s of each of the exercise periods to avoid carry over of results from one exercise to the other.

The value of P, expressed as a percentage, is calculated from the equation

$$P, \text{ percent} = \frac{c_2}{c_1} \times 100$$

Where,

C1 challenge concentration

C2 measured mean concentration in the breathing zone of the device.

Measurement C₂ is preferably taken via an integrating recorder.

8.3.7 Test using sodium chloride as test substance

8.3.7.1 Apparatus

The general arrangement is shown in Fig. 3 (b).

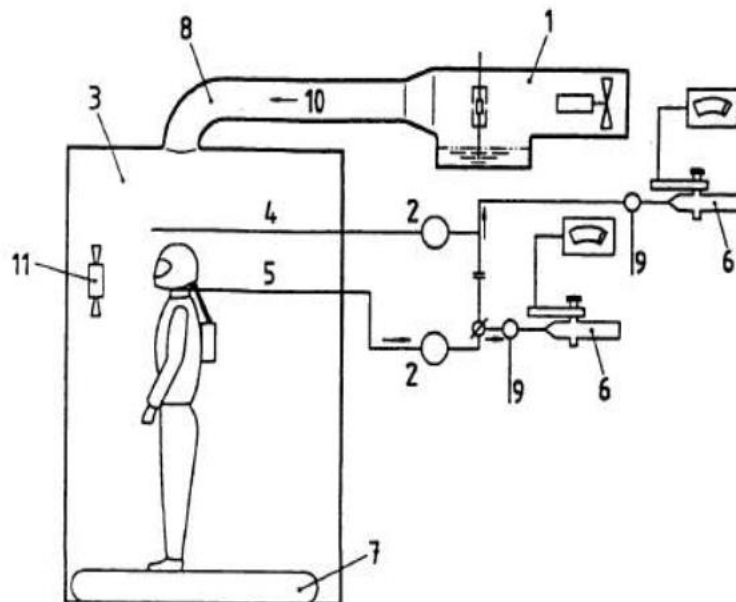

- | | | | |
|---|------------------|----|--------------------|
| 1 | Atomizer | 7 | Treadmill |
| 2 | Pump | 8 | Ducting and baffle |
| 3 | Enclosure | 9 | Additional air |
| 4 | Enclosure sample | 10 | Air + NaCl |
| 5 | Facepiece sample | 11 | Fan |
| 6 | photometer | | |

FIG. 3 (b) TEST ARRANGEMENT FOR DETERMINATION OF TOTAL INWARD LEAKAGE BY THE SODIUM CHLORIDE METHOD

8.3.7.1.1 Aerosol generator

The sodium chloride aerosol is generated from a 2 percent solution of reagent grade sodium chloride in distilled water. A single large collision atomizer is used, which requires an air flow rate of 100 l/min at a pressure of 7 bar. The atomizer and its housing are fitted into a duct through which a constant flow of air is maintained. It may be necessary to heat or dehumidify the air in order to obtain complete drying of the aerosol particles.

The mean sodium chloride concentration within the enclosure shall be (8 ± 4) mg/m³ and the variation throughout the effective working volume shall not be more than 10 percent. The particle size distribution shall be 0.02µm to 2 µm equivalent aerodynamic diameter with a mass median diameter of 0.6 µm.

8.3.7.1.2 *Flame photometer*

A flame photometer is used to measure the concentration of sodium chloride inside the face-piece. Essential performance characteristics for a suitable instrument are as follows:

- a) It should be specifically designed for the direct analysis of sodium chloride aerosol,
- b) It should be capable of measuring concentrations of NaCl aerosol between 5mg/m³ to 15 mg/m³
- c) The total aerosol sample required by the photometer should not be greater than 15 l/min
- d) The response time for the photometer, excluding the sampling system, should not be greater than 500 ms,
- e) The response to other elements needs to be reduced. This applies, particularly to carbon, the concentration of which will vary during the breathing cycle. The reduced response can be achieved by ensuring that the band pass width of the interference filter is not greater than 3 nm and that all necessary side-band filters are included.

8.3.7.1.3 *Sample tubes and pumps*

Sample tubes are of plastics tubing with a nominal inside diameter of 4 mm through which air is drawn. If no pump is incorporated into the photometer an adjustable flow pump is used to withdraw an air sample. Dependent on the type of photometer it may be necessary to dilute the sample with clean air. The pump shall be such that aerosol losses are minimized within the pump and changes in flow rate caused by changing pressure within the, sampling zone are also minimized.

NOTE — Some types of reciprocating diaphragm pumps have proved to be suitable.

The hood/chamber aerosol concentration is monitored during the tests using a separate sampling system, to avoid contamination of the facepiece sampling lines. It is preferable to use a separate flame photometer for this purpose.

If the second photometer is not available, sampling of the hood/chamber concentration using the separate sampling system and the same photometer may be made. However, time will then be required to allow the photometer to return to clean background.

8.3.7.2 *Atmospheric conditions*

The test is performed at ambient temperature and a relative humidity of not greater than 60 % in the enclosure when the atomiser is operating.

8.3.7.3 *Procedure*

The procedure specified in **8.3.5** shall be used.

8.3.7.4 *Calculation of inward leakage*

The leakage (P) is calculated from measurements made over the last 100 s of each of the exercise periods to avoid carry over of results from one exercise to another.

The value of P, expressed as a percentage, is calculated from the equation

$$P (\%) = \frac{C_2}{C_1} \times 1.25 \times 100$$

Where,

C₁ challenge concentration

C₂ measured mean concentration in the breathing zone of the device.

and

the factor 1.25 is included to allow for lung retention of sodium chloride. It has been derived on the assumption of an air flow rate of the device of 120 l/min and a wearer's breathing rate of 40 l/min.

8.4 Field of Vision

Refer standard IS 17274 (Part 11).

Field of vision is also assessed during the practical performance test. Results from the apertometer and the practical performance test are used to assess compliance with 7.3.3.2 by means of Table 9.

Table 9 Use of results from 8.4 and 8.16

(Clause 8.4)

Test	Possible results of test			
	1	2	3	4
Apertometer	√	√	X	X
Practical performance (8.16)	√	X	√	X
Meet field of vision requirements(8.3.3.2)	√	√	√	X
√ Pass X Fail				

8.5 Visor Robustness

Mount the complete assembled device on a dummy head supported in the same manner as worn. With the axis of the head form horizontal, impact the centre of the visor by a steel ball (22 mm diameter, mass approximately 44 g) allowed to fall from a distance of 130 cm. The impact shall be perpendicular to the surface of visor. Carry out the test with the air supply maintained at the manufacturer's minimum design flow rate.

Two visors shall be tested.

8.6 Breathing resistance

Fit the device on the Standard dummy head/torso and operate according to the information supplied by the manufacturer with fully charged batteries and clean filter(s). Where appropriate the fitting procedure described in Annex B.

Measure the breathing resistance with the device fitted to the artificial head or torso in an upright position, i.e. looking ahead.

Measure the exhalation resistance as a static pressure near the mouth of the dummy to which either a breathing machine adjusted to 25 cycles/min and 2.0 l/stroke or a continuous flow of 160 l/min is applied. Correct the flow rate to 23°C and 1 bar absolute. Refer Clause 6 of IS 17274 (Part 2).

8.7 Air Supply Flow Rate [Refer 8.2.4 and 8.3 of IS 17274 (Part 8)]

8.7.1 Principle

The flow of filtered air to the device is measured at zero back pressure and at ambient temperature. The initial flow rate and the flow rate after continuous operation for the manufacturer's stated design duration are measured.

8.7.2 Test Equipment

8.7.2.1 A Standard dummy head (or torso) fitted with mouth tube and pressure port at the mouth.

8.7.2.2 A suitable blower or suction device.

8.7.2.3 Control means for blower, such as a variable power regulator for the motor or an adjustable bleed in the air supply pipe work.

8.7.2.4 Suitable flowmeter, for example, calibrated from 50 l/min to 500 l/min.

8.7.2.5 Micromanometer, if used, capable of detecting a pressure difference of ± 0.01 mbar. An inclined liquid manometer or an electronic micro manometer is recommended.

8.7.2.6 Light weight plastics bag as shown in Fig. 4 and 5.

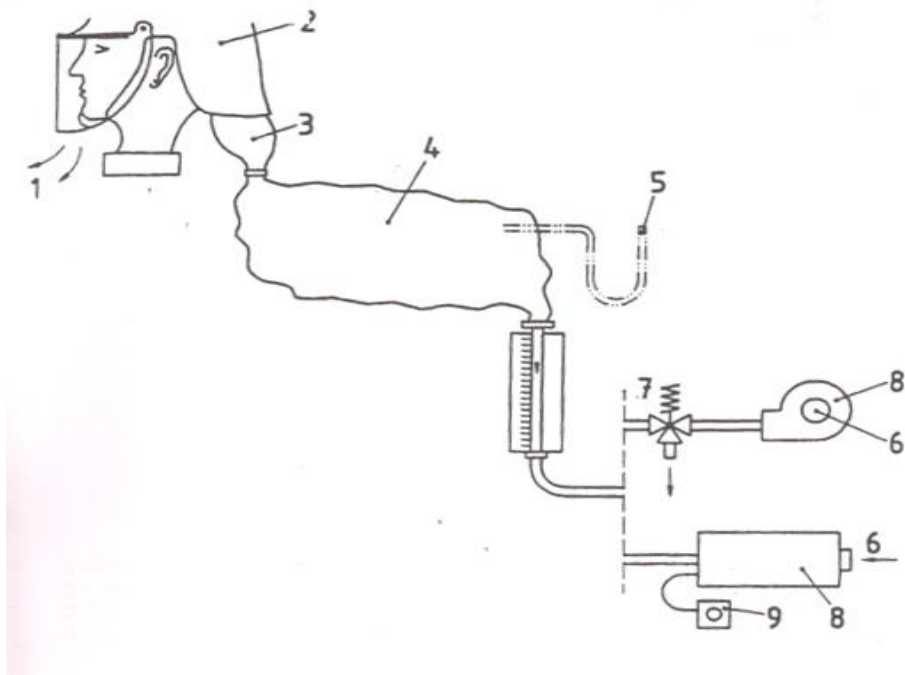

- | | | | |
|---|---------------------------|---|------------------------|
| 1 | Free flowing outlet | 6 | Inlet |
| 2 | Device under test | 7 | Variable bleed out |
| 3 | Adaptor | 8 | Blower |
| 4 | Lightweight plastic bag | 9 | Variable speed control |
| 5 | Micromanometer (optional) | | |

FIG. 4: TEST ARRANGEMENT FOR MEASUREMENT OF AIR SUPPLY FLOW RATE (HELMET/HOOD)

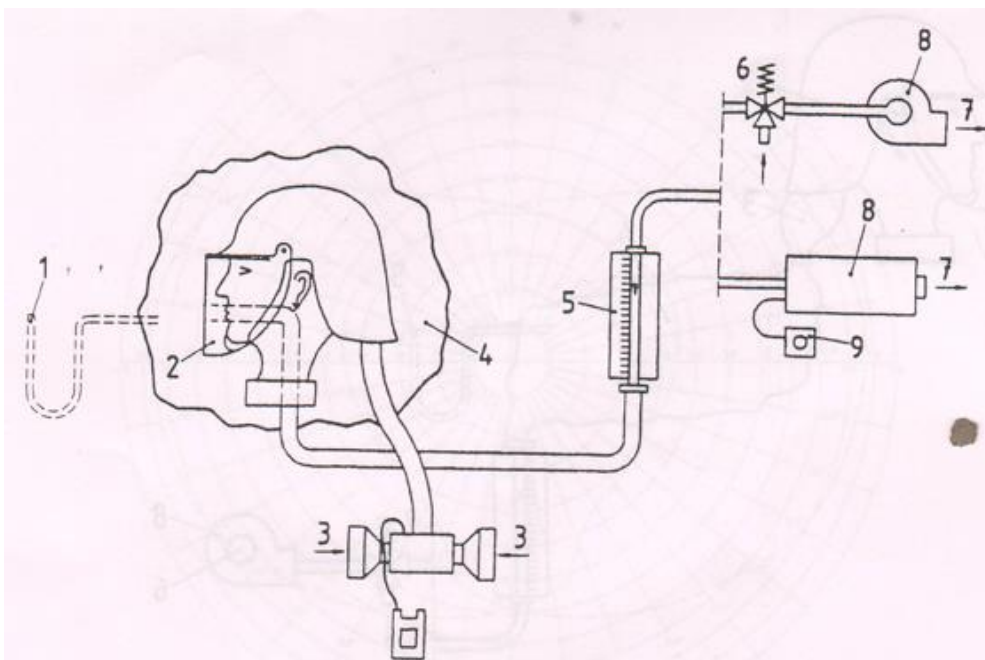

- | | | | |
|---|---------------------------|---|-------------------|
| 1 | Micromanometer (optional) | 6 | Variable bleed in |
|---|---------------------------|---|-------------------|

- | | | | |
|---|--------------------------|---|------------------------|
| 2 | Loose seal around face | 7 | Outlet |
| 3 | In | 8 | Suction device |
| 4 | Lightweight plastics bag | 9 | Variable speed control |
| 5 | Flowmeter | | |

FIG. 5: TEST ARRANGEMENT FOR MEASUREMENT OF AIR SUPPLY FLOW RATE (HELMET/HOOD WITH SEPARATELY MOUNTED TRUBO UNIT AND FILTERS)

8.7.3 Preparation of Device

Fit a fully charged battery and new filter(s) to the device.

In order to ensure a fully charged battery the following procedure is recommended. Operate the device normally until there is an audible decrease in air flow. Switch off the device and place the battery on charge in accordance with the manufacturer's information.

8.7.4 Fitting the Device into the Apparatus

Depending upon the design of the device, fit it into an appropriate apparatus. Examples are shown in Fig. 4, 5 or 6. Ensure that all joints are leaktight.

Where an adapter is used care should be taken to ensure it does not give rise to pressure/flow losses.

Devices with tight fitting neck seals need to be fitted to the dummy head with the neck seal adjusted as if the device were being worn and with the micro manometer connected to the breathing zone of the visor cavity in such a manner as to be free from velocity effects.

NOTE — It is possible that the flow past the pressure port can influence the recorded pressure.

8.7.5 Procedure: Initial flow rate

8.7.5.1 Devices tested according to Fig. 4 or Fig. 5

Switch on the device and adjust the blower (Fig. 4) or suction device (Fig. 5) until the plastics bag neither inflates nor deflates, i.e. zero back pressure.

The micromanometer should indicate zero pressure but observation of the plastics bag is often a more precise method of monitoring the pressure within such a flexible enclosure.

Record the reading of the flowmeter. Continue to ensure zero back pressure and repeat the flow measurement at intervals of 5 min until a total time of 30 min has elapsed.

Calculate the average of the seven flow measurements and report as the initial flow rate.

8.7.5.2 Devices tested according to Fig. 6

Switch on the device and adjust the suction means until the micromanometer indicates zero back pressure.

Record the reading of the flowmeter. Continue to ensure zero back pressure and repeat the flow measurement at intervals of 5 min until a total time of 30 min has elapsed.

Calculate the average of the seven flow measurements and report as the initial flow rate.

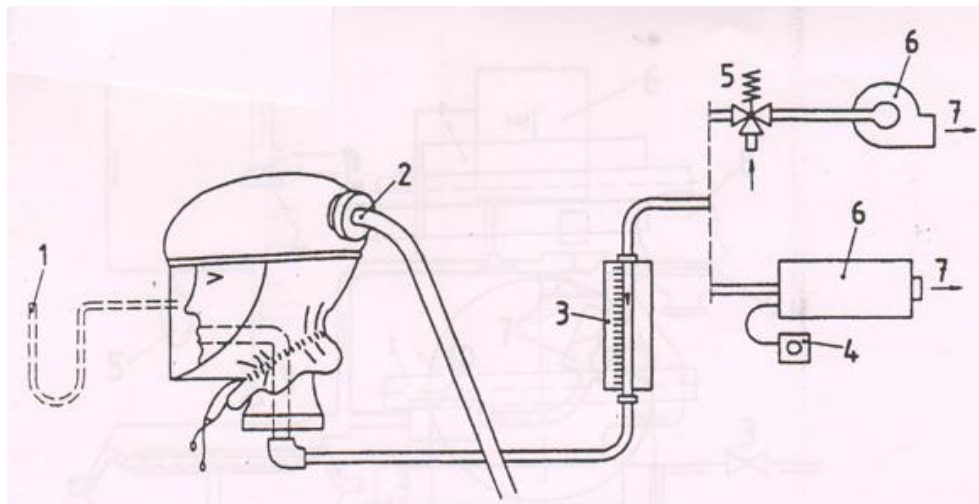

- | | | | |
|---|------------------------|---|-------------------|
| 1 | Micromanometer | 5 | Variable bleed in |
| 2 | Inlet(s) | 6 | Suction device |
| 3 | Flowmeter | 7 | Outlet |
| 4 | Variable speed control | | |

FIG. 6: TEST ARRANGEMENT OF AIR SUPPLY FLOW RATE
(HELMET/HOOD WITH TIGHT-FITTING NECK SEAL)

8.7.6 Procedure: Design duration

After measuring the initial flow rate as described in 8.7.5, disconnect the measuring apparatus from the device and switch off the blower/suction device.

Leave the device running whilst fitted to the dummy head for 1 h less than the manufacturer's design duration and then reconnect the measuring apparatus as in Fig. 4, 5 or 6 as appropriate.

Measure and-record the flow rate as described in 8.7.5 at a total elapsed time (including the first 30 min for initial flow rate measurement) equal to the manufacturer's design duration.

8.8 Clogging

The test equipment and the test atmosphere shall be that described in IS 15322 with the following modifications. At least the filters and the fan shall be in test atmosphere for the test. New filters and a fully charged battery shall be fitted to the device before starting the clogging procedure. The complete device fitted with a fully charged battery and clean filter(s) shall be tested on a standard dummy head connected to a breathing machine adjusted to 30 l/min (20 cycles/min, 1,5 l/stroke, sinusoidal breathing pattern).

Operate the device in a dolomite dust concentration of $(400 \pm 100) \text{ mg/m}^3$ until the product of dust concentration and the testing time is:

- a) Particle filter only

TH1P	400	$\text{mg}\cdot\text{h}/\text{m}^3$
TH2P	400	$\text{mg}\cdot\text{h}/\text{m}^3$
TH3P	200	$\text{mg}\cdot\text{h}/\text{m}^3$

e.g. for TH1P the product may be $400 \text{ mg}/\text{m}^3$ for 1 h or $300 \text{ mg}/\text{m}^3$ for 1,33 h,

- b) Gas vapour filter only

There is no clogging requirement,

- c) Combined filters

TH1(Gas)P $200 \text{ mg}\cdot\text{h}/\text{m}^3$

TH2(Gas)P 200 mg•h/m³

TH3(Gas)P 100 mg•h/m³

Where gas = gas component of classification,

- d) Special filters
100 mg•h/m³.

At the end of the test, take the device out of the dust chamber, clean on the outside if necessary and test for flow rate in accordance with 8.7 and for the penetration requirements at this flow rate in accordance with 8.12.2, except:

- a) That conditioning is not required.
b) Only the Penetration test of equivalent IS shall be performed.

8.9 Resistance to Collapse of Breathing Hose

8.9.1 Principle

The manufacturer's minimum design air flow is passed through the breathing hose which is subjected to a specified load. The change in air flow is measured.

8.9.2 Apparatus

Two circular plates 100 mm in diameter and thickness at least 10 mm. One plate is fixed and the other is capable of moving at right angles to the plane plates. The moving plate is capable of being loaded to ensure a total force of 50 N can be applied between the plates (*see* Fig. 7)

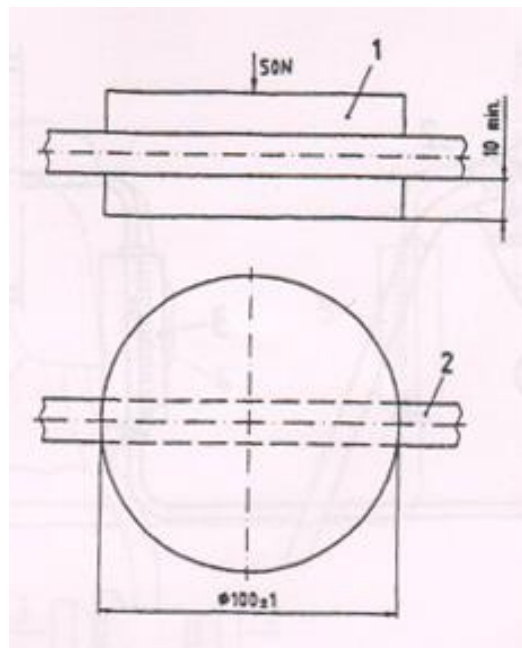

1 Movable plate

2 Breathing hose

FIG. 7 TEST ARRANGEMENT FOR MEASUREMENT OF RESISTANCE TO
COLLAPSE OF BREATHING HOSE

8.9.3 Procedure

Measure the flow in accordance with 8.7 and record this flow. Place the breathing hose centrally between the two plates and pass the manufacturer's minimum design air flow rate through the hose by means of the turbo unit.

Apply the test force of 50 N (which includes that due to the moveable plate itself) to the hose and measure the air flow in accordance with 8.7

8.10 Strength of Hose and Couplings and of Connection Between Hood and Breathing Hose

Suspend the breathing hose and couplings and apply the appropriate force specified in Table 2 for 10 s to the free end.

Suspend the hood and the breathing hose and apply the appropriate force specified in Table 2 for 10 s to the free end.

Where multiple hoses are fitted to the device, apply the appropriate load to each hose.

Report any damage or failure.

8.11 Mechanical Strength of Filters (Refer Clause 6.8 IS 17274 Part 6)

8.11.1 Test Equipment

The apparatus as shown schematically in Fig. 8, consists of a steel case (K) which is fixed on a vertically moving piston (S), capable of being lifted up 20 mm by a rotating cam (N) and dropping down on to a steel plate (P) under its own mass as the cam rotates. The mass of the steel case shall be greater than 10 kg, and the mass of the base of the equipment shall be at least ten times as much as the case, or the equipment shall be bolted to the floor.

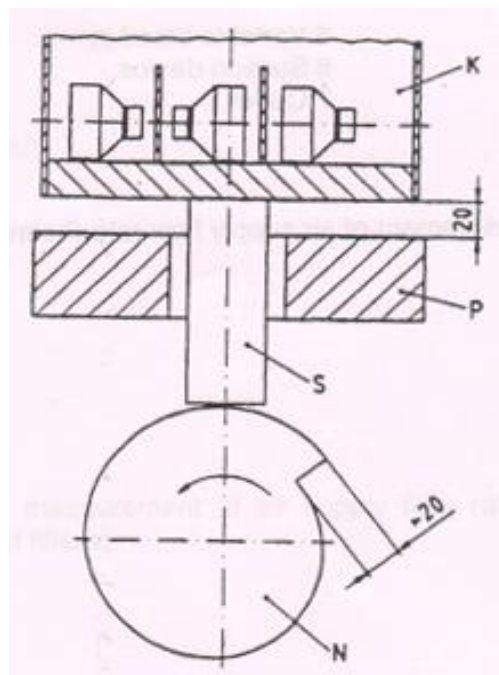

- K Steel case
- N Rotation cam
- P Steel plate
- S Vertically moving piston

FIG. 8 TEST ARRANGEMENT FOR ASSESSMENT OF MECHANICAL STRENGTH

8.11.2 Test Procedure

The filters shall be tested as received, removed from their packing but still sealed.

The test rig is operated at the rate of approximately 100 rotations per min for approximately 20 minutes for a total of 2000 rotations.

The filters shall be placed on their sides in the case (K) so that they do not touch each other during the test, allowing 6 mm horizontal movement and free vertical movement. After testing, any loose material that may have been released from the filter shall be removed prior to the performance testing

8.12 Filters

8.12.1 General

When a single filter of a multiple filter device is tested separately the initial air flow measured as per the procedure described in 8.7.5 shall be proportioned equally. If, however, the single filter is intended to be used alone, then

the full initial air flow as measured as per the procedure described in **8.7.5** shall be used for testing. These are the appropriate test flow rates.

Three filters shall be tested for each aerosol. The filters shall be subjected to conditioning as described in **8.1.2**, and then to mechanical strength testing as described in **8.11**, prior to aerosol testing.

Four filters shall be tested for each gas. Two filters shall be subjected to the mechanical strength testing as described in **8.11** prior to gas testing. The two further filters shall be subjected to conditioning as described in **8.1.2**, and then to mechanical strength testing as described in **8.11**, prior to gas testing.

The filters shall remain in their smallest packaging or seal during conditioning and then all packaging and seals shall be removed prior to aerosol or gas testing.

8.12.2 Particle Filter Efficiency (Refer Clause 7.2.2 & 7.2.3 of IS 17274 Part 3)

Filters for use against solid and liquid aerosols shall be tested against sodium chloride and paraffin oil. Filters shall be tested using the penetration and exposure tests, and if re-usable the storage test, described in IS 17274 Part 4 after conditioning in accordance with **8.11**, except:

- the test flow rate shall be that defined in **8.12.1**;
- for the exposure test, the specified mass of test aerosol shall be calculated as follows:

Exposure per filter (mg) = $(C \times Q \times t)$, where

C (mg/m³) is the concentration in the working environment fixed at 8 mg/m³;

Q (m³/h) is the initial flow rate determined according to **8.12.1**, divided by the number of filters fitted per device;

t (h) is the duration in the working environment fixed at 8 h.

- where the paraffin oil filter penetration test is used the aerosol concentration shall be (20 ± 10) mg/m³.

8.12.3 Protection capacity of gas filters, special filters, AX filters, SX filters and combined filters

8.12.3.1 General

All performance tests shall be conducted so that the test gas or air will pass through the filter horizontally.

If the gas filter is combined with a particle filter, the combined filter shall be submitted for the penetration test for the particle filter as described in **8.12.2** in addition to the test described in **8.11**, **8.12.3.2**, **8.12.3.3**, **8.12.3.4** and **8.12.3.5**, as appropriate.

Protection capacity (minimum breakthrough time) is measured at the appropriate test flow rate as defined in **8.12.1** and at (70 ± 2) % relative humidity at (20 ± 1) °C under the conditions given in tables 10, 11 or 12 or clause **8.12.3.5**.

8.12.3.2 Protection capacity of A, B, E and K filters

Any convenient experimental method may be employed for obtaining the specified influent concentration, and the measuring the effluent concentration, provided they conform to the following limits:

Influent concentration: within ± 10 percent of specified value,

Effluent concentration: within ± 20 percent of specified valve.

The recorded breakthrough time shall be adjusted if necessary by simple proportion to conform with the specified influent concentration.

8.12.3.3 Protection capacity of special filters

Special filters shall be tested under conditions given in Table 11.

8.12.3.4 Protection capacity of AX filters

AX filters shall be tested under the conditions given in Table 12.

8.12.3.5 Protection capacity of SX filters

Protection capacity (sorption and desorption) of SX filters shall be assessed using the following procedures.

- a) Sorption

Use as test gas/gases those against which the filters are intended to give protection.

The test gas concentration shall be 0.5 percent by volume.

The breakthrough concentration shall be 5 ml/m³.

b) Desorption

Load the filters with the test gas for 10 min under the same conditions as for the sorption test.

After dosing, the filters shall be sealed and stored at approximately 20 °C for a period of 2 to 4 days.

After storage, pass clean air, at the appropriate test flow rate as specified in **8.12.1** at (20 ± 1) °C and (70 ± 2) percent RH through the filter for a period of 2 h. The concentration of the test gas in the effluent air shall be monitored during the desorption test.

Table 10 Test conditions for A, B, E, K filters

(Clause 8.12.3.1)

Filter type and class	Test gas	Breakthrough concentration		
		percent by volume	mg/l	ml/m ³
A1	Cyclohexane (C ₆ H ₁₂)	0.05	1.8	10
	Chlorine (Cl ₂)	0.05	1.5	0.5
B1	Hydrogen sulfide(H ₂ S)	0.05	0.7	10
	Hydrogen cyanide (HCN)	0.05	0.6	10(*)
E1	Sulphur dioxide (SO ₂)	0.05	1.3	5
K1	Ammonia (NH ₃)	0.05	0.4	25
A2	Cyclohexane (C ₆ H ₁₂)	0.1	3.5	10
	Chlorine (Cl ₂)	0.1	3.0	0.5
B2	Hydrogen sulfide(H ₂ S)	0.1	1.4	10
	Hydrogen cyanide (HCN)	0.1	1.1	10(*)
E2	Sulphur dioxide (SO ₂)	0.1	2.7	5
K2	Ammonia (NH ₃)	0.1	0.7	25
A3	Cyclohexane (C ₆ H ₁₂)	0.5	17.5	10
	Chlorine (Cl ₂)	0.5	15.0	0,5
B3	Hydrogen sulfide(H ₂ S)	0.5	7.1	10
	Hydrogen cyanide (HCN)	0.5	5.6	10(*)
E3	Sulphur dioxide (SO ₂)	0.5	13.3	5
K3	Ammonia (NH ₃)	0.5	3.5	25

(*) C₂N₂ may sometimes be present in the effluent air. The total concentration of (C₂N₂ + HCN) shall not exceed 10 ml/m³ at break through

Table 11 Test Conditions for Special Filters

(Clause 8.12.3.1 and 8.12.3.3)

Filter type	Test substance	Test substance concentration in air		Breakthrough concentration
NOP	Nitric oxide(NO)*	0.25 % by volume	3.1 mg/l	5 ml/m ³ **
	Nitrogen dioxide(NO ₂)*	0.25 % by volume	4.8 mg/l	5 ml/m ³ **
HgP	Mercury vapour(Hg)	1.6 ml/m ³	(13 ± 1)mg/m ³	0.1 mg/m ³

* The gas shall be tested at least 95 % pure. This is probably best obtained as compressed gas in cylinders

** Both NO and NO₂ may be present in the effluent air. The total concentration of (NO+NO₂) shall not exceed 5 ml/m³.

Table 12 Test conditions for AX filters

(Clauses 8.12.3.1 and 8.12.3.4)

Test substance	Test substance concentration in air		Breakthrough concentration ml/m³
Dimethyl ether (CH ₃ -O-CH ₃)	0.05 percent by volume	0.95 mg/l	5
Isobutane (C ₄ H ₁₀)	0.25 % by volume	6.0 mg/l	5

8.13 Noise level

8.13.1 Principle

The device is worn by a test subject and the noise level in dB (A) measured at the test subject's ear.

8.13.2 Apparatus

8.13.2.1 Microphones capable of being fitted at the test subject's ears

8.13.2.2 Sound level meter of type 1 or 2 as specified in IS 15575 (Part 1).

8.13.3 Procedure

8.13.3.1 Calibrate the sound level meter in accordance with the manufacturer's instructions.

8.13.3.2 Ensure that the device to be tested is equipped with a fully charged battery and one of the filter types designed to be used with the device.

8.13.3.3 Fix the microphones to the test subject at the centres of each of the external ears and levels with the tragus.

8.13.3.4 Have the test subject done the device.

8.13.3.5 Switch on the power on the device and measure, in succession, the sound pressure level at each of the two ears with the sound level meter set to indicate "A" weighting frequency characteristics.

8.13.3.6 Check that the background noise level in the test room is not less than 10 dB (A) lower than that measured for the device and adjust the background level as necessary to meet this condition.

8.13.3.7 Report the higher of the results as the noise generated by the devices as experienced by the wearer.

8.13.3.8 Repeat the procedure for the complete set of filter types designed to be used with the device.

8.14 Carbon Dioxide Content of the Inhalation Air (Refer Clause 7 IS 17274 Part 9)

8.14.1 Principle

The device is fitted to a Standard dummy head/torso and operated at the design flow rate. Breathing air is supplied at a specified rate from a breathing machine and the inhaled air is analyzed for carbon dioxide content.

8.14.2 Test Equipment

A typical test arrangement using a single cylinder breathing machine is shown in fig. 9

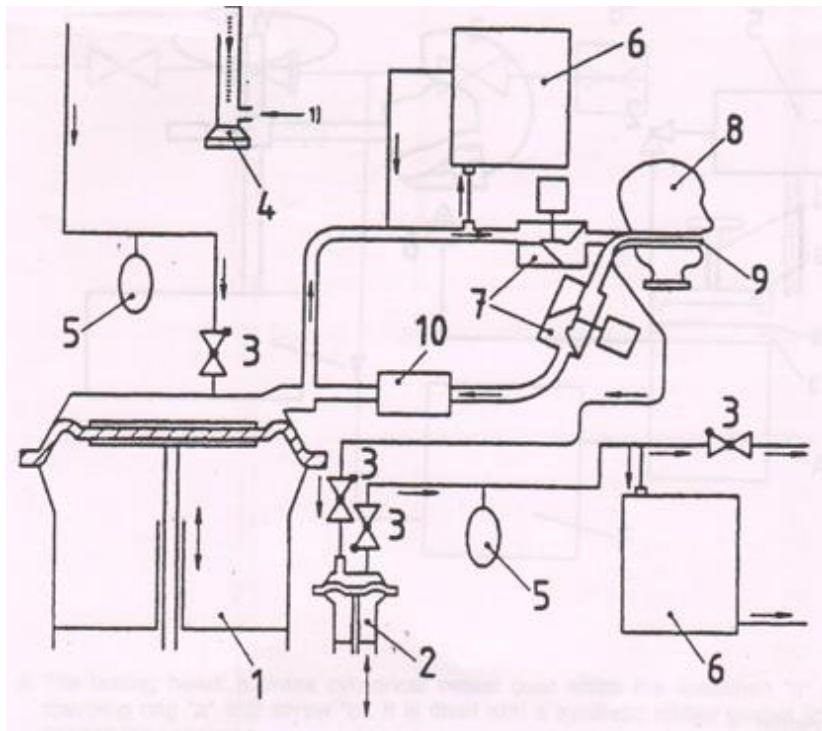

- | | | | |
|----|-------------------|----|----------------------------------|
| 1 | Breathing machine | 6 | Carbon dioxide analyser |
| 2 | Auxiliary lung | 7 | Solenoid valve |
| 3 | Non-return valve | 8 | Dummy head |
| 4 | Flowmeter | 9 | Sampling tube for inhalation air |
| 5 | Compensator | 10 | Carbon dioxide absorber |
| 1) | Carbon dioxide | | |

FIG. 9: TEST ARRANGEMENT FOR DETERMINATION OF CARBON DIOXIDE CONTENT OF INHALATION AIR USING A SINGLE CYLINDER BREATHING MACHINE

8.14.2.1 Breathing machine and associated equipment with solenoid valves controlled by the breathing machine.

8.14.2.2 Auxiliary lung.

8.14.2.3 Standard head/torso.

8.14.2.4 Carbon dioxide flowmeter, analysers and absorber. The carbon dioxide absorber is necessary to prevent buildup of carbon dioxide in the test equipment circuit.

8.14.2.5 Where appropriate means for setting up and testing hooded devices which do not have a head harness and which seal around the neck. (Refer Annex B).

8.14.3 Procedure

- a) Adjust the breathing machine to give air at 25 cycles/min and 2.0 l/stroke.
- b) Adjust the carbon dioxide supply into the breathing machine to 2.5 l/min via a control valve, a flowmeter, a compensating bag and non-return valves.
- c) Check the carbon dioxide content of the exhaled air and adjust as necessary to give 5 percent by volume measured on a dry basis. Ensure that the sample drawn off for analysis is returned to the test circuit to maintain the correct volumetric flow.
- d) Fit the device to the Standard head/torso and operate at the manufacturer's minimum design flow rate.
- e) Drawn off a sample of the inhaled air during the inhalation phase by the auxiliary lung set at a rate of 100ml displacement/ stroke.
- f) Measure the carbon dioxide concentration in the sample by means of analyser. Continue the test until a steady value is obtained. Record this value as the uncorrected level of carbon dioxide in the inhaled air.
- g) Measure the ambient carbon dioxide level 1m in front of and level with the tip of the nose of the dummy head. Take the measurement once a stabilized level for carbon dioxide in the inhalation air has been attained.
- h) Alternatively, measure the ambient level at the sampling tube with carbon dioxide supply turned off. The reference level shall be below 0.1 percent.
- i) Subtract the laboratory ambient carbon dioxide level from the measured value in the inhaled air.

8.14.4 Procedure for hooded devices which seal around the neck and which may or may not incorporate a head harness. The procedure given in Annex B shall be used.

8.14.5 Report

Report the carbon dioxide content of the sample when a steady value has been obtained.

8.15 Resistance to Flame (Refer Clause 6.2.4 (IS 17274 part 10))

8.15.1 Principle

The facepiece or other component of the device is mounted either on a metallic dummy head (facepiece) or in a suitable manner on a rotating support arm and passed through a flame and the effects of the flame on the device observed.

8.15.2 Apparatus

8.15.2.1 A metallic dummy head mounted on a support which enables it to be rotated to describe a horizontal circle (*see* fig. 10). A facility to enable attachment of any other parts of the device to the rotating support.

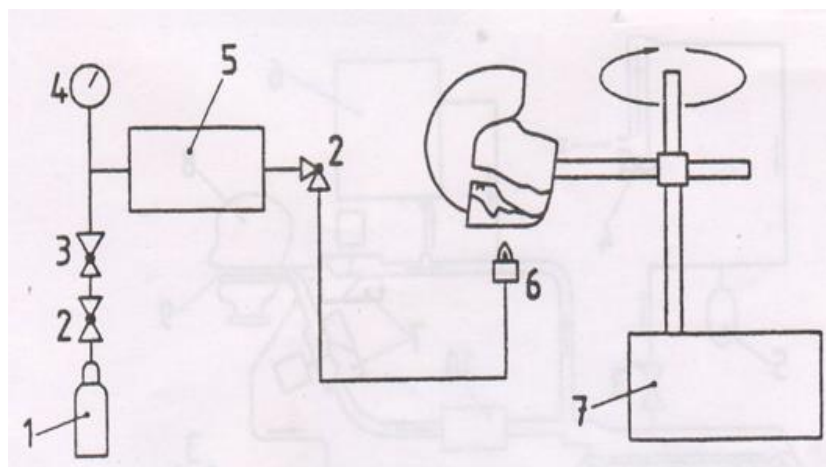

1 Propane cylinder

5 Flame arrester

2	Valve	6	Burner
3	Pressure reducer	7	Rotation motor and speed control
4	Pressure gauge		

FIG. 10: TEST ARRANGEMENT FOR ASSESSMENT OF FLAMMABILITY

8.15.2.2 Gas supply rig consisting of a propane storage tank with flow control valve and pressure gauge, flashback arrester and a propane burner. The burner shall be adjustable in height.

8.15.2.3 A thermocouple probe of 1.5 mm diameter.

8.15.3 *Procedure*

8.15.3.1 *Facepiece*

Fit the device to the dummy head and ensure that a speed of rotation of (60 ± 6) mm/s can be obtained.

8.15.3.2 *Other components*

Fit the component to the support arm at such a radius that a speed of rotation of (60 ± 6) mm/s can be obtained.

8.15.3.3 Rotate the head and device or component so that it is over the burner. Adjust the position of the burner such that the distance between the top of the burner and the lowest part of the device which is to pass through the flame is (20 ± 2) mm. Rotate the head away from the burner.

Ignite the gas at the burner. Ensure that the burner air vent is fully closed and adjust the flow control valve to give a flame height of approximately 40mm above the burner top. These settings shall be adjusted to give a flame temperature of (800 ± 50) °C at a point (20 ± 2) mm above the burner top.

Pass the device or component once through the flame at the set speed of (60 ± 6) mm/s.

Repeat the test to enable an assessment to be made of all materials on the exterior of the device. Any one component shall be passed through the flame once only.

8.15.4 *Assessment and Test Report*

Examine the device or component after it has passed through the flame and report whether it continues to burn.

8.16 *Practical Performance*

Refer Clause **6.1**, **6.2**, **6.3**, **6.4** & **6.5** from IS 17274 (Part 7).

8.16.1 *Principle*

Test subjects wearing the device carry out activities in simulation of practical use. The test subjects are then asked to assess subjectively the device for ease to use.

8.16.2 *Test Subjects*

Two test subjects are used, the medical history of whom is known to be satisfactory. The necessity of a medical examination before, and supervision during, the test is decided by the test officer.

8.16.3 *Test Conditions*

The test is carried out in an atmosphere of (20 ± 5) °C and a relative humidity of (60 ± 15) percent. The noise level in the area shall not be greater than 75 dB (A). The actual conditions shall be recorded.

8.16.4 *Procedure*

Two devices shall be used in the test each fitted with fully charged battery (s) and clean filters.

Each test subject is asked to use the device in accordance with the information supplied by the manufacturer and the following sequence of activities is carried out in a total time of 30 min.

The order in which the activities are done is at the discretion of the test officer.

- a) walking on the level at regular rate of 6 km/h for 10 min,
- b) walking on the level with headroom of (1.3 ± 0.2) m for 5 min.
- c) crawling on the level with headroom of (0.7 ± 0.05) m for 5 min,
- d) filling a small basket with suitable 12 mm chipping from a hopper which stands 1.5 high and has an opening at the bottom to allow the contents to be shoveled out and a further opening at the top where the chippings may be returned. The test subject stoops or kneels as desired and fills the basket with chippings. The test subject then lifts the basket and empties its contents back into the hopper. The procedure is repeated 19 times in 10 min.

The test subject then removes the device and the procedure is repeated for the other test subject wearing the other device.

8.16.5 *Test report*

- a) After completing the procedure, each test subject is asked to comment on the following:
- b) head harness comfort,
- c) harness or belt comfort,
- d) ease of donning and doffing
- e) security of fastenings and couplings
- f) accessibility of any controls fitted,
- g) clarity and field of vision including misting,
- h) speech transmission,
- j) the balance of the device in use,
- k) any inadvertent operation of the “on-off” or of any means of changing flow rate or classification,
- m) whether the flow rate and distribution of air cause any stress or discomfort,
- n) ease of operation of the checking facilities,
- p) the operation of the warning facility,
- q) freedom of head movement with respect to breathing hose(if fitted),
- r) any other aspect on which the wearer may wish to comment.

8.17 Material Porosity

8.17.1 *Principle*

A specified air pressure is applied to the material which is wetted by a liquid and has a film of the same liquid applied to its upper surface. If a bubble appears on the upper surface the material is rated as porous for the purposes of determining which method is to be used for the determination of inward leakage.

8.17.2 *Apparatus*

A suitable form of apparatus is shown in Fig. 11.

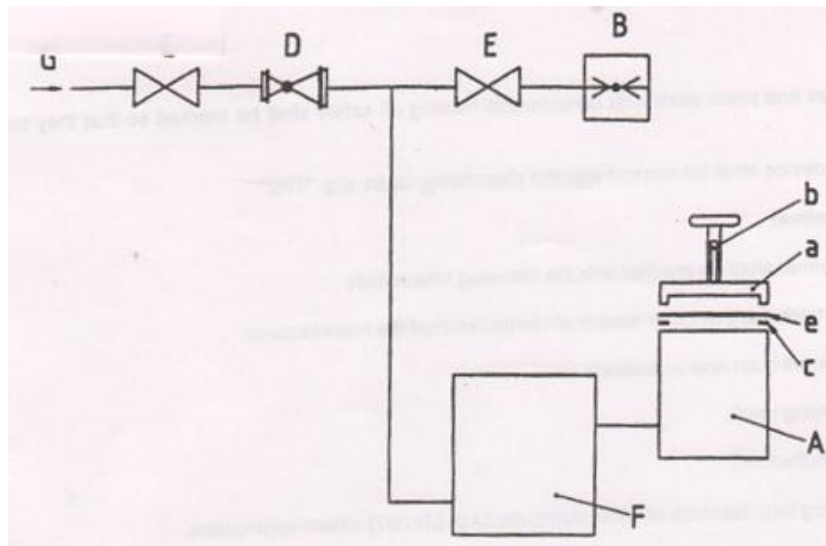

- A The testing head: a brass cylindrical vessel over which the specimen “d” is clamped by a clamping ring “a” is fitted with a synthetic rubber gasket “c” to make a seal against the specimen.
- B Pressure measuring device.
- C A stop-valve which serves to direct air to the testing head.
- D A variable blow valve set to give the required rate of rise of pressure in A.
- E A stop-valve which directs air to the pressure measuring device.
- F Air reservoir of about 2.5 litre capacity connected to A. This ensures that the flow rate of air necessary to maintain the required rise of pressure is so large that the loss of air through the fabric when bubbling begins will not seriously reduce the rate of rise of pressure.
- G The air supply.

NOTE — This diagram shows one possible way of constructing the apparatus

FIG. 11: TEST ARRANGEMENT FOR ASSESSMENT OF POROSITY OF HOOD MATERIALS

8.17.2.1 Testing head

A testing head is consisting of a cylindrical vessel over which the test specimen is clamped by a clamping ring and screw. The head is fitted with a synthetic rubber gasket to make a seal against the test Specimen.

8.17.2.2 Test liquid

Water in which a wetting agent (softener or washing-up liquid) is dissolved to form a solution by adding a few drops to one litre of water.

8.17.2.3 Pressure measuring device

8.17.2.4 Air supply and control valves

8.17.3 Testing Atmosphere

Carry out the test at normal ambient temperature and relative humidity.

8.17.4 Preparation of Test Specimens

Take the test specimens from different places in the device in order that an assessment can be made of all materials and seams.

Condition the test specimens for at least 24 h at normal ambient temperature and relative humidity.

8.17.5 Procedure

Soak the conditioned test specimen under approximately 15 mm of test liquid for a period of not less than 3 min. Remove the test specimen from the test liquid and clamp it in the testing head. Pour a few milliliters of test liquid onto the surface of the test specimen.

Apply pressure to the undersurface of the test specimen until bubbles escape, up to a maximum of 100 mbar. Note whether any bubbles escape over the upper surface of the test specimen indicating that the material is porous.

Repeat the test with the other test specimens.

8.17.6 Report

Report whether or not the fabric has been assessed as porous.

9 MARKING

9.1 General

Sub-assemblies and piece parts with considerable bearing on safety shall be marked so that they can be identified

The complete device shall be marked with the class designation, for example, "TH2".

9.2 Hood or Helmet

The hood or helmet shall be marked with the following information: the name, trademark or other means of identification of the manufacturer,

- a) The size if more than one is available,
- b) Type-identifying mark,
- c) Year of manufacture,
- d) The marking requirements of other standards where appropriate.

9.3 Turbo-Unit and Battery Casing (if separate from the turbo-unit)

Each shall be marked with the following information:

- a) The name, trademark or other means of identification of the manufacturer,
- b) Type-identifying mark,
- c) If appropriate, an indication that the device is intrinsically safe for use in explosive atmospheres and reference to IS/IEC 60079 (Part 11)
- d) The year of manufacture,
- e) The number of this Indian Standard,
- f) The sentence "see information supplied by the manufacturer" in the official language(s) of the country of destination, or appropriate pictogram.

9.4 Filters

9.4.1 General

9.4.1.1 All filters except unencapsulated filters shall be marked with:

- a) the appropriate filter type and colour code

	<i>Type</i>	<i>Colour</i>
Particle Filters		
	P	White
Gas and Combined Filters		
	AA	Brown
	B	Grey
	E	Yellow
	K	Green
	AX	Brown
	SX	Violet
	NO P	Blue- White

Hg P

Red-white

or combinations of the above. Where a gas filter is combined with a particle filter it shall additionally carry a white peripheral band.

If the marking is not directly printed on the filter body, it shall be on a peripheral band of the appropriate colour code affixed to the filter body. In this case, the colour of the body shall not be considered to be the colour code.

Silver or light metal colour shall not be regarded as white.

- b) The number of this Indian Standard ,
- c) The year and month of expiry of shelf life or equivalent,
- d) The manufacturer's name, trade mark or other means of identification,
- e) The sentence "see information supplied by the manufacturer" in the official language(s) of the country of destination or the appropriate pictogram,
- f) Type –identifying mark.

9.4.1.2 Unencapsulated filters shall be marked with:

- a) The appropriate filter type ,
- b) Type –identifying mark ,
- c) All other information specified in **9.4.1.1** shall be included in or on the smallest packages.

9.4.2 Particle Filters

All particle filters shall be marked as follows:

- a) "NR" if the filter is limited to single shift use only, or
- b) "R" if the filter is re-usable.

The marking of "NR" or "R" shall follow the marking of "P", separated by a single space.

Filters which do not pass the paraffin oil test shall be clearly marked with either "for use against solid and water based aerosols only" or "S". If only the "S" appears on the filter then the words "for use against solid and water based aerosols only" shall be included in or on the smallest packages. All other particle filters shall be marked with the letters "SL".

9.4.3 Gas and Combined Filters

- a) all AX filters shall be marked "for single use only",
- b) all SX filters shall be marked with the name (s) of the chemicals against which the filter has been tested,
- c) all NOP filters shall be marked "for single use only",
- d) all HgP filters shall be marked with the sentence "Maximum use time 50 hours".

9.4.4 Combined Filters

Combined filters shall be marked as specified in **9.4.1**, **9.4.2** and **9.4.3** as appropriate.

9.5 Filter or Filter Package — The filter or the filter package box shall be marked with the following information, unless it is already on the filter:

- a) The appropriate filter type and colour code, particle filter re-usability and option as given in **9.4.1**, **9.4.2** and **9.4.3**.
- b) The number of this Indian standard ,
- c) The year and month of expiry of shelf life or equivalent,
- d) The manufacturer's name , trade mark or other means of identification ,
- e) The sentence "see information supplied by the manufacturer" in the official language (s) of the country of destination , or the appropriate pictogram,
- f) Type –identifying mark,
- g) The manufacturer's recommended conditions of storage (at least the temperature and humidity).

The information specified in “c”, “f” and “g” shall be visible without opening the package.

9.6 Packages

All packages shall be marked with the following or it shall be visible without opening the packages:

- a) the manufacturer’s recommended conditions of storage (at least the temperature and humidity),
- b) the sentence “See information supplied by the manufacturer” in English language or the appropriate pictogram,
- c) an indication of the contents.

10 INFORMATION SUPPLIED BY THE MANUFACTURER

10.1 Complete Device

10.1.1 Information in the official language (s) of the country of destination shall accompany every device on delivery, enabling and qualified persons to use it.

It is suggested that detailed maintenance and storage information should be made available separately from the information supplied by the manufacturer.

10.1.2 The information shall comprise the range of application ‘information concerning correct fitting, care, maintenance, battery charging and storage. This shall include the range of operating and storage temperatures and humidities. Attention shall be drawn to possible incorrect use and, where appropriate, the possibility of looped hoses and /or cables becoming caught up. A warning should also be given that at very high work rates the pressure in the device may become negative at peak inhalation flow.

10.1.3 The information shall describe precisely and comprehensibly which permissible combinations of components are to be used for a specific type and class of device.

If helpful, illustrations, part numbers, marking may be added.

The information shall in addition give detailed advice on the use and replacement of filters.

10.1.4 If the equipment is of a type which may have problems where high wind velocities exist a warning shall be given.

10.1.5 A warning shall be given that in the power –off state little or no respiratory protection is to be expected, and that this is considered to be an abnormal situation. A warning should also be given that in the “power –off” state a rapid build-up of carbon dioxide and depletion of oxygen within the hood may occur.

10.1.6 Attention should be drawn to the fact that if the device is permissible for use in an explosive atmosphere it is marked as such.

10.1.7 The information shall state the manufacturer’s design duration and minimum design flow rate, and include details of how the flow rate can be checked prior to each use.

10.1.8 Where a warning device in accordance with 6.7 is provided the information shall describe a method for checking the correct functioning of the warning device.

10.1.9 Warning that the device is unsuitable for use in oxygen deficient atmospheres.

10.1.10 In the case of hoods or helmets, which do not include an integrated turbo unit, a warning that filters shall only be fitted to the turbo and not directly to the helmet/hood.

NOTE — If the turbo unit is integrated into the hood or helmet, then this warning is not required.

10.1.11 A warning that the user should not confuse the markings on a filter relating to any standard other than IS....(PAPR std no) with the classification of this device when used with this filter.

10.1.12 The complete device shall be marked with the class design, e.g. “TH2”.

10.2 Filters

The information given in **10.1.3** and information on application, fitting, care, range of storage conditions (at least the temperature and humidity) and possible incorrect use shall be included in the smallest commercially available package.

For single-shift use particle filters (marked “NR”), a warning shall be given that the filter shall not be used for more than one shift.

ANNEX A

(Clause 2)

LIST OF REFERRED STANDARDS

<i>IS No.</i>	<i>Title</i>
IS 8347 : 2008	Glossary of terms relating to relating to respiratory protective devices.
IS 14166 : 1994	Respiratory protective devices-Full Face masks —Specification
IS 14746 : 1999	Respiratory protective devices-Half face masks — Specification
IS 15322 : 2003	Particle Filters used in Respiratory Protective Equipment — Specification
IS 14138 (Part 1)	Respiratory protective devices-Threads for facepieces, Part 1 Standard thread connection.
IS 5983 : 1980	Eye protector(<i>first revision</i>)
IS 2925 : 1984	Specification for Industrial safety helmets
IS 17274(Part 1) : 2019	Respiratory Protective Devices — A Methods of Test and Test Equipment Part 1 Determination of Inward Leakage
IS 17274 (Part 2) : 2019	Respiratory Protective Devices — A Methods of Test and Test Equipment Part 2 Determination of Breathing Resistance
IS 17274 (Part 3) : 2019	Respiratory Protective Devices — A Methods of Test and Test Equipment Part 3 Determination of Particle Filter Penetration
IS 17274 (Part 6) : 2019	Respiratory Protective Devices — A Methods of Test and Test Equipment Part 6 Mechanical Resistance / Strength of Components and Connections
IS 17274 (Part 7): 2019	Respiratory Protective Devices — Methods of Test and Test Equipment Part 7 Practical Performance Test Methods
IS 17274 (Part 8) : 2019	Respiratory Protective Devices Part 8 Measurement of RPD Air Flow Rates of Assisted Filtering RPD
IS 17274 (Part 9) : 2019	Respiratory Protective Devices — Methods of Test and Test Equipment Part 9 Determination of Carbon Dioxide Content of the Inhaled Gas
IS 17274 (Part 10) : 2019	Respiratory Protective Devices — Methods of Test and Test Equipment Part 10 Resistance to Ignition, Flame, Radiant Heat and Heat
IS 17274 (Part 11) : 2019	Respiratory Protective Devices — Methods of Test and Test Equipment Part 11 Determination of Field of Vision

ANNEX B

(Clauses 8.6, 8.14.2.5, and 8.14.4)

Fitting procedure for hoods which seal around the neck and which may or not incorporate a head harness

B-1 INTRODUCTION

This fitting procedure was originally developed for use in the procedure for measurement of carbon dioxide content of inhaled air. However, the fitting procedure should also be used for this type of hooded device whenever necessary in a test method in the standard e.g. breathing resistance.

B-2 PRINCIPLE

The device is fitted to a Standard dummy head which, if necessary, is mounted on a suitable torso. The arrangement is connected to a breathing machine and the appropriate test result is determined when stable conditions have been achieved.

B-3 APPARATUS

In the procedure the dummy head on the torso is fitted with a collar. The collar is sealed to the neck of the dummy and contains ports which allow air out of the hood in controlled and evenly distributed manner. By adjusting a sliding ring, more or less air is allowed out of the hood thereby controlling the pressure inside the hood (*see* Fig. 12 (a)). The test result is determined with the hood in various positions on the head (*see* Fig. 12 (b)). An elastic line is used to control the position of the hood on the head (*see* Fig. 12 (b)). If the hood is provided with a head harness then the normal fitted position shall be used.

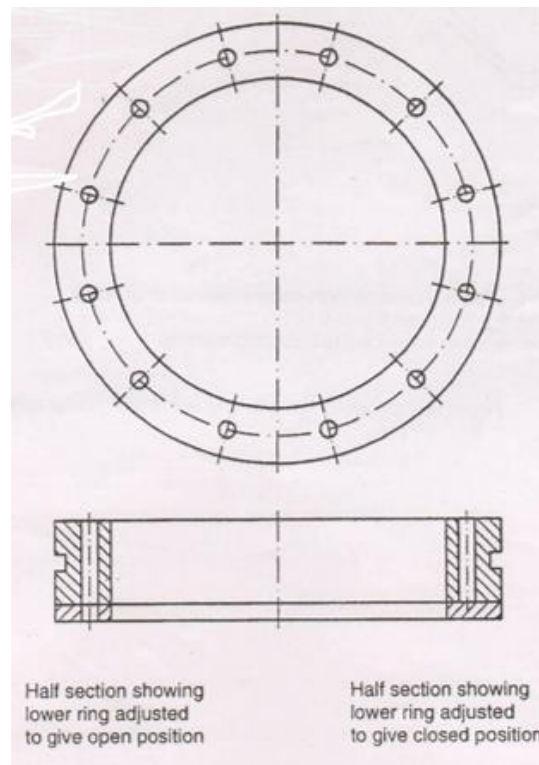
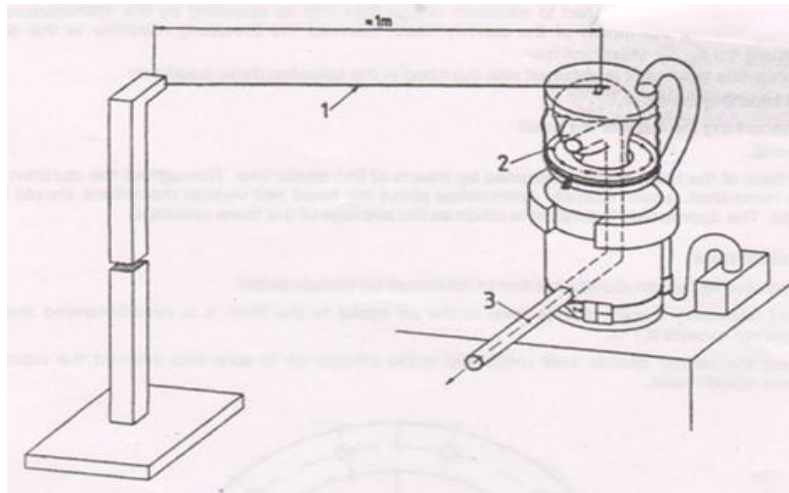

FIG. 12 (a): ADJUSTABLE FLOW COLLAR



- 1 Elastic line (allows unrestricted vertical movements of hood)
- 2 Adjustable collar (see fig. 12 (a))
- 3 Concentric tubes connected to breathing machine

FIG. 12 (b) DETAILS OF FITTING ARRANGEMENT USING COLLAR AND ELASTIC LINE

B-4 ASSESSMENT OF AVERAGE INTERNAL PRESSURE IN HOOD

At least three test subjects shall don and seal the device according to the manufacturer's information supplied by the manufacturer. The test subject holds his breath and the pressure within the hood is noted with the device operating at the initial flow rate.

The average value over the minimum of three wearings is noted.

B-5 METHOD

Fit the hood over the dummy head and tighten the drawstring (if fitted) of the neck seal tightly around the collar or, if an elasticated neck band is fitted, locate this around the collar.

Attach the elastic line from the stand to the top of the hood (*see Fig. 12 (b)*). The purpose of the elastic line is to control horizontal movement of the hood whilst having minimal effect on the vertical movement. A light elastic approximately 1 m in length has been found to be suitable.

Adjust the height of the stand so that the top of the hood is not fouled by the elastic line at the limit of its vertical movement.

Set the air flow to the hood to the initial flow rate and close the outlet ports on the collar and the outlet from the mouth of the Standard dummy head. Gradually open the outlet from the collar until the internal pressure is equal to the average pressure noted in **B-4**. Do not then disturb the setting of the collar.

Re-adjust the airflow to the hood to minimum design flow rate as specified by the manufacturer and unseal the outlet at the mouth of the dummy head. Connect the breathing machine to the dummy head.

The appropriate test result is obtained with the hood the following three positions:

- a) just touching the nose ,
- b) just touching the back of the head,
- c) central.

The position of the hood shall be adjusted by means of the elastic line. Throughout the duration of the test the hood shall remain laterally symmetrical about the head and vertical movement should not be restricted. The appropriate test result is taken as the average of the three readings.

B-6 GENERAL NOTE

When measuring carbon dioxide content of inhalation air (dead – space)

- a) Record laboratory carbon dioxide level at the air intake to the filter. It is recommended that this should not exceed 0.1 percent.
- b) Correct the carbon dioxide level measured in the inhaled air to take into account the laboratory carbon dioxide level.