

BUREAU OF INDIAN STANDARDS

DRAFT FOR COMMENTS ONLY

(Not to be reproduced without permission of BIS or used as an Indian Standard)

भारतीय मानक मसौदा
इलेक्ट्रोप्लेटिंग के लिए स्ट्रॉंटियम सल्फेट — विशिष्टि
(IS 10892 का पहला पुनरीक्षण)

Draft Indian Standard
Strontium Sulphate for Electroplating — Specification
(First Revision of IS 10982)

ICS 25.220.40

Electroplating Chemicals and Photographic Materials
Sectional Committee, CHD 5

Last Date for Comments: 22-09-2024

Electroplating Chemicals and Photographic Materials Sectional Committee, CHD 5

FOREWORD

(Formal clause will be added later)

Strontium sulphate has been regarded as one of the alkaline earths. It occurs in celestite chiefly in sedimentary rocks, where it is associated with other minerals including sulphur, calcite, gypsum, strontianite, etc.

Strontium sulphate as an electroplating chemical is specially used in self-regulating high speed chromium plating. It is also used as filler material for plastic and rubber, in pyrotechnics, ceramics/glass, and paper manufacture.

This standard was originally published in 1984. This revision has been brought out in order to incorporate alternative instrumental test methods AAS, ICP-MS and ICP-OES for the determination of iron and calcium. The relevant clauses have been added and the references have been updated.

For the purpose of deciding whether a particular requirement of this standard is complied with, the final value, observed or calculated, expressing the result of a test or analysis, shall be rounded off in accordance with IS 2: 2022 'Rules for rounding off numerical values (*second revision*)'. The number of significant places retained in the rounded off value should be the same as that of the specified value in this standard

Draft Indian Standard
**STRONTIUM SULPHATE FOR ELECTROPLATING —
SPECIFICATION**
(First Revision)

1 SCOPE

This standard prescribes the requirements, the methods of sampling and test of for strontium sulphate for electroplating.

2 REFERENCES

The standards listed in Annex A contain provisions which through reference in this text, constitute provision of this standard. At the time of publication, the editions indicated were valid. All standards are subject to revision and parties to agreements based on this standard are encouraged to investigate the possibility of applying the most recent editions of the standards.

3 REQUIREMENTS

3.1 Description

The material shall be in the form of white powder free from dirt, foreign matter and visible impurities. It dissolves appreciably in an acid medium. The material shall correspond in composition essentially to SrSO₄.

3.2 The material shall also comply with the requirements prescribed in Table 1, when tested according to methods prescribed in Annex B. Reference to the relevant clauses of Annex B is given in col 4 of the table.

Table 1 Requirements for Strontium Sulphate for Electroplating

(Clause 3.2, B-10.2.3.2, C-5.1.1, C-5.2.1)

Sl. No	Characteristic	Requirement	Method of test (Ref to Cl No. In Annex B)
(1)	(2)	(3)	(4)
i)	Strontium sulphate (as SrSO ₄), percent by mass, <i>Min</i>	96.00	B-2
ii)	Loss on ignition at 1 000 °C, percent by mass, <i>Max</i>	1.00	B-3
iii)	Matter soluble in water, percent by mass, <i>Max</i>	1.00	B-4
iv)	Chloride (as Cl), percent by mass, <i>Max</i>	0.10	B-5
v)	Sulphate (water soluble), percent by mass, (as SO ₄), <i>Max</i>	0.20	B-6
vi)	Nitrate (as NaNO ₃), percent by mass, <i>Max</i>	0.20	B-7
vii)	Carbonate* (as Na ₂ CO ₃), percent by mass, <i>Max</i>	2.00	B-8
viii)	Calcium (as Ca)#, percent by mass, <i>Max</i>	0.10	B-9
ix)	Iron (as Fe), percent by mass, <i>Max</i>	0.05	B-10

*Applicable when strontium sulphate is manufactured by precipitation of strontium nitrate with sodium sulphate.

#Applicable when strontium sulphate is manufactured by reacting strontium carbonate and sulphuric acid.

4 PACKING AND MARKING

4.1 Packing

The material shall be packed in air-tight containers, preferably with a replaceable closure. The plater usually needs to withdraw small quantities at a time from the container without the danger of powder being scattered about. The container shall, therefore, have an opening of such a size, that powder may be easily withdrawn and then the opening may be resealed without difficulty.

4.2 Marking

The container shall be securely closed and legibly and indelibly marked with the following information:

- a) Name of the material and its net mass;
- b) Name of manufacturer or its recognized trade-mark, if any;
- c) Process of manufacture; and
- d) Batch number and date of manufacture.

4.2.1 *BIS Certification Marking*

The product(s) conforming to the requirements of this standard may be certified as per the conformity assessment schemes under the provisions of the *Bureau of Indian Standards Act, 2016* and the Rules and Regulations framed thereunder, and the products may be marked with the standard mark.

5 SAMPLING

The method of drawing representative samples of the material and the criteria for its conformity with the requirements of this standard shall be as prescribed in Annex C.

ANNEX A

(Clause 2)

LIST OF REFERRED STANDARD

<i>IS</i>	<i>Title</i>
IS 264 : 2005	Nitric acid — Specification (<i>third revision</i>)
IS 265 : 2001	Hydrochloric acid — Specification (<i>fifth revision</i>)
IS 1070 : 2023	Reagent grade water — Specification (<i>fourth revision</i>)
IS 3025	Methods of sampling and test (physical and chemical) for water and wastewater
Part 2 : 2019	Determination of selected elements by inductively coupled plasma optical emission spectrometry (ICP - OES) (<i>First Revision</i>)
Part 65 : 2022	Application of inductively coupled plasma mass spectrometry (ICP-MS) — Determination of selected elements including uranium isotopes (<i>first revision</i>)
IS 4161 : 2023	Nessler Cylinder — Specification (<i>first revision</i>)
IS 4905 : 2015	Random sampling and randomization procedures (<i>first revision</i>)
ISO 24153 : 2009	
IS 13320 : 1992	Determination of iron by atomic absorption spectrophotometry — Test method

ANNEX B

(Clause 3.2)

METHOD OF TEST FOR STRONTIUM SULPHATE FOR ELECTROPLATING

B-1 QUALITY OF REAGENTS

Unless specified otherwise, pure chemicals and distilled water (*see* IS 1070) shall be used in the tests.

Note — 'Pure chemicals' shall mean chemicals that do not contain impurities which affect the result of analysis.

B-2 DETERMINATION OF STRONTIUM SULPHATE

B-2.1 Reagents

B-2.1.1 *Ammonium Carbonate*

B-2.1.2 *Concentrated Hydrochloric Acid* — *see* IS 265

B-2.1.3 *Sulphuric Acid (6N)*

B-2.1.4 *Alcohol*

B-2.2 Procedure

Weigh 0.03 g to 0.05 g sample (M) into 250 ml beaker. Add 100 ml water. Add approximately 15 g ammonium carbonate. Heat to boiling and keep it in warm place and allow to stand overnight. Make acidic with hydrochloric acid, filter, if necessary. Heat to boiling and add 5 ml sulphuric acid with constant stirring for complete precipitation. Add alcohol equivalent to the volume of the solution. Let it stand for overnight. Filter through Whatman filter paper No. 42 and wash first with alcohol (60 percent) to which a little sulphuric acid has been added and finally with pure alcohol. Preserve the filtrate for further test. Ignite the precipitate to dull redness (or in an electrical muffle furnace at 500 °C to 600 °C, cool and weigh (M_1)).

B-2.3 Calculation

$$\text{Strontium sulphate (as SrSO}_4\text{), percent by mass} = \frac{M_1 \times 100}{M}$$

where

M_1 = mass in g, after ignition, and

M = mass in g, of the material taken for the test.

NOTE — To confirm the presence of strontium, make a flame test using a hydrochloric acid solution of the salt. A crimson flame indicates the presence of strontium.

B-3 DETERMINATION OF LOSS ON IGNITION

B-3.1 Procedure

Weigh accurately about 1 g of the sample and heat it for two to three hour in a muffle furnace at 1 000 °C. Determine the loss in mass after cooling the residue in a desiccator.

B-3.2 Calculation

$$\text{Ignition residue, percent by mass} = \frac{M_1 \times 100}{M}$$

where

M_1 = loss in mass in g, of the residue, and

M = mass in g, of the material taken for the test.

B-4 DETERMINATION OF MATTER SOLUBLE IN WATER

B-4.1 Procedure

Weigh accurately about 10 g of the material and boil with about 150 ml of water, filter through Whatman filter paper No. 42, wash through with water. Evaporate the combined filtrate and washing in a glass basin on evaporating bath. Heat for about one hour in air oven at $105\text{ }^{\circ}\text{C} \pm 10\text{ }^{\circ}\text{C}$, cool and weigh. Reserve residue.

B-4.2 Calculation

$$\text{Matter soluble in water, percent by mass} = \frac{M_1 \times 100}{M}$$

where

M_1 = mass in g, of the residue left after evaporation, and

M = mass in g, of the material taken for the test.

B-5 DETERMINATION OF CHLORIDE

B-5.1 Reagents

B-5.1.1 *Concentrated Nitric Acid* — see IS 264

B-5.1.2 *Silver Nitrate Solution* — approximately 0.1 N.

B-5.2 Procedure

Weigh 5 g to 10 g sample into a 250 ml beaker. Add 150 ml water and 10 ml to 15 ml of nitric acid. Heat to boiling and cool. Filter through Whatman filter paper No. 41 (12.5 cm). Heat to boiling and add 10 ml to 12 ml of silver nitrate solution. Allow to settle and test for complete precipitation. Filter through sintered crucible (G. No. 4). Dry at $100\text{ }^{\circ}\text{C}$ to $110\text{ }^{\circ}\text{C}$ to constant mass.

B-5.3 Calculation

$$\text{Chloride (as Cl), percent by mass} = \frac{M_1 \times 24.74}{M}$$

M_1 = Mass in g, of the dried precipitation, and

M = mass in g, of the material taken for the test.

B-6 DETERMINATION OF SULPHATE

B-6.1 Reagents

B-6.1.1 *Concentrated Hydrochloric Acid* — see IS 265

B-6.1.2 *Barium Chloride Solution* — 12 percent (m/v).

B-6.2 To the residue reserved in **B-4.1** add 1 ml of HCl and about 10 ml to 15 ml of water, heat to boiling, filter through Whatman filter paper No. 42 if not cleared, wash thoroughly. Boil the combined filtrate and washings, add 5 ml to 10 ml of barium chloride solution, boil for a few minutes and allow to settle overnight. Filter through Whatman filter paper No. 42, wash with water till free from chlorides. Ignite the filter paper and precipitate in a crucible to dull redness (or in an electric muffle furnace at $500\text{ }^{\circ}\text{C}$ to $600\text{ }^{\circ}\text{C}$) to constant mass, cool and weigh as sulphate.

B-6.3 Calculation

$$\text{Sulphate (as } \text{SO}_4 \text{), percent by mass} = \frac{41.15 \times M_1}{M}$$

where

M_1 = mass in g, of the precipitate, and

M = mass in g, of the material taken for the test.

B-7 DETERMINATION OF NITRATES

B-7.1 General

Nitrates are reduced to ammonia which is absorbed in standard acid and excess of acid is titrated with standard solution.

B-7.2 Apparatus

The apparatus, as assemble, is shown in Fig. 1. It consists of a round bottom flask *A* of 1 000 ml capacity fitted with a rubber stopper through which passes one end of the connecting bulb tube *B*. The other end of the bulb tube *B* is connected to the condenser by means of a rubber tubing to a clip tube *D* which dips into breaker *E* of 250 ml capacity.

B-7.3 Reagents

B-7.3.1 Sodium Hydroxide Solution — 1 percent (*m/v*).

B-7.3.2 Standard Hydrochloric Acid — 0.1 N approximately.

B-7.3.3 Devarda's Alloy

B-7.3.4 Standard Sodium Hydroxide Solution — 0.1 N approximately.

B-7.2.5 Methyl Red Indicator Solution — Dissolve 0.15 g of methyl red in 500 ml of water.

B-7.4 Procedure

Weigh accurately about 25 g of the material and dissolve in 250 ml of sodium hydroxide at $80\text{ }^{\circ}\text{C} \pm 2\text{ }^{\circ}\text{C}$. After maintaining a temperature of $80\text{ }^{\circ}\text{C} \pm 2\text{ }^{\circ}\text{C}$ for 30 min, filter the solution through 11 cm filter little paper (Whatman filter paper No. 40 or equivalent) containing a little filter pulp. Wash the residue with 100 ml of sodium hydroxide solution and then wash free from alkali with water. Transfer the filtrate and washings to a 500 ml graduated flask, make up to the mark with sodium hydroxide solution. Take 200 ml of this solution in the flask *A*, add 20 g of sodium hydroxide and 2.5 g of Devarda's Alloy and assemble the apparatus as shown in Fig. 1. Take 25 ml of standard hydrochloric acid in beaker *E*, and gently warm the flask *A* when the evolution of gas has ceased, boil the contents of the flask vigorously for 15 min. Titrate the solution in the beaker with standard sodium hydroxide solution using methyl red as indicator. Carry out a blank determination as above.

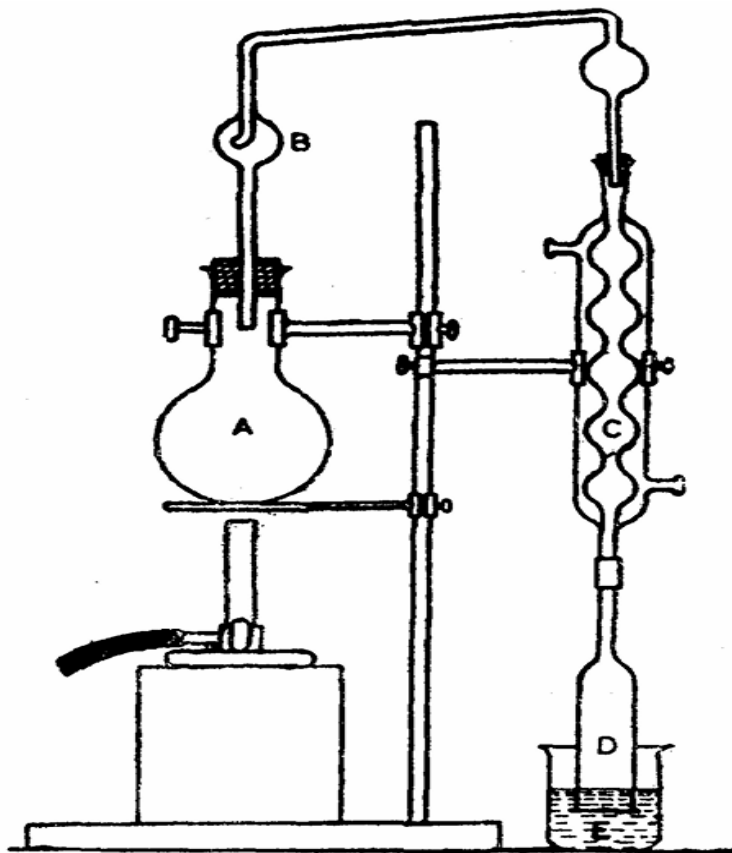

FIG. 1 APPARATUS FOR THE DETERMINATION OF NITRATES

B-7.5 Calculation

$$\text{Nitrate (as NaNO}_3 \text{), percent by mass} = \frac{8.501(V - V_1)N}{M}$$

where

V = volume in ml, of standard hydroxide solution used, in titration with blank,

V_1 = volume in ml, of standard sodium hydroxide solution used in titration with material,

N = normality of standard sodium hydroxide solution, and

M = mass in g, of the material equivalent to 200 ml of solution taken for the test.

B-8 DETERMINATION OF CARBONATES

B -8.1 Principle

Carbon dioxide is generated by adding dilute hydrochloric acid in vacuum and is absorbed in an excess of alkali which is back titrated with a standard hydrochloric acid.

B-8.2 Apparatus

B-8.2.1 Kjeldahl Flask — 300 ml capacity.

B-8.2.2 Drechsel Bottle — provided with two taps.

B-8.2.3 Vacuum Pump — to give pressure less than 10 cm of Hg.

B-8.2.4 Top Funnel

B-8.3 Reagents

B-8.3.1 Methyl Orange Indicator — dissolve 0.8 g of methyl orange in 100 ml of water.

B-8.3.2 Sodium Hydroxide Solution — 1 N.

B-8.3.3 Barium Chloride Solution — 10 percent.

B-8.3.4 Phenolphthalein Indicator — dissolve 0.1 g of phenolphthalein in 100 ml of 60 percent rectified spirit.

B-8.3.5 Dilute Hydrochloric Acid — 5 N, 1 N and 0.1 N.

B-8.4 Procedure

Take 5 g of the accurately weighed material in a 300 ml Kjeldahl flask *A* and add about 100 ml of water and two drops of methyl orange indicator. Assemble the apparatus as shown in Fig. 2. Provide a flask *A* with a rubber bung through which passes a short bend of wide capillary tubing and a tap funnel *B* reaching nearly to the bottom of the flask. Place 20 ml of sodium hydroxide solution, 20 ml of barium chloride solution and 1 ml phenolphthalein in the Drechsel bottle *C* provided with taps *E* and *F*. Connect this bottle to the kjeldahl flask and evacuate the whole assembly to less than 100 mm mercury pressure using a vacuum pump. Introduce 40 ml of 5 N hydrochloric acid through the tap funnel *B* into the flask (the precipitated aluminum hydroxide should redissolve in the acid and an excess of the acid should be present as indicated by methyl orange), avoiding the admission of air. Keep about 1 ml of acid in the funnel to prevent air leaking during subsequent operation. Heat the flask over a small flame until the outer capillary tube becomes hot, shaking the Drechsel bottle occasionally to absorb the carbon dioxide. The solution in Drechsel bottle should remain pink. Fill flask *A* with boiling water through the tap to flush out any traces of CO₂ held back in the flask. Shake the Drechsel bottle and disconnect it after removing the vacuum by opening the outlet cap *F*. Titrate the excess sodium hydroxide with 1 N hydrochloric acid (phenolphthalein already present) so as not to overlap the end point. Boil off carbon dioxide. It is better to complete this titration near the end point with 0.1 N hydrochloric acid till the solution is just colourless. Add two drops of methyl orange indicator and an excess of 1 N hydrochloric acid (*V*₁). Shake well and titrate with sodium hydroxide solution (*V*₂). Carry out the blank in the same way.

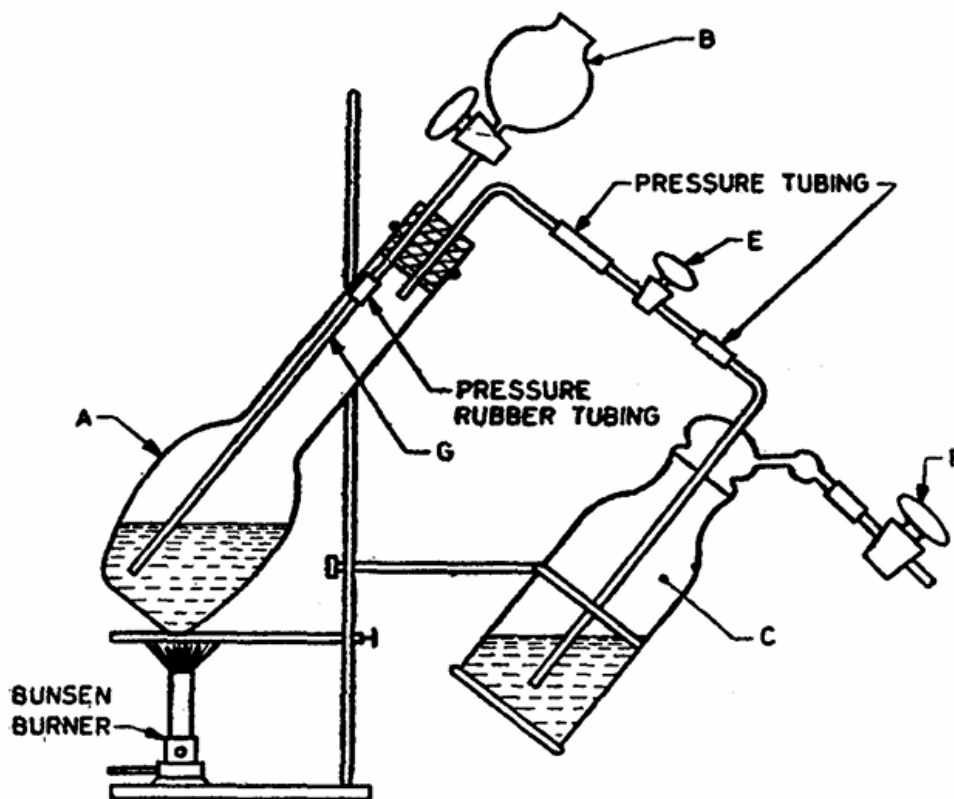

FIG. 2 APPARTUS FOR THE DETERMINATION OF CARBONATES

B-8.5 Calculation

$$\text{Carbonates (as Na}_2\text{CO}_3\text{), percent by mass} = \frac{[V_1 - (V_3 - V_2)] \times 0.053 \times 100}{M}$$

where

V_1 = excess of standard hydrochloric acid (1 N) added to the solution,

V_2 = volume of standard sodium hydroxide solution consumed in the titration,

V_3 = volume of standard hydrochloric acid (1 N) used for blank titration, and

M = mass in g, of the material taken for the test.

B-9 DETERMINATION OF CALCIUM

B-9.1 General

Three methods are described for the determination of calcium. Either of these may be used for general routine purposes, but in case of a dispute method B shall be the referee method.

B-9.2 Method A

B-9.2.1 Reagents

B-9.2.1.1 *Liquor ammonia*

B-9.2.1.2 *Ammonium Oxalate Solution* — 10 percent (m/v).

B-9.2.2 Procedure

Take the filtrate obtained in **B-2.2** and boil it for half an hour. Cool and make it ammoniacal. Heat to boiling and added 10 ml ammonium oxalate solution. Allow to stand for an hour. Filter through Whatman filter paper No. 42 (11 cm). Ignite the precipitate, cool and weigh till constant mass is obtained.

B-9.2.3 Calculation

$$\text{Calcium (as Ca), percent by mass} = \frac{M_1}{M} \times 71.48$$

where

M_1 = mass in g, of the ignited material, and

M = mass in g, of the material taken for the test (see **B-2.2**)

B-9.3 Method B

Determine calcium content by ICP-MS in accordance with the method prescribed in IS 3025 (Part 65).

B-9.4 Method C

Determine calcium content by ICP-OES in accordance with the method prescribed in IS 3025 (Part 2).

B-10 DETERMINATION OF IRON

B-10.1 General

Four methods are described for the determination of iron. Either of these may be used for general routine purposes, but in case of a dispute method C shall be the referee method.

B-10.2 Method A

B-10.2.1 Apparatus

B-10.2.1.1 Nessler's cylinders — 50 ml capacity (see IS 4161)

B-10.2.2 Reagents

B-10.2.2.1 Dilute hydrochloric acid — 4 N approximately.

B-10.2.2.2 Potassium permanganate solution — 0.01 N approximately.

B-10.2.2.3 Ammonium thiocyanate solution — 50 percent (m/v)

B-10.2.2.4 Extraction solvent — prepared by mixing equal volume of amyl alcohol and amylacetate.

B-10.2.2.5 Standard iron solution

Dissolve 0.720 g of ferrous ammonium sulphate [$\text{FeSO}_4(\text{NH}_4)_2\text{SO}_4 \cdot 6\text{H}_2\text{O}$] in water containing 10 ml of dilute sulphuric acid. [10 percent (v/v)] and dilute with water to 1 000 ml. Before use, again dilute 100 ml of this solution in equivalent to 0.01 mg of iron (as Fe).

B-10.2.3 Procedure

B-10.2.3.1 Weigh accurately about 1 g of material and dissolve 20 ml of water and just sufficient HCl at 10 ml of HCl in excess. Dilute to 100 ml in a volumetric flask. Take 10 ml of aliquot in a Nessler's cylinder, add one drop of permanganate solution and mix. Add 5 ml of ammonium thiocyanate solution and 10 ml of extraction solvent (a mixture of amly alcohol and ether in the ratio 5 : 2) and mix. Shake vigorously and allow the layers to separate. Carry

out a controlled test in a similar manner in another Nessler's Cylinder containing 5 ml of a standard Fe solution (1 ml = 0.01 mg/ml of Fe).

B-10.2.3.2 The material shall be taken to have not exceeded the limit prescribed in Table 1 if the intensity of colour produced by material is not greater than that produced in the control test.

B-10.3 Method B

Determine iron content by atomic absorption spectrophotometer (AAS) in accordance with the method prescribed in IS 13320.

B-10.4 Method C

Determine iron content by ICP-MS in accordance with the method prescribed in IS 3025 (Part 65).

B-10.5 Method D

Determine iron content by ICP-OES in accordance with the method prescribed in IS 3025 (Part 2).

ANNEX C

(Clause 5)

SAMPLING OF STRONTIUM SULPHATE FOR ELECTROPLATING

C-1 GENERAL REQUIRMENTS OF SAMPLING

C-1.1 In drawing, preparing, storing and handling test samples, the following precautions and directions shall be observed.

C-1.2 Precautions shall be taken to protect the sample, the material being sampled, the sampling instrument and the containers for samples from adventitious contamination.

C-1.3 To draw a representative sample, the contents of each container selected for sampling shall mixed as thoroughly as possible by suitable means.

C-1.4 The samples shall be placed in suitable, clean, dry and air-tight glass or other suitable containers on which the material has no action.

C-1.5 Each sample container shall be sealed air-tight after filling and marked with full details of sampling the date of sampling and the year of manufacture of the material.

C-2 SCALE OF SAMPLING

C-2.1 Lot

All the containers in a single consignment of the material drawn from a single batch of manufacture shall constitute a lot. If a consignment is declared or known to consist of different batches of manufacture, the containers belonging to the same batch shall be grouped together and each such group shall constitute a separate lot.

C-2.1.1 Samples shall be tested from each lot for ascertaining conformity of the material to the requirements of the specification.

C-2.2 The number (n) of containers to be chosen from a lot shall depend on the size of the lot (N) and shall be in accordance with Table 2.

Table 2 Number of Containers to be Selected

(Clause C-2.2)

SI No.	Lot Size	Number of Containers to be Selected
(1)	(N)	(n)
(1)	(2)	(3)
i)	Up to 50	3
ii)	51 to 100	4
iii)	101 to 150	5
iv)	151 to 300	7
v)	301 and above	10

C-2.3 All the containers shall be selected at random and in order to ensure the randomness of selection, procedures given in IS 4905 may be followed.

C-3 TEST SAMPLES AND REFEREE SAMPLE

C-3.1 Preparation of Test Sample

C-3.1.1 Draw with an appropriate sampling instrument a small portion of the material from different parts of each container selected. The total quantity of the material drawn from each container shall be sufficient to conduct the tests for all the characteristics given under 2 and shall not exceed 500 g.

C-3.1.2 Thoroughly mix all portions of the material drawn from the same container. Out of these portions a small but equal quantity shall be taken from each selected container and shall be well mixed up together so as to form a composite sample weighing not less than 200 g. This composite sample shall be divided into three equal parts one for the supplier and the third to be used as referee

C-3.1.3 The remaining portions of the material from each container (after a small quantity needed for the formation of competitive sample has been taken) shall be divided into three equal parts, each part weighing not less than 50 g. These parts shall be immediately transferred to thoroughly dried bottles which are then sealed air-tight with stoppers material and labelled with all the particulars of sampling given under **C-1.5**. The material in each such sealed bottle shall constitute an individual test sample. These individual samples shall be separated into three identical sets of samples in such a way that each set has an individual test sample representing each container selected. One of these three sets shall be sent to the purchaser, another to the supplier and the third shall be used as referee sample.

C-3.2 Referee Sample

The referee sample shall consist of the composite sample (*see C-3.1.2*) and a set of individual samples (*see C-3.1.3*) marked for this purpose. It shall also bear the seals of the purchaser and the supplier. These shall be kept at a place agreed to between the purchaser and the supplier and shall be used in case of dispute between the two.

C-4 NUMBER OF TESTS

C-4.1 Test for the determination of strontium sulphate shall be conducted on each of the individual samples for all the grades.

C-4.2 Tests for the remaining characteristics shall be conducted on the composite sample.

C-5 CRITERIA FOR CONFORMITY

C-5.1 For Individual sample

C-5.1.1 *For Strontium Sulphate*

The test results for strontium sulphate shall be recorded, and the mean and range for these test result shall be calculated as follows

Mean (\bar{X}) = Sum of the test results divided by the number of test results,

Range (R) = The difference between the maximum and minimum values of test results.

The value of expression ($\bar{X} - 0.6 R$) shall be calculated. If the value of this expression is greater than or equal to limits specified in Table 1, the lot shall be declared to have satisfied the requirements for these characteristics.

C- 5.1.1.1 In case of sample of size 10, the first five test results may be taken in one group and the next five in another group. R shall be calculated as R . If $\bar{X} - 0.6 R$ is greater than or equal to the limits specified in Table 1, the lot shall be declared to have satisfied the requirements for these characteristics.

C-5.2 For Composite Sample

The test results on the composite sample shall meet the corresponding requirement specified in Table 1.

C-5.3 A lot shall be declared as conforming to the specification if it satisfies the requirements for each of the characteristics listed in Table 1.