



भारतीय मानक ब्यूरो

(उपभोक्ता मामले, खाद्य एवं सार्वजनिक वितरण मंत्रालय, भारत सरकार)

BUREAU OF INDIAN STANDARDS

(Ministry of Consumer Affairs, Food & Public Distribution, Govt. of India)

मानक भवन, 9, बहादुर शाह ज़फ़र मार्ग, नई दिल्ली - 110002

Manak Bhawan, 9, Bahadur Shah Zafar Marg, New Delhi - 110002

Phones: 23230131 / 2323375 / 23239402

Website: www.bis.gov.in, www.manakonline.in

व्यापक परिचालन मसौदा

हमारा संदर्भ : सीईडी 50/टी-94

10 जनवरी 2025

तकनीकी समिति : प्लास्टिक पाइपिंग पद्धति विषय समिति, सीईडी 50

प्राप्तकर्ता :

1. सिविल अभियांत्रिकी विभाग परिषद, सीईडीसी के सभी सदस्य
2. अग्नि शमन विषय समिति, सीईडी 50 और इसकी उपसमितियों के सभी सदस्य
3. रुचि रखने वाले अन्य निकाय।

महोदय/महोदया,

निम्नलिखित मानक का मसौदा संलग्न है:

प्रलेख संख्या	शीर्षक
सीईडी 50 (27107)WC	इमारत संरचना के भीतर मिट्टी और अपशिष्ट निर्वहन (कम और उच्च तापमान) के लिए पॉलीप्रोपाइलीन (पीपी) प्लास्टिक पाइपिंग सिस्टम भाग 1 सिंगल लेयर पॉलीप्रोपाइलीन (पीपी) पाइपिंग सिस्टम (ICS No. 91.140.80)

कृपया इस मसौदे का अवलोकन करें और अपनी सम्मतियाँ यह बताते हुए भेजे कि यह मसौदा प्रकाशित हो तो इन पर अमल करने में आपको व्यवसाय अथवा कारोबार में क्या कठिनाइयाँ आ सकती हैं।

सम्मतियाँ भेजने की अंतिम तिथि: 09 फ़रवरी 2025

सम्मति यदि कोई हो तो कृपया अधोहस्ताक्षरी को ई-मेल द्वा ced50@bis.gov.in पर या उपरलिखित पते पर, संलग्न फॉर्मेट में भेजें। सम्मतियाँ बीआईएस ई-गवर्नेंस पोर्टल, www.manakonline.in के माध्यम से ऑनलाइन भी भेजी जा सकती हैं।

यदि कोई सम्मति प्राप्त नहीं होती है अथवा सम्मति में केवल भाषा संबंधी त्रुटि हुई तो उपरोक्त प्रालेख को यथावत अंतिम रूप दे दिया जाएगा। यदि सम्मति तकनीकी प्रकृति की हुई तो विषय समिति के अध्यक्ष के परामर्श से अथवा उनकी इच्छा पर आगे की कार्यवाही के लिए विषय समिति को भेजे जाने के बाद प्रालेख को अंतिम रूप दे दिया जाएगा।

यह प्रालेख भारतीय मानक ब्यूरो की वेबसाइट www.bis.gov.in पर भी उपलब्ध हैं।

धन्यवाद।

भवदीय

ह/-

द्वैपायन भद्र

वैज्ञानिक ई एवं प्रमुख
सिविल अभियांत्रिकी विभाग
ई-मेल: ced50@bis.gov.in

संलग्न: उपरलिखित



भारतीय मानक ब्यूरो
(उपभोक्ता मामले, खाद्य एवं सार्वजनिक वितरण मंत्रालय, भारत सरकार)
BUREAU OF INDIAN STANDARDS
(Ministry of Consumer Affairs, Food & Public Distribution, Govt. of India)

मानक भवन, 9, बहादुर शाह ज़फर मार्ग, नई दिल्ली – 110002
Manak Bhawan, 9, Bahadur Shah Zafar Marg, New Delhi – 110002
Phones: 23230131 / 2323375 / 23239402
Website: www.bis.gov.in, www.manakonline.in

WIDE CIRCULATION DRAFT

Our Reference: CED 50/T-94

10 January 2025

TECHNICAL COMMITTEE: PLASTIC PIPING SYSTEM SECTIONAL COMMITTEE, CED 50

ADDRESSED TO:

1. All Members of Civil Engineering Division Council, CEDC
2. All Members of Plastic Piping System Sectional Committee, CED 50 and its Subcommittees
3. All others interested.

Dear Sir/Madam,

Please find enclosed the following draft:

Doc No.	Title
CED 50 (27107)WC	POLYPROPYLENE (PP) PLASTIC PIPING SYSTEMS FOR SOIL AND WASTE DISCHARGE (LOW AND HIGH TEMPERATURE) WITHIN THE BUILDING STRUCTURE Part 1 Single Layer Polypropylene (PP) Piping System (ICS No. 91.140.80)

Kindly examine the attached draft and forward your views stating any difficulties which you are likely to experience in your business or profession, if this is finally adopted as National Standard.

Last Date for comments: 09 February 2025

Comments if any, may please be made in the enclosed format and emailed at ced50@bis.gov.in or sent at the above address. Additionally, comments may be sent online through the BIS e-governance portal, www.manakonline.in.

In case no comments are received or comments received are of editorial nature, kindly permit us to presume your approval for the above document as finalized. However, in case comments, technical in nature are received, then it may be finalized either in consultation with the Chairman, Sectional Committee or referred to the Sectional Committee for further necessary action if so desired by the Chairman, Sectional Committee.

The document is also hosted on BIS website www.bis.gov.in.

Thanking you,

Yours faithfully,

Sd/-

Dwaipayan Bhadra

Scientist 'E' & Head

Civil Engineering Department

Email: ced50@bis.gov.in

Encl: As above

FORMAT FOR SENDING COMMENTS ON THE DOCUMENT

[Please use A4 size sheet of paper only and type within fields indicated. Comments on each clause/sub-clause/ table/figure, etc, be stated on a fresh row. Information/comments should include reasons for comments, technical references and suggestions for modified wordings of the clause. **Comments through e-mail to ced50@bis.gov.in shall be appreciated.**]

Doc. No.: CED 50 (27107)WC

BIS Letter Ref: CED 50/T-94

Title: POLYPROPYLENE (PP) PLASTIC PIPING SYSTEM FOR SOIL AND WASTE DISCHARGE (LOW AND HIGH TEMPERATURE) WITHIN THE BUILDING STRUCTURE

Part 1 Single Layer Polypropylene (PP) Piping System

(ICS No. 91.140.80)

Last date of comments: 09 February 2025

Name of the Commentator/ Organization: _____

SI No.	Clause/ Para/ Table/ Figure No. commented	Type of Comment (General/ Technical/ Editorial)	Comments/ Modified Wordings	Justification of Proposed Change

NOTE- Kindly insert more rows as necessary for each clause/table, etc

BUREAU OF INDIAN STANDARDS**DRAFT FOR COMMENTS ONLY**

(Not to be reproduced without the permission of BIS or used as a Standard)

Draft Indian Standard**POLYPROPYLENE (PP) PLASTIC PIPING SYSTEMS FOR SOIL AND
WASTE DISCHARGE (LOW AND HIGH TEMPERATURE)
WITHIN THE BUILDING STRUCTURE****Part 1 Single Layer Polypropylene (PP) Piping System**

Plastic Piping System
Sectional Committee, CED 50

Last Date of Comments:
09 February 2025

FOREWORD

(Formal clauses to be added later.)

The PP piping application for soil and waste discharge is comparatively new in Indian context, however it is quite established in other parts of the world. The standard covers both single layer and multilayer PP pipes as well as such fittings. The scope of the standard has been restricted for application of such pipes within the building structure. The types and dimensions have been kept as per the manufacturing practices prevailing in the country.

During preparation of standard, initial draft was made by combining all test requirements and construction of pipe together however committee realize that it is better to separate pipes based on application, construction and testing.

Hence the standard has been formulated to cover polypropylene (PP) plastic piping system as Part 1 and Part 2 for soil and waste discharge with and without noise control for both low and high temperature applications within the building structure as per scope below.

Single layer Polypropylene (PP) pipes covered under Part 1 are intended for use in soil and waste discharge system, ventilation pipe work and rainwater discharge, and rainwater harvesting application.

Structured wall / multilayer layer polypropylene (PP) pipes covered under Part 2 are intended for use in:

- a) Soil and waste discharge system, ventilation pipe work and rainwater discharge, and rainwater harvesting application, and
- b) Soil and wastage discharge system with noise control (Acoustic) application.

Formulation of new Indian Standard is based on ISO 7671:2003 'Plastic piping systems for soil and waste discharge (low and high temperature) inside buildings – Polypropylene (PP) and EN 1451- Polypropylene (PP) plastics piping systems for soil and waste discharge - Dimensions within the building structure, with and without including acoustic test requirements.

Assistance has been derived from the following International Standards in the formulation of this standard:

ISO 7671:2003	Plastic piping systems for soil and waste discharge (low and high temperature) inside buildings – Polypropylene (PP)
EN 1451	Polypropylene (PP) plastics piping systems for soil and waste discharge – Dimensions

For the purpose of deciding whether a particular requirement of this standard is complied with the final value, observed or calculated, expressing the result of test or analysis, shall be rounded off in accordance with IS 2:1960 'Rules for rounding off numerical value (revised)'. The number of significant places retained in the rounded off value should be the as that of the specified value in this standard.

BUREAU OF INDIAN STANDARDS**DRAFT FOR COMMENTS ONLY**

(Not to be reproduced without the permission of BIS or used as a Standard)

Draft Indian Standard**POLYPROPYLENE (PP) PLASTIC PIPING SYSTEMS FOR SOIL AND
WASTE DISCHARGE (LOW AND HIGH TEMPERATURE)
WITHIN THE BUILDING STRUCTURE****Part 1 Single Layer Polypropylene (PP) Piping System**

Plastic Piping System
Sectional Committee, CED 50

Last Date of Comments:
09 February 2025

1 SCOPE

1.1 Single layer Polypropylene (PP) pipes covered under Part 1 are intended for use in soil and waste discharge system, ventilation pipe work and rainwater discharge, and rainwater harvesting application.

1.2 This standard covers the requirement for plain and socket end polypropylene (PP) pipes with nominal outside diameter 32 mm to 315 mm.

1.3 Pipes and fittings of Pipe series S20 shall be used for ventilation pipe work, rainwater and rainwater harvesting application. Pipe series S20, DN 75 mm and above shall be used for soil and waste discharge system and sewerage system. All S16 and S14 series pipes and fittings shall be used for soil and waste discharge system and sewerage system.

1.4 This standard also covers fittings which can be injection molded with polypropylene (PP). Fabricated Fittings manufactured from PP Pipes are also covered in this standard.

1.5 The standard also covers the requirement for joining system of PP Pipes and Fittings; and also for their connections with components of other plastic materials intended to be used for the above purpose.

1.6 The fittings with integral elastomeric sealing ring have been considered. Components to be used with pipe and fittings for which the specification has not been covered in this standard, shall be as agreed between the manufacturer and the purchaser. However, they shall conform to the requirements of joint dimension and functional requirement given in this standard.

2 REFERENCES

The following standards contain provisions which, through reference in this text, constitute provisions of this standard. At the time of publication, the editions indicated were valid. All standards are subject to revision and parties to agreements based on this standard are encouraged to investigate the possibility of applying the most recent editions of the standards indicated below:

<i>IS No</i>	<i>Title</i>
IS 4984:2016	Polyethylene pipes for water supply - Specification (<i>fifth revision</i>)
IS 5382:2018	Rubber seals - Joint rings for water supply, drainage and sewerage pipelines - Specification for materials (<i>second revision</i>)
IS 10951:2020	Specification for polypropylene (PP) materials for moulding and extrusion (<i>second revision</i>)
IS 12235	Thermoplastic pipes and fittings – Methods of test
Part 6:2004	Stress relief test
Part 9:2004	Resistance to external blows (impact resistance) at 0°C (round-the-clock method)
IS 16098	Structured-wall plastics piping systems for non-pressure drainage and sewerage
Part 1:2003	Part 1 Pipes and fittings with smooth external surface, Type A
Part 2:2013	Part 2 Pipes and fittings with non-smooth external surface, Type B

3 TERMINOLOGY

For the purpose of this standard, the following definitions shall apply:

3.1 Copolymer — A polymer derived from more than one species of monomer.

3.2 Homopolymer — A polymer derived from one species of monomer.

3.3 Mean Inside Diameter of a Socket (d_{sm}) — The arithmetical mean of a number of measurements of the inside diameter of a socket in the same cross-section.

3.4 Mean Outside Diameter (d_{em}) — The measured outer circumference of a pipe or spigot end of a fitting in any cross-section square to the pipe axis, divided by π (= 3.142), rounded to the next greater 0.1 mm.

3.5 Mean Wall Thickness (e_m) — The arithmetical mean of a number of measurements of the wall thickness, regularly spaced around the circumference and in the same cross-section of a component, including the measured minimum and the measured maximum values of the wall thickness in that cross-section.

3.6 Nominal Outside Diameter (d_n) — The specified outside diameter in millimeters, assigned to a nominal size *DN/OD*.

3.7 Nominal Ring Stiffness (SN) — A numerical designation of the ring stiffness of a pipe or fitting, which is a convenient round number relative to the determined stiffness in kilo-newton per square meter (kN/m²), indicating the minimum ring stiffness of a pipe or fitting.

3.8 Nominal Size (DN) — A numerical designation of the size of a component which is approximately equal to the manufacturing dimension, in millimeters.

3.9 Nominal Size (DN/OD) — Nominal size related to the outside diameter.

3.10 Outside Diameter (d_e) — The measured outside diameter through its cross-section at any point of a pipe or spigot end of a fitting, rounded to the next greater 0.1 mm.

3.11 Own Re-Processable Material — Material prepared from rejected unused pipes or fittings, including trimmings from the production of pipes or fittings, that will be reprocessed in a manufacturer's plant after having been previously processed by the same manufacturer by a process such as moulding or extrusion, and for which the complete formulation is known.

3.12 Pipe Series (S) — A dimensionless number for pipe designation.

3.13 Tests

3.13.1 Type Tests — Tests carried out whenever a change is made in the composition or in the size/series in order to establish the suitability and the performance capability of the pipes and fittings.

3.13.2 Acceptance Tests — Tests are carried out on samples taken from a lot for the purpose of acceptance of the lot.

3.14 Wall Thickness (e) — The measured wall thickness at any point around the circumference of a component.

3.15 Virgin Material — Material in a form such as granules or powder that has not been subjected to use or processing other than that required for its manufacture and to which no re-processable or recyclable material has been added.

4 SYMBOLS

A	= length of engagement, or maximum pull-out whilst maintaining tightness
B	= length of lead-in
C	= depth of sealing zone
D_i	= socket inside diameter
DN	= Nominal size
DN/OD	= Nominal size, outside diameter related
$D_{im,min}$	= minimum mean inside diameter of a socket
d_e	= outside diameter

d_{em}	=	Mean outside diameter
d_n	=	Nominal outside diameter
d_s	=	Inside diameter of a socket
d_{sm}	=	Mean inside diameter of a socket
e	=	Wall thickness
e_m	=	Mean wall thickness
S	=	Pipe series
SN	=	Nominal ring stiffness
e_2	=	wall thickness of a socket
e_3	=	wall thickness in the groove area
l	=	effective length of a pipe
$L_{1,min}$	=	minimum length of a spigot
R	=	radius of swept fittings
Z	=	Z-lengths of a fitting
α	=	nominal angle of a fitting

The abbreviations given below apply to this standard:

MFR	–	melt mass-flow rate
OIT	–	oxidation induction time
PP	–	polypropylene
PP-H	–	polypropylene homo polymer
TIR	–	true impact rate

5 SIZES

Nominal outside diameter, DN of pipes/fittings as covered in the standard are 32, 40, 50, 63, 75, 90, 110, 125, 160, 200, 250 and 315 mm.

6 DESIGNATION

Pipes/Fittings shall be designated by their nominal outside diameter, pipe series, stiffness class and application area code and class of the material (see 8.1.4).

7 COLOUR OF PIPES

Colour of pipes/fittings shall be white, black or grey shade. Other colours as agreed between the manufacturer and the purchaser may also be supplied. Inside layer of the pipes/fittings shall be white or grey shade. The pipes/fittings, single (individual layers) shall be uniformly coloured throughout their entire thickness.

8 MATERIALS

8.1 Pipes and Fittings

8.1.1 The materials from which pipes and injection moulded fittings are produced shall essentially consist of polypropylene to which may be added only those additives that are needed to facilitate the durable pipes of good surface finish, mechanical strength, and opacity under condition of use. None of these additives shall be used separately or together in quantities sufficient to constitute a toxic hazard, impairing the fabrication,

welding, chemical and physical properties of the pipes. The material should also consist of sufficient quantity of stabilizer to help the pipe/fitting withstand thermal ageing and exposure to ultra-violet light conditions inside building. And Material Characteristics for PP Material in Granules Form should be meet the table 1

8.1.2 For both pipes/fittings, the percentage of additives (other than mineral additive in case of pipes/fittings) by mass, shall be declared by the pipe/fitting manufacturer which shall be less than 0.3 percent.

Table 1 Material Characteristics for PP Material in Granules Form
(Clause 8.1.1)

Sl No.	Characteristics	Requirements	Test Parameters		Test Method
(1)	(2)	(3)	(4)		(5)
i)	Melt Flow Rate (MFR)	≤ 3/10 min	Temperature	230 °C	IS 13360 (Part 4/ Sec 1)
			Loading Mass	2.16 kg	
ii)	Thermal stability (OIT) ¹⁾	≥ 8 minutes	Temperature	200 °C	As per Annex B of IS 4984
¹⁾ This requirement is only valid for pipes and fittings intended to be jointed in field by fusing or welding.					

8.1.3 Fabricated fittings or parts of fabricated fitting (for assembly with injection moulded fitting) shall be made from pipes and/or moulding conforming to all the requirements of this standard.

8.1.4 Requirement for Fusion Welding

Materials for pipes and fittings suitable for fusion welding shall be classified as below based on their melt flow rate (MFR):

- a) Class A : MFR ≤ 0.3 g/10 min;
- b) Class B : 0.3 g/10 min < MFR ≤ 0.6 g/10 min;
- c) Class C : 0.6 g/10 min < MFR ≤ 0.9 g/10 min; and
- d) Class D : 0.9 g/10 min < MFR ≤ 1.5 g/10 min.

Only pipes and fittings made from materials of the same or adjacent MFR classes shall be fused together.

8.2 Sealing Ring

8.2.1 Elastomeric sealing rings shall be of any of the six hardness classes as per IS 5382. The manufacturer has to however specify the hardness class and application type of sealing ring that is being offered. The design of the profile of the sealing ring is

left to the manufacturer as long as the pipe with sealing ring meets the requirements of the standard.

Elastomeric sealing rings shall be free from substances that can have a detrimental effect on the performance of the pipes or fittings.

NOTE — A test report or conformity certificate may be obtained from the manufacturer of the sealing ring for conformity to IS 5382. The frequency of this test report or conformity certificate shall be once in three months.

8.2.2 The design of the profile and dimensions of the sealing ring is left to the manufacturer, as long as the pipe with the sealing ring meets the requirements of this standard. Where the design of the socket is such that the ring is not firmly fixed in position, the housing for the ring shall be so designed as to minimize the possibility of the ring being dislodged during insertion of the pipe (or spigot or fitting) to complete the joint.

9 DIMENSIONS

9.1 Dimensions of Pipes

9.1.1 Outside Diameters

The mean outside diameter of pipes shall be as per Table 2, as applicable.

Table 2 Mean Outside Diameters (Metric Series)

(Clauses 9.1.1 and 9.3.1)

All dimensions are in millimetres.

SI No.	Nominal Size, <i>DN/OD</i>	Nominal Outside Diameter, <i>d_n</i>	Mean Outside Diameter	
			<i>d_{em, Min}</i>	<i>d_{em, Max}</i>
(1)	(2)	(3)	(4)	(5)
i)	32	32	32.0	32.3
ii)	40	40	40.0	40.3
iii)	50	50	50.0	50.3
iv)	63	63	63.0	63.3
v)	75	75	75.0	75.4
vi)	80	80	80.0	80.4
vii)	90	90	90.0	90.4
viii)	100	100	100.0	100.4

ix)	110	110	110.0	110.4
x)	125	125	125.0	125.4
xi)	160	160	160.0	160.5
xii)	200	200	200.0	200.6
xiii)	250	250	250.0	250.8
xiv)	315	315	315.0	316.0

9.1.2 Effective Length

The effective length of a pipe shall not be less than that declared by the manufacturer and shall be measured as shown in Fig. 1.

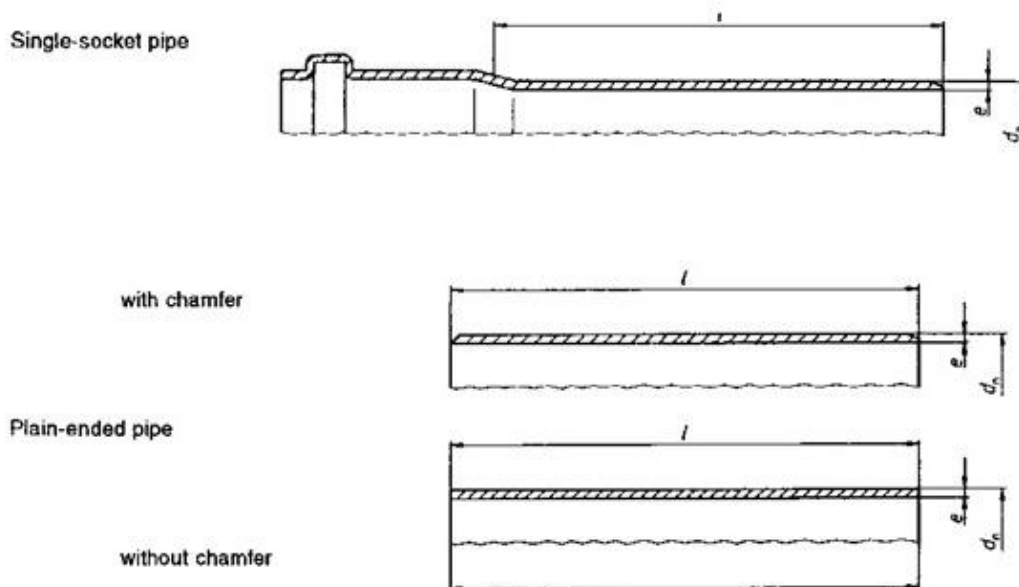

FIG. 1 EFFECTIVE LENGTH OF PIPES

9.1.3 Chamfering

If a chamfer is required, the angle of chamfering shall be between 15° and 45° to the axis of the pipe (see Fig 1). When pipes without chamfer are used, the pipe ends shall be de-burred.

The remaining wall thickness of the end of the pipe shall be at least $\frac{1}{3}$ of e_{min} .

9.2 Wall Thickness

The wall thickness, e shall conform to Table 3 as applicable, where for metric series a maximum wall thickness at any point up to $1.25 e_{min}$ is permitted, provided that the mean wall thickness, e_m is less than or equal to the specified $e_m Max$, where $e_m Max$

is the maximum permitted mean wall thickness.

Table 3 Wall Thicknesses for Pipes (Metric Series)

(Clauses 9.2 and 8.3.3)

All dimensions are in millimetres.

SI No.	Nominal Size, DN/OD	Nominal Outside Diameter, d_n	Pipe Series					
			S20 ¹⁾		S16		S14	
			Wall Thickness					
			e , <i>Min</i>	e_m , <i>Max</i>	e , <i>Min</i>	e_m , <i>Max</i>	e , <i>Min</i>	e_m , <i>Max</i>
(1)	(2)	(3)	(4)	(5)	(6)	(7)	(8)	(9)
i)	32	32	1.8	2.2	1.8	2.2	1.8	3.0
ii)	40	40	1.8	2.2	1.8	2.2	1.8	3.0
iii)	50	50	1.8	2.2	1.8	2.2	1.8	3.0
iv)	63	63	1.8	2.2	2.0	2.4	2.2	3.1
iv)	75	75	1.9	2.3	2.3	2.8	2.6	3.1
v)	80	80	2.0	2.4	2.5	3.0	2.8	3.3
vi)	90	90	2.2	2.7	2.8	3.3	3.1	3.7
vii)	100	100	2.5	3.0	3.2	3.8	3.5	4.1
viii)	110	110	2.7	3.2	3.4	4.0	3.8	4.4
ix)	125	125	3.1	3.7	3.9	4.5	4.3	5.0
x)	160	160	3.9	4.5	4.9	5.6	5.5	6.3
xi)	200	200	4.9	5.6	6.2	7.1	6.9	7.7
xii)	250	250	6.2	7.1	7.7	8.7	8.6	9.7
xiii)	315	315	7.7	8.7	9.7	10.9	10.8	12.1
¹⁾ Pipes suitable for Pipes suitable for used for rain water discharge and ventilation pipe work only and The pipe size DN 75mm and above in S20 Series can be used in waste discharge system and sewerage system.								

9.3 Dimensions of Fittings

9.3.1 Outside Diameters

The mean outside diameter, d_{em} of the spigot end shall conform to Table 2 as applicable.

9.3.2 Z-lengths

The Z-length(s) of fittings (see clause No.) shall be declared by the manufacturer.

NOTE — The Z-length of a fitting is intended to assist in the design of moulds and is not intended to be used for quality control purposes.

9.3.3 Wall Thicknesses

The minimum wall thickness, e_{min} of the body or the spigot end of a fitting shall conform to Table 5 or Table 6, as applicable, except that a reduction of 5 percent resulting from core shifting is permitted. In such a case the average of two opposite wall thicknesses shall be equal to or exceed the values given in Table 3, as applicable.

Where a fitting or adaptor provides for a transition between two nominal sizes, the wall thickness of each connecting part shall conform to the requirements for the applicable nominal size. In such a case, the wall thickness of the fitting body is permitted to change gradually from the one wall thickness to the other.

Where a sealing ring is located by means of a retaining cap or ring (see Fig. 2) the wall thickness in this area shall be calculated by addition of the wall thickness of the socket and the wall thickness of the retaining cap or ring at the corresponding places in the same cross-section.

The wall thickness of fabricated fittings, except for spigot end and socket may be changed locally by the fabrication process, provided that the minimum wall thickness of the body conforms to $e_{3, Min}$, as given in Table 5, as appropriate for the concerned pipe series.

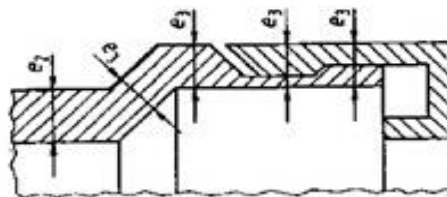

FIG. 2 EXAMPLE FOR CALCULATION OF THE WALL THICKNESS OF SOCKETS WITH RETAINING CAP

9.3.4 Dimensions of Sockets and Pipe Ends

9.3.4.1 Diameters and lengths

The diameters and lengths of ring seal sockets and spigot ends (see Fig. 3, Fig. 4 or Fig. 5) shall conform to Table 4 as applicable, and shall be in accordance with the

following conditions:

- a) Where sealing rings are firmly retained, the dimensions for the minimum value for A and the maximum value for C shall be measured to the effective sealing point (see Fig. 5 as an example). This point shall give a full sealing action.
- b) Where sealing rings are firmly retained, requirements for dimension B (see Fig. 4) do not apply.

Different designs of ring seal sockets (see Fig. 4) are permitted provided the joints conform to the requirements given in Table 4.

**Table 4 Diameters and Lengths of Ring Seal Sockets and Spigot Ends
(Metric Series)
(Clause 9.3.4.1)**

All dimensions are in millimetres

SI No.	Nominal Size	Nominal Outside Diameter,	Socket				Spigot End
			$d_{sm},$ Min	A, Min	B, Min	C, Max	
(1)	(2)	(3)	(4)	(5)	(6)	(7)	(8)
i)	32	32	32.3	24	5	18	42
ii)	40	40	40.3	26	5	18	44
iii)	50	50	50.3	28	5	18	46
iv)	63	63	63.3	31	5	18	49
v)	75	75	75.4	33	5	18	51
vi)	80	80	80.4	34	5	19	53
vii)	90	90	90.4	34	5	20	54
viii)	100	100	100.4	35	5	21	56
ix)	110	110	110.4	36	6	22	58
x)	125	125	125.4	38	7	26	64
xi)	160	160	160.5	41	9	32	73
xii)	200	200	200.6	45	12	40	85
xiii)	250	250	250.8	68	15	50	118
xiv)	315	315	316.0	81	19	63	144

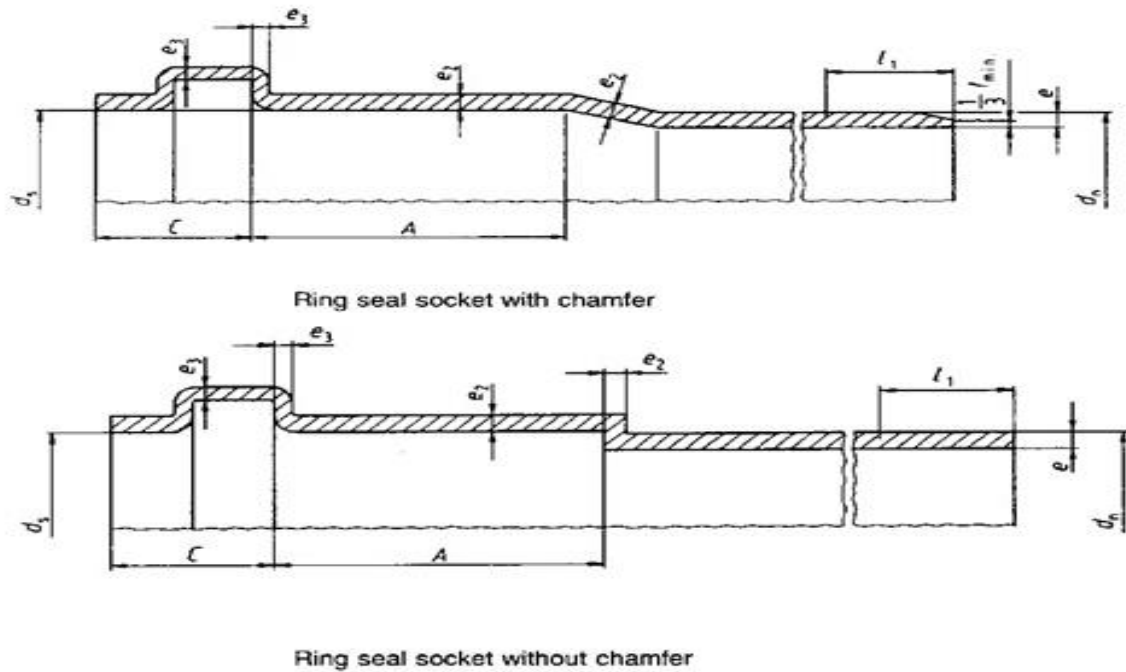

FIG. 3 DIMENSIONS OF SOCKETS AND SPIGOT ENDS FOR RING SEAL JOINTS

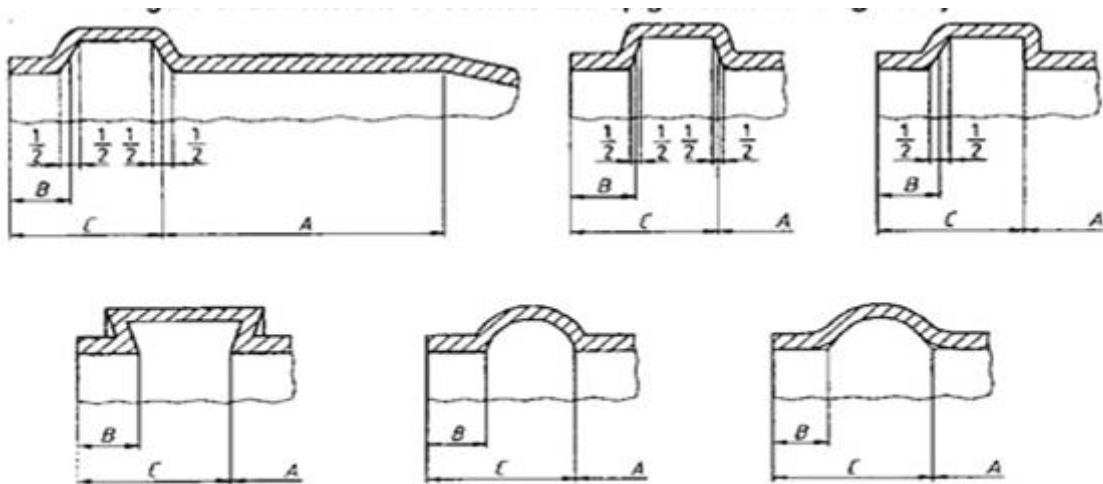

FIG. 4 TYPICAL GROOVE DESIGNS FOR RING SEAL SOCKETS

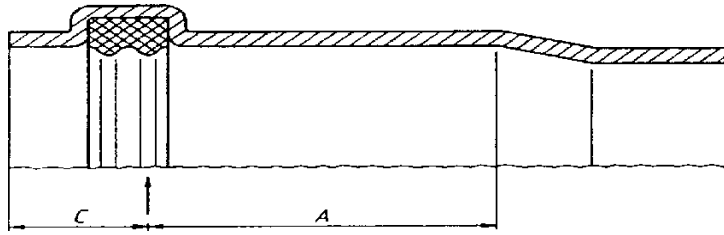

FIG. 5 EFFECTIVE SEALING POINT

9.3.4.2 Wall Thickness of Ring Seal Sockets

The wall thickness of the socket, e_2 and the wall thickness in the groove area, e_3 shall conform to Table 5, as applicable.

Table 5 Wall Thickness of Sockets (Metric Series)

(Clauses 9.3.3, 9.3.4.2 and 9.3.4.2)

All dimensions are in millimetres.

Sl No.	Nominal Size	Nominal Outside Diameter	Pipe Series					
			S 20 ¹⁾		S 16		S 14	
			Wall Thickness					
			e_2	e_3	e_2	e_3	e_2	e_3
(1)	(2)	(3)	(4)	(5)	(6)	(7)	(8)	(9)
i)	32	32	1.6	1.0	1.6	1.0	1.6	1.0
ii)	40	40	1.6	1.0	1.6	1.0	1.6	1.0
iii)	50	50	1.6	1.0	1.6	1.0	1.6	1.0
iv)	63	63	1.6	1.0	1.7	1.1	2.0	1.3
v)	75	75	1.7	1.1	2.1	1.3	2.4	1.5
vi)	80	80	1.7	1.1	2.3	1.4	2.6	1.6
vii)	90	90	2.0	1.3	2.6	2.1	2.8	2.4
viii)	100	100	2.3	1.4	2.8	2.4	3.2	2.7
ix)	110	110	2.4	1.5	3.1	2.6	3.5	2.9
x)	125	125	2.8	1.8	3.6	3.0	3.9	3.3
xi)	160	160	3.5	2.2	4.5	3.7	5.0	4.2

xii)	200	200	4.4	2.7	5.6	4.7	-	-
xiii)	250	250	-	-	7.0	5.8	-	-
xiv)	315	315	-	-	8.8	7.3	-	-
¹⁾ Pipes suitable for used for rain water discharge and ventilation pipe work only and The pipe size DN 75mm and above in S20 Series can be used in waste discharge system and sewerage system								

9.3.5 Dimensions of Pipe Ends for Fusion Joints

The mean outside diameter, d_{em} and the wall thickness, e of pipes with plain ends intended to be used for fusion joints shall conform to the same pipe series S, as specified in this standard.

9.3.6 Types of Fittings

9.3.6.1 This standard is applicable for the following types of fittings. Other designs of fittings are permitted.

- a) Bends (see Figs. 6, 7, 8, 9, 10 and 11);
 - i) upswept or swept angle;
 - ii) spigot/socket or socket/socket; and
 - iii) butt fused from segments.

The fixed nominal angle, α of bends shall be 15°, 22.5°, 30°, 45°, 67.5°, 80° or 87.5° and 90°.

- b) Branches and reducing branches (branching single or multiple) (see Fig. 12, 13, 14, 15, 16 and 17)
 - i) upswept or swept angle; and
 - ii) spigot/socket or socket/socket.

The fixed nominal angle, α of branches and reducing branches should be 45°, 67.5° or 87.5° to 90°. If other angles are required, they shall be agreed between the manufacturer and purchaser and be identified accordingly.

- c) Reducers (see Fig. 18);
- d) Access fittings (see Fig. 19);

The inside diameter of the cleaning hole shall be as specified by the manufacturer.

- e) Couplers
 - i) Double socket (see Fig. 20);
 - ii) Repair collar (see Fig. 21);
- f) Push-fit socket for fusion for pipe ends (see Fig. 22)

g) Plugs (see Fig. 23).

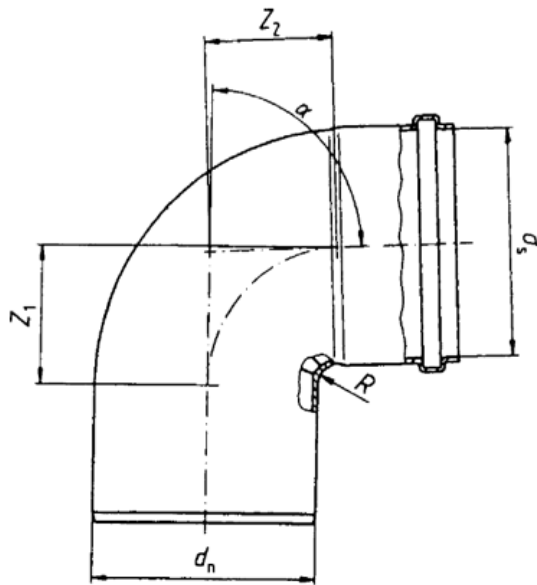

FIG. 6 BEND WITH SINGLE SOCKET

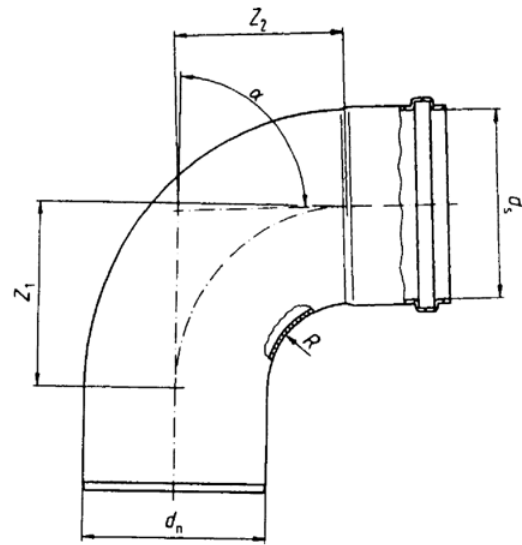

FIG. 7 BEND WITH SINGLE SOCKET
(SWEPT)

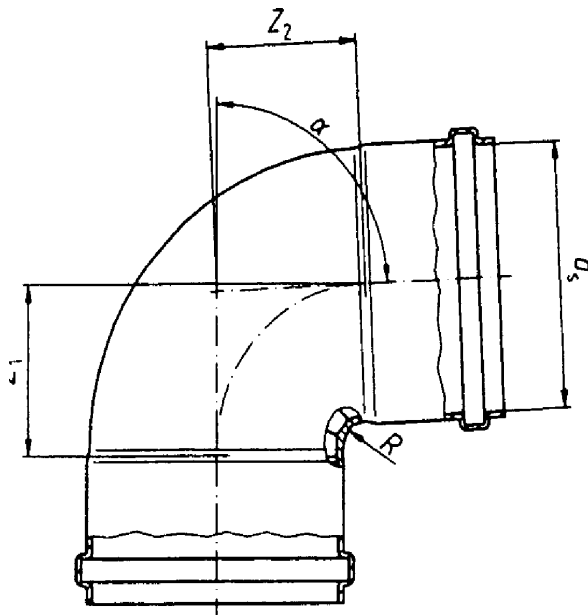

FIG. 8 BEND WITH ALL SOCKETS
(UNSWEPT)

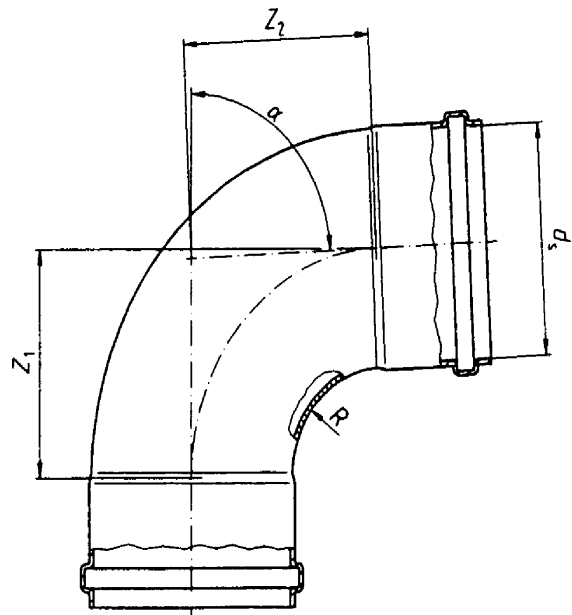

FIG. 9 BEND WITH ALL SOCKETS
(SWEPT)

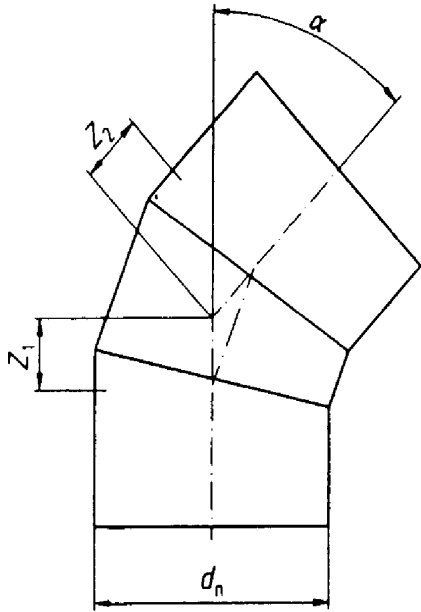

FIG. 10 BEND, FUSED FROM SINGLE

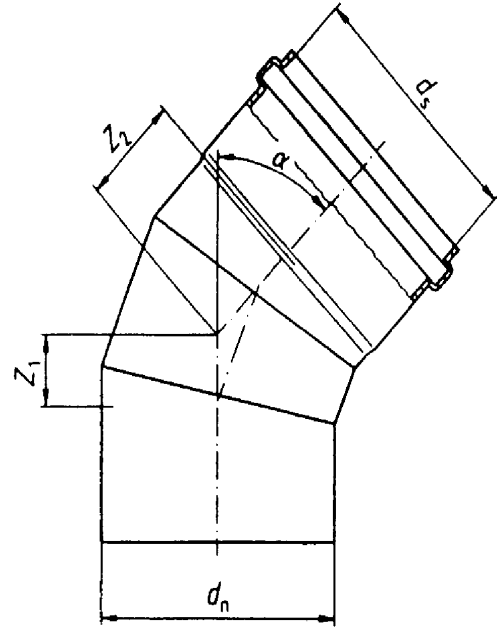

FIG. 11 BEND WITH

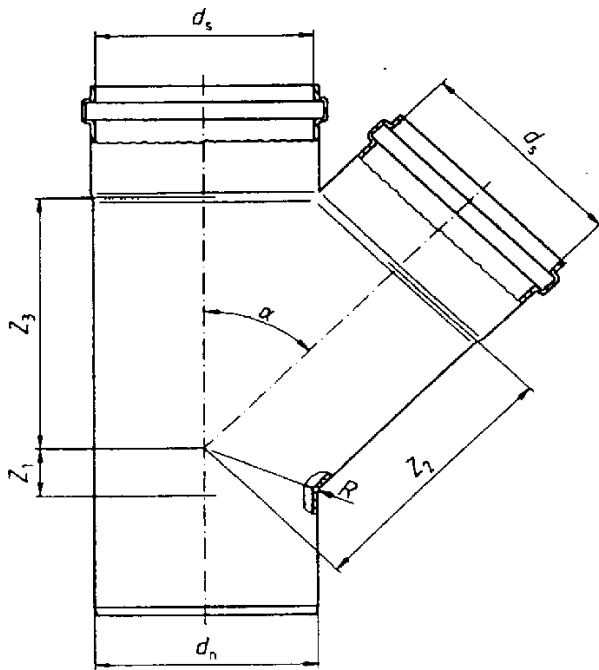

FIG. 12 BRANCH (UNSWEPT)

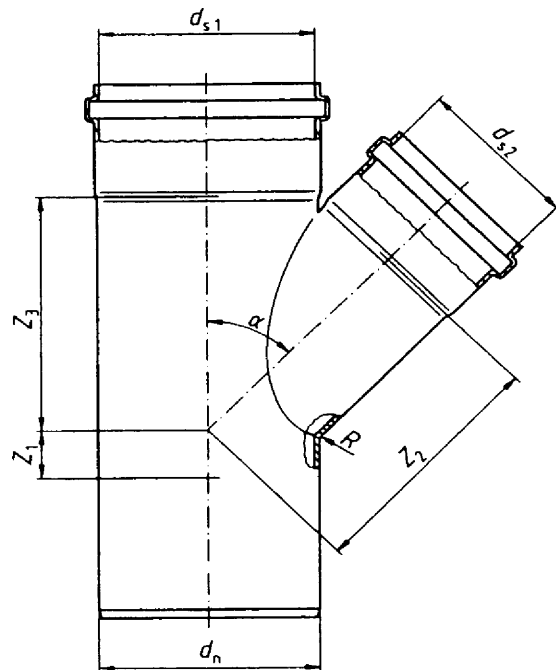

FIG. 13 REDUCING BRANCH (UNSWEPT)

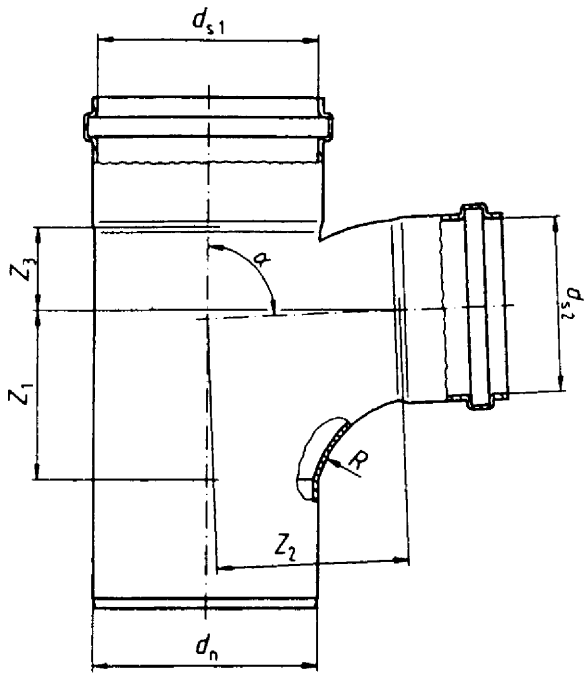

FIG. 14 REDUCING BRANCH
 (SWEPT)

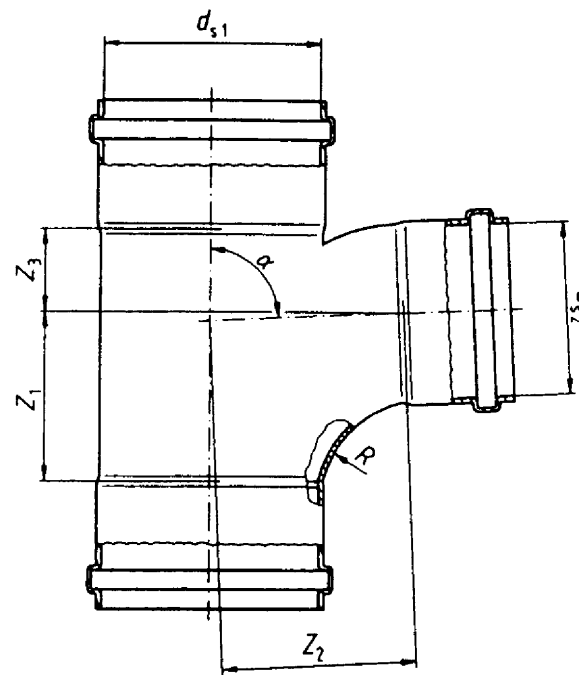

FIG. 15 REDUCING BRANCH WITH
 ALL SOCKETS

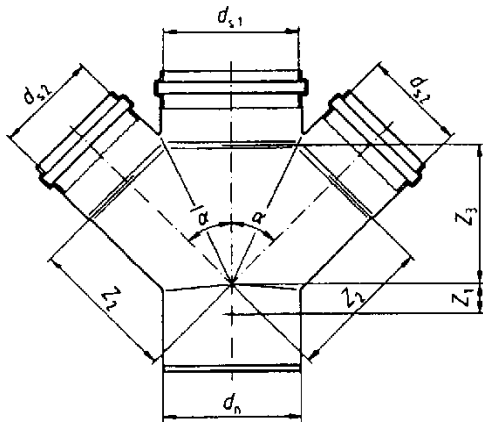

FIG. 16 DOUBLE BRANCH

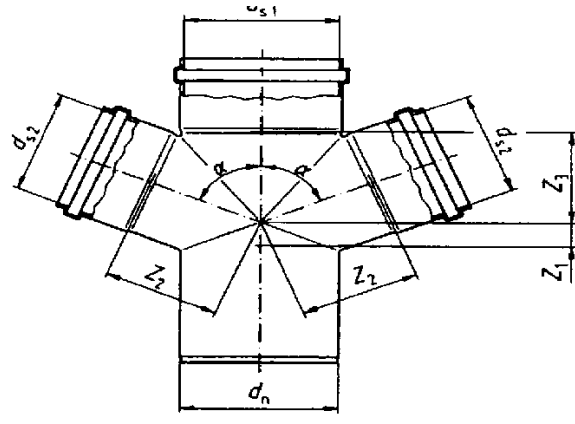
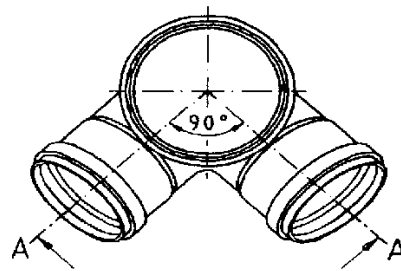

FIG. 17 ANGULAR DOUBLE BRANCH



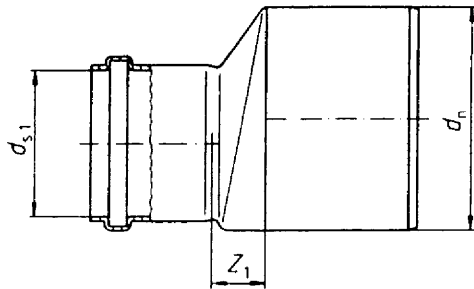

FIG. 18 REDUCER

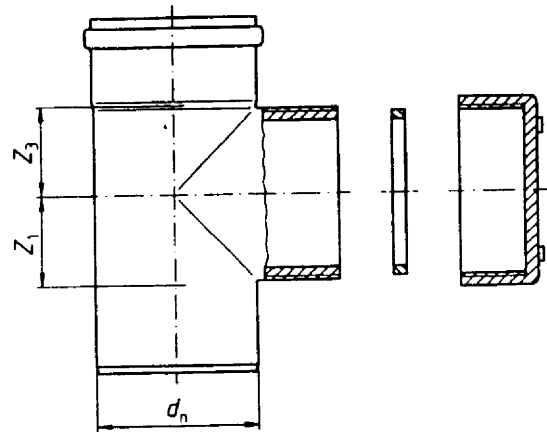

FIG. 19 ACCESS FITTING WITH

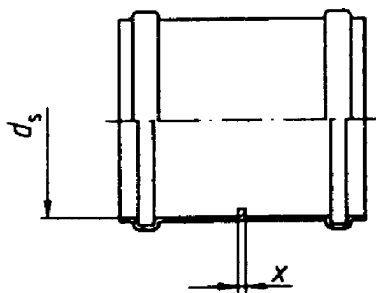

FIG. 20 DOUBLE SOCKET

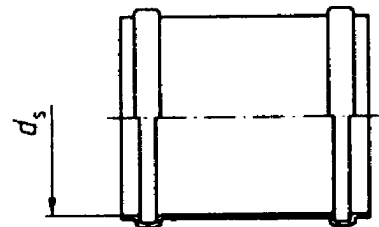

FIG. 21 REPAIR

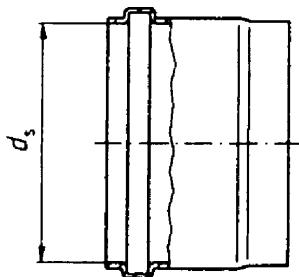

FIG. 22 PUSH-FIT SOCKET FOR FUSION OF PIPE ENDS

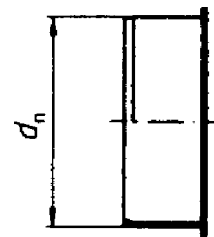

FIG. 23 PLUG

10 PHYSICAL CHARACTERISTICS

10.1 Appearance

When viewed without magnification, the internal and external surfaces of pipes and fittings shall be smooth, clean and free from grooving, blistering, impurities and pores and any other surface irregularity likely to prevent their conformance to this standard. Pipe's ends shall be cleanly cut and the ends of pipes and fittings shall be square to each axis.

10.2 Other Physical Characteristics

When tested in accordance with the test methods as specified in Table 6 using the indicated parameters, the pipe shall have physical characteristics conforming to the

requirements given in Table 6.

Table 6 Physical Characteristics of Pipes
(Clauses 9.3.3 and 10.2)

SI No.	Characteristic	Requirements	Test Parameters		Test Method
			(4)	(5)	
(1)	(2)	(3)	(4)	(5)	
i)	Longitudinal reversion ¹⁾	2 percent The pipe shall exhibit no bubbles or cracks	Test temperature Immersion time Liquid	(150 ± 2) °C 30 min	IS 12235 Part 6
			Or		
			Test temperature Immersion time Air	(150 ± 2) °C 60 min	IS 12235 Part 6
ii)	Melt mass-flow rate (MFR-value)	Permitted max. deviation when processing the compound into a pipe: 0.2 g/10 min	Condition 12: Test temperature Reference time Loading mass	230 °C 10 min 2.16 kg	IS 13360 (Part 4/ Sec 1)
iii)	Density ²⁾	Pipe	> 0.88	27 °C	IS 13360 (Part 3/ Sec 1)
¹⁾ The choice of method A or method B is in the responsibility of the manufacturer. However, the method adopted should be reported.					
²⁾ The manufacturer has to declare the base density for the material which comply the requirement of above Table, however the variation of ± 10percent is allowed on declared value when tested on finished pipe sample.					

10.3 Other Physical Characteristics of Fittings

When tested in accordance with the test methods as specified in Table 7 and Table 8 using the indicated parameters, the fittings shall have physical characteristics conforming to the requirements given in Table 7 and Table 8, as applicable.

Table 7 Physical Characteristics of Fittings
(Clause 10.3)

Sl. No.	Characteristics	Requirement	Test Parameters		Test Method
			(4)	(5)	
(1)	(2)	(3)	(4)		(5)
i)	Effects of heating	1), 2), 3)	Test Temperature	(150 ± 2) °C	Annex D of IS 16098 (Part 2)
			Heating time	30 min	
ii)	Density ⁴⁾		> 0.88	27° C	IS 13360 (Part 3/ Sec 1)
<p>¹⁾ The depth of cracks, delamination or blisters shall not be more than 20 percent of the wall thickness around the injection point(s). No part of the weld line shall be open to a depth of more than 20 percent of the wall thickness.</p> <p>²⁾ When fittings are manufactured from Pipes the Pipes shall conform to the requirements given in Table 2 and Table 3.</p> <p>³⁾ Mouldings that are used for fabricated fittings may be tested separately.</p> <p>⁴⁾ The manufacturer has to declare the base density for the material which comply the requirement of above table, however the variation of ± 10percent is allowed on declared value on finished fitting sample</p>					

Table 8 Physical Characteristics of Fabricated Fittings
(Clauses 10.3 and 11)

Sl No.	Characteristic	Requirement	Test Parameters		Test Method
			(4)	(5)	
(1)	(2)	(3)	(4)		(5)
i)	Water Tightness ¹⁾	No leakage	Water pressure Duration	0.5 bar ²⁾ 1 min	Annex F of IS 16098 (Part 2)
<p>¹⁾ Only for fabricated fittings made from more than one piece. A sealing ring retaining mean is not considered as a piece.</p> <p>²⁾ 1 bar = 100 kPa</p>					

11 MECHANICAL CHARACTERISTICS OF PIPES GENERAL CHARACTERISTICS

When tested in accordance with the test method as specified in Table 9 using the indicated parameters, the pipe shall have general mechanical characteristics conforming to the requirements given in Table 8.

The mass and fall height of striker for determining the impact resistance (round-the-clock method) as specified in Table 10 as applicable.

Table 9 General Mechanical Characteristics of Pipes
(Clause 11)

Sl. No.	Characteristic	Requirement	Test Parameters		Test methods
(1)	(2)	(3)	(4)		(5)
i)	PP-copolymer: Impact resistance ¹⁾ (round-the-clock method)	TIR10 percent	Mass of striker	Table 10	IS 12235 : 2004 (Part 9)
			Fall of height of striker	Table 10	
			dn < 110 mm	d 25	
			dn ≥ 110 mm	d 90	
			Conditioning medium	Water or air	
			Conditioning temperature	(0 ± 1) °C	
			Conditioning period	60 min	
			Sampling procedure	As per plan	
ii)	PP-H: Impact resistance (round-the-clock method)	TIR10 percent	Mass of striker	Table 10	IS 12235 : 2004 (Part 9)
			Fall of height of striker	Table 10	
			dn < 110 mm	d 25	
			dn ≥ 110 mm	d 90	
			Conditioning medium	Air	
			Conditioning temperature	(26 ± 3) °C	
			Conditioning period	60 min	
			Sampling procedure	As per plan	

**Table 10 Masses and Fall Heights of Striker for Impact Resistance
(Round-the-Clock Method) (Metric Series)**
(Clause 11)

All Dimensions in millimetres

SI No.	Nominal Size DN/OD	Nominal Outside Diameter dn	Mass of Striker kg	Fall Height of Striker
(1)	(2)	(3)	(4)	(5)
i)	32	32	0,5	600
ii)	40	40	0,5	800
iii)	50	50	0,5	1 000
iv)	63	63	0.8	1 000
v)	75	75	0.8	1 000
vi)	80	80	0.8	1 000
vii)	90	90	0.8	1 200
viii)	100	100	0.8	1 200
ix)	110	110	1.0	1 600
x)	125	125	1.25	2 000
xi)	160	160	1.6	2 000
xii)	200	200	2.0	2 000
xiii)	250	250	2.5	2 000
xiv)	315	315	3.2	2 000

11.1 Additional Characteristics

Pipes made from PP-copolymers intended to be used in areas where installation is usually carried out at temperatures below -10 °C, shall additionally conform to the requirements of an impact test (staircase method) as specified in Table 11.

The Pipes shall be marked in accordance with Table 14.

Table 11 Additional Mechanical Characteristics of Pipes
(Clause 11.1)

Sl. No.	Characteristic	Requirement	Test Parameters		Test methods
(1)	(2)	(3)	(4)		(5)
i)	Impact resistance ¹⁾ (staircase method)	H 50 ≥ 1m max one break below 0.5 m	Conditioning and test temperature	(0 to 1) °C	As per Annex-C IS xxxx Part 2
			Type of striker	d 90	
			Mass of striker:	In kg:	
			32 mm ≤ dn ≤ 41 mm	1.25	
			50 mm ≤ dn ≤ 63 mm	2.0	
			75 mm ≤ dn ≤ 80 mm	2.5	
			90 mm ≤ dn ≤ 100 mm	3.2	
			110 mm dn	4.0	
			125 mm dn	5.0	
			160 mm dn	8.0	
			200 mm dn	10.0	
			> 200 mm dn	12.5	
1) For PP-copolymer only.					

11.2 Performance Requirements

When tested in accordance with the test methods as specified in Table 12 using the indicated parameters, the joints and the system shall have fitness for purpose characteristics conforming to the requirements given in Table 12.

Table 12 Fitness for Purpose Characteristics of the System
(Clause 11.2)

Sl No.	Characteristic	Requirements	Test Parameters
(1)	(2)	(3)	(4)
i)	Water tightness ¹⁾	No leakage	IS 16098 (Part 2)
ii)	Airtightness ¹⁾	No leakage	IS 16098 (Part 2)

12 MARKING**12.1 General**

Marking elements shall be labelled, printed or formed directly on the component in such a way that after storage, weathering, handling and installation, the required legibility is maintained.

NOTE — The manufacturer is not responsible for marking being illegible, due to actions caused during installation and use such as painting, scratching, covering of the components or by use of detergents, etc on the components, unless agreed or specified by the manufacturer.

Marking shall not initiate cracks or other types of defects which adversely influence the performance of the pipe or fitting.

If printing is used, the coloring of the printed information shall differ from the basic coloring of the pipe or fitting.

The size of the marking shall be such that the marking is legible without magnification.

12.2 Minimum Required Marking of Pipes

The minimum required marking of Pipes shall conform to Table 14 shall be marked at intervals of maximum 1 m, at least once per pipe. Pipes with a length less than 1 m may be marked with a label at least once per pipe.

Table 14 Minimum Required Marking of Pipes
(Clauses 11.1 and 12.2)

SI No.	Aspects	Marking or Symbols	Minimum Durability of Legibility of Marking
(1)	(2)	(3)	(4)
i)	Number of the standard	IS xxxx/IS logo	A
ii)	a) Manufacturer's name and/or trade mark	xxxx	a
	b) Nominal size	e.g. dn 110	a
	c) Minimum wall thickness	e.g. 3.4	a
	d) Material ¹⁾	PP or PP-H	a
	e) Pipe series	e.g. S 16	a
	f) Manufacturer's information		a

	1) Pipes which are marked "PP" are made from PP-copolymer. Pipes made from PP-Homopolymer shall be marked "PP-H".
	2) For Pipes intended for fusion.
	3) For providing traceability the following details shall be given:
	a) the production period (year and month) in Fig or in code;
	b) a name or code for the production site if the manufacturer is producing at different sites.

12.3 Minimum Required Marking of Fittings

The minimum required marking of fittings shall conform to Table 15, whereby the manufacturer's information can be either on the fitting or on the packaging. If the manufacturer's information is on the packaging it shall be determined by national requirements.

Table 15 Minimum Required Marking of Fittings
(Clause 12.3)

SI No.	Aspects	Marking or Symbols	Minimum Durability of Legibility of Marking
(1)	(2)	(3)	(4)
i)	a) Number of the standard	IS xxxx	b
	b) Manufacturer's name and/or trade mark	xxxx	a
	c) Nominal Size	e.g. DN 110	a
	d) Nominal Angle	e.g. 67.5°	b
	e) Material ¹⁾	PP or PP-H	a
	f) Minimum wall thickness or pipe series	e.g. 3.4 or S 16	a
	g) Manufacturer's information	³⁾	b
	Fittings which are marked "PP" are made from PP-copolymer		
	Fittings made from PP-homopolymer shall be marked " PP-H "		

	For fittings intended for fusion;
	For providing traceability the following details shall be given;
	a) the production period (year) in Fig or in code; and
	b) a name or code for the production site if the manufacturer is producing at different sites

12.4 Installation of Piping Systems

For the installation of Pipes and fittings conforming to this standard, national and/or local requirements and relevant codes of practice apply.

In addition, the pipe manufacturer may shall give a recommended practice for installation which refers to transport, storage and handling of the pipes and fittings as well as to the installation in accordance with the applicable national and/or local instructions.

For external above ground application additional requirements depending on the climate shall be agreed between the manufacturer and the user.

Due to the limited impact strength at low temperatures, pipes and fittings made from PP-Homopolymer are not intended to be installed at temperatures below +5 °C.