



भारतीय मानक ब्यूरो BUREAU OF INDIAN STANDARDS

MANAK BHAVAN, 9 BAHADUR SHAH ZAFAR MARG, NEW DELHI 110002

Phone: + 91 11 23230131, 23233375, 23239402 Extn 8406, 23608406; Website: www.bis.gov.in

व्यापक परिचालन मसौदा

हमारा संदर्भ: सीईडी 50/टी-95

09 जून 2021

तकनीकी समिति : प्लास्टिक पाइपिंग सिस्टम विषय समिति, सीईडी 50

प्राप्तकर्ता :

1 सिविल इंजीनियरी विभाग परिषद के सभी सदस्य
2 प्लास्टिक पाइपिंग सिस्टम विषय समिति, सीईडी 50, पोलीओलीफिंस एवं जीआरपी पाइपिंग सिस्टम उपसमिति सीईडी 50:1, पीवीसी एवं एबीएस पाइपिंग सिस्टम उपसमिति, सीईडी 50:2 एवं यूपीवीसी कॉलम पाइप के लिए कार्य समूह, सीईडी, 50:WG2 के सभी सदस्य

3 रुचि रखने वाले अन्य निकाय।

महोदय/महोदया,

निम्नलिखित मसौदा संलग्न है:

प्रलेख संख्या	शीर्षक
सीईडी 50 (15770)WC	बोरवेल/नलकूप के लिए असुघटित पॉलीविनायल क्लोराइड (पीवीसी-यू) के चूड़ीदार कॉलम पाइप की विशिष्टी का भारतीय मानक मसौदा (आई सी एस संख्या 23.040.20)

कृपया इस मसौदे का अवलोकन करें और अपनी सम्मतियाँ यह बताते हुए भेजे कि यह मसौदा प्रकाशित हो तो इन पर अमल करने में, आपको व्यवसाय अथवा कारोबार में क्या कठिनाइयाँ आ सकती हैं।

सम्मतियाँ भेजने की अंतिम तिथि: **09 जुलाई 2021**

सम्मति यदि कोई हो तो कृपया अधोहस्ताक्षरी को ई मेल द्वारा madhurima@bis.gov.in पर संलग्न फॉर्मेट में भेजें।

यदि कोई सम्मति प्राप्त नहीं होती है अथवा सम्मति में केवल भाषा संबंधी त्रुटि हुई तो उपरोक्त प्रलेख को यथावत अंतिम रूप दे दिया जाएगा। यदि सम्मति तकनीकी प्रकृति की हुई तो विषय समिति के अध्यक्ष के परामर्श से अथवा उनकी इच्छा पर आगे की कार्यवाही के लिए विषय समिति को भेजे जाने के बाद प्रलेख को अंतिम रूप दे दिया जाएगा।

यह प्रलेख भारतीय मानक ब्यूरो की वेबसाइट www.bis.gov.in पर भी उपलब्ध हैं।

धन्यवाद।

भवदीय

ह/-

(संजय पंत)

प्रमुख (सिविल इंजीनियरिंग)

संलग्न: उपरिलिखित



भारतीय मानक ब्यूरो BUREAU OF INDIAN STANDARDS

MANAK BHAVAN, 9 BAHADUR SHAH ZAFAR MARG, NEW DELHI 110002
Phone: + 91 11 23230131, 23233375, 23239402 Extn 8406, 23608406; Website: www.bis.gov.in

DRAFT IN
WIDE CIRCULATION

DOCUMENT DESPATCH ADVICE

Reference	Date
CED 50/T-95	09 June 2021

TECHNICAL COMMITTEE:

PLASTIC PIPING SYSTEMS SECTIONAL COMMITTEE, CED 50

ADDRESSED TO:

1. All Members of Civil Engineering Division Council, CEDC
2. All Members of Plastic Piping System Sectional Committee, CED 50, Polyolefins and GRP Piping System Subcommittee, CED 50:1, PVC and ABS Piping System Subcommittee, CED 50:2, and Working Group for UPVC Column Pipes, CED 50:WG2
3. All other interests

Dear Sir/Madam,

Please find enclosed the following draft:

Doc. No.	Title
CED 50 (15770)WC	Draft Indian Standard Unplasticized polyvinyl chloride (PVC-U) threaded column pipes for borewells/tubewells – Specification (ICS No. 23.040.20)

Kindly examine the draft and forward your views stating any difficulties which you are likely to experience in your business or profession, if this is finally adopted as National Standard.

Last Date for comments: 09 July 2021

Comments if any, may please be made in the enclosed format and emailed at madhurima@bis.gov.in.

In case no comments are received or comments received are of editorial nature, you will kindly permit us to presume your approval for the above document as finalized. However, in case comments, technical in nature are received, then it may be finalized either in consultation with the Chairman, Sectional Committee or referred to the Sectional Committee for further necessary action if so desired by the Chairman, Sectional Committee.

The document is also hosted on BIS website www.bis.gov.in.

Thanking you,

Yours faithfully,

Sd/-

(Sanjay Pant)
Head (Civil Engg.)

Encl: As above

BUREAU OF INDIAN STANDARDS

DRAFT FOR COMMENTS ONLY

(Not to be reproduced without the permission of BIS or used as a Standard)

Draft Indian Standard

**UNPLASTICIZED POLYVINYL CHLORIDE (PVC-U) THREADED COLUMN PIPES
FOR BOREWELLS/TUBEWELLS – SPECIFICATION**
(ICS No. 23.040.20)

Plastic Piping System
Sectional Committee, CED 50

Last date for Comments:
09 July 2021

Plastic Piping System Sectional Committee, CED 50

FOREWORD

(Formal clauses to be added later)

This Indian Standard has been formulated to cover requirements and test methods for unplasticized polyvinyl chloride (PVC-U) threaded column pipes for use with jet and submersible pumps in borewells/tubewells.

It is the responsibility of the purchaser or the supplier to make the appropriate selection of pipes taking into account their particular requirements and any relevant national guidelines or regulations. Relevant guidelines for installation practices should be followed.

For the purpose of deciding whether a particular requirement of the standard is complied with the final value observed or calculated, expressing the result of a test or analysis, shall be rounded off in accordance with IS 2:1960 'Rules for rounding off numerical values (*revised*)'. The number of significant places retained in the rounded off value should be the same as that of the specified value in this standard.

BUREAU OF INDIAN STANDARDS

DRAFT FOR COMMENTS ONLY

(Not to be reproduced without the permission of BIS or used as a Standard)

Draft Indian Standard

**UNPLASTICIZED POLYVINYL CHLORIDE (PVC-U) THREADED COLUMN PIPES
FOR BOREWELLS/TUBEWELLS – SPECIFICATION**

Plastic Piping System
Sectional Committee, CED 50

Last date for Comments:
09 July 2021

1 SCOPE

1.1 This standard covers the requirements of unplasticized polyvinyl chloride (PVC-U) threaded column pipes of the following types and sizes, for use with jet or submersible pumps in borewells/tubewells for water supply:

- a) bell ended (socketed) type with external thread at spigot end and internal thread at bell (socket) end, of nominal sizes 25 mm, 32 mm and 40 mm; and
- b) coupler joint type with external threads at both ends, connected with coupler, of nominal sizes 25 mm to 150 mm.

1.2 These pipes are recommended for water temperatures ranging from 1°C to 45°C.

2 REFERENCES

The standards listed below, contain provisions, which through reference in this text, constitute provisions of this standard. At the time of publication, the editions indicated were valid. All standards are subject to revision and parties to agreements based on this standard are encouraged to investigate the possibility of applying the most recent editions of the standards indicated below:

<i>IS No.</i>	<i>Title</i>
4669 : 1968	Methods of tests for polyvinyl chloride resins
4905 : 2015/ ISO 24153 : 2009	Random sampling and randomization procedures (<i>first revision</i>)
4985 : 2021	PVC pipes for water supplies — Specification (<i>fourth revision</i>)

10148 : 1982	Positive list of constituents of polyvinyl chloride and its copolymers for safe use in contact with foodstuffs, pharmaceuticals and drinking water
10151 : 2019	Polyvinyl chloride (PVC) and its copolymers for its safe use in contact with foodstuffs, pharmaceuticals and drinking water — Specification (<i>first revision</i>)
12235	Thermoplastics pipes and fittings — Methods of test (<i>first revision</i>)
(Part 1) : 2004	Measurement of dimensions
(Part 2) : 2004	Determination of Vicat softening temperature
(Part 4) : 2004	Determining the detrimental effect on the composition of water
(Part 9) : 2004	Resistance to external blows (impact resistance) at 0° C (round the-clock method)
(Part 8/Sec 1) : 2004	Resistance to internal hydrostatic pressure, Section 1 Resistance to internal hydrostatic pressure at constant internal water pressure
(Part 10) : 2004	Determination of organotin as tin aqueous solution
(Part 11) : 2004	Resistance to dichloromethane at specified temperature
(Part 13) : 2004	Determination of tensile strength and elongation
(Part 14) : 2004	Determination of density/relative density (specific gravity)
(Part 19) : 2004	Flattening Test

3 TERMINOLOGY

For the purpose of this standard, the following definitions shall apply.

3.1 Column Pipes — Pipes with external threads at both ends, or with external thread at one end and internal thread at the other end, for carrying out ground water with jet/submersible pump from borewell/tubewell.

3.2 Column Pipe Couplers — Cut piece of pipe with internal threads at both ends to assemble/join the column pipes.

3.3 Nominal Size (DN) — The numerical designation for the size of the pipe other than a pipe designated by thread size, which is a convenient round number approximately equal to the manufactured dimension, in mm.

3.4 Nominal Outer Diameter (d_o) — The specified outside diameter, in mm, assigned to a nominal size.

3.5 Mean Outer Diameter (d_{em}) — The quotient of the outer circumference of a pipe and 3.142 (π) in any cross-section, rounded off to the next higher 0.1 mm.

3.6 Minimum Mean Outer Diameter ($d_{em, Min}$) — The minimum value for the mean outside diameter as specified for a given nominal size.

3.7 Maximum Mean Outer Diameter ($d_{em, Max}$) — The maximum value for the mean outside diameter as specified for a given nominal size.

3.8 Outer Diameter at Any Point (d) — The value of the measurement of the outer diameter of a pipe through its cross-section at any point of the pipe, rounded off to next higher 0.1 mm.

3.9 Out-of-Roundness (Ovality) — The difference between the measured maximum and the measured minimum outside diameter in the same cross-section of the pipe.

3.10 Nominal Wall Thickness (e_{ne} and e_{nb}) — A numerical designation of the wall thickness of a component which is a convenient round number, approximately equal to the manufacturing dimensions, in mm.

NOTE — e_{nb} and e_{ne} are nominal wall thickness of barrel (thin portion) and end side (thick portion), respectively.

3.11 Wall Thickness at Any Point (e_e and e_b) — The value of the measurement of the wall thickness at any point around the circumference of the pipe, rounded off to the next higher 0.1 mm.

NOTE — e_b and e_e are wall thickness at any point of barrel (thin portion) and end side (thick portion), respectively.

3.12 Mean Wall Thickness (e_{me} and e_{mb}) — The arithmetical mean of at least four measurements regularly spaced around the circumference and in the same cross-section of the pipe, including the measured minimum and the measured maximum values of the wall thickness in that cross-section and rounded off to the next higher 0.1 mm.

NOTE — e_{mb} and e_{me} are mean wall thickness of barrel (thin portion) and end side (thick portion), respectively.

3.13 Tolerance — The permitted variation of the specified value of a quantity, expressed as the difference between the permitted maximum and the permitted minimum value.

3.14 Working Pressure (PN) — The numerical designation of a pipe related to the mechanical characteristics of that pipe used for reference purposes. For plastic piping

systems, it corresponds to the allowable operating pressure, in bar, conveying water at 27°C.

3.15 Allowable Operating Pressure (PFA) — The maximum hydrostatic pressure excluding surge which is allowed in continuous use with water within the temperature range concerned. It is calculated using the following equation:

$$PFA = f_T \times PN$$

Where,

f_T = derating factor depending on water temperature; and
PN = working pressure.

NOTE — In cases where a further derating (or uprating) factor depending on the application is required,

$$PFA = f_A \times f_T \times PN$$

Where,

f_A = factor depending on the application.

3.16 Hydrostatic Stress (σ) — The stress induced in the wall of a pipe when a pressure is applied using water as a medium. The hydrostatic stress is related to the applied pressure, P , the wall thickness of thin portion at any point, e , and the mean outside diameter, d_{em} , of a pipe and calculated using the following approximation equation;

$$\sigma = \frac{P(d_{em} - e)}{2e}$$

where σ and P are in same units.

3.17 Bell End Pipes — Pipes with bell and spigot end, in which female (internal) thread is provided at bell end and male (external) thread at spigot end for connection of pipes.

4 COMPOSITION

4.1 The material from which the pipe is produced shall consist substantially of unplasticized polyvinylchloride to which may be added only those additives that are needed to facilitate production of sound and durable pipe of good surface finish and mechanical strength under conditions of use. None of these additives shall be used, separately or together, in quantities sufficient to constitute a toxic, organoleptic or microbial growth hazard or to materially impair the fabrication or welding properties of the pipe, or to impair the chemical, physical or mechanical properties (in particular long-term mechanical strength and impact strength) as defined in this standard. The additives to be used shall be selected from IS 10148 and shall be uniformly dispersed.

4.1.1 The monomer content (VCM content) in the resin shall be within the limits specified in **4.4.1** of IS 10151, when tested as per Annex A of IS 10151.

4.1.2 The composition shall be based on PVC resin having a K-value of 64 or greater, when tested in accordance with IS 4669.

NOTE — A test report or certificate of conformity may be obtained from the manufacturer for the VCM content (see 4.1.1) and K-value (see 4.1.2) of the resin being used, unless the same is tested in an independent laboratory. The frequency of this test report or certificate of conformity shall be once in every three months.

4.2 The addition of not more than 5 percent of the manufacturer’s own rework material conforming to this standard is permissible. No other rework material shall be used.

5 COLOUR

The pipe shall be of regular ivory white colour throughout. Slight colour deviation is permissible.

6 CLASSIFICATION

The pipes shall be classified by pressure ratings (working pressures) at 27 °C as per Table 1. The maximum depth of installation of column pipes as given in Table 1 is for guidance, and has to be suitably decided considering other parameters also, such as hanging weight and depth of submergence.

Table 1 CLASSIFICATION OF COLUMN PIPES
(Clause 6)

Sl No.	Class	Working Pressure (PN)	Recommended Maximum Depth of Installation
(1)	(2)	MPa (kg/cm ²) (3)	m (4)
i)	Class 1	1.0 (10)	100
ii)	Class 2	1.25 (12.5)	125
iii)	Class 3	1.5 (15)	150
iv)	Class 4	2.0 (20)	200
v)	Class 5	2.5 (25)	250
vi)	Class 6	3.5 (35)	350

The maximum safe working stress considered is at 14 MPa at 27 °C.

7 DIMENSIONS

7.1.1 The diameters and wall thicknesses of unthreaded column pipes with thick-thin portion shall be as given in Table 2 and Table 3 read with Fig. 1A and Fig. 1B. The dimensional details of column pipe couplers shall be as given in Table 4 read with Fig. 1C. The threads on column pipes and column pipe coupler are shown in Fig. 1D and Fig. 1E, respectively. The dimensional details of bell-ended pipes shall be as given in Table 4 read with Fig. 2. Belling dimensions of pipe shall be as per manufacturer’s design or as per the mutual agreement between the manufacturer and the purchaser.

7.1.2 Mean outer diameter and outer diameter at any point of unthreaded column pipes shall be measured according to IS 12235 (Part 1). The pipe diameter shall be measured at the thick end portion of the pipe.

7.1.3 Wall thickness of unthreaded column pipes shall be measured in accordance with the method given in IS 12235 (Part 1).

7.1.4 Nominal effective length of column pipe shall be minimum 3 000 mm. The pipes may be supplied in other lengths where so agreed upon between the manufacturer and the purchaser.

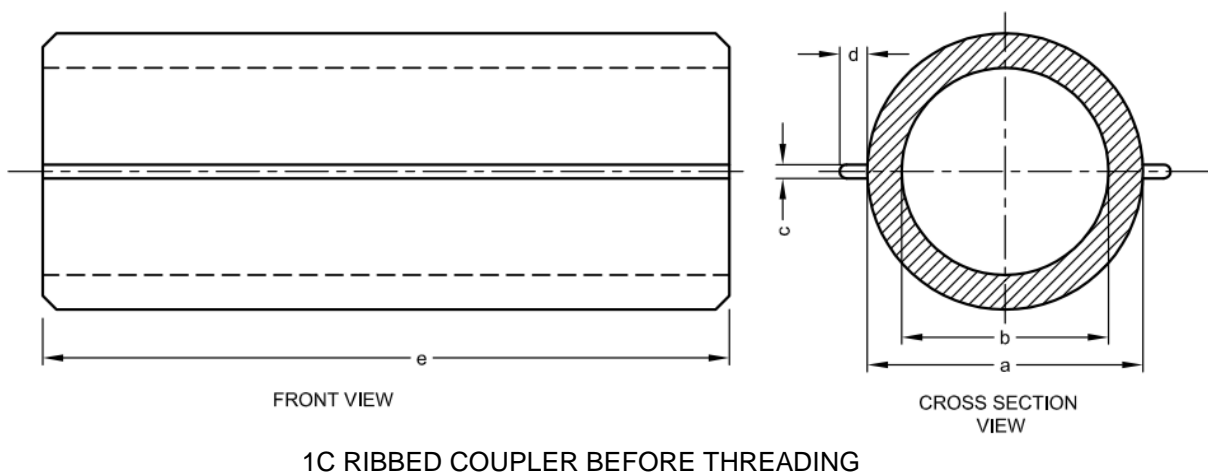
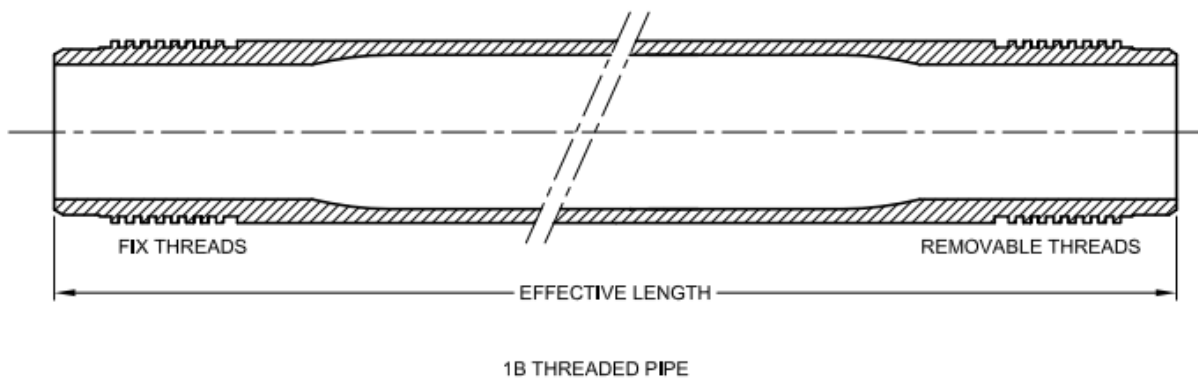
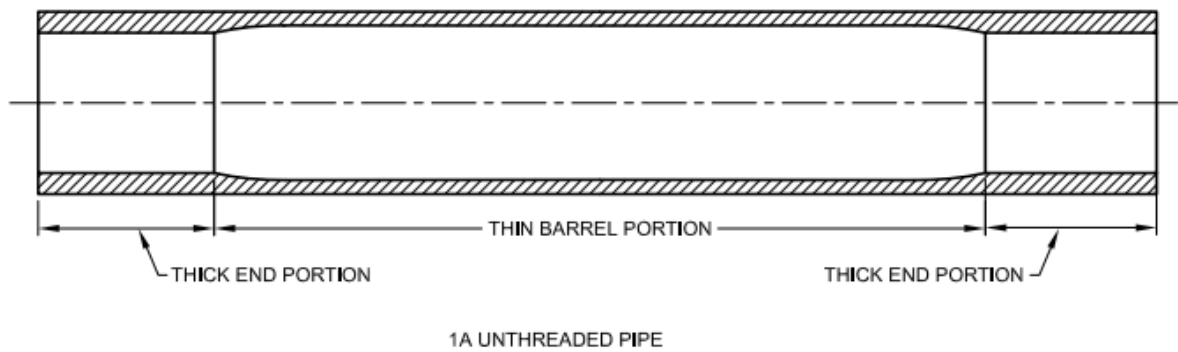

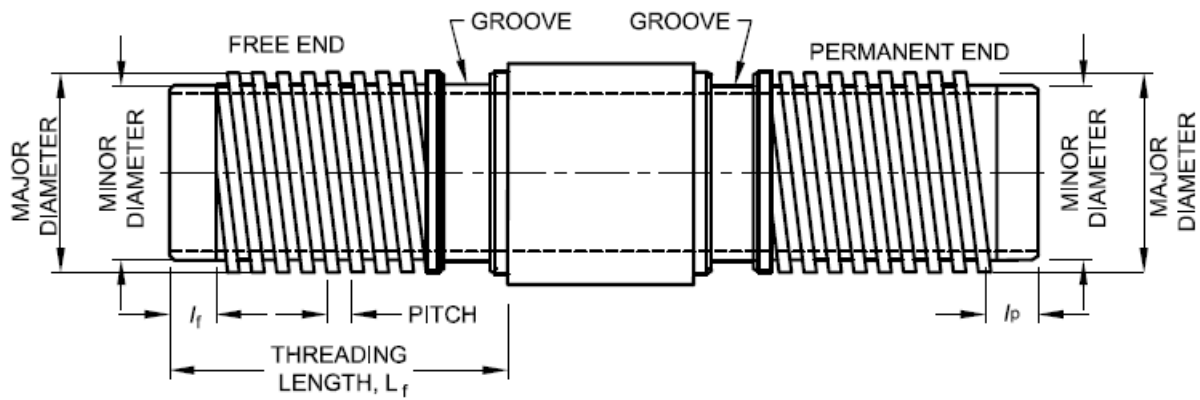

1D THREADS OF COLUMN PIPE

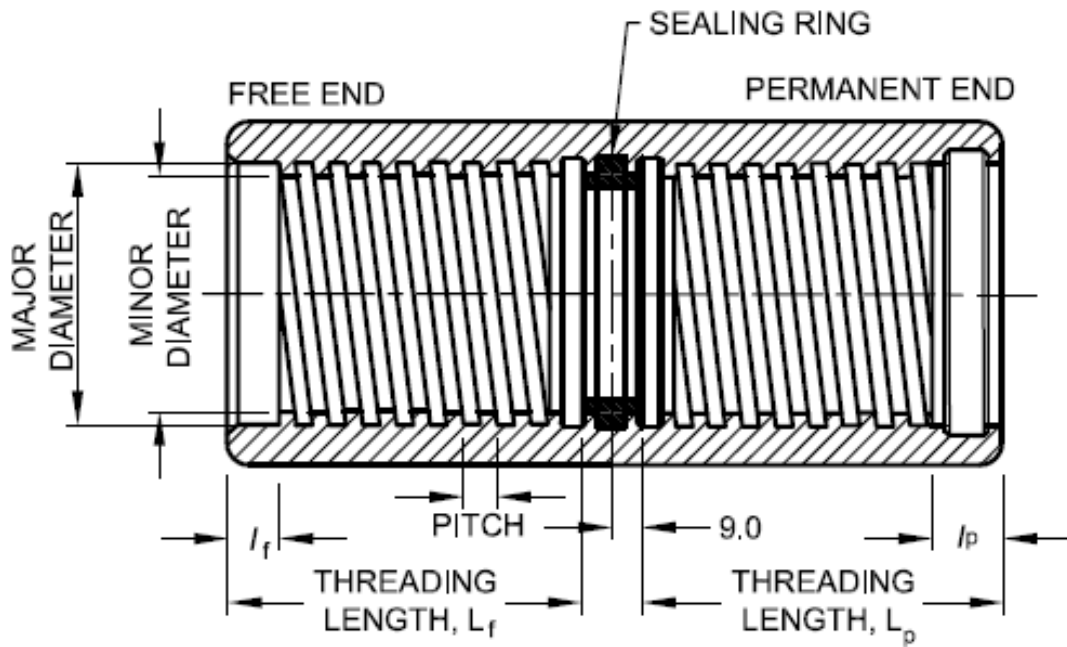

1E THREADS OF COLUMN PIPE COUPLERS

Fig. 1 COUPLER JOINTED THREADED COLUMN PIPES

Table 2 OUTER DIAMETER OF UNTHREADED COLUMN PIPES
(Clause 7.1.1)

All dimensions in millimetres.

SI No.	Nominal Size <i>DN</i>	Mean Outer Diameter of Pipe, d_{em}		Outer Diameter at Any Point, d_e	
		<i>Min</i>	<i>Max</i>	<i>Min</i>	<i>Max</i>
(1)	(2)	(3)	(4)	(5)	(6)
i)	25	33.0	33.6	33.1	33.8
ii)	32	42.0	42.3	41.8	42.5
iii)	40	48.0	48.3	47.8	48.5
iv)	50	60.0	60.3	59.8	60.5
v)	65	75.0	75.3	74.8	75.6
vi)	80	88.0	88.4	87.8	88.6
vii)	100	113.0	113.4	112.8	113.6
viii)	125	140.0	140.4	139.8	140.6
ix)	150	165.0	165.4	164.8	165.6

TABLE 3 WALL THICKNESS OF DIFFERENT CLASSES OF UNTHREADED COLUMN PIPES WITH THICK-THIN PORTION
(Clause 7.1.1)

SI No.	Nominal Size DN	Class of Pipe	Both End (Thick) Portion		Barrel (Thin) Portion		Length of Thick Portion at Both Side (L1 and L3), Min	Induced Stress, Min
			Min	Max	Min	Max		
(1)	mm (2)	mm (3)	mm (4)	mm (5)	mm (6)	mm (7)	mm (8)	MPa (9)
i)	25	Class 1	2.90	3.30	1.30	1.50	130	12
		Class 2	3.30	3.80	1.60	1.90	130	12
		Class 3	3.80	4.40	1.80	2.10	130	13
		Class 4	4.60	5.30	2.30	2.70	130	13
ii)	32	Class 1	3.30	3.80	1.50	1.80	180	14
		Class 2	3.70	4.30	1.80	2.10	180	14
		Class 3	4.30	5.00	2.20	2.50	180	14
		Class 4	5.40	6.20	2.80	3.20	180	14
		Class 5	6.50	7.50	3.50	4.00	180	14
		Class 6	8.30	9.60	4.70	5.40	160	14
iii)	40	Class 1	3.50	4.00	1.70	2.00	180	14
		Class 2	4.10	4.70	2.10	2.40	180	14
		Class 3	4.90	5.70	2.50	2.90	180	14
		Class 4	5.90	6.80	3.20	3.70	180	14
		Class 5	7.20	8.30	4.00	4.60	180	14
		Class 6	9.30	10.70	5.40	6.20	160	14
iv)	50	Class 1	4.20	4.90	2.10	2.40	180	14
		Class 2	4.90	5.60	2.60	3.00	180	14
		Class 3	5.90	6.80	3.10	3.60	180	14
		Class 4	7.20	8.30	4.00	4.60	180	14
		Class 5	8.80	10.10	5.00	5.80	180	14
		Class 6	11.10	12.80	6.70	7.70	160	14

v)	65	Class 1	5.00	5.80	2.60	3.00	180	14
		Class 2	6.00	6.90	3.30	3.80	180	14
		Class 3	7.00	8.10	3.90	4.50	180	14
		Class 4	8.60	9.90	5.00	5.80	180	14
		Class 5	10.40	12.00	6.20	7.10	180	14
		Class 6	13.50	15.50	8.40	9.70	160	14
vi)	80	Class 1	5.60	6.40	3.10	3.60	180	14
		Class 2	6.50	7.50	3.80	4.40	180	14
		Class 3	7.90	9.10	4.50	5.20	180	14
		Class 4	9.70	11.20	5.90	6.80	180	14
		Class 5	11.60	13.30	7.30	8.40	180	14
		Class 6	15.20	17.50	9.80	11.30	160	14
vii)	100	Class 1	6.80	7.80	3.90	4.50	180	14
		Class 2	8.20	9.40	4.90	5.70	180	14
		Class 3	9.60	11.00	5.80	6.70	180	14
		Class 4	11.90	13.70	7.50	8.60	180	14
		Class 5	14.30	16.50	9.30	10.70	180	14
		Class 6	19.00	21.90	12.60	14.50	160	14
viii)	125	Class 1	8.20	9.40	4.90	5.60	230	14
		Class 2	9.70	11.20	6.00	6.90	230	14
		Class 3	11.50	13.20	7.20	8.30	230	14
		Class 4	14.40	16.60	9.40	10.80	230	14
		Class 5	17.30	19.90	11.50	13.20	230	14
		Class 6	23.00	26.50	15.60	18.00	210	14
ix)	150	Class 1	9.30	10.70	5.70	6.60	230	14
		Class 2	11.20	12.90	7.10	8.20	230	14
		Class 3	13.10	15.10	8.40	9.70	230	14
		Class 4	16.60	19.10	11.00	12.70	250	14
		Class 5	20.10	23.10	13.60	15.70	230	14
		Class 6	26.90	31.00	18.40	21.20	210	14

NOTE – Length of thick portion ($L1$ and $L3$) at both ends of the pipe is required for thread operation for joining the pipes with each other with couplers.

TABLE 4 DIMENSIONAL DETAILS OF COLUMN PIPE COUPLERS
(Clause 7.1.1)

All dimensions in millimetres.

SI No.	Nominal Size DN	Mean Outer Diameter of Column Pipe Coupler, <i>Min</i>	Internal Diameter of Column Pipe Coupler, <i>Max</i>
(1)	(2)	(3)	(4)
i)	25	45.0	29.0
ii)	32	55.0	38.0
iii)	40	62.0	44.0
iv)	50	80.0	55.0
v)	65	92.0	70.0
vi)	80	108.0	83.0
vii)	100	139.6	108.0
viii)	125	168.0	134.0
ix)	150	200.0	159.0

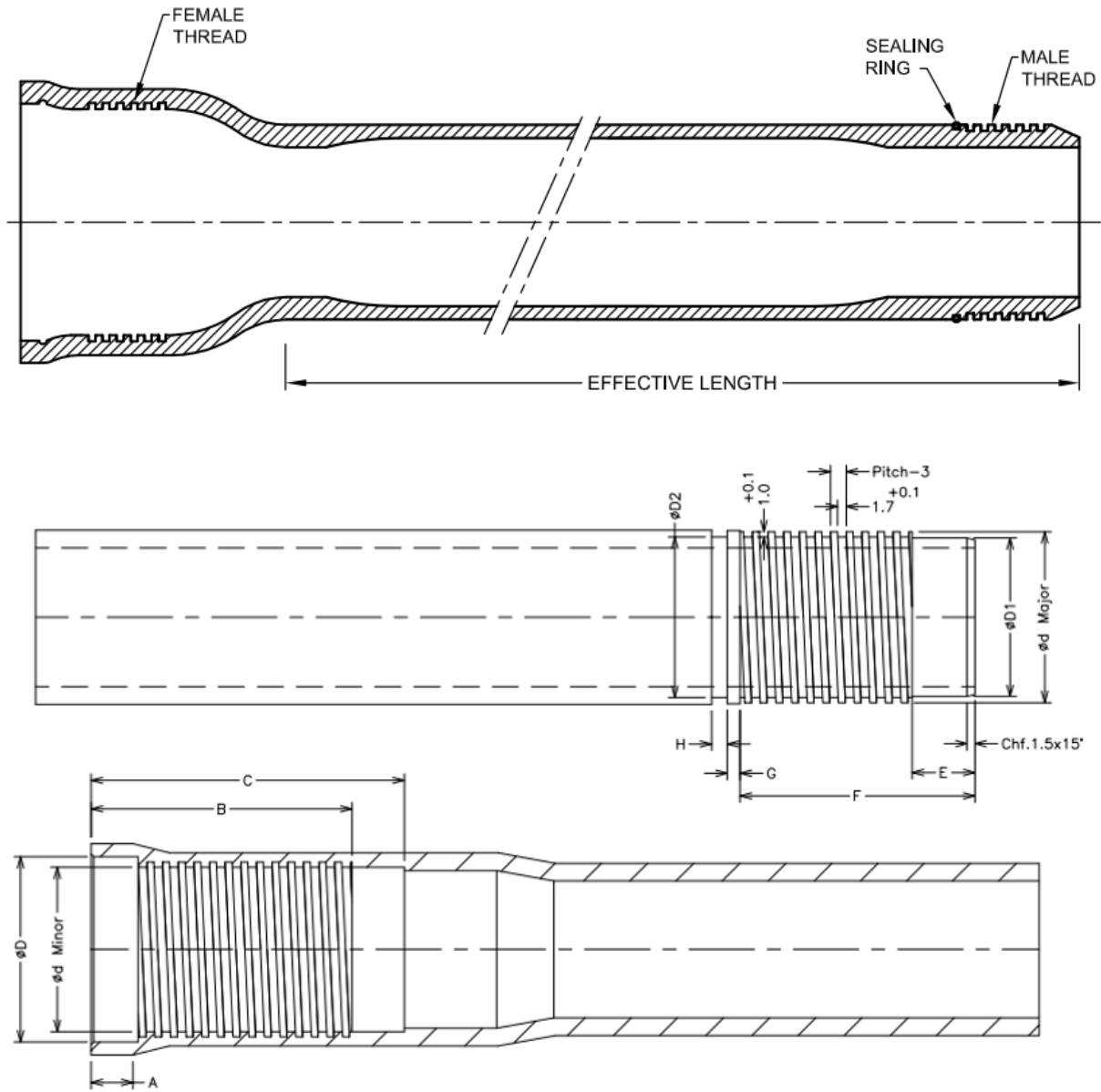

FIG. 2 BELL ENDED COLUMN PIPES WITH INTERNAL THREADS AT ONE END AND SPIGOT AT ANOTHER END WITH EXTERNAL THREADS

Table 5 Dimensions of Bell-Ended Pipes

(Clause 7.1.1)

All dimensions in millimetres.

SI No.	Nominal Size, <i>DN</i>	$D^{+0.2}_{-0.0}$	$D_1^{+0.0}_{-0.2}$	$D_2^{+0.0}_{-0.2}$	Major $d^{+0.0}_{-0.2}$	Minor $d^{+0.2}_{-0.0}$	$A^{+2.0}_{-0.0}$	$B^{+2.0}_{-0.0}$	$C^{+2.0}_{-0.0}$	$E^{+0.0}_{-0.2}$	$F^{+0.0}_{-0.2}$	$G^{+0.1}_{-0.0}$	$H^{+0.0}_{-0.2}$	Thread Depth	Pitch
(1)	(2)	(3)	(4)	(5)	(6)	(7)	(8)	(9)	(10)	(11)	(12)	(13)	(14)	(15)	(16)
i)	25	35.2	30.6	31.1	32.8	31.2	8	51	60	12	48	2.5	3.0	1.0	3.0
ii)	32	43.4	39.3	39.8	41.5	39.9	8	51	60	12	48	2.5	3.0	1.0	3.0
iii)	40	49.4	45.3	45.8	47.5	45.9	8	51	60	12	48	2.5	3.0	1.0	3.0

8 THREADING OF COLUMN PIPES AND COUPLERS

8.1 Column Pipes

Pipes with external threads at both ends shall be used with couplers. Bell end pipes shall have external threads at one end and internal threads at the other end.

8.2 Column Couplers

Column couplers shall have internal threads at both ends.

8.3 Pipes shall have basic thread dimensions as given in Table 6 read with Fig. 1D. Couplers shall have basic thread dimensions as given in Table 7 read with Fig. 1E.

8.4 Sealing rings and elements made of elastomeric material such as EPDM, and of appropriate dimensions ensuring secure fit, shall be used to seal the joint. These sealing materials shall be of shore hardness 65 ± 5 .

Table 6 THREAD DIMENSIONS FOR BOTH MALE ENDS OF COLUMN PIPE
(Clause 8.3)

All dimensions in millimetres.

SI No.	Nominal Size, DN	Male End (Tolerance ^{+0.0} _{-0.3})		Free End Side Length, Max		Permanent End Side Length, Max		Pitch
		Major Diameter	Minor Diameter	L_f	f_t	L_p	l_p	
(1)	(2)	(3)	(4)	(5)	(6)	(7)	(8)	(9)
i)	25	32.80	30.80	56.0	3.0	60.0	12	3.0
ii)	32	41.50	39.50	56.0	3.0	60.0	12	3.0
iii)	40	47.50	45.50	56.0	3.0	60.0	12	3.0
iv)	50	59.50	56.50	64.0	3.5	80.0	12	4.0
v)	65	74.50	71.50	64.0	3.5	80.0	12	4.0
vi)	80	87.50	84.30	64.0	3.5	85.0	14	4.0
vii)	100	112.50	109.10	74.0	5.0	85.0	14	6.0
viii)	125	139.50	135.50	84.0	5.0	104.0	14	6.0
ix)	150	164.50	160.50	84.0	5.0	104.0	14	6.0

**Table 7 THREAD DIMENSIONS FOR BOTH FEMALE ENDS OF
COLUMN PIPE COUPLER**

(Clause 8.3)

All dimensions in millimetres.

SI No.	Nominal Size, DN	Female End (Tolerance $^{+0.3}_{-0.0}$)		Free End Side Length, <i>Min</i>		Permanent End Side Length, <i>Min</i>		Pitch
		Major Diameter	Minor Diameter	L_f	f_f	L_p	l_p	
(1)	(2)	(3)	(4)	(5)	(6)	(7)	(8)	(9)
i)	25	33.20	31.20	60.0	15	51.0	14	3.0
ii)	32	41.90	39.90	60.6	15	51.0	14	3.0
iii)	40	47.90	45.90	60.6	15	51.6	14	3.0
iv)	50	60.00	57.00	66.3	15	72.3	14	4.0
v)	65	75.00	72.00	66.3	15	72.3	14	4.0
vi)	80	88.20	85.00	66.3	15	77.3	14	4.0
vii)	100	113.30	109.90	76.8	15	77.8	14	6.0
viii)	125	140.30	136.30	86.8	15	95.8	14	6.0
ix)	150	165.30	161.30	86.8	15	95.8	14	6.0

9 TESTS

9.1 Visual Appearance

The internal and external surfaces of the pipe shall be smooth, clean and free from other defects. Slight shallow longitudinal grooves or irregularities in the wall thickness shall be permissible provided the pipe dimensions remain within permissible limits. The ends shall be clean, smoothly cut and reasonably square to the axis of the pipe.

9.2 Resistance to External Blows at 0 °C

When tested by the method described in IS 12235 (Part 9), the pipe shall have a true impact rate of not more than 10 percent. The total mass of the striker and height of free fall shall correspond to the values given in Table 8.

Table 8 Total Mass of Striker and Height of Free Fall for Resistance to External Blows Test
(Clause 9.2)

SI No.	Nominal Size <i>DN</i>	Total Mass of Striker kg	Height of Free Fall mm	Number of Equidistant Lines to be Drawn (Nos.)
(1)	(2)	(3)	(4)	(5)
i)	25	0.25 ± 0.5 %	1 000 ± 10	1
ii)	32	0.25 ± 0.5 %	1 000 ± 10	1
iii)	40	0.25 ± 0.5 %	1 000 ± 10	3
iv)	50	0.25 ± 0.5 %	2 000 ± 10	3
v)	65	0.25 ± 0.5 %	2 000 ± 10	4
vi)	80	0.50 ± 0.5 %	2 000 ± 10	4
vii)	100	0.50 ± 0.5 %	2 000 ± 10	6
viii)	125	1.00 ± 0.5 %	2 000 ± 10	8
ix)	150	1.00 ± 0.5 %	2 000 ± 10	8

9.3 Flattening Test

When tested on the barrel portion of the pipe by the method described in IS 12235 (Part 19), the pipe sample shall not have any evidence of splitting, cracking or breaking.

9.4 Tensile Strength and Elongation at Break

When tested by the method described in IS 12235 (Part 13), the average tensile strength of two test specimens cut longitudinally from the same pipe at maximum load shall be not less than 45 MPa and the elongation at break shall not be less than 30 percent.

NOTE — The specimen for the test shall be prepared from a section of the pipe. The specimens shall be cut or machined from lengths of pipe in the longitudinal direction, that is, along the pipe axis.

9.5 Ultimate Breaking load

Ultimate breaking load shall be checked at both sides of the threaded assembly of column pipe or cut piece of thick end portion of pipe with coupler. Threaded assembly shall be fitted in suitable end fixtures. End fixtures shall then be mounted on the universal testing machine (UTM) of adequate capacity. The test temperature and test speed shall be (27 ± 2) °C and 10 mm/min, respectively. The jaws of the UTM shall be pulled until the assembly breaks. The pick load shall be noted. Minimum pick load shall be as per Table 9 for all size and class of pipes.

NOTE — A typical ultimate breaking load assembly is shown in Fig. 5 for reference.

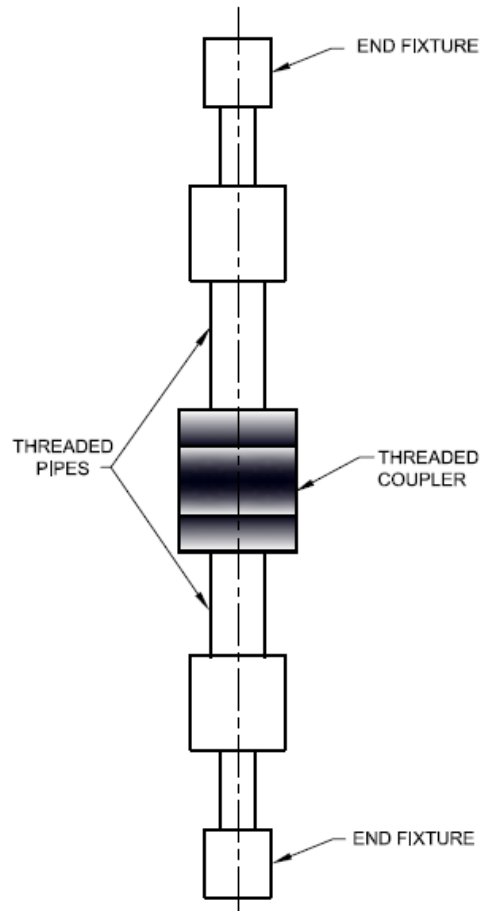

FIG. 5 TYPICAL ULTIMATE BREAKING LOAD ASSEMBLY

TABLE 9 ULTIMATE BREAKING LOAD
(Clause 9.5)

Sl No.	Nominal Diameter <i>DN</i>	Class of Pipe	Ultimate Breaking Load, <i>Min</i> kg
(1)	(2)	(3)	(4)
i)	25	Class 1	680
		Class 2	805
		Class 3	947
		Class 4	1 085
		Class 5	1 311
		Class 6	1 737
ii)	32	Class 1	1 157
		Class 2	1 282
		Class 3	1 403
		Class 4	1 758
		Class 5	2 131
		Class 6	2 808
iii)	40	Class 1	1 361
		Class 2	1 544

		Class 3	1 822
		Class 4	2 297
		Class 5	2 787
		Class 6	3 655
iv)	50	Class 1	1 837
		Class 2	2 391
		Class 3	2 826
		Class 4	3 588
		Class 5	4 405
		Class 6	5 721
v)	65	Class 1	3 241
		Class 2	3 681
		Class 3	4 388
		Class 4	5 607
		Class 5	6 833
		Class 6	8 915
vi)	80	Class 1	4 238
		Class 2	5 061
		Class 3	6 146
		Class 4	7 760
		Class 5	9 437
		Class 6	12 276
vii)	100	Class 1	6 579
		Class 2	8 402
		Class 3	9 879
		Class 4	12 754
		Class 5	15 449
		Class 6	20 265
viii)	125	Class 1	9 800
		Class 2	12 879
		Class 3	15 116
		Class 4	19 569
		Class 5	23 672
		Class 6	31 087
ix)	150	Class 1	13 347
		Class 2	17 959
		Class 3	21 072
		Class 4	27 136
		Class 5	32 763
		Class 6	43 211

9.6 Izod Impact Strength Test

When tested in accordance with the method described in Annex A, the notch Izod-impact strength shall not be less than 60 J/m.

9.7 Resistance to Dichloromethane Test

When tested in accordance with the method described in IS 12235 (Part 11), there shall be no attack observed on any part of the surface of test piece.

9.8 Density

When tested by the method described in IS 12235 (Part 14), the density of the material of the pipe shall be between 1.40 g/cm³ and 1.44 g/cm³.

9.9 Vicat Softening Temperature

The Vicat softening temperature shall not be less than 80 °C when tested by the method described in IS 12235 (Part 2).

NOTE — The test may be done on a test piece cut from a sample of the pipe used for some other test (such as density or resistance to external blows) as long as that sample has not been subjected to conditions that could influence the Vicat softening temperature. The specimen shall be supported on a suitable concave surface of radius equal to that of the sample pipe, ensuring support on all ends.

9.10 Effect on Water

The pipes shall not have any detrimental effect on the composition of water flowing through them. When tested in accordance with the method described in IS 12235 (Part 4) and IS 12235 (Part 10), the quantities of lead, dialkyl tin C4 and higher homologues (measured as tin) and any other toxic substances extracted from the internal walls of the pipes shall not exceed the concentrations as specified in **10.3** of IS 4985 and meet the other requirements given in **10.3.1** of IS 4985.

NOTE — Implementation of the phase-out programme of the Government of India for use of lead stabilizers in PVC pipe and fitting manufacturing shall be borne in mind.

9.11 Hydrostatic Pressure Test

When subjected to internal hydrostatic pressure test in accordance with the procedure given in IS 12235 (Part 8/Sec 1), the pipe shall not fail during the prescribed test duration. The temperature and duration of the test shall conform to the requirement given in Table 10. The test shall be carried out not earlier than 24 h after the pipes have been manufactured. This test should be performed on thin barrel portion.

Table 10 Requirement for Internal Hydrostatic Pressure Test
(Clause 9.11)

SI No.	Test	Test Temperature, <i>Min</i>	Test Duration (Minimum Holding Time)	Test Pressure, <i>Min</i>
		°C	h	MPa
(1)	(2)	(3)	(4)	(5)
i)	Acceptance Test	27	1	2.5 X PN

9.12 Joint Leak Pressure Test

When subjected to internal hydrostatic pressure test in accordance with the procedure given in Annex B, the representative assembly of pipe and coupler or bell end side and temporary thread of pipe side sample shall withstand for 1 hour without rupture, separation or leakage an internal hydrostatic pressure of 1.5 times the working pressure (PN) at room temperature.

10 SAMPLING AND CRITERIA FOR CONFORMITY

10.1 Acceptance Tests

10.1.1 The scale of sampling and criteria for conformity of a lot for acceptance tests specified in **7, 8, 9.1 to 9.5, 9.7 to 9.8, 9.11 and 9.12** shall be as given in Table 10.

10.1.2 All pipes, in a single consignment, of the same type, same size and same class, manufactured under essentially similar conditions, shall constitute a lot.

10.1.3 For ascertaining conformity of the lot to the requirements of the specification, samples shall be tested from each lot separately.

10.1.4 The pipes shall be selected at random from the lots in order to ensure randomness of selection, a random number table shall be used. For guidance on the use of random number tables, IS 4905 may be referred to. In the absence of a random number table, the following procedure may be adopted:

Starting from any pipe in the lot, count them as 1, 2, 3, etc, up to r and so on; where r is the integral part of N/n , N being the number of pipes in the lot and n the number of pipes in the sample. Every ' r th' pipe so counted shall be withdrawn so as to constitute the required sample size.

10.1.5 The number of samples given for the first sample of col 5 of Table 10 shall be taken from the lot and examined for requirements given in **7, 8 and 9.1**. A pipe failing to satisfy any of these requirements shall be considered as defective. The lot shall be deemed to have satisfied the requirements if the number of defectives found in the first sample is less than or equal to the corresponding acceptance number given in col 7. The lot shall be deemed not to have met these requirements, if the number of defectives found in the first sample is greater than or equal to the corresponding rejection number given in col 8. If, however, the number of defectives found in the first sample lies between the corresponding acceptance and rejection numbers given in col 7 and 8, a second sample of the size given in col 5 shall be taken and examined for these requirements. The lot shall be considered to have satisfied these requirements if the number of defectives found in the cumulative sample is less than or equal to the corresponding acceptance number given in col 7, otherwise not.

10.1.6 The lot, having satisfied the requirements under **10.1.5** shall be tested for the requirements in **9.2 and 9.3**. For this purpose, a sub-sample from those tested under **10.1.5** shall be drawn as given in col 10 of Table 10 for the first/second sample size. The lot shall be deemed to have met the requirements given in the standard, if the

number of defectives found in the first sample is less than or equal to the corresponding acceptance number given in col 12. The lot shall be deemed not to have met these requirements, if the number of defectives found in the first sample is greater than or equal to the corresponding rejection number given in col 13. If, however, the number of defectives found in the first sample lies between the corresponding acceptance and rejection numbers given in col 12 and 13, a second sample of the size given in col 9 shall be taken and tested for the requirement, the lot shall be deemed to have satisfied the requirements, if the number of defectives found in the cumulative sample is less than or equal to the corresponding acceptance number given in col 12, otherwise not.

10.1.7 The lot, having satisfied the requirements under **10.1.5** and **10.1.6**, shall be tested for **9.4, 9.5, 9.7, 9.8, 9.11** and **9.12**. For this, a sub-sample of 3 pipes from each lot irrespective of the lot size shall be selected from those tested under **10.1.5** and **10.1.6**. All pipes in the sub-sample shall be tested for requirements as specified in **9.4, 9.5, 9.7, 9.8, 9.11** and **9.12**. The lot shall be considered to have passed only if no failure is reported.

Table 10 Sampling and Acceptance Criteria
(Clauses 10.1.1, 10.1.5 and 10.1.6)

SI No.	Number of Pipes in the Lot	Nominal Size DN mm	For Tests under 7, 8 and 9.1					For Tests under 9.2 to 9.9				
			Sample		Cumulative Sample Size	Acceptance Number	Rejection Number	Sub-Sample		Cumulative Sample Size	Acceptance Number	Rejection Number
			No.	Size				No.	Size			
(1)	(2)	(3)	(4)	(5)	(6)	(7)	(8)	(9)	(10)	(11)	(12)	(13)
i)	Up to 1 000	≤ 100	1st	13	13	0	2	1st	3	3	0	2
			2nd	13	26	1	2	2nd	3	6	1	2
		> 100	1st	5	5	0	2	1st	3	3	0	1
			2nd	5	10	1	2	2nd	3	6	1	2
ii)	1 001-3 000	≤ 100	1st	20	20	0	3	1st	3	3	0	1
			2nd	20	40	3	4	2nd	3	6	1	2
		> 100	1st	8	8	0	2	1st	3	3	0	1
			2nd	8	16	1	2	2nd	3	6	1	2
iii)	3 001-10 000	≤ 100	1st	32	32	0	3	1st	3	3	0	1
			2nd	32	64	3	4	2nd	3	6	1	2
		> 100	1st	13	13	0	3	1st	3	3	0	1
			2nd	13	26	3	4	2nd	3	6	1	2
iv)	10 001 and above	≤ 100	1st	50	50	2	5	1st	6	6	0	1
			2nd	50	100	6	7	2nd	6	12	2	3
		> 100	1st	20	20	1	4	1st	4	4	0	1
			2nd	20	40	4	5	2nd	4	8	1	2

NOTE – For test under **9.2** the numbers mentioned in col 10 to col 13 represent the number of times the test is to be carried out. They do not represent the number of pipe samples nor the number of blows nor the number of failures.

10.2 Type Tests

These tests are intended to prove the suitability and performance of pipes whenever there is a change in the composition, size and type of pipe as well as in the method/technique in the manufacturing process. Test specified in **9.10** shall be taken as type test.

10.2.1 Izod Impact Strength Test

10.2.1.1 For this type test, the manufacturer or the supplier shall furnish to the testing authority three samples of pipes of different diameters and different classes of the same type (selected preferably from a regular production lot).

10.2.1.2 Three samples so selected shall be tested for compliance with the requirements of type test as given in **9.6**.

10.2.1.3 If all the three samples pass the requirements of the Izod impact strength test, the type test of the pipe under consideration shall be considered to be eligible for approval, which shall be normally valid for a period of one year.

10.2.1.4 In case any of the samples fails in this test, the testing authority, at its discretion, may call for fresh samples not exceeding the original number, and subject them to the test for Izod impact strength test. If, in the repeat test, no single failure occurs, the type of pipe under consideration shall be considered eligible for type approval. If any of the samples fails in the repeat test, the type of pipe shall not be approved. The manufacturer or the supplier may be asked to improve the design and resubmit the product for type approval.

10.2.1.5 At the end of the validity period (normally one year) or earlier, if necessary, the testing authority may call for fresh samples for Izod impact strength test for the purpose of type approval.

10.2.2 Vicat Softening Temperature Test

10.2.2.1 For this type test, the manufacturer or the supplier shall furnish to the testing authority three samples of pipes of different diameters and different classes of the same type (selected preferably from a regular production lot).

10.2.2.2 Three samples so selected shall be tested for compliance with the requirements for effect on water as given in **9.9**.

10.2.2.3 If all three samples pass the requirements for Vicat softening temperature test, the type test of the pipe under consideration shall be considered to be eligible for approval, which shall be normally valid for a period of one year.

10.2.2.4 In case any of the samples fails in this test, the testing authority, at its discretion, may call for fresh samples not exceeding the original number, and subject them to the test for Vicat softening temperature test. If, in the repeat test, no single failure occurs, the type of pipe under consideration shall be considered eligible for type approval. If any of the samples fails in the repeat test, the type of pipe shall not be

approved. The manufacturer or the supplier may be asked to improve the design and resubmit the product for type approval.

10.2.2.5 At the end of the validity period (normally one year) or earlier, if necessary, the testing authority may call for fresh samples for Vicat softening temperature test for the purpose of type approval.

10.2.3 Test for Effect on Water

10.2.3.1 For this type test, the manufacturer or the supplier shall furnish to the testing authority three samples of the smallest size of pipe taken from each machine (selected preferably from a regular production lot).

10.2.3.2 Three samples so selected shall be tested for compliance with the requirements for effect on water as given in **9.10**.

10.2.3.3 If all three samples pass the requirements for effect on water, the type test of the pipe under consideration shall be considered to be eligible for approval, which shall be normally valid for a period of one year.

10.2.3.4 In case any of the samples fails in this test, the testing authority, at its discretion, may call for fresh samples not exceeding the original number, and subject them to the test for effect on water. If, in the repeat test, no single failure occurs, the type of pipe under consideration shall be considered eligible for type approval. If any of the samples fails in the repeat test, the type of pipe shall not be approved. The manufacturer or the supplier may be asked to improve the design and resubmit the product for type approval.

10.2.3.5 At the end of the validity period (normally one year) or earlier, if necessary, the testing authority may call for fresh samples for effect on water test for the purpose of type approval.

11 MARKING

11.1 Each pipe shall be clearly and indelibly marked in ink/paint at intervals of not more than 1 metre, and strip in colour as indicated in **11.2**. The markings shall show the following:

- a) Manufacturer's name or trade-mark;
- b) Nominal size (*DN*);
- c) Class of pipe and working pressure rating;
- d) The phrase 'Column Pipe'; and
- e) Lot number/Batch number containing information of date of manufacture.

11.1.1 The lot number/batch number shall include the details of production in the following manner:

Year	Month	Day	Machine No.	Shift
XXXX	XX	XX	XXX	X

11.2 The information according to **11.1** and **11.1.1** shall be marked in black colour and a strip of minimum 3 mm width of colour as indicated below for different classes of pipes shall be provided. Alternatively, the information to be marked/painted can be printed in colour as given below without any strip.

<i>Sl No.</i>	<i>Class</i>	<i>Colour of Marking/Strip</i>
(1)	(2)	(5)
i)	Class 1	Red
ii)	Class 2	Blue
iii)	Class 3	Green
iv)	Class 4	Brown
v)	Class 5	Yellow
vi)	Class 6	Black

11.3 BIS Certification Marking

Each column pipe and coupler conforming to the requirements of this standard may be certified as per the conformity assessment schemes under the provisions of the *Bureau of Indian Standards Act, 2016* and the Rules and Regulations framed thereunder, and the pipe may be marked with the Standard Mark.

ANNEX A
(Clause 9.6)

METHOD OF TEST FOR DETERMINATION OF IZOD IMPACT STRENGTH

A-1 GENERAL

Izod impact strength is the striking energy absorbed by a notched test specimen relative to the cross-sectional area. This test is used to assess toughness or brittleness of the test specimen.

A-2 APPARATUS

Apparatus required for the test are,
a) V-Notch cutting Machine; and
b) Impact testing machine.

A-3 TEST SPECIMEN

A-3.1 Shape and Size

Test specimen shall be as per the following dimensions:

Length	:	61.9 ± 1.60 mm
Width	:	12.7 ± 0.15 mm
Thickness	:	Actual thickness
Notch	:	V notch at a distance of 31.75 ± 0.25 mm from one end. It should be perpendicular to the machine direction. Depth of the notch should be 2.54 ± 0.05 mm and angle 45° ± 1°.

A-3.2 Preparation

The specimen after cutting and grinding to the specified size as above shall be subjected to conditioning at temperature of 23 ± 2 °C and 50 ± 5 percent relative humidity in the Environmental Test Chamber for a minimum of duration of 30 min. Five test specimens shall be prepared for the test.

A-4 PROCEDURE

A-4.1 The test piece is mounted on the pendulum impact testing machine and the hammer is released to strike on the opposite side of the notch of the test specimen. Striking energy absorbed by the test specimen in joule is indicated on the scale of the impact testing machine.

A-4.2 The test piece shall be kept in vertical position while testing the impact and before striking the specimen, the dissipation energy shall be noted by releasing the hammer without test specimen. This dissipation energy shall be subtracted from the energy absorbed by specimen during the test and the reading shall be noted as A₀ joule.

Impact strength of the specimen shall be calculated as,

$$d_n = \frac{A_0 \times 1000}{h} \text{ J/m}$$

Where, h = thickness of the specimen.

ANNEX B
(Clause 9.12)

JOINT LEAK PRESSURE TEST

B-1 Scope

B-1.1 This Annex specifies the method for joint leak pressure test for the assembly of threaded pipe and coupler and threaded bell end pipe socket and threaded spigot pipe.

B-2 Test Pieces

B-2.1 Typical Specimen of assembly is shown in Fig. 6.

B-2.2 For the assembly of coupler type column pipe, take 2 numbers of 300 mm long cut piece one side threaded and 1 number of threaded coupler. Assemble 2 numbers of pipe cut piece at both end of the coupler at respective side of permanent and temporary side. Sealing ring at pipe and coupler as per the standard design of manufacturer should be fit as for practical use.

B-2.3 For the assembly of bell type pipe, take 1 number of 300 mm long pipe having threaded bell end at one side and other side plain. Take 1 number of 300 mm long pipe having temporary side thread at one side and other side plain. Assemble threaded end pipe into the bell end socket. Sealing ring at pipe should be provided as per the standard design of manufacturer.

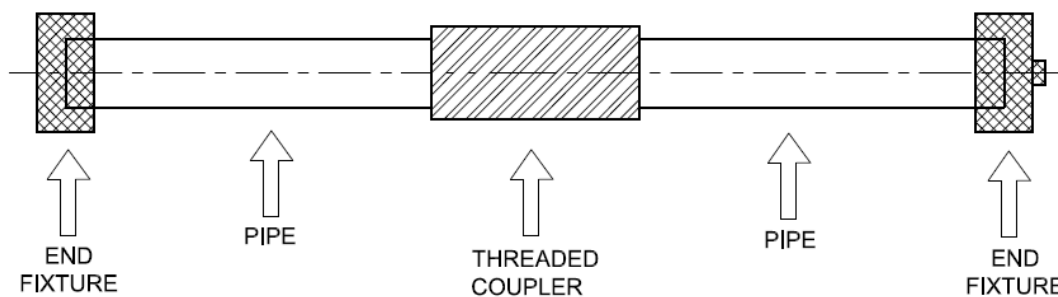

Fig. 6 Typical Assembly for Joint Leak Pressure Test

B-3 Test Method

After assembly, close both end of the pipe with suitable metal end caps. Fill the water into the assembly. This test should be performed at the floor and all precautions shall be taken for ensuring human safety. Attach assembly with hydrostatic pressure testing machine. Apply the hydrostatic pressure of 1.5 times the pressure rating (PN) for a period of 1 h. During the testing, monitor for any leakage from the coupler and pipe junction or pipe and bell end junction.