



भारतीय मानक ब्यूरो BUREAU OF INDIAN STANDARDS

MANAK BHAVAN, 9 BAHADUR SHAH ZAFAR MARG, NEW DELHI 110002

Phone: + 91 11 23230131, 23233375, 23239402 Extn 8406, 23608406; Website: www.bis.gov.in

व्यापक परिचालन मसौदा

हमारा संदर्भ: सीईडी 50/टी-93

10 जनवरी 2020

तकनीकी समिति : प्लास्टिक पाइपिंग सिस्टम विषय समिति, सीईडी 50

प्राप्तकर्ता :

- 1 सिविल इंजीनियरी विभाग परिषद के सभी सदस्य
- 2 प्लास्टिक पाइपिंग सिस्टम विषय समिति, सीईडी 50, पोलीओलीफिंस एवं जीआरपी पाइपिंग सिस्टम उपसमिति सीईडी 50:1, पीवीसी एवं एबीएस पाइपिंग सिस्टम उपसमिति, सीईडी 50:2, एवं PE-AL-PE पाइपिंग सिस्टम के लिए कार्य समूह के सभी सदस्य
- 3 रुचि रखने वाले अन्य निकाय।

महोदय/महोदया,

निम्नलिखित मसौदा संलग्न है:

प्रलेख संख्या	शीर्षक
सीईडी 50 (12111)WC	500 kPa (5 बार) तक के अधिकतम परिचालन दबाव वाले आंतरिक गैस संस्थापनों के लिए मल्टीलेयर (PE-AL-PE) प्लास्टिक पाइपिंग प्रणालियाँ — विशिष्ट का भारतीय मानक मसौदा (आई सी एस संख्या : 23.040.20; 23.040.45; 91.140.40)

कृपया इस मसौदे का अवलोकन करें और अपनी सम्मतियाँ यह बताते हुए भेजे कि यह मसौदा प्रकाशित हो तो इन पर अमल करने में, आपको व्यवसाय अथवा कारोबार में क्या कठिनाइयाँ आ सकती हैं।

सम्मतियाँ भेजने की अंतिम तिथि: 12 मार्च 2020

सम्मति यदि कोई हो तो कृपया अधोहस्ताक्षरी को ई मेल द्वारा madhurima@bis.gov.in पर या उपरलिखित पते पर, संलग्न फॉर्मेट में भेजें।

यदि कोई सम्मति प्राप्त नहीं होती है अथवा सम्मति में केवल भाषा संबंधी त्रुटि हुई तो उपरोक्त प्रलेख को यथावत अंतिम रूप दे दिया जाएगा। यदि सम्मति तकनीकी प्रकृति की हुई तो विषय समिति के अध्यक्ष के परामर्श से अथवा उनकी इच्छा पर आगे की कार्यवाही के लिए विषय समिति को भेजे जाने के बाद प्रलेख को अंतिम रूप दे दिया जाएगा।

यह प्रलेख भारतीय मानक ब्यूरो की वेबसाइट www.bis.gov.in पर भी उपलब्ध हैं।

धन्यवाद।

भवदीय

ह0/-

(संजय पंत)

प्रमुख (सिविल इंजीनियरिंग)

संलग्न: उपरलिखित



भारतीय मानक ब्यूरो
BUREAU OF INDIAN STANDARDS

MANAK BHAVAN, 9 BAHADUR SHAH ZAFAR MARG, NEW DELHI 110002

Phone: + 91 11 23230131, 23233375, 23239402 Extn 8406, 23608406; Website: www.bis.gov.in

DRAFT IN
WIDE CIRCULATION

DOCUMENT DESPATCH ADVICE

Reference	Date
CED 50/T-93	10 January 2020

TECHNICAL COMMITTEE:

PLASTIC PIPING SYSTEMS SECTIONAL COMMITTEE, CED 50

ADDRESSED TO:

1. All Interested Members of Civil Engineering Division Council, CEDC
2. All Members of Plastic Piping System Sectional Committee, CED 50, Polyolefins and GRP Piping System Subcommittee, CED 50:1, PVC and ABS Piping System Subcommittee, CED 50:2 and Working Group for PE-AL-PE Piping System
3. All others interested

Dear Sir/Madam,

Please find enclosed the following draft:

Doc. No.	Title
CED 50 (12111)WC	Draft Indian Standard Multilayer (PE-Al-PE) Plastics Piping Systems for Indoor Gas Installations with a Maximum Operating Pressure up to and Including 500 kPa (5 Bar) — Specification (ICS No. 23.040.20; 23.040.45; 91.140.40)

Kindly examine the draft revision and forward your views stating any difficulties which you are likely to experience in your business or profession, if this is finally adopted as National Standards.

Last Date for comments: 12 March 2020

Comments if any, may please be made in the format as given overleaf and emailed at madhurima@bis.gov.in or sent at the above address.

In case no comments are received or comments received are of editorial nature, you will kindly permit us to presume your approval for the above document as finalized. However, in case comments, technical in nature are received, then it may be finalized either in consultation with the Chairman, Sectional Committee or referred to the Sectional Committee for further necessary action if so desired by the Chairman, Sectional Committee.

The document is also hosted on BIS website www.bis.gov.in.

Thanking you,

Yours faithfully,

Sd/-

(Sanjay Pant)
Head (Civil Engg.)

Encl: As above

DRAFT FOR COMMENTS ONLY

(Not to be reproduced without the permission of BIS or used as an Indian Standard)

Plastic Piping System
Sectional Committee, CED 50

Last date of Comments:
12 March 2020

Draft Indian Standard

**MULTILAYER (PE-AL-PE) PLASTICS PIPING SYSTEMS FOR INDOOR GAS
INSTALLATIONS WITH A MAXIMUM OPERATING PRESSURE
UP TO AND INCLUDING 500 KPA (5 BAR) — SPECIFICATION**

FORWARD

(Formal clauses to be added later)

This Indian Standard has been formulated to cover requirements for multilayer (PE-AL-PE) plastics piping systems for indoor gas installations with a maximum operating pressure up to and including 500 KPa (5 bar).

In the preparation of this standard, considerable assistance has been derived from ISO 17484-1:2014 'Plastics piping systems — Multilayer pipe systems for indoor gas installations with a maximum operating pressure up to and including 5 bar (500 kPa) — Part 1: Specifications for systems', which was developed in response to worldwide demand for a new specification for multilayer pipes for gas supply. In India also, due to our national focus to develop smart cities across the country, a large demand is expected to emerge for the installation of new gas networks of multilayer pipes for the transportation of domestic gas. The multilayer PE-AL-PE composite pipe is composed of one metallic layer, tie layers of polymeric adhesive and inner and outer layers of polyethylene. The inner and outer layers are bonded to metallic layer which is welded aluminium tube, by polymeric adhesive during extrusion process.

This standard covers the following categories of fuels to be transported as per ISO 13623:2017 'Petroleum and natural gas industries — Pipeline transportation systems':

- a) Category D – Gaseous fuels – Non-toxic, single phase natural gas; and
- b) Category E – Gaseous fuels – Flammable and/or toxic fluids that are gases at ambient temperature and atmospheric pressure conditions and are conveyed as gases and/or liquids, like liquefied petroleum gas (LPG) vapour and natural gas (not otherwise covered in category D) or liquefied petroleum gas.

The minimum value of service design co-efficient at 27 °C shall be considered as 2 for conveyance of gaseous fuels.

In this standard, for the evaluation of PE compound, an additional type test for 10 000 h at 20 °C has been included. For aluminium material to be used for the manufacture of multilayer pipes, aluminium grade 31200 as per IS 737:2008 'Wrought Aluminium and Aluminium Alloy Sheet and Strip for General Engineering Purposes – Specification (*fourth revision*)' which is equivalent to ENAW 3003 grade of EN 573-3 'Aluminium and aluminium alloys - Chemical composition and form of wrought products - Part 3: Chemical composition and form of products' as prescribed in ISO 17484-1:2014, has been specified.

Multilayer pipes are delivered generally as a complete system. Pipes, fittings, tools, etc are mostly not compatible with components of other brands/make. All components in a system are perfectly geared to one another when they are procured from the same manufacturer. Further, in case of repair/maintenance, the consumer can ensure to procure spares/accessories from the same source.

Connections of threaded transition fittings shall be as per IS 554:1999 'Pipe threads where pressure-tight joints are made on the threads — Dimensions, tolerances and designation (*fourth revision*) (Adoption of ISO 7-1:1994)'.

In the formulation of this standard assistance has also been derived from ASTM F 1282-17 'Standard specification for Polyethylene/Aluminum/Polyethylene (PE-AL-PE) composite pressure pipe'. Provisions of IS 14885:2001 'Specification for polyethylene pipes for the supply of gaseous fuels — Specification' have also been considered while preparing this standard.

This standard also provides guidelines for the storage, handling and installation of PE-AL-PE multilayer pipes and fittings in its Annex R.

This standard does not purport to address all the safety issues associated with the use of this piping system. It is the responsibility of the user of this standard to establish appropriate safety and health practices and determine the applicability of regulatory safety and health practices in accordance with the applicability of regulatory limitations prior to use.

For the purpose of deciding whether a particular requirement of the standard is complied with the final value observed or calculated, expressing the result of a test or analysis, shall be rounded off in accordance with IS 2:1960 'Rules for rounding off numerical values (*revised*)'. The number of significant places retained in the rounded off value should be the same as that of the specified value in this standard.

DRAFT FOR COMMENTS ONLY

(Not to be reproduced without the permission of BIS or used as an Indian Standard)

Plastic Piping System
Sectional Committee, CED 50

Last date of Comments:
12 March 2020

Draft Indian Standard

**MULTILAYER (PE-AL-PE) PLASTICS PIPING SYSTEMS FOR INDOOR GAS
INSTALLATIONS WITH A MAXIMUM OPERATING PRESSURE
UP TO AND INCLUDING 500 KPA (5 BAR) — SPECIFICATION**

1 SCOPE

1.1 This standard specifies the general requirements and the performance requirements for multilayer (PE-AL-PE) plastics piping systems based on pipes, fittings and their joints intended to be used for gas supply within buildings, ranging from 14 mm to 75 mm outside diameter. This standard applies to systems that operate at temperatures of $-20\text{ }^{\circ}\text{C}$ up to $+60\text{ }^{\circ}\text{C}$. For the purpose of this standard, adhesive layers are considered as thermoplastic materials. This standard is applicable for piping systems used in buildings to supply gas with a maximum operating pressure of up to and including 500 kPa (5 bar). This standard is applicable for the conveyance of following fuels:

- a) Non-toxic natural gas; and
- b) Flammable and/or toxic fluids which are gaseous at ambient temperature and atmospheric pressure conditions and are conveyed as gases and/or liquids.

1.2 This standard gives guidance for the design of piping systems consisting of multilayer pipes based on thermoplastics, for which at least 60 percent of the wall thickness shall be polymeric material. Polymeric materials intended for stress-designed layer (inner layer) shall be polyethylene (PE). The outer layer shall also be polyethylene (PE), and the intermediate layer shall be aluminium.

2 REFERENCES

The standards listed below contain provisions which through reference in this text, constitute provision of this standard. At the time of publication, the editions indicated were valid. All standards are subjected to revision and parties to agreements based on this standard are encouraged to investigate the possibility of applying most recent editions of the standards indicated below:

<i>IS No.</i>	<i>Title</i>
554:1999	Pipe threads where pressure-tight joints are made on the threads — Dimensions, tolerances and designation (<i>fourth revision</i>)
737 : 2008	wrought aluminium and aluminium alloy sheet and strip for general engineering purposes — Specification (<i>fourth revision</i>)
2530 : 1963	Methods of test for polyethylene moulding materials and polyethylene compounds
4905 : 2015	Random sampling and randomization procedures (<i>first revision</i>)
4984 : 2016	Polyethylene pipes for water supply — Specification (<i>fifth revision</i>)
7328 :1992	High density polyethylene materials for moulding and extrusion (<i>first revision</i>)
14885:2001	Polyethylene pipes for the supply of gaseous fuels — Specification
15450 : 2004	Polyethylene/Aluminium/Polyethylene composite pressure pipes for hot and cold water supplies — Specification
IS 16462:2016 /ISO 9080:2012	Plastic piping and ducting systems — Determination of the long-term hydrostatic strength of thermoplastics materials in pipe form by extrapolation

3 TERMINOLOGY

For the purposes of this standard the following definitions shall apply:

3.1 Structural Definitions

3.1.1. Multilayer Pipe – Pipe comprised of stress-designed inner polymeric layer and one stress-designed metallic layer. The wall thickness of the pipe consists of at least 60 percent of polymeric materials. For the purpose of this standard, the multilayer pipe is a three layer (PE-AL-PE) pipe with stress-designed layer (inner layer) and outer layer of polyethylene (PE), and the intermediate layer of aluminium.

3.1.2. Layer – Homogeneous circumferential section of pipe wall that has chemical and/or mechanical and/or physical characteristics different from those of its immediate neighbours.

3.1.3 Inner Layer – Layer in contact with conveyed fluid.

3.1.4 Outer Layer – Layer exposed to the external environment.

3.2 Geometric Definitions

3.2.1 Nominal Diameter (DN) – Specified diameter assigned to nominal size (DN/OD or DN/ID).

NOTE — The nominal diameter is expressed in units of millimetres.

3.2.2 Outside Diameter, d_e – Diameter measured through its cross-section at any point of a pipe or the fitting end of a fitting, rounded to next greater 0.1mm.

3.2.3 Mean Outside Diameter – Measured length of the outer circumference of the pipe divided by π (≈ 3.142), rounded to the nearest 0.1 mm.

3.2.4 Inside Diameter – Value of the measurement of the diameter, through its cross section at any point of a pipe, rounded to next greater 0.1 mm.

3.2.5 Metal Layer Standard Dimension Ratio (SDR_m) – The nominal outside diameter (DN or OD) divided by the nominal wall thickness of the metal layer.

3.2.6 Wall Thickness - Difference between the pipe outside diameter used for joining and the pipe bore divided by 2.

3.2.7 Nominal Wall Thickness, e_n – Wall thickness corresponding to the minimum wall thickness at any point.

NOTE — The nominal wall thickness is expressed in units of millimetres.

3.2.9 Mean Wall Thickness, e_m - Arithmetic mean of at least four measurements regularly spaced around the same cross sectional plane of the pipe, including the measured minimum and maximum value obtained, rounded up to the nearest 0.1 mm.

3.3 Definitions Related to Pressure

3.3.1 Design Pressure, P_D - Highest pressure related to the circumstances for which the system has been designed and intended to be used.

3.3.2 Predicted Design Pressure, P_{CD} - Pressure that represents the predicted design pressure after a lifetime of 50 years, using the 97.5 percent reference line.

NOTE — The predicted design pressure is expressed in units of Kilopascals (bars).

3.4 Definitions Related to Material

3.4.1 Virgin Material - Material in a form such as granules or powder that has not been subjected to use or processing other than that required for its manufacture and to which no reprocessible or recyclable material has been added.

3.4.2 Rework Material - Material prepared from rejected unused pipes and fittings, including trimmings from the production of pipes and fittings that can be reprocessed in a manufacturer's plant after having been previously processed by the same manufacturer by a process such as moulding or extrusion and for which the complete formulation is known.

3.4.3 Stress-Designed Layer - Plastics materials used for layers intended to be stress bearing, and which shall be restricted to the reference material standards.

3.5 Definitions Related to Material Characteristics

3.5.1 Long Term Hydrostatic Strength (Long Term Pressure Strength) – Quantity with the dimensions of stress, which represents the predicted mean strength at a temperature, T and a time, t .

NOTE — The long-term hydrostatic strength is expressed in units of mega pascals.

3.5.2 Lower Confidence Limit of the Predicted Hydrostatic Pressure P_{LPL} - Lower confidence limit of the predicted hydrostatic pressure, which represents the 97.5 percent (one-sided) lower confidence limit of the predicted hydrostatic pressure at a temperature, T and a time, t .

NOTE — The lower confidence limit of the predicted hydrostatic pressure is expressed in units of kilopascals (bars).

3.5.3 Minimum Required Pressure (MRP) - Minimum required pressure, equal to the estimated long-term pressure resistance of a pipe at temperature of 27 °C and a time of 50 years.

3.5.4 Design Coefficient Factor, C – Design coefficient with a value greater than 1, which takes into consideration service conditions as well as properties of the components of a piping system other than those represented in the lower confidence limit.

NOTE — The minimum value of C for the purpose of this standard is 2.

3.6 Terms Related to Service Conditions

3.6.1 Gaseous Fuel – Any fuel which is in gaseous state at a temperature of 15 °C and a pressure of 100 kPa (1 bar).

3.6.2 Category D Gaseous Fuel – Non-toxic Natural Gas

3.6.3 Category E Gaseous Fuel – Flammable and/or toxic fuels which are gaseous at ambient temperature and atmospheric pressure conditions and are conveyed as gases and/or liquids.

3.6.4 Maximum Operating Pressure, MOP – Maximum pressure at which a system can be operated continuously under normal conditions.

4 REQUIREMENTS FOR THE SYSTEM

4.1 Pressure Drop

The manufacturer shall provide information on the pressure drop in the system.

4.2 Bending

Special attention shall be paid to the pressure drop of bends. Bending properties of the pipe shall be stated by the manufacturer.

5 PIPES

5.1 Materials

5.1.1 Grades of Materials

The grade of PE material for the stress bearing layer (inner layer) and the outer layer shall be as per Table 1.

Table1 Classification of PE Materials
(Clause 5.1.1)

Sl. No.	Material	Minimum Required Strength (MRS) of Material at 20 °C for 50 years MPa	Maximum Allowable Hydrostatic Design Stress, σ at 20 °C MPa
(1)	(2)	(3)	(4)
i)	PE 80	8.0	4.0

5.1.2 Characteristics of PE Compound

Materials intended for the stress bearing layer (inner layer) and the outer layer shall PE 80 grade conforming to the requirements in 5 of IS 14885. The characteristics of the PE compound shall be as given in Table 2.

NOTES

- 1 Adhesives are not considered as stress bearing layers.
- 2 Only compounded material is permitted for the manufacture of these pipes. The compound supplier shall provide the pipe manufacturer with certified test results for PE compound classification as per Table 1 and its characteristics as per Table 2.

Table 2 Characteristics of PE Compound
(Clause 5.1.2)

Sl. No.	Characteristics	Units	Requirements	Test Parameter	Test Method
(1)	(2)	(3)	(4)	(5)	(6)
i)	Base Density	kg/m ³	≥ 930	23 °C	IS 7328
ii)	Melt Flow Rate	g/10 min	± 20 percent of value nominated by compound producer	190 °C/5 kg	IS 2530
iii)	Oxidation Induction Time	min	≥ 20	200 °C	Annex A
iv)	Anti-oxidant	By mass	< 0.3 percent	-	IS 2530

5.1.3 PE Compound Quality Evaluation

In order to establish the validity of classification for the material received by the manufacturer and to get qualified for the production of PE-AL-PE multilayer pipes for supply of gaseous fuel, an additional type approval test for long-term hydrostatic strength at 1 MPa, 20 °C for 10 000 h shall be conducted once on multilayer pipe with highest SDR_m of the metal layer.

5.1.4 Rework Material

No rework material shall be used in the manufacture of the pipes.

5.1.5 Metallic Material

The metallic material, that is, aluminium used for manufacture of PE-AL-PE pipes shall be Grade 31200 of IS 737 having minimum tensile strength of 95 MPa and minimum percentage elongation of 20 percent.

5.2 GENERAL CHARACTERISTICS

5.2.1 Visual Appearance

The internal surface of the pipe shall generally be smooth, clean and free from grooving, rings and poke marks which may effect the pipe performance. The ends shall be cleanly cut and shall be square with the axis of the pipes. Slight shallow longitudinal grooves or irregularities in the wall thickness shall be permissible provided that the wall thickness remains within the permissible limits.

5.2.2 Colour

Colour of the outer PE layer of the pipe shall be yellow.

5.2.3 Pigment Dispersion

The grading of pigment dispersion of outer PE layer when tested as per Annex B shall be ≤ 3 .

5.2.4 Multilayer Pipe Construction

The joint line of metallic layer shall be continuously welded.

5.2.4 Minimum Design Coefficient

The minimum design coefficient, C shall be 2.

5.3 PRESSURE RATING

The PE-AL-PE composite pipe meeting the requirements of this specification shall be pressure rated for maximum gas pressure of 500 kPa (5 bar).

5.5 DIMENSIONS OF PIPES

5.5.1 The dimensions of pipes shall be as per Table 3.

Table 3 Dimensions of Multilayer Pipe for Indoor Gas Installations
(Clause 5.5.1)

SI No.	Nominal Pipe Size	Minimum Outside Diameter	Tolerance on Minimum Outside Diameter	Maximum Out of Roundness	Total Wall Thickness		Minimum Wall Thickness of Inner layer	Minimum Wall Thickness of Aluminium Layer	Tolerance on Minimum Aluminium Thickness	Minimum Thickness of Outer Layer
					Min	Max				
(1)	(2)	mm	mm	mm	mm	mm	mm	mm	mm	mm
i)	14	14.00	+0.30	0.3	1.70	2.10	0.70	0.18	+0.03	0.4
ii)	16	16.00	+0.30	0.4	1.70	2.10	0.90	0.18	+0.03	0.4
iii)	20	20.00	+0.30	0.6	1.90	2.30	1.00	0.23	+0.03	0.4
iv)	25	25.00	+0.30	0.6	2.30	2.80	1.10	0.23	+0.03	0.4
v)	32	32.00	+0.40	0.8	2.90	3.50	1.20	0.28	+0.03	0.4
vi)	40	40.00	+0.40	1.0	3.90	4.50	1.70	0.33	+0.03	0.4
vii)	50	50.00	+0.50	1.3	4.40	5.00	1.70	0.47	+0.04	0.4
viii)	63	63.00	+0.50	1.4	5.80	6.40	2.10	0.57	+0.04	0.4
ix)	75	75.00	+0.60	1.5	7.30	7.90	2.80	0.67	+0.05	0.4

5.5.2 Method of Measurements

5.5.2.1 The thickness of the outer layer of polyethylene, when tested as per Annex C, in the PE-AL-PE pipe shall have a minimum value as specified in Table 3, except for polyethylene material overlaying the weld, which shall have a minimum thickness of half that specified in Table 3.

5.5.2.2 The outside diameter of pipe shall be taken as the average of two measurements taken at right angles. The wall thickness shall be measured by a dial/digital vernier or ball ended micrometer. The resulting dimension shall be expressed to the nearest 0.1 mm.

5.5.2.3 Ovality

Ovality (out of roundness) shall be measured as the difference between maximum outside diameter and minimum outside diameter measured at the same cross section of the pipe. For pipes to be coiled, the ovality shall be measured prior to coiling. For coiled pipes, however, re-rounding of pipes shall be carried out prior to the measurement of ovality.

5.5.3 Length of Straight Pipe

The pipe shall be supplied in straight lengths of 3 m or 6 m, or lengths as agreed between the manufacturer and the purchaser.

5.5.4 Coiling

While coiling, the inside diameter of coils shall not be less than 20 times the outside diameter of pipe.

5.6 MECHANICAL PROPERTIES

5.6.1 Internal Pressure Creep Rupture Test

When subjected to internal pressure creep rupture test in accordance with procedure given in Annex D, the pipes under test shall show no signs of localized swelling, leakage or weeping and shall not burst during the prescribed test period. The temperatures, duration of test and pressure for the test shall conform to those specified in Table 4.

Table 4 Internal Pressure Creep Rupture Test Parameters
(Clause 5.6.1)

SI No.	Nominal Pipe Size	Test Pressure at (27 ± 2) °C, for 1 h MPa	Test Pressure at (60 ± 2) °C, for 10 h MPa	Test Pressure at (95 ± 2) °C, for 170 h MPa
(1)	(2)	(3)	(4)	(5)
i)	14	3.0	2.5	1.3
ii)	16	3.0	2.5	1.2
iii)	20	2.8	2.5	1.0
iv)	25	2.8	2.5	1.0
v)	32	2.8	2.5	0.9
vi)	40	2.6	2.1	0.9
vii)	50	2.4	2.1	0.9
viii)	63	2.4	2.1	0.9
ix)	75	2.4	2.1	0.9

5.6.2 Strength of the Joint Line

The test shall be carried out in accordance with Annex E. When the outside diameter of the pipe is increased by 10 percent, no failures relative to the joint line of the metal layer shall occur.

5.6.3 Resistance to Slow Crack Growth of the Outer Layer (Cone Test)

The test shall be carried out on pipe produced from material used for the outer layer in accordance with Annex F. The crack growth rate shall be less than 10 mm/day.

5.7 PHYSICAL PROPERTIES

Pipes shall fulfill requirements for physical properties as given in Table 5.

Table 5 Physical Properties
(Clause 5.7)

SI No.	Characteristics	Requirements	Tests		Reference
			Parameters	Values	
i)	Resistance to gas constituents	≥ 20 h No delamination	Conditioning	1 500 h/ (23±2) °C	Annex G
			Temperature	80 °C	
			Cone Test	10 percent expansion	
		No delamination	Conditioning	1 500 h/ (23±2) °C	
			Temperature	(23±2) °C	
			Pressure	0.4 P _D	

SI No.	Characteristics	Requirements	Tests		
			Parameters	Values	Reference
ii)	Thermal Durability of Outer layer	No visual cracks in outer layer (PE)	At 100 °C or	0.5 year	Annex H
			At 110 °C	0.25 year	
			Strain	3 percent	
iii)	Delamination	Peel strength \geq 15 N/cm	Temperature	(23 \pm 2) °C	Annex J
			Cycling Test	(-20 \pm 2) °C/ (+60 \pm 2) °C	
			No. of Cycles	10	
iv)	Odorant Permeability	No perception of Tetrahydrothiophene (THT) or any other odorant (as permitted by the concerned statutory authority) smell by experienced observer	Odorant	THT	Annex K
			Exposure time	60 days	
			Temperature	(23 \pm 2) °C	

6 FITTINGS

6.1 General

6.1.1 Mechanical fittings shall be used. The pipes and fittings of the same make shall preferably be used. However, in case fitting of different make is to be used, then the fitting manufacturer shall establish compatibility of those fittings with pipes as an integrated system meeting the requirements of this standard, through tests as given in this standard.

6.1.2 Installation

During installation of the fitting on the pipe, the aluminium layer, and in particular the welded seam, shall not be torn.

Tools and aids used for installation of the fitting shall not damage the pipe and/or fitting.

6.2 Materials

The materials used in stress-designed fitting components shall be such that the level of performance of these components shall be at least equal to the performance of the multilayer pipe specified in relation to the application. The fitting shall be manufactured from De-Zincification (DZR) brass or brass conforming to IS 319, and shall not be casted.

6.3 Dimensions of Fittings

The mechanical fittings shall be manufactured with such dimensions and within such tolerances that the fittings for the corresponding pipe sizes shall meet the requirements of 7.2.

6.4 Transition Fittings

The manufacturer shall provide a transition fitting intended to be connected to a standardized system. The connection shall comply with the relevant standards, for example, IS 554.

6.5 Rubber Rings

Rubber rings used for the fittings shall be of nitrile rubber with Shore –A hardness 60-70.

7 FITNESS FOR PURPOSE

7.1 Diameter Classes

The diameter classes which are defined based on ranges of the external diameter shall be as per Table 6.

Table 6 Diameter Classes
(Clause 7.1)

SI No.	Characteristics	Diameter Class						
		1	2	3	4	5	6	7
(1)	(2)	(3)	(4)	(5)	(6)	(7)	(8)	(9)
i)	External diameter, in mm	$d_e < 16$	$16 \leq d_e < 20$	$20 \leq d_e < 26$	$26 \leq d_e < 40$	$40 \leq d_e < 50$	$50 \leq d_e < 60$	$60 \leq d_e \leq 75$
ii)	Nominal pipe size, in mm	14	16	20 and 25	32	40	50	63 and 75

7.2 Requirements

To avoid gas diffusion between the layers, the pipe shall be sealed in the joint at the inner-layer. Joint assemblies shall fulfill the requirements of Table 7 for the complete diameter range of the multilayer system.

Table 7 REQUIREMENT FOR FITNESS PURPOSE OF JOINT ASSEMBLIES
(Clause 7.2)

SI No.	Characteristic	Requirements	Tests		
			Parameter	Value	Reference
(1)	(2)	(3)	(4)	(5)	(6)
i)	Long term	No Leakage	Test Temperature	$(60 \pm 2) ^\circ\text{C}$	Annex D

SI No.	Characteristic	Requirements	Tests					
			Parameter	Value	Reference			
(1)	(2)	(3)	(4)	(5)	(6)			
	internal pressure test for joint assembly		Type of test sample	End fitting – pipe – coupler – pipe – end fitting				
			Test Pressure	600 kPa (6 bars)				
			Test Duration	1 000 h				
ii)	Tensile Load	No leakage for one hour	Test temperature	(23±2) °C		Annex L		
			Type of test samples	End fitting – pipe – end fitting				
			Pipe length	350 mm				
			No. of test samples	2 per diameter class				
			Test Pressure	3 kPa (0.03 bar)				
			Tensile Strength Level	Class	Strength (KN)			
					1 h test		800 h test	
					1		1.4	0.7
					2		1.8	1.0
					3		2.1	1.4
4	4.0	2.4						
5	6.0	3.6						
6	8.0	4.8						
7	12.0	7.2						
iii)	Joint resistance to Crushing	Tightness No reduction of outer diameter more than 20percent	Test temperature	(23±2) °C		Annex M		
			Type of test sample	End fitting – pipe – end fitting				
			Pipe length	600 mm				
			Number of test samples	2 per diameter class				
			Test pressure	3 kPa (0.03 bar)				
			Force Level	2 kN				
			Position of load applied	10 mm from the insert of fitting or nut				
			Load	Plate with 150 mm side square				
iv)	Impact Resistance of the Joint	Tightness	Test Parameter	(23±2) °C		Annex N		
			Type of test sample	End fitting – pipe – coupler – pipe – end fitting with each end fitting fixed on a motionless support				
			Pipe length	1 000 mm each pipe				
			No of test sample	2 per diameter class				
			Test pressure	3 kPa (0.03 bar)				
			Striker	Spherical head with				

SI No.	Characteristic	Requirements	Tests		
			Parameter	Value	Reference
(1)	(2)	(3)	(4)	(5)	(6)
				1 cm of radius	
			Impact	600 mm height, 5 kg weight of striker	
			Position of the impact	On to the fitting	
v)	Thermal cycling resistance	No leakage	Extreme test temperature	(-20±2) °C / (60±2) °C	Annex P
			Number of cycles	10	
			Type of test samples	End fitting – pipe – coupler – pipe – end fitting assembled at (0±2)°C	
			Pipe length	300 mm each pipe	
			Number of test samples	2 per diameter class	
			Test pressures	10 kPa (0.10 bar); and 1.5 times MOP [Minimum of 600 kPa (6 bar)]	
vi)	Repeated bending Resistance	No damage or modification of the aluminium layer after the test	Minimum bend radius	As declared by the manufacturer	Annex Q
			Bend angle	90°	
			Number of bending cycles	3	
			Test pressure	3 kPa (0.03 bar)	
			Type of test samples	End fitting – pipe – end fitting	
			Pipe length	350mm	
			Position of the bend	At a distance equal to one minimum bend radius from the end fitting	
			Number of test samples	4 per diameter class	
vii)	Leak tightness	No leakage	Test temperature	(27±2) °C	Annex D
			Type of test sample	End fitting – pipe – coupler – end fitting	
			Pipe length	300 mm	
			Test pressure	750 kPa (7.5 bars)	
			Test duration	5 min	

8 SAMPLING, FREQUENCY OF TESTS AND CRITERIA FOR CONFORMITY

8.1 Type Test

8.1.1 Type tests are intended to prove the suitability and performance of a new composition, a new manufacturing technique or a new size of pipe. Such test need to be applied only when a change is made in polymer composition or method of manufacture, or when a new size is to be introduced. Even if no change is envisaged, type test shall be done at least once in three years of the highest size manufactured during the period.

8.1.2 Three samples selected at random shall be tested for compliance with the requirements of the type tests as given in Table 8.

8.1.3 If all the samples pass the requirements of the type test, the type of the pipe under consideration shall be considered eligible for type approval.

8.1.4 In case, any of the samples fail in the type test, the testing authority, at its discretion, may call for fresh samples not exceeding the original number and subject them to the type test again. If in repeat test, no single failure occurs, the type of pipe under consideration shall be considered eligible for type approval. If any of the samples fail in the repeat tests, the type of pipe shall not be approved. The manufacturer or the supplier may be asked to improve the design and resubmit the product for type approval.

8.1.5 At the end of the validity period (normally three years) or earlier as may be necessary, the testing authority may call for fresh samples for type-test for the purpose of type approval.

8.2 Acceptance Test

8.2.1 Acceptance tests are carried out on sample selected from a lot for the purpose of acceptance of the lot. The scale of sampling and criteria for conformity of a lot for acceptance tests specified in Table 8 shall be as given in **8.2.2**.

Table 8 Type and Acceptance Tests
(Clauses 8.1 and 8.2)

SI No.	Description of Test	Clause/ Table No.	Acceptance Test	Type Test
(1)	(2)	(3)	(4)	(5)
1	Base density	5.1.2; Table 2	✓	
2	Melt flow rate	5.1.2; Table 2	✓	
3	Oxidation induction time	5.1.2; Table 2	✓	
4	Visual appearance	5.2.1	✓	
5	Colour	5.2.2	✓	
6	Pigment dispersion	5.2.3	✓	
7	Pipe dimensions	5.5	✓	

SI No.	Description of Test	Clause/ Table No.	Acceptance Test	Type Test
(1)	(2)	(3)	(4)	(5)
8	Internal pressure creep rupture test (1 h and 10 h test)	5.6.1	✓	
9	Internal pressure creep rupture test (170 h test)	5.6.1		✓
10	Strength of joint line	5.6.2	✓	
11	Resistance to slow crack growth of the outer layer (cone test)	5.6.3		✓
12	Resistance to gas constituents	5.7 ; Table 5		✓
13	Thermal durability of the outer layer	5.7 ; Table 5		✓
14	Delamination	5.7 ; Table 5		✓
15	Odorant permeability	5.7 ; Table 5		✓
16	Long term internal pressure test of joint assembly	7.2 ; Table 7		✓
17	Tensile load	7.2 ; Table 7		✓
18	Joint resistance to crushing	7.2 ; Table 7	✓	
19	Impact resistance of the joints	7.2 ; Table 7	✓	
20	Thermal cycling resistance	7.2 ; Table 7		✓
21	Repeat bending resistance	7.2 ; Table 7	✓	

8.2.2 Scale of Sampling and Criteria for Conformity for Acceptance Test

8.2.2.1 Lot

All pipes/coils of the same size and manufactured essentially under similar conditions of manufacture with same grade of material shall constitute a lot.

8.2.2.2 For ascertaining the conformity of the lot to the requirement of this specification, samples shall be selected and acceptance tests as in Table 8 conducted in accordance with the provisions as given in 8.2.3 and 8.2.4 and tested for compliance.

8.2.3 Visual, Color and Dimensional Requirements

8.2.3.1 The number of test samples shall be in accordance with Table 9.

8.2.3.2 The pipes/coils shall be selected at random from the lot and in order to ensure the randomness of selection a random number table shall be used. For guidance and use of random number table, IS 4905 may be referred. In absence of a random number table the following procedure may be adopted:

Starting from any pipe in the lot, count them as 1,2,3,4 etc, up to r and so on where r is the integral part of N/n , N being the number of pipes in the lot and n is the number of pipes in the samples. Every r^{th} pipe so counted shall be drawn so as to constitute the required sample size.

8.2.3.3 The number of pipes given for the first sample in col 4 of Table 9 shall be examined for visual and dimensional requirements given in 5.2.1, 5.2.2 and 5.5. A pipe failing to satisfy any of these requirements shall be considered as defective. The lot shall be deemed to have satisfied these requirements, if the number of defectives found in the first sample are less than or equal to the corresponding acceptance number given in col 6 of Table 9. The lot shall be deemed not to have met these requirements, if the number of defectives found in the first sample is greater than or equal to the corresponding rejection number given in col 7 of Table 9. If however, the number of defectives found in the first sample lies between the corresponding acceptance and rejection numbers given in col 6 and col 7 of Table 9, second sample of size given in col 4 of Table 9 shall be taken and examined for these requirements. The lot shall be considered to have satisfied these requirements if the number of defectives found in the cumulative samples is less than or equal to the corresponding acceptance number given in col 6 of Table 9; otherwise not.

Table 9 Scale of Sampling for Visual and Dimensional Requirements
(Clause 8.2.3.1)

SI No.	No. of Pipes/Coils in the lot	Sample No.	Sample Size	Cumulative Sample Size	Acceptance No.	Rejection No.
(1)	(2)	(3)	(4)	(5)	(6)	(7)
i)	Up to 25	First	3	3	0	2
		Second	3	6	1	2
ii)	26 to 150	First	13	13	0	2
		Second	13	26	1	2
iii)	151 to 280	First	20	20	0	3
		Second	20	40	3	4
iv)	281 to 500	First	32	32	1	4
		Second	32	64	4	5
v)	501 to 1 200	First	50	50	2	5
		Second	50	100	6	7

8.2.4 The lot having satisfied dimensional and visual requirements shall be tested for internal pressure creep rupture test (1 h and 10 h), density, MFR, pigment dispersion, OIT, strength of joint line of pipe test requirements and joint resistance to crushing, impact resistance of joints and repeat bending test for pipe fitting joint test requirements.

8.2.4.1 A separate sample size for each of the tests shall be taken as stipulated in Table 10 and selected at random from the sample already examined for dimensional visual inspection and colour. All the pipes in each of the sample size shall be tested for compliance in the requirement for internal pressure creep rupture test for 1 h and for 10 h (see 5.6.1), density (see Table 1), MFR (see Table 1), pigment dispersion (see 5.2.3), OIT (see Table 1), strength of joint line (see 5.6.2), joint resistance to crushing (see Table 7), impact resistance of joints (see Table 7) and repeat bending resistance test (see Table 7) . The lot shall be considered to have met the requirements of these tests, if none of the sample tested fails.

Table 10 Scale of Sampling
(Clause 8.2.4.1)

SI No.	No. of Pipes/Coils in the Lot	Sample Size
(1)	(2)	(3)
i)	Up to 100	3
ii)	101 to 150	4
iii)	151 to 200	5
iv)	201 and above	8

9 MARKING AND DOCUMENTATION

9.1 Marking on Pipe

Each straight length or coil of pipe shall be clearly and legibly marked with any one of the following methods, such that the marking shall not initiate cracks or other types of failure in the product and the colour of the marking shall differ from that of the external pipe surface:

- a) Indelible inkjet print at every meter interval throughout the length of pipe/coil, or
- b) Laser print on at every meter interval throughout the length of pipe/coil.

Following minimum information shall be marked, and same shall be maintained during storage, handling, installation and use:

<i>SI No.</i>	<i>Aspect</i>	<i>Mark or Symbol</i>
i)	Name of the manufacturer or trade mark	Name or Symbol
ii)	Internal Fluid	Gas
iii)	Maximum operating pressure	500 kPa (5 bar)

iv)	Nominal pipe size	xx
v)	Material Designation	PE- AL-PE
vi)	Type and grade of PE material	PE80
vii)	Lot no. / Batch no.	As per 9.1.1
viii)	Reference to this Indian Standard	IS_____

9.1.1 The lot number/batch number shall include the details of production in the following manner:

Year	Month	Day	Machine No.	Shift
xxxx	xx	xx	xxx	x

9.2 Marking on Label

Two labels of suitable dimensions should be carefully attached to each coil/pipe bundles indicating:

- Manufacturer's name;
- Manufacturing standard;
- Material designation;
- Weight of coil/pipe bundle in kg; and
- Length of coil/each pipe length, in m.

9.3 Additional Instructions

The manufacturer shall provide clear assembly instructions that contains at least the following information:

- instructions that pipe and fitting(s) belong together and are not interchangeable with other products;
- statement if a fitting is fit for repeated assembly;
- if the manufacturer allows the use of a standard bending tool, a statement in the manufacturer's instructions that damage of the external coating shall be avoided while bending the pipe with standard bending tool;
- information on gaseous flow rate/pressure drop relationship;
- minimum bending radius;
- bending tools to be used; and
- if a calibration tool is necessary to insert a stiffener, the manufacturer instructions shall be given.

9.4 BIS Certification Marking

The pipes conforming to the requirements of this standard may be certified as per the conformity assessment schemes under the provisions of the Bureau of Indian Standards Act, 2016 and the Rules and Regulations framed thereunder, and the reinforcement coupler may be marked with the Standard Mark.'

FOR BIS USE ONLY

ANNEX A

(Table 2)

METHOD FOR DETERMINATION OF OXIDATION INDUCTION TIME

A-1 APPARATUS

A-1.1 A differential thermal analyser (DTA), calibrated using pure indium and pure tin to give values which lies within 156.6 ± 0.5 °C and 231.9 ± 0.5 °C respectively.

The test cell shall allow the cell to be purged within 1 min by use of successive gases at the specified flow rate.

A-1.2 Aluminium pans, large enough to accommodate a test piece in solid or molten form.

A-2 TEST PIECES

A sample shall be taken by use of a core drill directed radially through the pipe wall. The diameters of the core shall be just less than inner diameter of the sample pan of the thermal analyzer and care should be taken not to overheat the sample during the coring operation. Using a scalpel, test pieces that weigh 15 ± 0.5 mg shall be cut in the form of discs from the core sample, electing the inner surface and outer surface as the minimum sample points, which are then to be tested individually.

A-3 PROCEDURE

Except where the method given below differs, follow the operating instructions of the instrument manufacturer as applicable:

- a) Establish a nitrogen flow of 50 ml/min through the DTA cell. Check that when a switchover to nitrogen is made, the gas flow will continue at the rate and then revert to a nitrogen flow of 50 ml/min.
- b) Introduce a test piece in an open aluminium pan and an empty aluminium reference pan into the cell. Set the instrument to raise the temperature at a rate of 20 °C/min and then to run isothermally at 200 ± 0.1 °C. Start to record the thermogram (that is, a plot of the temperature differential against time).
- c) When steady condition exists under nitrogen after 5 min, switch over to oxygen and mark this point on the thermogram.
- d) Continue to run the thermogram until the oxidation exotherm has occurred and has reached its maximum.

A-4 INTERPRETATION OF THE RESULTS

The oxidation induction time for the test is the time taken, in min from the introduction of oxygen to the intercept of the extended base line and the extended tangent drawn to the exotherm at the point of maximum slope, as shown in Fig. 1.

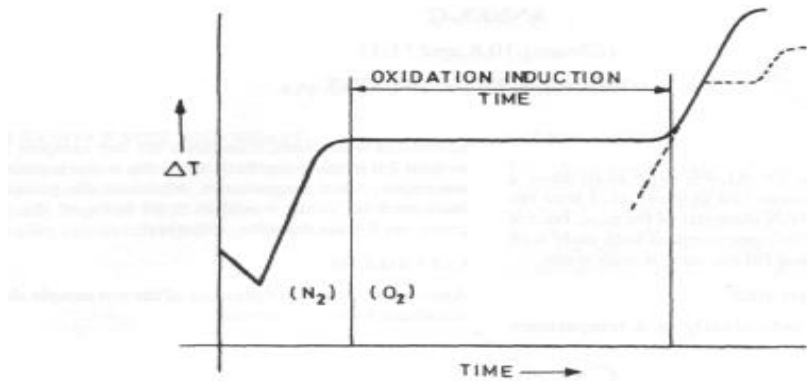

Fig. 1 Temperature Differential (ΔT) against Time

A-5 TEST REPORT

The test report shall include the following:

- a) identification of the test piece;
- b) a reference to this test method;
- c) individual results, in min; and
- d) date of the test.

FOR BISC

ANNEX B
(Clause 5.2.3)

**ASSESSMENT OF PIGMENT DISPERSION IN
POLYETHEYLENE PIPES: MICROTOME METHOD**

B-1 SCOPE

This annex describes the method for the assessment of pigment dispersion in polyethylene pipes.

B-2 PRINCIPLE

A microtome section of material is examined by transmitted light at a magnification of X100 and compared against standard photomicrographs.

B-3 APPARATUS

Apparatus required for the test are,

- a) *Microtome* — A microscope of at least X100 linear magnification and circular field of view of 0.7 ± 0.07 mm diameter set for transmitted light.
- b) *Microscope slides and cover slips*

B-4 TEST PIECE

Microtome section of 10 micron to 20 micron thick shall be cut from outer layer of the pipe. It shall have an area of approximately 7.0 mm^2 . Six test pieces shall be taken from different parts of the pipe length.

NOTE — It is often easier to take microtome sections if the pipe has been cooled to below room temperature.

B-5 PROCEDURE

- a) Place the pieces on a microscope slide so that each one is equidistant from its neighbour(s) and from adjacent edge(s) of the slide and cover with Canada balsam before placing a cover slip over the test pieces.
- b) Examine the six test pieces in turn through the microscope at a linear magnification of $X100 \pm 10$.
- c) Scan the whole of each test piece and compare the worst field of view of each with the standard photo-micrographs numbered 1 to 6 as shown in Fig. 2.
- d) Give to each of the six test pieces a numerical rating corresponding to the number of the photomicrograph equivalent to the worst field of view of each test piece.

B-6 EXPRESSION OF RESULTS

Record the rating of each test piece as per Fig. 2.

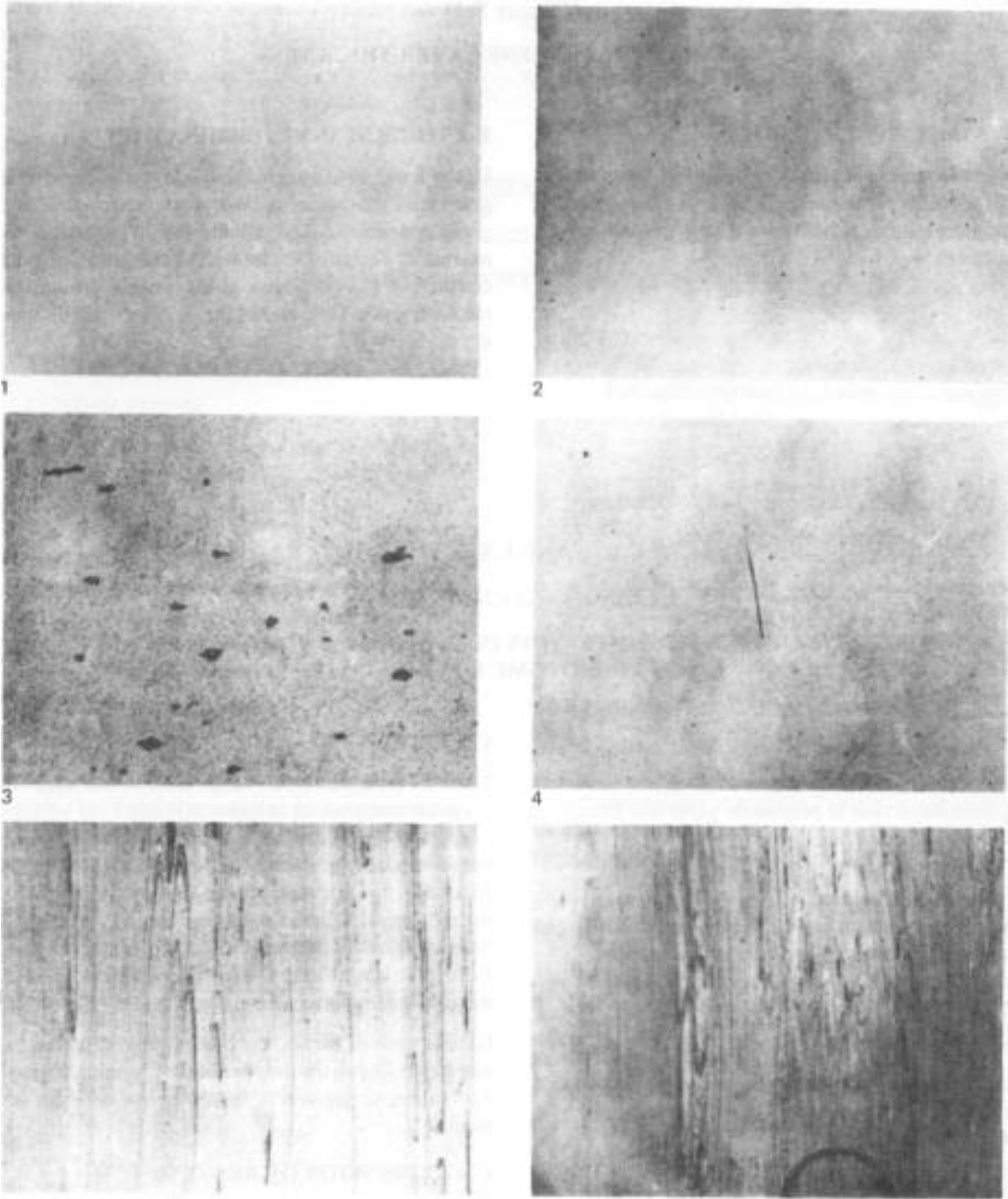

Fig. 2 Pigment Dispersion Photomicrograph 1 to 6

B-7 TEST REPORT

The test report shall include the following:

- a) Full identification of pipe or fitting from which the test pieces were taken,
- b) Individual rating of each test piece, and
- c) Date of testing.

FOR BIS USE ONLY

ANNEX C
(Clause 5.5.2.1)

OUTER POLYETHYLENE LAYER THICKNESS

C-1 SAMPLE PREPARATION

Select the sample of pipe at random. Cut the pipe with a sharp knife or other suitable cutter, ensuring that the pipe after cutting is not more than 1 percent out-of-roundness.

C-2 THICKNESS DETERMINATION

Use a hand held magnifying glass equipped with graduated reticule or a laboratory microscope with graduated reticule. The reticule should measure to the nearest 0.10 mm. Determine the thickness of outer coating of polyethylene at six points around the circumference. Only one of the points should be at the aluminium weld.

FOR BIS USE

ANNEX D
(Clause 5.6.1 and Table 7)

INTERNAL PRESSURE CREEP RUPTURE TEST

D-1 SAMPLES

Each test sample of PE-AL-PE pipe shall have a minimum length between end closures of at least ten times the average outside diameter of the pipe, but not less than 250 mm. Seal specimens at both ends with appropriate fittings and fill the sample with water.

D-2 TEST PROCEDURES

Test each sample individually in a temperature controlled water bath. Condition the test samples for at least 2 h in the water bath when the water bath is at the required test temperature. Maintain the pressure indicated in Table 4 within 0.07 MPa of the set pressures for the duration of the test.

D-3 FAILURE

Any continuous loss of pressure of the test sample shall constitute failure of the test.

FOR BIS USE

ANNEX E
(Clause 5.6.2)

TEST FOR DELAMINATION AND STRENGTH OF THE JOINT LINE

E-1 PRINCIPLE

Pipe samples are subjected to a cone test in order to determine delamination and strength of the joint line of the pipe sample. With a specially shaped cone, a defined expansion of the pipe is created.

E-2 PIPE SAMPLE

The test shall be carried out on a pipe sample with a length of at least 5 times d_e .

E-3 CONE

A cone with an angle of 15° shall be applied. The length of the cone shall be such that an expansion of the pipe end of 10 percent can be obtained.

E-4 PROCEDURE

The test shall be carried as per the procedure given below:

- a) Measure the real mean outside diameter of the pipe sample using suitable equipment with an accuracy of at least 0.1 percent.
- b) Multiply this value by 1.1 (10 percent expansion). This value is the outside diameter of the expanded part of the pipe sample.
- c) Measure the wall thickness of the pipe sample at eight separate points equally divided over the pipe diameter with an apparatus having an accuracy of at least 1 percent. The calculated value is e_m .
- d) Calculate d_{cone} , the required size of the cone diameter in order to obtain an expansion of 10 percent, using the formula, $d_{\text{cone}} = [1.1d_e - (2e_m)]$.
- e) Mark the place on the cones where a 10 percent expansion is expected.
- f) Insert the cone in the pipe sample up to the mark sign. The pipe end has been expanded now by 10 percent.
- g) Remove the cone.
- h) Wait 15 min after the removal of the cone and visually check the sample for cracks and delamination.

E-5 TEST REPORT

The test report shall include the following:

- a) number, type and nominal dimension of the sample;
- b) test temperature;
- c) cone dimensions;
- d) duration of the test;
- e) any observation made during and after the test; and
- f) any event able to influence the test results.

FOR BIS USE ONLY

ANNEX F
(Clause 5.6.3)

RESISTANCE TO SLOW CRACK GROWTH OF THE OUTER LAYER (CONE TEST)

F-1 PRINCIPLE

The test is conducted on a pipe produced from the material used for the outer layer of multilayer pipe. Rings cut from pipe to a specified length are held at a constant strain by insertion of a mandrel and a single notch is made at one end of the pipe ring. The assembly is immersed in a specified surface-active solution held at a temperature $80\text{ }^{\circ}\text{C} \pm 1\text{ }^{\circ}\text{C}$. The rate of growth of crack propagating from the notch is measured. The test is applicable to pipe of wall thickness up to and including 5 mm.

F-2 MATERIAL

Surface active solution of 5 percent Nonyl-phenoxy (ethyleneoxy) ethanol neutral type detergent mixed in de-ionized water (concentration by weight) shall be used.

F-3 APPARATUS

F-3.1 Thermostatically Controlled Tank

Thermostatically controlled tank to contain the surface active solution having dimensions to ensure full immersion of the specimen to be tested, shall have a lid to cover to prevent evaporation and a means of stirring the solution.

F-3.2 Cone

A mandrel of dimension as specified in Fig. 3 and with a conical end is required for insertion into the pipe ring to maintain a constant strain. At the end of the mandrel, there shall be a longitudinal groove of dimensions $20 \pm 1\text{ mm}$ by $1 \pm 0.2\text{ mm}$ and depth $2 \pm 0.2\text{ mm}$. The material used for manufacture of the mandrel shall not affect the surface active solution, brass for example.

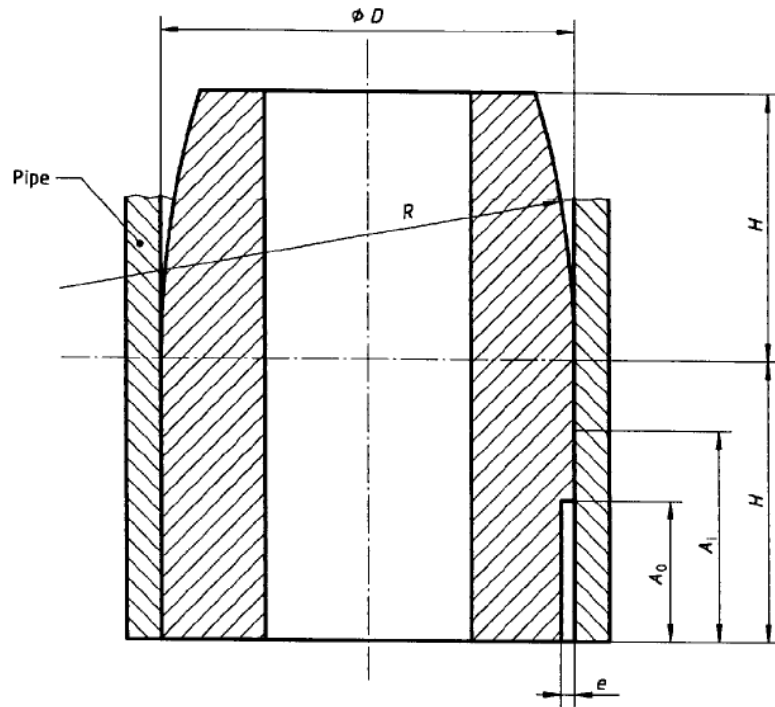

Key:

$D = 1.12$ times the nominal internal diameter of the pipe (± 0.1 mm);

$H = D$, for nominal outer diameter not exceeding 40 mm, and
 $= D/2$, for nominal diameters above 40 mm; and

$R = 4$ times the specified internal diameter of the pipe, for the pipe nominal size less than or equal to 40 mm, and
 $=$ nominal internal diameter of pipe for nominal size above 40 mm.

The nominal internal diameter is equal to the nominal pipe size less twice the specified minimum wall thickness

Fig. 3 Cone

F-3.3 Press or Vice

A press to drive the mandrel into the pipe ring at a rate which will not cause damage or distort the end or edges of the ring. Alternatively a vice with retaining and guiding jaws can be used.

F-3.4 Notching Device

A notching device is required which is capable of inserting a razor blade into the end of the pipe to create a notch, as shown in Fig. 4. Alternatively a mechanised means of performing

this operation, such as using a specialised jig or a machine with a moving table, is acceptable.

NOTE — A commercial razor blade shall be used for this operation, which shall be changed after not more than 20 notching operations. A blade penetration speed of around 10 mm/min is recommended.

F-4 Test Piece

Prepare three ring test pieces of 100 ± 5 mm length from a sample of pipe. Ensure that the ends of the ring are cut square. Measure the outer diameter (D_1) of the specimen 30 mm from the end of the pipe ring.

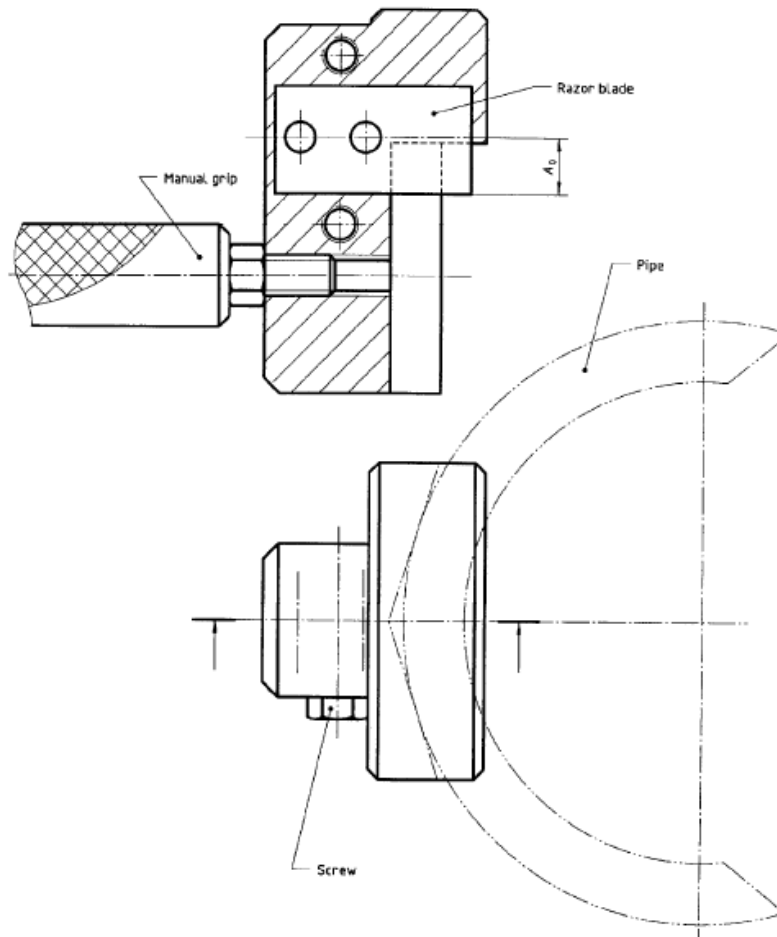

Fig. 4 Notching Device

F-5 PROCEDURE

F-5.1 Insertion of the Cone

Carefully insert the cone into the pipe ring ensuring axes of both are aligned. Using the press or vice, drive the mandrel fully into the pipe ring at a rate which shall not damage or distort

the end or edges of the ring. Re-measure the diameter (D_2) of the pipe in the same position 30 mm from the end.

Following insertion of the cone, the test piece shall be notched and immersed in the surface active solution within 10 min.

F-5.2 Calculation of Strain

Calculate the strain, using following formula and expressing the result as a percentage:

$$\text{Strain} = [(D_2 - D_1) \times 100]/D_1$$

F-5.3 Cutting of the Notch

A radial notch of axial length 10 ± 1 mm shall be cut through the pipe wall at the end of the pipe ring, which has been fully strained by the mandrel. The circumferential position of the mandrel groove relative to the pipe shall be marked. The notch shall be cut using the notching device.

To ensure that the notch is extended through the full wall thickness of the pipe ring specimen a press or vice shall be used to push the notching device into the ring.

Measure the axial length of the notch from the end of the pipe, $A_0 \pm 0.5$ mm.

NOTE — Mechanized means of cutting the notch is acceptable. For instance, the test assembly may be held in a tensile test machine or a special jig allowing the blade to form the notch in a controlled way. A cutting speed of around 10 mm/min is recommended.

F-5.4 Immersion of Test Piece

Introduce the test piece with inserted mandrel, after notching, into the tank containing the surface active solution, maintained at a constant temperature of 80 ± 1 °C. The test piece shall be positioned vertically in the tank, fully immersed, with the end of the mandrel sitting on the bottom of the tank, that is, with conical end facing upwards. The lid shall be placed on the tank and sealed.

F-5.5 Measurement of Crack Growth

The axial notch shall be examined after every 24 h. The appearance shall be noted and the length of the notch from the end of the pipe (A_1) shall be measured at each 24 h with precision of ± 0.5 mm. At least three successive increases in the notch length shall be obtained. If the notch growth curves away from an axial path significantly, the test shall be stopped and a new sample should be prepared.

NOTE — If no crack growth occurs after one week in the three test pieces, the test shall be stopped. The specimen of the pipe is deemed to be resistance to slow crack growth.

F-6 EXPRESSION OF RESULTS

Plot a graph of increase in crack length ($A_1 - A_0$) versus time, as shown in example in Fig. 5. Carry out linear regression for the data set. Determine the rate of growth (V mm/24 h) from the slope of this line for each test specimen. The highest rate of growth of crack shall be reported.

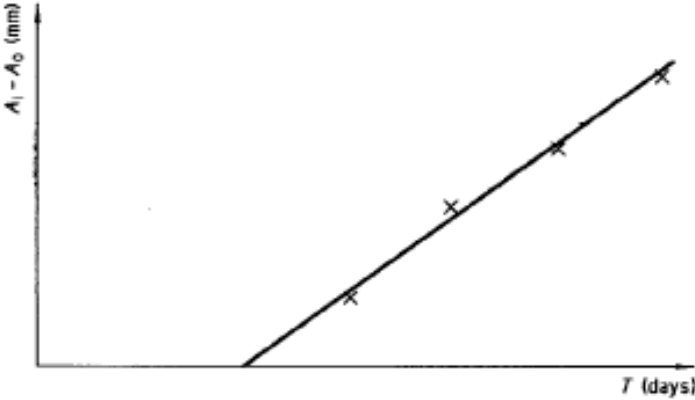

Fig. 5 Increase in crack length vs time

FOR BIS USE

ANNEX G
(Table 5)

RESISTANCE TO GAS CONSTITUENTS

G-1 PRINCIPLE

Specimens of pipe/fitting assemblies are filled with a liquid containing 50 percent *n*-decane and 50 percent 1,3,5- tri-methyl benzene under pressure for a specified period. After this conditioning period a cone test is carried out on the pipe as per **G-3.1** in order to determine the grade of delamination and an internal pressure test is carried out at 80 °C for a duration of 20 h as per **G-3.2** in order to determine the grade of delamination.

G-2 SPECIMEN

Prepare four specimens in accordance with IS 12235 (Part 8/Section 1). The test specimen should preferably be made of a pipe from dimension Class 6 (see **7.1**). The end caps shall be mounted in such a way that the condensate has free access to the pipe ends.

G-3 PROCEDURE

G-3.1 Cone test

The cone test shall be conducted as per the procedure given below:

- a) Prepare a synthetic condensate consisting of a mixture of a mass fraction of 50 percent *n*-decane (99 percent) and a mass fraction of 50 percent 1,3,5-trimethylbenzene.
- b) Condition the pipe by filling it with condensate and allowing it to stand in air for 1 500 h at 23 ± 2 °C with a pressure of $0.4 P_D$.
- c) Thereafter, the pipe shall be tested in accordance with Annex C, taking into account the dimensions of the pipe after conditioning.
- d) Check the specimen for leakage and for delamination of the layers.

G-3.2 Internal Pressure Test

The internal pressure test shall be conducted as per the procedure given below:

- a) Prepare a synthetic condensate consisting of a mixture of a mass fraction of 50 percent *n*-decane (99 percent) and a mass fraction of 50 percent 1,3,5-trimethylbenzene.
- b) Condition the pipe by filling it with condensate and allowing it to stand in air for 1 500 h at 23 ± 2 °C with a pressure of $0.4 P_D$.
- c) After the above procedure, an internal pressure test shall be carried out at 80 ± 2 °C for a duration of 20 h.
- d) Check the specimen for leakage and for delamination of the layers.

G-4 TEST REPORT

The test report shall include the following:

- a) number, type and nominal dimension of the specimen;
- b) test temperature;
- c) duration of the test;
- d) any observation made during and after the test; and
- e) any event able to influence the test results.

FOR BIS USE ONLY

ANNEX H
(Table 5)

THERMAL DURABILITY OF OUTER LAYER

H-1 PRINCIPLE

A pipe sample is stored in an oven for a defined time at an elevated temperature. After this oven aging, the test piece is bent to produce a required axial strain in the outside layer. The layer is observed visually for cracks.

H-2 APPARATUS

H-2.1 Hot air oven capable of maintaining $100 \pm 2^\circ \text{C}$ or $110 \pm 2^\circ \text{C}$.

H-2.2 Bending template, as shown in Fig. 6.

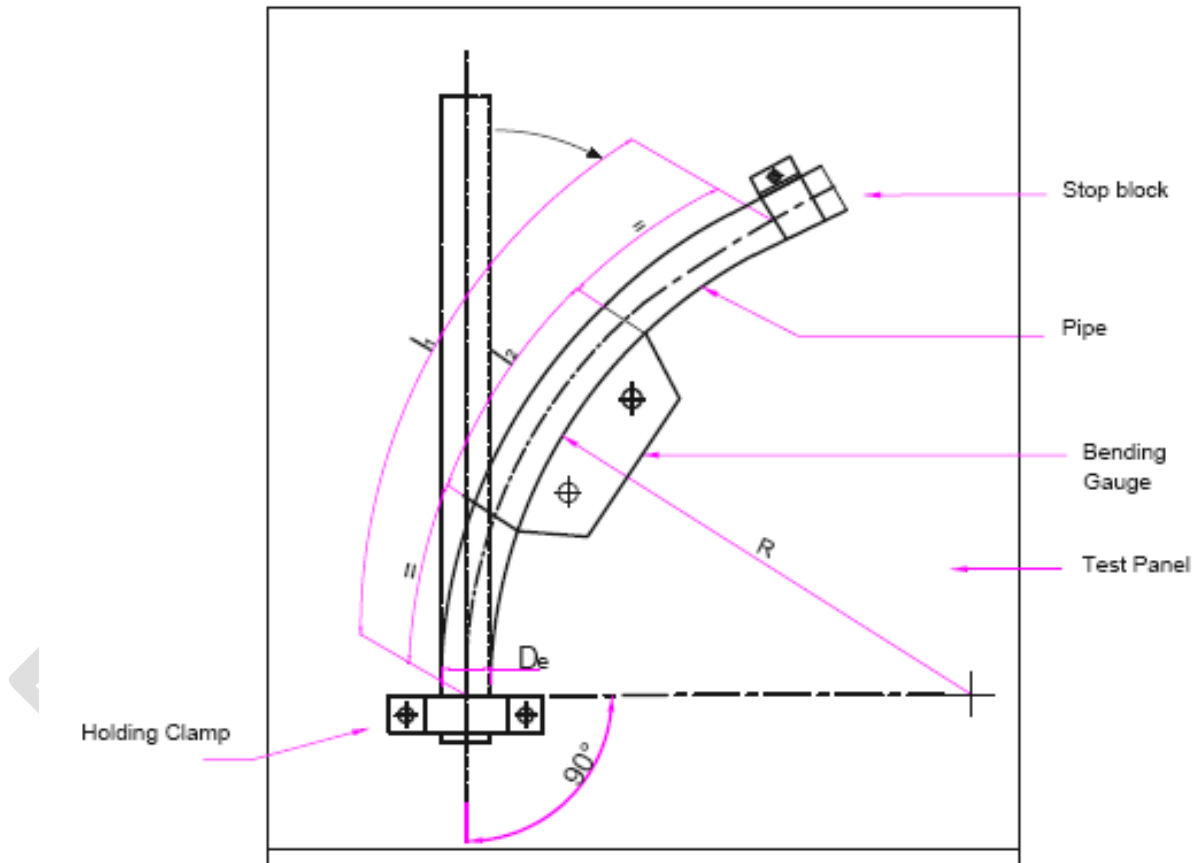

Fig. 6 Diagram of Typical Bending Apparatus

H-3 PROCEDURE

The test shall be carried out as per the procedure given below:

H-3.1 Age the Polyethylene (PE) in an oven for 0.5 years at $(100 \pm 2) ^\circ\text{C}$ or 0.25 years at $(110 \pm 2) ^\circ\text{C}$.

NOTE — This assumes a duration of 25 years at $60 ^\circ\text{C}$ during the 50 year lifetime of the pipe. Taken into account is the time/temperature extrapolation method of IS 16462/ISO 9080, which gives a test time of 0.5 years (6 months) at $100 ^\circ\text{C}$ or 0.25 years (3 months) at $110 ^\circ\text{C}$.

These oven aging times and temperatures are based on temperature profiles. The temperature variation is assumed as follows:

120 h at $70 ^\circ\text{C}$ per year, 3 months at $60 ^\circ\text{C}$, 3 months at $50 ^\circ\text{C}$, 3 months at $40 ^\circ\text{C}$ and 3 months at $30 ^\circ\text{C}$.

H-3.2 Deform the test piece by bending with bending template at $23 \pm 2 ^\circ\text{C}$ for a duration ranging from a minimum of 3 s to a maximum of 10 s (for complete deformation) and using the parameters as given below:

<i>Total Pipe Length</i> l_1	<i>Bending Length</i> l_2	<i>Bending Radius</i> R
10 d_e	7.5 d_e	16 d_e

Where, d_e is the outside diameter of the pipe.

A strain of 3 percent is required, equivalent to a bending radius of 16 d_e .

An example for calculating the relationship between bending radius and strain is given below:

EXAMPLE — For a pipe with 32 mm outside diameter, the required bending template radius is calculated as follows:

$$R = 16 \times d_e = 16 \times 32 \text{ mm} = 512 \text{ mm}$$

Strain of the outer layer in relation to the neutral axis of the pipe is calculated as follows:
 $\epsilon = \left[\frac{(R + d_e)}{(R + 0.5d_e)} - 1 \right] = \left[\frac{(17 \times d_e)}{(16.5 \times d_e)} - 1 \right] = 0.0303 = 3.0 \text{ percent}$

H-4 TEST REPORT

The test report shall include the following:

- number, type and nominal dimension of the sample;
- presence of cracks;
- duration of the test;
- any observation made during and after the test; and
- any event able to influence the test results.

ANNEX J
(Table 5)

ADHESION TEST (DELAMINATION TEST)

J-1 PRINCIPLE

Adhesion strength between layers of multilayer pipes is determined by a peel test using a pulling test rig. A tensile force is introduced to the metal (embedded) layer of a test piece perpendicular to the axial direction. This pulling force is measured. The test is carried out before and after thermal cycling.

J-2 PEEL TEST

J-2.1 Apparatus

J-2.1.1 Tensile Testing Machine

Tensile testing machine with cross head speed of $50 \text{ mm} \pm 5 \text{ mm}$ per min having measuring accuracy of 1 N is recommended.

J-2.1.2 Rotating Test Rig

For every pipe diameter (d_i), a support mandrel, having an outside diameter of $0.95 d_i$ and a length of at least $12 \pm 1 \text{ mm}$, able to rotate without significant resistance, preferably by the inclusion of a roller bearing, and a pulling rig, conforming to the principle as given in Fig. 7.

J-2.2 Sampling and Preparation of Test piece

Total 10 samples shall be cut from the pipe to be tested, equally divided over 1 m of the pipe. Each test piece shall be ring of width 10 mm cut from the pipe. The metal layer shall be cut in the axial direction and pulled lose over fixed length less than 12 mm to enable the clamp to be attached for pulling. For the location of the joint line, to neutralize the negative influence of the cutting, two series of tests shall be performed at different angles, α , as given below:

- a) For Test 1, the angle, α shall be $135^\circ \pm 5^\circ$, see Fig. 7; and
- b) For Test 2, the angle α shall be $315^\circ \pm 5^\circ$.

This test shall be carried out keeping the joint in the center of the test rings in both the tests.

J-2.3 Procedure

- a) The test shall be conducted at $23 \pm 2 \text{ }^\circ\text{C}$.
- b) Insert the support axle into the test piece and ensure free rotation of test piece.
- c) Install the clamp on the lose part and check that the angle α is as required for Test 1 and Test 2.
- d) Apply a cross-head spread speed of $50 \pm 5 \text{ mm/min}$.

e) Record the applied force, F_p , over the angle of rotation 30° to 255° during the test.

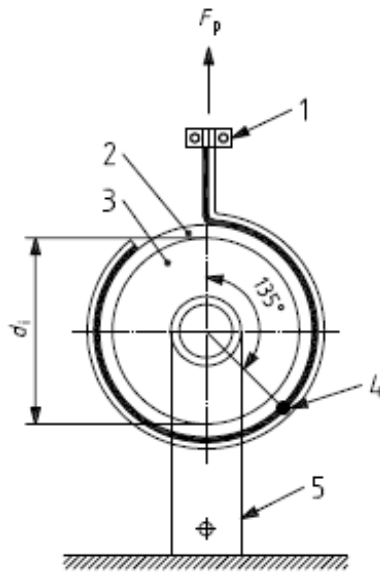

Key

- 1 Clamp
- 2 Inner layer
- 3 Support axle that includes a roller bearing
- 4 Weld line
- 5 Pivoted sample holder

Fig. 7 Pulling Rig

J-2.4 Processing of Test Result

For all 10 samples, the minimum value of F_p is recorded as the peel strength.

J-3 DELAMINATION TEST

J-3.1 Sample

Samples for peel test and for thermal cycling shall be prepared in accordance with J-2.2 and Annex P, respectively. All samples shall be prepared from the same pipe.

J-3.2 Procedure

The test shall be conducted as per the procedure given below:

- a) Carry out a peel test according to J-2 at $23 \pm 2^\circ\text{C}$.
- b) Carry out a thermal cycle test according to Annex P, with a thermal cycle between -20°C and 60°C . The number of cycles shall be 10. The pipe is to be pressurized.

- c) After the thermal cycling, a test sample shall be prepared for the peel test according to **J-2.2** and peel test shall be carried out according **J-2** at 23 ± 2 °C. The peeling zones should be at the ends and center of the test piece.

J-4 TEST REPORT

The test report shall include the following:

- a) peel strength, expressed in N/cm;
- b) name of the test;
- c) number, type and nominal dimension of the sample; and
- d) test temperature.

FOR BIS USE ONLY

ANNEX K
(Table 5)

ODORANT PERMEABILITY TEST

K-1 PRINCIPLE

A flow with a defined concentration of THT (see Note) is conveyed through a pipe sample. After a defined period, the THT permeability through the pipe wall will be detected by an experienced person.

NOTE — THT (Tetrahydrothiophene) is the most common type of odorant that is added to the gas for safety reasons. A customer can detect small gas leakages by smelling. Any other odorant permitted by statutory authorities may also be used for this test.

K-2 SAMPLES

Each end of a pipe is fitted with a valve. The length of the pipe is such that the distance between the valves shall be $250 \text{ mm} \pm 10 \text{ mm}$.

K-3 PROCEDURE

The test is conducted as per the method given below:

- a) An air flow with a THT concentration of 100 mg/m^3 at a pressure of $0.1 \pm 0.02 \text{ MPa}$ is passed through the pipe at a temperature of $23 \pm 2 \text{ }^\circ\text{C}$.
- b) After 60 days of exposure an experienced observer has to detect the presence of THT odour.

K-4 TEST REPORT

The test report shall include the following:

- a) detection of THT odour;
- b) delamination and leakage;
- c) number, type and nominal dimension of the sample;
- d) test temperature;
- e) duration of the test;
- f) any observation made during and after the test; and
- g) any event able to influence the test results.

ANNEX L
(Table 7)

RESISTANCE TO TENSILE LOAD ON JOINTS

L-1 PRINCIPLE

Samples of pipe/fitting joint are subjected to a tensile load in order to establish the short and long term resistance to tensile loads.

L-2 SAMPLES

A sample consists of a pipe with two end fittings. One fitting shall have a possibility to establish a pressure connection. The free length of pipe between the end fittings shall be 350 mm \pm 10 mm.

L-3 PROCEDURE

L-3.1 Short-term (1 h) Test

The test is conducted as per the procedure given below:

- a) Carry out testing at an ambient temperature of 23 ± 2 °C.
- b) Put the test sample in the tensile testing machine.
- c) Apply 3 kPa (0.03 bar) pressure and maintain it up to the completion of the test.
- d) Raise the tensile load until the specified value for various classes as given in Table 7 has been attained, in such a way that the test piece is pulled at a speed of 0.1 l/min \pm 0.05 l/min, where l is 350 mm.
- e) Keep the tensile load constant for 1 h while monitoring the pressure.

L-3.2 Long-term (800 h) test

The test is conducted as follows:

- a) Carry out testing at an ambient temperature of 23 ± 2 °C.
- b) Put the test sample in a constant load apparatus.
- c) Apply the load as given for various classes in Table 7.
- d) Keep the tensile load constant for 800 h while monitoring the pressure.
- e) For the short-term test, pressure inside the samples is monitored and any leakage should be recorded along with the location and time of appearance.
- f) For the long-term test, pressurise the sample after test period with a pressure of 3 kPa (0.03 bar).
- g) Check the sample for leakage.

L-4 TEST REPORT

The test report shall include the following:

- a) type of the sample;
- b) air pressure (initial pressure, pressure vs time plotting);
- c) any leakage occurring during the phase (time of occurrence, strain/strength at the moment of the leak, failure description); and
- d) any problem during the test able to influence the result of the test.

FOR BIS USE ONLY

ANNEX M
(Table 7)

CRUSH TEST ON JOINTS

M-1 PRINCIPLE

Pipe crushing in the vicinity of a pipe joint is considered as critical. In order to determine the resistance to crushing, a pipe sample is crushed very close to a pipe joint. After the test, a tightness test is carried out.

M-2 SAMPLES

The test sample is made of an end-fitting, pipe and end-fitting and the joints are made in accordance with the manufacturer's instructions. The pipe length shall be $600 \text{ mm} \pm 10 \text{ mm}$.

M-3 PROCEDURE

The test is conducted as follows:

- a) Perform a tightness test at 3 kPa (0.03 bar).
- b) Apply a load on a plate (a square with 150 mm sides) positioned close to the fitting (10 mm from the insert of the fitting or nut) to obtain a force level of 2 kN (see Fig. 8). This can be achieved in a tensile testing machine.

Alternatively, the plate can be a square with 75 mm sides and in that case a force level of 1 kN shall be applied.

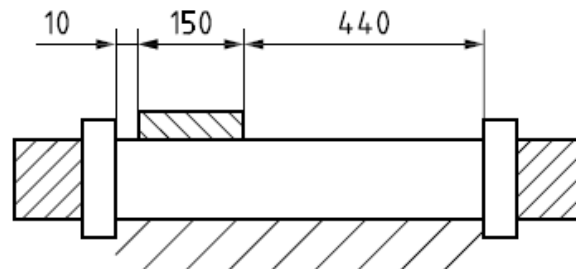

(All dimensions in millimetres.)

Fig. 8 Resistance to crushing close to fitting test assembly

- c) Wait for the strain to be constant.
- d) Check the tightness.
- e) Perform a visual observation.
- f) Control the test sample on tightness by applying a test pressure of 10 kPa (0.10 bar).

- g) Remove the load.
- h) Measure the pipe diameter 5 min after removing the load and calculate the remaining deformation.

M-4 TEST REPORT

The test report shall include the following:

- a) number, type and nominal dimension of the sample;
- b) test temperature;
- c) crushing force;
- d) duration of the test;
- e) any observation made during and after the test; and
- f) any event able to influence the test results.

FOR BIS USE ONLY

ANNEX N
(Table 7)

IMPACT RESISTANCE TEST ON JOINTS

N-1 PRINCIPLE

The impact resistance of joints is determined by the impact of a falling striker of defined dimensions and mass dropped from a defined height.

N-2 PIPE SAMPLES

The test sample is made of an end-fitting, pipe, coupling, pipe-end fitting. The joints are made in accordance with the manufacturer's instructions. Each pipe length shall be 1 000 mm \pm 20 mm.

N-3 SHAPE AND MASS OF STRIKER

The striker shall have a spherical head with a radius of 10 mm and a mass of 5 kg (see Fig. 9).

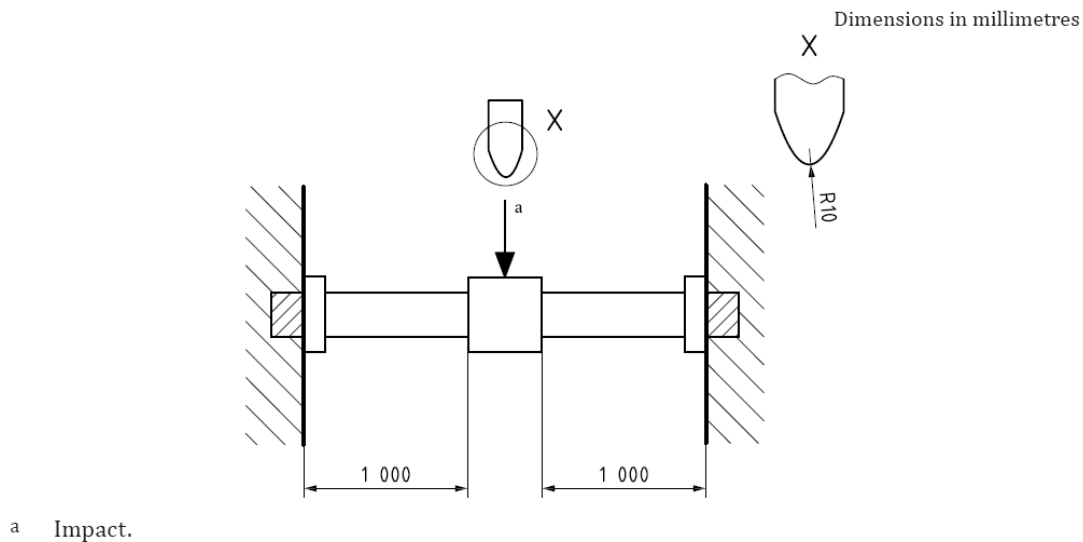

Fig. 9 Impact resistance test assembly

N-4 PROCEDURE

The test shall be carried out as below:

- a) Each end fitting is fixed on a motionless support.
- b) Perform a tightness test at 100 kPa (1 bar).
- c) Drop a striker from a height of 600 mm on the middle of the fitting
- d) Perform a tightness test at 100 kPa (1 bar).
- e) Check the sample for leakage by means of a foaming solution.

N-5 TEST REPORT

The test report shall include the following:

- a) leakage/no leakage;
- b) name of the test;
- c) number, type and nominal dimension of the sample; and
- d) test temperature.

FOR BIS USE ONLY

ANNEX P
(Table 7)

THERMAL CYCLING ON JOINTS

P-1 PRINCIPLE

To establish the negative influence of cycles of low and high temperatures, a sample of a pipe with fittings will be subjected to a number of thermal cycles. The sample will be pressurised. The leak rate is determined by measuring the pressure before and after the test.

P-2 SAMPLES

A sample consists of the combination of an end-fitting, pipe, coupling, pipe, end-fitting.

P-3 PROCEDURE

The test is conducted as follows.

- a) The test samples shall be conditioned at a temperature of 0 °C for a conditioning time greater than 1 h.
- b) Pressurise the sample with a pressure of 10 kPa (0.01 bar) air pressure at 0°C.
- c) Pressurise another sample with a pressure of 1.5 MOP with a minimum of 600 kPa (6 bar) air pressure at 0 °C.
- d) Place the samples in an appropriate oven and apply the heat cycle as given in Fig. 10, for $N = 10$ times.
- e) Check the samples for leakage at 0 °C after the thermal cycling, measure the pressure drop.

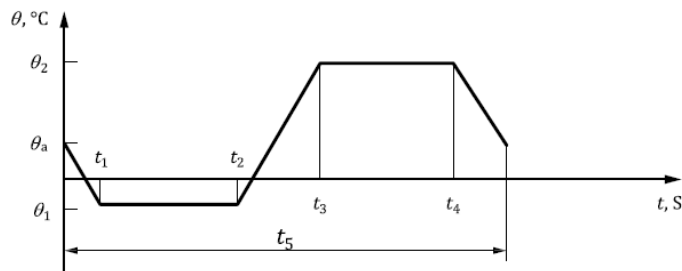

Key:

θ	Temperature	T	time
θ_1	-20 °C	t_1	$(\theta_1 - \theta_a)$ min
θ_2	60 °C	t_2	$t_1 + 3$ h
θ_a	Ambient temperature	t_3	$t_2 + 90$ min
a	Rate of temperature change is 1 °C/min.	t_4	$t_3 + 3$ h
		t_5	1 cycle, ~9 h

Fig. 10 Heat Cycle Layout

P-4 TEST REPORT

The test report shall include the following:

- a) Type of sample;
- b) Type of Test;
- c) Air pressure (initial pressure, pressure after thermal cycling);
- d) Leakage/no leakage

FOR BIS USE ONLY

ANNEX Q
(Table 8)

REPEATED BENDING TEST

Q-1 PRINCIPLE

Using a special dimensioned mandrel, the resistance to repeat bending is determined of samples from pipe fitting assemblies. After the bending procedure, the leak tightness is determined.

Q-2 SAMPLES

The test sample is made of an end-fitting, pipe, end-fitting under 3 kPa (0.03 bar) test pressure with one end fixed and the other end free.

Q-3 SPECIAL TOOLS

A special tool (spring or bending tool) can be used, if required.

Q-4 PROCEDURE

The test is conducted as follows:

- a) The test sample should be put between two mandrels as shown in Fig. 11.
- b) The mandrel radius is the minimum bend radius, that is, the pipe radius where the minimum bend radius is declared by the manufacturer. The welded seam is on the inside of the bend.
- c) Bend the pipe from position A to position B. The time between positions A and B should be around 10 s. Wait half a minute.
- d) Put the pipe back into the position A.
- e) Repeat steps (c) and (d) two times.
- f) Check during the test if delamination of the layer has occurred.
- g) Peel off the outer PE layer of the pipe and observe for any damage to the aluminium layer.
- h) The pipe may be rotated in different positions during examination to improve the damage detection. Inspect visually for any delamination such as blisters, pitting and notches.

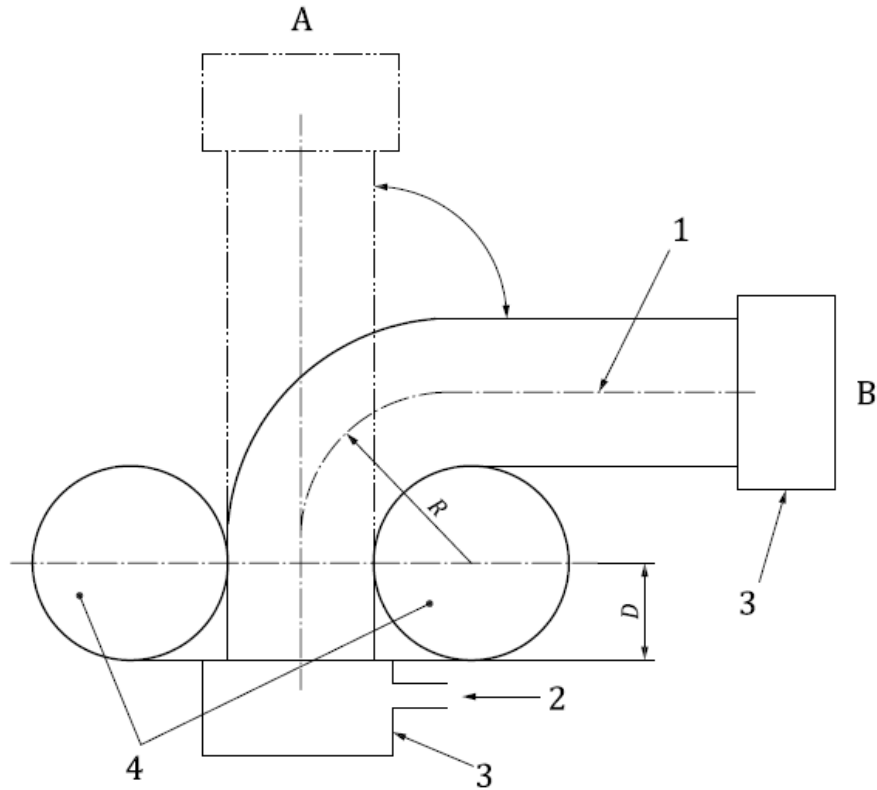

Key

- A unbent position
- B bent position
- 1 pipe longitudinal axis
- 2 air source; pressure sensor plug
- 3 end-fittings
- 4 mandrels
- R bend radius
- D minimum bend radius

Fig. 11 Repeated bending test assembly

Q-5 TEST REPORT

The test report shall include the following:

- a) type of sample;
- b) air pressure (initial pressure, pressure vs. time plotting);
- c) any leakage occurring during the test (time of occurrence, number of bends done, location);
- d) any event during the test which could influence the result of the test.

ANNEX R
(Foreword)

**SUPPLY, PACKAGING, HANDLING, TRANSPORTATION AND INSTALLATION OF
MULTILAYER (PE-AL-PE) PIPE SYSTEMS FOR INDOOR GAS INSTALLATIONS**

R-1 SUPPLY AND PACKAGING

R-1.1 The multilayer (PE-AL-PE) pipes shall be supplied either as self-supporting coils or, straight length (either independent or bundled together), or as agreed between the supplier and the purchaser. Their ends shall be cleanly cut, square with the axis of pipe and protected against shocks and ingress of foreign bodies by appropriate end caps.

R-1.1.1 *Coils*

R-1.1.1.1 Multilayer (PE-AL-PE) pipes supplied in coiled form should be stored flat or vertically in purpose-built racks or cradles, if desired by purchaser. Consideration should be given for facilities, which avoid single point contact of the coils.

R-1.1.1.2 The dimensions of the coils shall conform to requirements given in **5.4.4**. The maximum width of any coil shall be 0.55 m. Maximum external surface temperature at the time of coiling should not be more than 35 °C.

R-1.1.1.3 All coiled pipe shall be constrained in a stable configuration by banding with PP/HDPE strap at least at three equispaced positions during production. The banding shall be sufficiently stable to prevent movement.

R-1.1.1.4 Coiled pipe shall preferably be packed in woven fabric bags or wrapped with woven fabrics. The fabric shall be of HDPE or PP, suitably compounded with 2.0 to 3.0 percent of Carbon black or equivalent material to protect the pipe from damages and from UV degradation.

R-1.1.2 *Bundles*

R-1.1.2.1 In case of multilayer (PE-AL-PE) pipes supplied in straight length bundled form, the distance (X) between the supporting frames shall be equally spaced in order to allow stacking (see Fig. 12). Such pipes shall rest evenly over their whole length. The supporting frame shall not be nailed together and shall be constructed such as to lead the pressure load directly through the supporting frame and not through the multilayer pipes.

R-1.1.2.2 The pipe bundles shall preferably be packed in woven fabric lay-flat tube or wrapped with woven fabric. The woven fabric shall be of HDPE or PP, suitably compounded with 2.0 to 3.0 percent of Carbon black or equivalent material to protect the pipe from damages and from UV degradation.

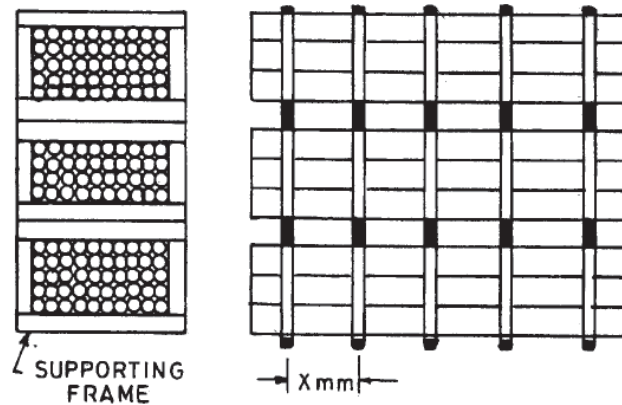

Fig. 12 Stacking Arrangement of Straight length pipes

R-1.2 Identification

Two labels of suitable dimensions shall be attached with each coils or bundles indicating all information given in 9.2. Marking on labels shall be indelible.

R-2 HANDLING

R-2.1 General

The pipes shall not be dragged or thrown along the ground. In case handling equipment is not used, appropriate techniques which are not likely to damage the pipe should be chosen.

R-2.1.1 Straight Pipe

Initial handling and storage of multilayer straight pipes should be made with the pipe in packaged form, thus minimizing damage during this phase. When loading, unloading or handling, it is preferable to use mechanical equipment to move or stack the packs.

R-2.1.2 Coils

Individual coils shall not be rolled off the edge of the loading platforms or trailers. These coils may be kept on pallets and loaded, off-loaded using forklifts, pallet trolley etc.

R-3 TRANSPORTATION

R-3.1 Straight Lengths

When transporting straight multilayer PE-AL-PE pipes, use flat bed vehicles with a partition. The bed shall be free from nails and other protuberances. The pipes or pipe bundles shall rest uniformly in the vehicle over their whole length. The vehicles shall have side supports appropriately spaced 2 m apart, and the multilayer pipes shall be secured effectively during transportation. All posts shall be flat with no sharp edges. During transportation, the

multilayer pipes should be continuously supported such as to minimize movement between the pipes and their supports. Also being relatively soft outer layer, poor handling techniques may result in gauges, scratches, cuts or puncture.

R-3.2 Coiled Pipe

Coiled pipe may be supplied on pallets. The coils should be firmly strapped to the pallets, which should in turn be firmly secured to the vehicle. There should be facilities to restrain each coil securely throughout transit and the loading process.

To save on transport cost nesting of coils/straight length can be considered if agreed between the purchaser and the supplier.

R-4 STORAGE

R-4.1 Pipes shall be stored in the manner to prevent damage from elevated temperature, contact with chemicals, and prolonged exposure to direct sunlight. If the pipes are to be stored outside, the recommendations on maximum storage time limits and maximum temperature exposure shall be consulted from the manufacturers/or as per the recommendations of the manufacturers. Non-ventilated covering of the pipe to protect it against UV exposure may sometimes create excessive heat which may also be detrimental to the pipe performance.

R-4.2 In case of outside storage, the cumulative exposure period should be determined with reference to the pipe production code, which includes the date of manufacture. By using this date, allowance is also made for exposure received during storage by the manufacturer.

R-4.2.1 It is recommended that multilayer pipes should not be stored outside for more than 2 years. Where individual pipe lengths and coils are stacked in pyramidal fashion, deformation may occur in the lower layers, particularly in warm weather. Therefore, such stacks should not exceed a height of 1 500 mm.

R-4.3 The multilayer pipes shall be stacked on a reasonably flat surface, free from sharp objects, stones or projections likely to deform or damage them.

R-5 FIRST IN-FIRST OUT

In general, most manufacturers store the multilayer pipes outside prior to shipment. Issuing from store on a 'first in-first out' can minimize the exposure time rotation with the extrusion date used as control. The polyethylene pipe with the earliest extrusion date should be issued for first installation.

R-6 INSTALLATION PROCEDURE

R-6.1 End Preparation for Jointing

End preparation should be done as below:

- a) *Cutting of pipe* – Always use right pipe cutter to ensure burr free cutting. It is necessary that the cut is always at the right angle. Hold the pipe firmly to ensure the right angle cut.
- b) *Rounding of pipe* – Use suitable size of rounding tool to make the pipe is properly rounded.
- c) *Chamfering of pipe* – Chamfer the end of the pipe so that O-ring is not damaged during insertion.

R-6.2 Jointing Procedure using Brass Internal Sealing Fittings

The jointing using brass internal sealing fittings shall be carried out in the manner given below (see also Fig. 13):

- a) Fittings should be of the same make and compatible with the pipes to be joined.
- b) Remove the nut and split ring from fitting. Ensure that O-rings in the fitting are in good condition.
- c) Place the nut and split ring over the pipe.
- d) Insert the pipe fully inside the groove over the insert.
- e) Push the split ring until it touches the shoulder of the fitting.
- f) Tighten the nut fully using proper size spanner.
- g) Use Spark Proof tools in case working near flammable gas installation.

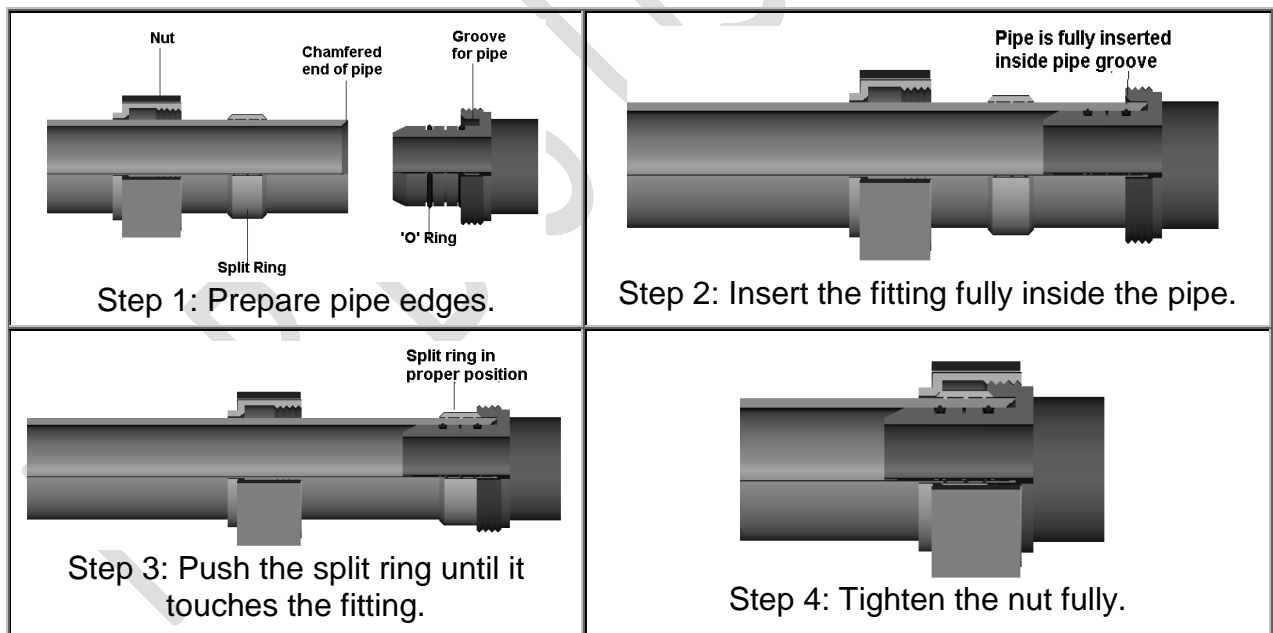

Fig. 13 Jointing using Brass Internal Sealing Fittings

R-6.3 Bending Procedure

The following should be ensured while bending the pipes:

- a) Use suitable internal/external bending spring (see Fig. 14).
- b) Bending radius should be more than 5 times the outside diameter of the pipe.

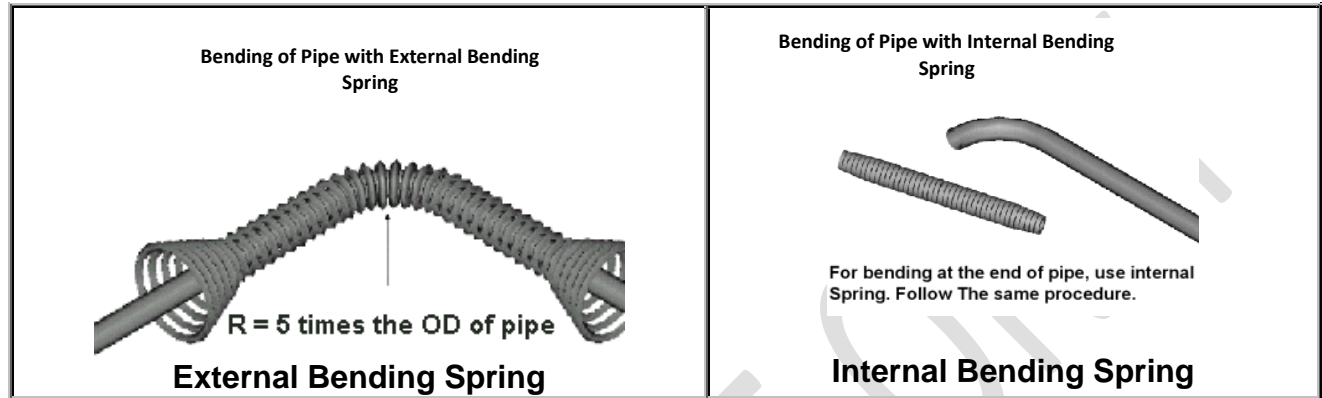

Fig. 14 Bending Spring

R-6.4 Clamping of Pipes

The following should be ensured while clamping the pipes:

- a) Maintain the clamping distances as mentioned in the table.
- b) Always support the fittings at all the joints.
- c) Use proper clamps for supports.

<i>Sl No.</i>	<i>Pipe Size</i>	<i>Horizontal m</i>	<i>Vertical m</i>
(1)	(2)	(3)	(4)
i)	14	0.80	1.00
ii)	16	0.80	1.00
iii)	20	0.80	1.00
iv)	25	1.00	1.00
v)	32	1.20	1.20
vi)	40	1.20	1.40
vii)	50	1.40	1.60
viii)	63	1.60	1.80
ix)	75	1.80	2.00

R-6.5 Testing of for Gas Tightness

The installation shall be tested for gas tightness as below:

- a) Ensure that the installation is disconnected at the meter or from the cylinder.
- b) Ensure all open ends are plugged or capped.
- c) Ensure all gas appliances are isolated.
- d) Connect a suitable test instrument.
- e) Pressurize the consumer piping to 1.5 times the operating pressure (maximum can be 750 kPa).
- f) Isolate the pressure source and allow a suitable period (say 2 min) for the temperature of the testing medium within the consumer piping to stabilize.
- g) Measure the loss of pressure during a test period of 5 min.
- h) The pipe work can be considered gas tight and the test as satisfactory if there is no loss of pressure during the test period of 5 min.

R-6.6 Concealing the Installation of PE-Al-PE Pipe

The installation of multilayer PE- AL-PE pipe shall be concealed in the following manner:

- a) The pipe shall not be in contact with sharp objects.
- b) The environment around it shall be non-corrosive to PE and material of fittings.
- c) Fittings and joints shall be installed in suitable inspection chambers with covers that are perforated or have slits over at least 20 percent of the chamber cover to allow any gas to come out of the chambers.
- d) There should be no annular space around pipes that are concealed.
- e) If pipe is installed in a conduit, the annular space between the pipe and the conduit shall be filled with inert material so that no gas can accumulate or pass through the annular space.