



भारतीय मानक ब्यूरो

(उपभोक्ता मामले, खाद्य एवं सार्वजनिक वितरण मंत्रालय, भारत सरकार)

BUREAU OF INDIAN STANDARDS

(Ministry of Consumer Affairs, Food & Public Distribution, Govt. of India)

मानक भवन, 9, बहादुर शाह ज़फर मार्ग, नई दिल्ली - 110002

Manak Bhawan, 9, Bahadur Shah Zafar Marg, New Delhi - 110002

Phones: 23230131 / 2323375 / 23239402

Website: www.bis.gov.in, www.manakonlin.in

व्यापक परिचालन मसौदा

हमारा संदर्भ : सीईडी 43/टी-10

23 अगस्त 2024

तकनीकी समिति : मृदा एवं नींव इंजीनियरिंग अनुभागीय समिति 43

प्राप्तकर्ता :

- सिविल अभियांत्रिकी विभाग परिषद, सीईडीसी के सभी सदस्य
- मृदा एवं नींव इंजीनियरिंग अनुभागीय समिति 43 और इसकी उपसमितियों के सभी सदस्य
- रुचि रखने वाले अन्य निकाय।

महोदय/महोदया,

निम्नलिखित मानक का मसौदा संलग्न है:

प्रलेख संख्या	शीर्षक
सीईडी 43(26408)	भारतीय मानक मसौदा मृदा — परीक्षण पद्धतियाँ: भाग 2 जल मात्रा का निर्धारण [आई एस 2720 (भाग 2) का तीसरा पुनरीक्षण] (आईसीएस 93.020, 13.080.20)

कृपया इस मसौदे का अवलोकन करें और अपनी सम्मतियाँ यह बताते हुए भेजे कि यह मसौदा प्रकाशित हो तो इन पर अमल करने में आपको व्यवसाय अथवा कारोबार में क्या कठिनाइयां आ सकती हैं।

सम्मतियाँ भेजने की अंतिम तिथि: 27 सितंबर 2024

सम्मति यदि कोई हो तो कृपया अधोहस्ताक्षरी को ई-मेल द्वारा ced43@bis.gov.in पर या उपरलिखित पते पर, संलग्न फॉर्मेट में भेजें। सम्मतियाँ बीआईएस ई-गवर्नेंस पोर्टल, www.manakonlin.in के माध्यम से ऑनलाइन भी भेजी जा सकती हैं।

यदि कोई सम्मति प्राप्त नहीं होती है अथवा सम्मति में केवल भाषा संबंधी त्रुटि हुई तो उपरोक्त प्रालेख को यथावत अंतिम रूप दे दिया जाएगा। यदि सम्मति तकनीकी प्रकृति की हुई तो विषय समिति के अध्यक्ष के परामर्श से अथवा उनकी इच्छा पर आगे की कार्यवाही के लिए विषय समिति को भेजे जाने के बाद प्रालेख को अंतिम रूप दे दिया जाएगा।

यह प्रालेख भारतीय मानक ब्यूरो की वेबसाइट www.bis.gov.in पर भी उपलब्ध है।

धन्यवाद।

भवदीय

ह/-

द्वैपायन भद्र

वैज्ञानिक ई एवं प्रमुख

सिविल अभियांत्रिकी विभाग

ई-मेल: ced43@bis.gov.in

फोन: +91-11 23608594

संलग्न: उपरलिखित



भारतीय मानक ब्यूरो

(उपभोक्ता मामले, खाद्य एवं सार्वजनिक वितरण मंत्रालय, भारत सरकार)

BUREAU OF INDIAN STANDARDS

(Ministry of Consumer Affairs, Food & Public Distribution, Govt. of India)

मानक भवन, 9, बहादुर शाह ज़फर मार्ग, नई दिल्ली - 110002
Manak Bhawan, 9, Bahadur Shah Zafar Marg, New Delhi - 110002
Phones: 23230131 / 2323375 / 23239402
Website: www.bis.gov.in

WIDE CIRCULATION DRAFT

Our Reference: CED 43/T-10

23 August 2024

TECHNICAL COMMITTEE: Soil and Foundation Engineering Sectional Committee, CED 43

ADDRESSED TO:

1. All Members of Civil Engineering Division Council, CEDC
2. All Members of Soil and Foundation Engineering Sectional Committee, CED 43 and its Subcommittees
3. All others interested.

Dear Sir/Madam,

Please find enclosed the following draft:

Doc No.	Title
CED 43(26408)	Draft Indian Standard for Soils — Methods of Test: Part 2 Determination of Water Content [<i>Third Revision of IS 2720 (Part 2)</i>] ICS: 93.020, 13.080.20

Kindly examine the attached draft and forward your views stating any difficulties which you are likely to experience in your business or profession, if this is finally adopted as National Standard.

Last Date for Comments: 27 September 2024

Comments if any, may please be made in the enclosed format and emailed at ced43@bis.gov.in or sent at the above address. Additionally, comments may be sent online through the BIS e-governance portal, www.manakonline.in.

In case no comments are received or comments received are of editorial nature, kindly permit us to presume your approval for the above document as finalized. However, in case comments, technical in nature are received, then it may be finalized either in consultation with the Chairman, Sectional Committee or referred to the Sectional Committee for further necessary action if so desired by the Chairman, Sectional Committee.

The document is also hosted on BIS website www.bis.gov.in.

Thanking you,

Yours faithfully,

Sd/-

Dwaipayan Bhadra

Scientist 'E' & Head

Civil Engineering Department

Email: ced43@bis.gov.in

Phone: +91-11 23608594

Encl: As above

FORMAT FOR SENDING COMMENTS ON THE DOCUMENT

[Please use A4 size sheet of paper only and type within fields indicated. Comments on each clause/sub-clause/ table/figure, etc, be stated on a fresh row. Information/comments should include reasons for comments, technical references and suggestions for modified wordings of the clause. **Comments through e-mail to ced43@bis.gov.in shall be appreciated.**]

Doc. No.: CED 43(26408)

BIS Letter Ref: CED 43/T-10

Title: Draft Indian Standard for Soils — Methods of Test: Part 2 Determination of Water Content
[Third Revision of IS 2720 (Part 2)]

ICS: 93.020, 13.080.20

Last date of comments: **27 September 2024**

Name of the Commentator/ Organization: _____

SI No.	Clause/ Para/ Table/ Figure No. commented	Type of Comment (General/ Technical/ Editorial)	Comments/ Modified Wordings	Justification of Proposed Change
1.				
2.				
3.				
4.				
5.				
6.				
7.				
8.				
9.				
10.				
11.				
12.				

NOTE- Kindly insert more rows as necessary for each clause/table, etc.

BUREAU OF INDIAN STANDARDS

DRAFT FOR COMMENT ONLY

(Not to be reproduced without the permission of BIS or used as a Standard)

Draft Indian Standard for

SOILS — METHODS OF TEST
PART 2 DETERMINATION OF WATER CONTENT
[Third Revision of IS 2720 (Part 2)]

Soil and Foundation Engineering
Sectional Committee, CED 43

Last date for Comments:
27 September 2024

FOREWORD

(Formal clauses to be added later)

With a view to establishing uniform procedure for the determination of different characteristics of soils, Indian Standards on methods of test for soils (IS 2720) have been formulated in various parts. This standard (Part 2) has been published to cover the methods of test of soil for determination of water content.

This Standard (Part 2) was first published in 1964 and revised in 1969 to include two rapid field methods for the determination of water content in soils. In the second revision of the standard, rapid determination of water content with infra-red lamp torsion balance moisture meter and rapid determination of water content from the gas pressure developed by the reaction of calcium carbide with the free water content of the soil were included.

This revision of the standard has been taken up to update it so as to take into account current practice for determination of water content of soil. The subsidiary methods for determination of water content of soil, namely alcohol method and sand bath method which used to give inaccurate and inconsistent results and were earlier suggested for rapid determination of water content at field, have been deleted.

In the formulation of this standard due weightage has been given to international co-ordination among the standards and practices prevailing in different countries in addition to relating it to the practices in the field in this country.

For the purpose of deciding whether a particular requirement of this standard is complied with, the final value, observed or calculated, expressing the result of a test or analysis shall be rounded off in accordance with IS 2: 2022 'Rules for rounding off

numerical values (*second revision*). The number of significant places retained in the rounded off value should be the same as that of the specified value in this standard.

BUREAU OF INDIAN STANDARDS**DRAFT FOR COMMENT ONLY**

(Not to be reproduced without the permission of BIS or used as a Standard)

*Draft Indian Standard for***SOILS — METHODS OF TEST
PART 2 DETERMINATION OF WATER CONTENT***[Third revision of IS 2720 (Part 2)]*Soil and Foundation Engineering
Sectional Committee, CED 43Last date for Comment:
27 September 2024**1 SCOPE**

1.1 This standard (Part 2) covers the determination of water content of soil expressed in percentage of dry weight by (a) oven-dry method (b) rapid determination of water content with infra-red lamp torsional balance moisture meter, and (c) rapid determination of water content from the gas pressure developed, by the reaction of calcium carbide with the free water of the soil.

NOTE – For accurate and reliable results, the oven-dry method shall only be followed.

2 REFERENCES

The Indian Standards given below contain provisions which through reference in this text, constitute provision of this standard. At the time of publication, the editions indicated were valid. All standards are subject to revision, and parties to agreements based on this standard are encouraged to investigate the possibility of applying the most recent editions of the standards.

<i>IS No.</i>	<i>Title</i>
IS 460	Specification for test sieves:
Part 1:1985	Wire cloth test sieves (<i>third revision</i>)
Part 2:1985	Perforated plate test sieves (<i>third revision</i>)
Part 3:1985	Methods of examination of apertures of test sieves (<i>third revision</i>)
IS 2809:1972	Glossary of terms relating to soil dynamics (<i>first revision</i>)

3 TERMINOLOGY

For the purpose of this standard, the definitions given in IS 2809 shall apply.

SECTION 1 OVEN-DRY METHOD

4 PRINCIPLE

This method covers the determination of the water content of a soil as a percentage of its oven-dried soil mass.

5 APPARATUS

5.1 Container – Any suitable non-corrodible air-tight container.

5.2 Balance – Of sufficient sensitivity to weigh the soil samples to an accuracy of 0.04 percent of the mass of the soil taken for the test (see 6.1).

5.3 Oven – Thermostatically controlled, with interior of non-corroding material to maintain the temperature at 105 °C to 110 °C.

5.4 Desiccator– A desiccator with any suitable desiccating agent.

6 SOIL SPECIMEN

The soil specimen taken shall be representative of the soil mass. The size of the specimen selected depends on the quantity required for good representation, which is influenced by the gradation and the maximum size of particles, and on the accuracy of weighing. The following quantities are recommended for general laboratory use:

<i>Size of Particle More than 90 Percent Passing</i>	<i>Minimum Quality of Soil Specimen to be Taken for Test Mass in g</i>
425 micron IS Sieve	25
2 mm IS Sieve	50
4.75 mm IS Sieve	200
10 mm IS Sieve	250
20mm IS Sieve	500
40 mm IS Sieve	1 000

NOTES:

1. For size of sieves, see IS 460 (Parts 1 to 3).
2. Drier the soil, the greater shall to be the quality of the soil taken.
3. Water content specimen should be discarded and should not be used in other test.

7 PROCEDURE

7.1 Clean the container with lid, dry and weigh (W_1). Take the required quantity of the

soil specimen in the container crumbled and placed loosely, and weigh with lid (W_2). Then keep it in an oven with the lid removed, and maintain the temperature of the oven at 105 to 110 °C (see Note). Dry the specimen in the oven for 24 h. Every time, the container is taken out for weighing, replace the lid on the container and cool the container in a desiccator. Record the final mass (W_3) of the container with lid with dried soil sample.

NOTE – Oven-drying at 105 to 110 °C does not result in reliable water content values for soil containing gypsum or other mineral having loosely bound water of hydration or for soil containing significant amounts of organic material (see also 8.2). Reliable water content value for these soils can be obtained by drying in an oven at approximately 60 to 80 °C.

8 CALCULATION

The percentage of water content shall be calculated as follow:

$$w = \frac{W_2 - W_3}{W_3 - W_1} \times 100$$

where,

w = water content in percent,

W_1 = mass of container with lid in g,

W_2 = mass of container with lid with wet soil in g, and W_3 = mass of container with lid with dry soil in g.

9 REPORT

9.1 The water content (w) of the soil shall be reported to two significant figures in percent.

9.2 The result of the test shall be suitably recorded. A recommended *proforma* for this record is given in Annex A.

SECTION 2 RAPID DETERMINATION OF WATERCONTENT WITH INFRA-RED LAMP TORSIONALBALANCE MOISTURE METER

10 PRINCIPLE

10.1 This section describes a method for rapid determination of water content of soils employing a device providing infrared lamp for drying and torsional balance for getting of percentage of water on wet basis from a scale, and the results obtained are convertible to water content on dry basis.

NOTE – The water estimation with this method takes 15 to 30 min depending upon the type of soil and quantity of water present. Plastic soils might take about 30 min. The reproducibility of readings is within ± 0.25 percent. The probable error is about ± 0.3 percent of water content in case of granular soils and about 0.8 to 1 percent in case of clays.

11 APPARATUS

- a) Infrared Lamp and Torsional Balance Moisture Meter — The moisture meter is illustrated in its essential details in Fig. 1 and Fig. 2.

The equipment should be of two main parts, the infrared lamp, and the torsional balance. The infrared radiation should be provided by 250 W lamp built in the balance for use with an alternating current 220-230 V, 50 cycle, single phase mains supply. Provision should be made to adjust the input voltage to the infrared lamp to control the heat for drying of specimen. A suitable thermometer graduated from 40 to 150 °C should be provided for ascertaining the temperature of drying in the pan housing. The weighing mechanism, a torsional balance, should have a built-in magnetic damper. The balance scale should be divided in terms of water percentage, from 1 to 100 percent of water content in 0.2 percent divisions.

- b) Palette Knife or Steel Spatula — having a blade 10 cm long and 2 cm wide.

12 SOIL SAMPLE

The soil sample taken shall be representative of the soil mass. The sample should weigh 25 g. As the moisture meter is calibrated to use 25 g of soil, the maximum size of particle present in the sample shall be less than 2 mm.

13 PROCEDURE

13.1 Keep the test samples always in suitable containers so that the water content to be determined is not affected by ambient conditions.

100 percent (this represents the amount of unbalance). The pointer will now be above the index mark.

- d) Raise the lamp housing and carefully distribute the test material evenly on the sample pan until the pointer returns to the index mark (25 g of the material will be needed in one operation).
- e) Lower the lamp housing and switch on the infrared lamp with the help of the switch provided on the left-hand side. Insert the thermometer in its socket and bracket. Adjust the variac control knob between 95 and 100 on the scale, if it is desired that the temperature of drying is around 110 °C. The sample will now begin to lose water and the pointer will rise above the index.

NOTE – Keep a watch on the column of mercury on the thermometer when the thermometer records a temperature of 105 °C. Control the variac in such a manner that there is no more rise in the temperature beyond 110 °C and the temperature in the housing is maintained at 105 °C to 110 °C. If for a particular sample, the temperature is to be higher or lower than 110 °C, the variac control knob can be adjusted accordingly.

- f) To determine the percentage reduction of mass at any instant, rotate the drum scale by turning the drum drive knob until the pointer returns to the index. Read the percentage directly from the scale. The percentage water content which is read from the scale is the percentage of water content based upon the initial mass of the sample, that is, the wet mass of the sample.
- g) The criterion for taking the final reading is that the pointer should remain steady on the index mark which shows that the sample has dried to constant mass. Note the drum scale reading against the pointer which is the percentage of water content on the total mass taken. Remove the thermometer from its bracket.
- h) Repeat steps **13.1** to **13.8** with a fresh sample using a cool and clean pan.

14 CALCULATION

From the percentage of water content (m) as obtained on the moisture balance scale, the percentage of water content (w), on the dry weight basis shall be calculated as follows:

15 REPORT

The water content and the results of tests shall be reported in accordance with **9.1** and **9.2**.

SECTION 3 RAPID DETERMINATION OF WATER CONTENT FROM THE GAS PRESSURE DEVELOPED BY THE REACTION OF CALCIUM CARBIDE WITH THE FREE WATER OF THE SOIL

16 PRINCIPLE

This section describes a method for rapid determination of water content from the gas pressure developed by the reaction of calcium carbide with the free water of the soil. From the calibrated scale of the pressure gauge, the percentage of water on total (wet) mass of soil is obtained and the same is converted to water content on dry mass of soil.

17 APPARATUS

17.1 Metallic Pressure Vessel – with clamp for scaling cup, and a gauge calibrated in percentage water content (see Fig. 3).

17.2 Counter poised Balance – for weighing sample as shown in Fig. 3.

17.3 Scoop – for measuring absorbent (calcium carbide).

17.4 One Bottle of the Absorbent (calcium carbide).

17.5 One Cleaning Brush

17.6 Steel Balls – three steel balls of about 12.5 mm diameter and one steel ball of 25 mm diameter.

18 SOIL SPECIMEN

Sand requires no special preparation. Coarse powders may be ground and pulverized. Cohesive and plastic soils and material are tested with addition of steel balls in the pressure vessels. This test requires about 6 g of soil sample.

19 TEST PROCEDURE

19.1 Set up the balance. Place sample in pan till the mark on the balance arm mass lines up with the index mark.

19.2 Unclamp the clamping screw of the instrument sufficiently to move the U-clamp off the cup. Lift off the cup. Check that the cup and the body are clean; otherwise clean it using a brush.

19.3 Hold the body horizontal and gently deposit one level scoopful of absorbent (calcium carbide) halfway inside the chamber. Then lay the chamber down without disturbing the absorbent charge. Transfer the soil weighed out as above from the pan to the cup. Holding cup and chamber approximately horizontal bring them together without

disturbing sample or absorbent, bring the U-clamp round and clamp the cup tightly into place.

NOTE – If the sample is bulky, reverse the above placements, that is, put the sample in the chamber and the absorbent in the cup. In the case of clayey soils and pastes, place the 3 smaller steel balls in the cup along with the sample and the larger one in the body along with the absorbent.

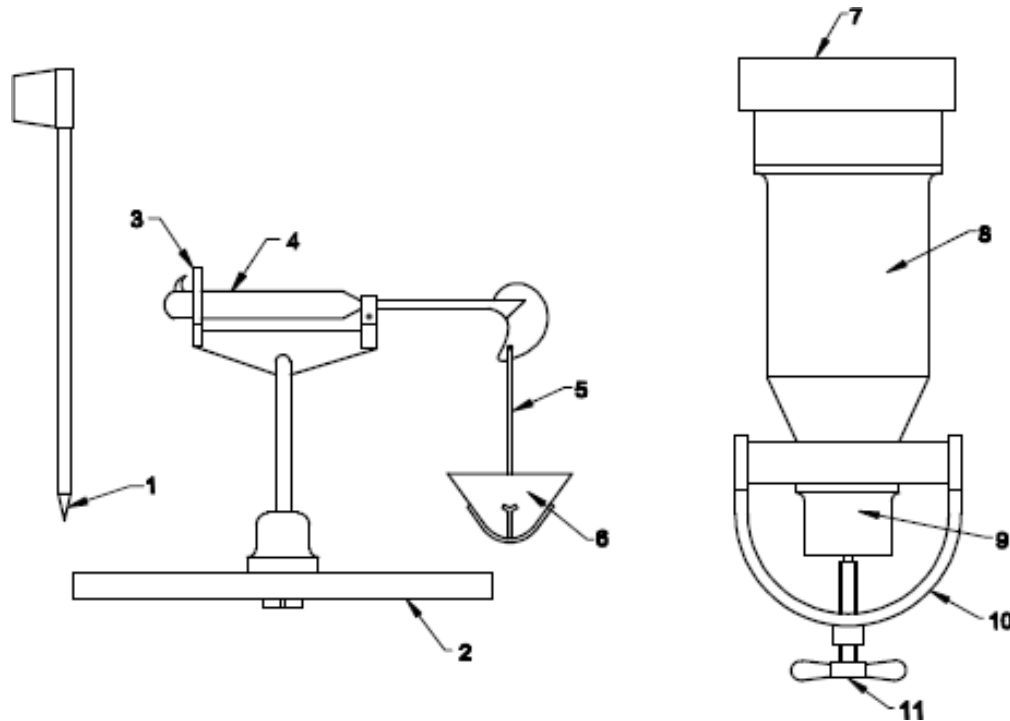

- | | |
|----------------|-----------------------|
| 1 Scoop | 7 Gauge, 0.50 percent |
| 2 Balance base | 8 Chamber |
| 3 Index mark | 9 Cup |
| 4 Balance arm | 10 U-clamp |
| 5 Stirrup | 11 Clamp screw |
| 6 Pan | |

Fig. 3 Rapid Moisture Meter

19.4 With gauge downwards (except when the steel balls are used) shake the moisture meter up and down vigorously for 5 s, then quickly turn it so that the gauge is upwards, give a tap to the body of the moisture meter to ensure that all the contents fall into the cup. Hold the rapid moisture meter downwards, again shake for 5 s, then turn it with gauge upwards and tap. Hold for one minute. Repeat this for a third time. Once more invert the rapid moisture meter and shake up and down to cool the gas. Turn the rapid moisture meter with the gauge upwards and dial horizontal held at chest height. When the needle comes to rest, take the reading. The readings on the meter are the

percentage of water content on the wet mass basis.

NOTE – When steel balls are used, place the 3 smaller balls in the cup along with the sample and the larger one in the chamber along with the absorbent and seal up the unit as usual. Hold the rapid moisture meter vertical so that the material in the cup falls into the chamber. Now holding the unit horizontal, rotate it for 10 s so that the balls are rolled round the inside circumference of the chamber. Rest for 20 s. Repeat the rotation-rest cycle until the gauge reading is constant (usually this takes 4 to 8 min). Note the reading as usual.

19.5 Finally release the pressure slowly (away from the operator) by opening the clamp screw and taking the cup out, empty the contents and clean the instrument with a brush.

20 CALCULATION

From the percentage of water content (m) obtained on the wet mass basis as the reading on the rapid moisture meter, the percentage of water content (w) on the dry mass basis shall be calculated as follows:

NOTE -The absorbent is highly susceptible to absorption of moisture and shall not be exposed to atmosphere; as a result the absorbent suffers deterioration and will give results on the lower side. Replace the lid of the absorbent container firmly as soon as the required amount of the absorbent for a test is taken from the bottle. The absorbent suffers deterioration with time.

ANNEX A
(Clause 9.2)

**PROFORMA FOR RECORD OF RESULTS OF TEST FOR THE DETERMINATION OF
WATER CONTENT OF SOIL**

Details of soil sample:

Tested by:

Method of test adopted:

Oven drying:

1. Container No. :
2. Mass of container with lid, W_1 , in g :
3. Mass of container with lid and wet soil W_2 , in g :
4. Mass of container with lid and dry soil W_3 , in g :
5. Mass of dry soil ($W_3 - W_1$), in g :
6. Mass of moisture ($W_2 - W_3$), in g :
7. Water content $w = \frac{W_2 - W_3}{W_3 - W_1} \times 100$: