



भारतीय मानक ब्यूरो BUREAU OF INDIAN STANDARDS

MANAK BHAVAN, 9 BAHADUR SHAH ZAFAR MARG, NEW DELHI 110002
Phone: + 91 11 23230131, 23233375, 23239402 Extn 8406, 23608406; Website: www.bis.gov.in

व्यापक परिचालन मसौदा

हमारा संदर्भ : सीईडी 38/टी-15

03 फरवरी 2023

तकनीकी समिति : विशेष संरचना विषय समिति सीईडी 38

प्राप्तकर्ता :

- क) सिविल इंजीनियरी विभाग परिषद, सीईडीसी के सभी सदस्य
- ख) विशेष संरचना विषय समिति, सीईडी 38 एवं इसके उपसमितियों के सभी सदस्य
- ग) रुचि रखने वाले अन्य निकाय।

महोदय/महोदया,

निम्नलिखित मसौदा संलग्न है:

प्रलेख संख्या	शीर्षक
सीईडी 38 (21888) WC	प्राकृतिक प्रवात काउंटर प्रवाह कूलिंग टावरों के थर्मो-द्रवचालित डिजाइन के लिए दिशानिर्देश का भारतीय मानक मसौदा (नया भारतीय मानक मसौदा) ICS No. 27.060.30

कृपया इस मसौदे का अवलोकन करें और अपनी सम्मतियाँ यह बताते हुए भेजे कि यह मसौदा प्रकाशित हो तो इन पर अमल करने में आपको व्यवसाय अथवा कारोबार में क्या कठिनाइयाँ आ सकती हैं।

सम्मतियाँ भेजने की अंतिम तिथि: 08 मार्च 2023

सम्मति यदि कोई हो तो कृपया अधोहस्ताक्षरी को ई-मेल द्वारा abhishek.pal@bis.gov.in पर या उपरलिखित पते पर, संलग्न फॉर्मेट में भेजें। टिप्पणियाँ बीआईएस ई-गवर्नेंस पोर्टल, www.manakonline.in के माध्यम से ऑनलाइन भी भेजी जा सकती हैं।

यदि कोई सम्मति प्राप्त नहीं होती है अथवा सम्मति में केवल भाषा संबंधी त्रुटि हुई तो उपरोक्त प्रलेख को यथावत अंतिम रूप दे दिया जाएगा। यदि सम्मति तकनीकी प्रकृति की हुई तो विषय समिति के अध्यक्ष के परामर्श से अथवा उनकी इच्छा पर आगे की कार्यवाही के लिए विषय समिति को भेजे जाने के बाद प्रलेख को अंतिम रूप दे दिया जाएगा।

यह प्रलेख भारतीय मानक ब्यूरो की वेबसाइट www.bis.gov.in पर भी उपलब्ध है।

धन्यवाद।

भवदीय

ह/-

(अरुण कुमार एस.)

प्रमुख (सिविल इंजीनियरिंग)

संलग्न: उपरलिखित

**भारतीय मानक ब्यूरो**
BUREAU OF INDIAN STANDARDS

MANAK BHAVAN, 9 BAHADUR SHAH ZAFAR MARG, NEW DELHI 110002
Phone: + 91 11 23230131, 23233375, 23239402 Extn 8406, 23608406; Website: www.bis.gov.in

DRAFT IN WIDE CIRCULATION

Our Ref: CED 38/T-15

03 February 2023

TECHNICAL COMMITTEE: Special Structures Sectional Committee, CED 38**ADDRESSED TO:**

- All Members of Civil Engineering Division Council, CEDC
- All Members of Special Structures Sectional Committee, CED 38 and its Sub Committees
- All other interests

Dear Sir/Madam,

Please find enclosed the following draft:

Doc. No.	Title
CED 38 (21888) WC	Draft Indian Standard Thermo-Hydraulic Design of Natural Draught Counter Flow Cooling Towers – Guidelines (New Draft Indian Standard) ICS No. 27.060.30

Kindly examine the attached draft and forward your views stating any difficulties which you are likely to experience in your business or profession, if this is finally adopted as National Standard.

Last Date for Comments: 08 March 2023

Comments if any, may please be made in the enclosed format and emailed at abhishek.pal@bis.gov.in or sent at the above address. Additionally, comments may be sent online through the BIS e-governance portal, www.manakonline.in.

In case no comments are received or comments received are of editorial nature, you will kindly permit us to presume your approval for the above document as finalized. However, in case comments, technical in nature are received, then it may be finalized either in consultation with the Chairman, Sectional Committee or referred to the Sectional Committee for further necessary action if so desired by the Chairman, Sectional Committee.

The document is also hosted on BIS website www.bis.gov.in.

Thanking you,

Yours faithfully,

Sd/-

(Arun Kumar S.)
Head (Civil Engineering)

Encl: As above

FORMAT FOR SENDING COMMENTS ON BIS DOCUMENTS

(Please use A-4 size sheet of paper only and type within fields indicated. Comments on each clause/sub-clause/table/fig etc. be started on a fresh box. Information in column 3 should include reasons for the comments and suggestions for modified working of the clauses when the existing text is found not acceptable. Adherence to this format facilitates Secretariat's work) {Please e-mail your comments to abhishek.pal@bis.gov.in

Doc. No.: **CED 38 (21888) WC**

TITLE: Draft Indian Standard 'Guidelines for Thermo-Hydraulic Design of Natural Draught Counter Flow Cooling Towers'

ICS No. 27.060.30

LAST DATE FOR COMMENTS: 08/03/2023

NAME OF THE COMMENTATOR/ORGANIZATION: _____

Sl. No.	Clause/Para/Table/ Figure No. Commented	Comments/Modified Wordings	Justification of the Proposed Change

BUREAU OF INDIAN STANDARDS

DRAFT FOR COMMENTS ONLY

(Not to be reproduced without the permission of BIS or used as an Indian Standard)

Draft Indian Standard

**THERMO-HYDRAULIC DESIGN OF NATURAL DRAUGHT COUNTER FLOW
COOLING TOWERS – GUIDELINES**

ICS No. 27.060.30

Special Structures Sectional Committee,
Sectional Committee, CED 38

Last date for comments:
08/03/2023

FOREWORD

(Formal clauses to be added later)

This draft guideline on the thermo-hydraulic design of natural draught counterflow cooling towers (NDCTs) is published for the benefit of purchasers / end users and also designers in the field.

Presently, each tower manufacturer/contractor has a different basis to arrive at a design solution to a given thermal duty using different types of fills, most of the time proprietary, and offers different NDCT base diameters and heights making it difficult or even impossible for the end user/purchaser to evaluate and compare bids effectively. The problem is even more compounded when it comes to sea water circulation in NDCTs.

Unlike Induced draught cooling towers (IDCTs), NDCTs are complex in terms of thermal as well as civil designs. NDCT thermal design is not straight forward as it is with IDCTs since the draught generated is not controlled mechanically but occur due to weather phenomena involving wind speed, adiabatic lapse rate, ambient air pressure, etc. There are not many guidelines world over (except may be, for some old publications that are out of circulation) that enumerate all the steps involved in the estimation of NTU and pressure drops for the thermal design of NDCTs. One needs to refer to the many research papers and books available in public domain for understanding the technology involved. However, the technology is not easy to understand for people outside the field and hence, has evoked little interest in end users/purchasers so far.

The committee has seized the current opportunity of reviewing the IS 11504 : 2021 'Criteria for structural design of natural draft cooling towers' to address this felt need to frame certain guidelines for design and design evaluation of NDCTs.

Keeping these aspects in mind, the committee is mandated to bring out some guidelines that take reference from multiple publications and compile the thermal design process in such a way that it is easily understood by the purchaser and also designers new to the field. In the process, the complex mathematical equations and

iterative calculations have been reduced to simple linear equations (on par with IDCT design method) so that the methodology described is appreciated and uniformly followed by all the cooling tower designers and purchasers for the overall benefit of the industry and the environment in the country.

This guideline summarises the best design practices in a brief manner for easy understanding of the users. However, certain client specifications may require some additional and specific considerations to meet the guarantee parameters. Hence, it should not be construed that satisfactory tower performance and /or a good result in a performance guarantee (PG) test by a CTI ATC 105 licensed agency is sufficient, when this guideline is followed.

Though the purchasers / end users can consider the designs resulting from this guideline as a minimum requirement, designers will be required, and so are encouraged, to make additional project specific considerations as above to result in performing cooling towers for the overall benefit of the industry and also the environment.

Most of the simplified calculation method described is taken from research papers of R.F. Rish and H. Chilton. All parameters are converted from FPS system to SI system for easy understanding and to meet the requirements of IS codes.

For better understanding, solved examples for thermic design of NDCT with fresh water circulation and with sea water circulation are given in Annex B and C.

In the formulation of this standard, assistance has been derived from the following publications:

BS 4485 – 2 Water cooling towers - Part 2 Methods for performance testing, British Standards Institution

BS 4485 – 3 Water cooling towers - Part 3: Code of practice for thermal and functional design, British Standards Institution

BSEN 14705 2005 Heat exchangers method of measurement and evaluation of thermal performances of wet cooling towers, British Standards Institution

CTI ATC 105, 2022 Acceptance test code for cooling towers, Cooling Technology Institute, Houston

CTI Blue Book, Demand curves for counterflow cooling towers, Cooling Technology Institute

Cooling tower performance prediction and improvement, Volume 1, Applications Guide, Electric Power Research Institute

Design of a Natural Draught Cooling Tower by R.F. Rish

Performance of Natural Draught Water-Cooling Towers by H. Chilton

This standard also aims at satisfying some Sustainable Development Goals by United Nations, especially Goal 9 'Industry, innovation and infrastructure'.

For the purpose of deciding whether a particular requirement of this standard is complied with, the final value, observed or calculated, expressing the result of a test

or analysis, shall be rounded off in accordance with IS 2 : 2022 'Rules for rounding off numerical values (*second revision*)'. The number of significant places retained in the rounded off value should be the same as that of the specified value in this standard.

BUREAU OF INDIAN STANDARDS

DRAFT FOR COMMENTS ONLY

(Not to be reproduced without the permission of BIS or used as an Indian Standard)

Draft Indian Standard

**THERMO-HYDRAULIC DESIGN OF NATURAL DRAUGHT COUNTER FLOW
COOLING TOWERS – GUIDELINES**

ICS No. 27.060.30

Special Structures Sectional Committee,
Sectional Committee, CED 38

Last date for comments:
08/03/2023

1 SCOPE

- 1.1** This guideline covers thermo-hydraulic design aspects of natural draught counterflow cooling towers (NDCTs).
- 1.2** For guidelines on induced draught counterflow cooling towers (IDCTs), Doc: CED 38(21889) WC may be referred.

2 REFERENCES

The standard listed below contain provisions, which through reference in this text constitute provisions of this standard. At the time of publication, the editions indicated were valid. All standards are subject to revision and parties to agreement based on this standard are encouraged to investigate the possibility of applying the most recent edition of the standards indicated below:

<i>IS No.</i>	<i>Title</i>
2405 (Part 1) 1980	Specification for industrial sieves Part 1 Wire cloth sieves (<i>fourth revision</i>)
Doc: CED 38 (21889) : WC	Thermo-hydraulic design of induced draught counterflow cooling towers – Guidelines

3 TERMINOLOGY

3.1 Air Inlet – Air inlet is the open face of the NDCT between the basin kerb level and the shell bottom through which air is sucked into the tower by the natural draught.

3.2 Cold Water Channel (CWC) – Cold water channel (CWC) is an outlet from where re-cooled water flows out of the basin toward the fore bay of a pump house. The CWC will have stop log gates and debris collecting screens.

3.3 Counter Flow Cooling Tower – A counter flow cooling tower counter flow cooling tower is a device in which the interaction between water and air is at 180° in the fill packing, that is, water fall gravitationally downward and air moves upward.

3.4 Fill or The Heat Transfer Media – the ‘fill’ or the heat transfer media is the packing inside the NDCT over which hot water falls gravitationally to exchange heat with the upward draught of ambient air.

3.5 NDCT – A NDCT is a device in which the draught is induced naturally because of the difference in densities between ambient air outside the shell and the air exiting the fill packing inside the shell.

3.6 Rain Zone – Rain zone is the space between the bottom of fill and the water surface in the basin.

3.7 Shell Exit Diameter – Shell exit diameter is an important consideration that determines from what height and distance away from the cooling tower the suction into the air inlet begins and also prevents cold air inflow into the NDCT at its upper edge.

3.8 Throat Diameter – Throat diameter is the narrowest portion of the hyperboloid which is expected to be located at the highest point possible where the bottom hyperbola and the upper hyperbola meet. This highest location of the throat is required from thermal performance considerations.

3.9 Vena Contracta – *Vena contracta* is the narrowing of the air flow after it exits the fill and the point at which this phenomenon occurs above the fill will depend on entering (air inlet) and ambient air velocities.

4 SYMBOLS AND UNITS

Symbol	Description	Unit
Q_B	Base diameter (at sill)	m
A	Pond area (at sill)	m ²
H	Air inlet height	m
ϕ_{ai}	Diameter at bottom of Shell (i.e. top of air inlet)	m
ϕ_F	Mean diameter of fill	m
$\phi_{D/E}$	Diameter at top of drift eliminator	m
ϕ_{VC}	Diameter of <i>vena contracta</i>	m
ϕ_T	Diameter at throat level	m
ϕ_e	Diameter at shell exit	m
FH	Fill height	m
H_d	Draught height (measured from the midlevel of fill)	m
H_{Tower}	Total height of NDCT ($H_d + H + FH/2$)	m
KaV/L	Tower characteristic or number of transfer units (NTU)	
L/G	Liquid to gas or water to air ratio	
K	Overall unit conductance, mass transfer between sat. air at bulk water temperature and main air stream	kg/hr/m ²
a	Effective transfer surface area per unit fill volume	m ² /m ³

V	Effective fill volume to its unit area	m^3/m^2
L	Water mass flow per unit fill area	$kg/hr/m^2$
G	Dry air mass flow per unit fill area	$kg/hr/m^2$
WBT	Wet bulb temperature	$^{\circ}C$
DBT	Dry bulb temperature	$^{\circ}C$
h_1	Enthalpy of inlet (ambient) air	KCal/Kg
h_2	Enthalpy of air exiting the fill	KCal/Kg
h_a	Enthalpy of air film in contact with hot water	KCal/Kg
t_1	Hot water temperature	$^{\circ}C$
t_2	Cold water temperature	$^{\circ}C$
R	$(t_1 - t_2) = \text{Range}$	$^{\circ}C$
C_p	Specific heat of water	KCal/Kg/ $^{\circ}C$
E_v	Evaporation loss	Kg/hr
MSL	Main sea level	m
P	Ambient air pressure at any given location	Kg/ m^2
N_{VH-ai}	Number of velocity heads for air inlet	
$N_{VH-c/b}$	Number of velocity heads for fill columns & beams	
$N_{VH-RZ+Spray}$	Number of velocity heads for rain zone + spray zone	
$N_{VH-Fill}$	Number of velocity heads for fill	
N_{VH-CB}	Number of velocity heads due to columns and beams	
$N_{VH-D/E}$	Number of velocity heads for drift eliminator	
N_{VH-T}	Number of velocity heads for throat	
N_{VH}	Total number of velocity heads for the NDCT	
WL	Water loading	kG/sec/ m^2
V_{Fill}	Afflux velocity through fill	m/sec
V_{ai}	Air velocity through Inlet	m/sec
V_{RZ}	Air velocity through Rain Zone	m/sec
V_{ao}	Air velocity above Fill	m/sec
ρ_{avi}	Density of wet air in fill	Kg/ m^3
ρ_{avF}	Density of wet air in fill	Kg/ m^3
ρ_{avo}	Density of wet air at fill exit	Kg/ m^3
$Rz + Sz$	Rain zone + Spray zone height	m
Δp	Sum of pressure drops through the NDCT	Kg/ m^2
$\Delta \rho$	Difference in air densities between inlet and top of fill	Kg/ m^2
α	Merkel number	
D_c	Duty coefficient for the NDCT	
C	Performance coefficient for the NDCT	
F_{rD}	Froude number	

5 NATURAL DRAUGHT COUNTERFLOW COOLING TOWER

A counter flow cooling tower is a device in which the interaction between water and air is at 180° in the fill packing, that is, water fall gravitationally downward and air moves

upward. An NDCT (see fig. 1) is a device in which the draught is induced naturally because of the difference in densities between ambient air outside the shell and the air exiting the fill packing inside the shell.

Positions/Locations 1 through 7 marked in the following figure identify zones where air properties change during its passage through the NDCT.

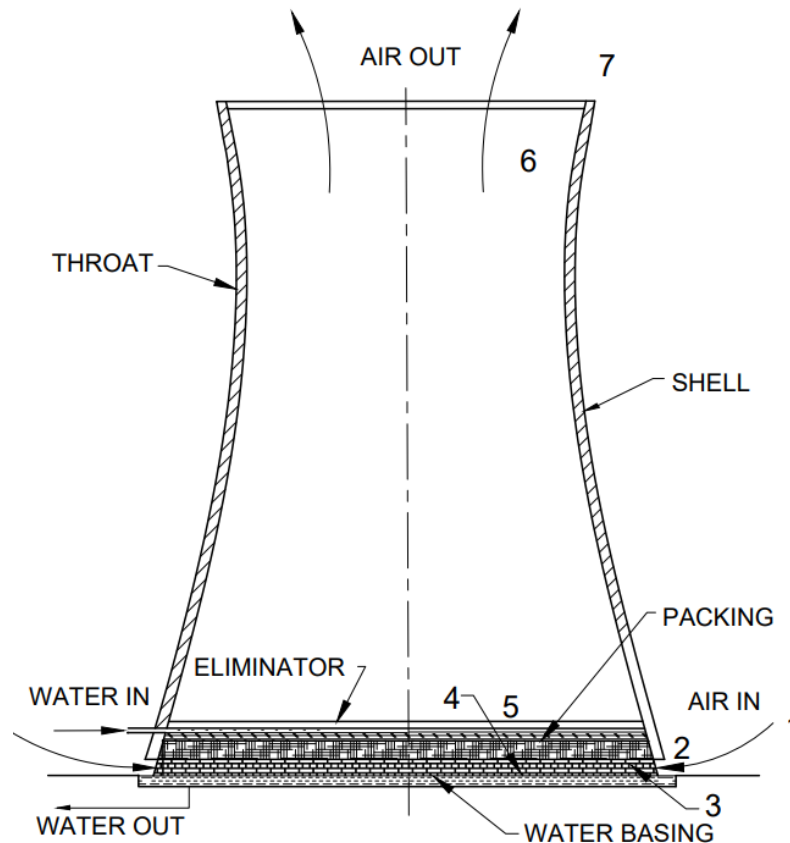

FIG. 1 NATURAL DRAUGHT COUNTERFLOW COOLING TOWER

5.1 Configuration and Components

A NDCT is of hyperboloid shape where its base diameter is larger than its throat/top diameter. The selection of the throat/top diameter involves the determination of the diameter of the *vena contracta*. Usually, the throat diameter is either the same as the diameter of the *vena contracta* or slightly less and the top diameter is either equal to or slightly more than the throat diameter depending on environmental considerations (wind speeds at top of shell) and position of the top platform (inside or outside of shell) to prevent cold air (outside air at top of shell level) entry into the shell.

The hyperboloid shape is the result of civil engineering considerations with the sole aim of optimizing material quantities. The angle of the shell at the base is usually between 14° and 21° maximum, with the optimal angle lying somewhere in between.

5.1.1 Air inlet

Air inlet is the open face of the NDCT between the basin kerb level and the shell bottom through which air is sucked into the tower by the natural draught.

5.1.1.2 Air inlets require sufficient open space all around the NDCT to ensure that unobstructed and uniform air flow into the tower all around is possible with least amount of resistance (see Fig. 2).

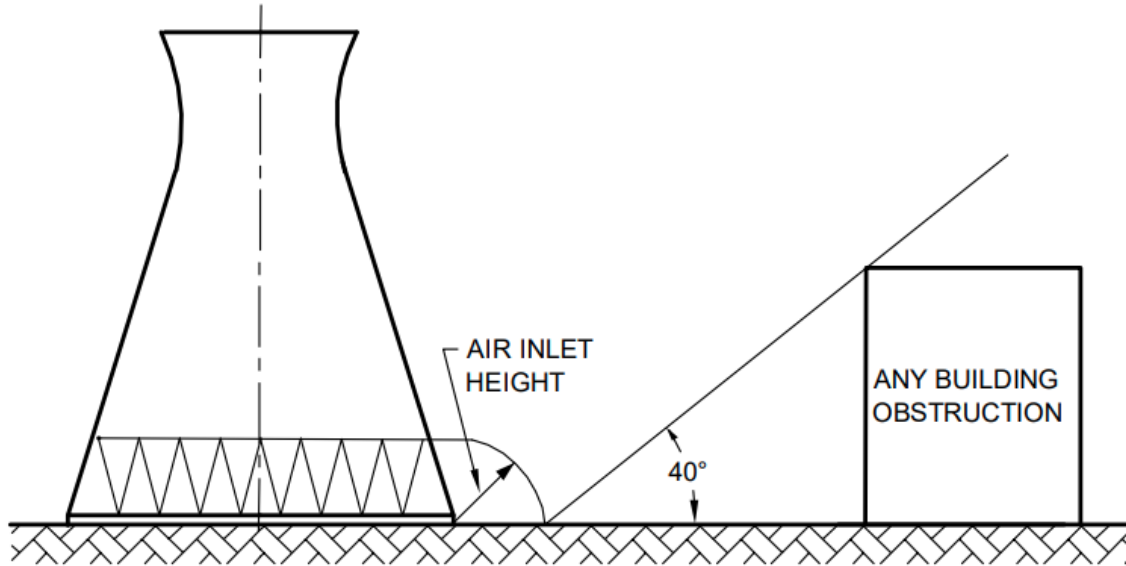

FIG. 2 MINIMUM FREE SPACE REQUIREMENT AROUND NDCT

5.1.2 *Wind Baffle*

5.1.2.1 Wind Baffle is a wall provided inside the NDCT to prevent ambient wind blowing at increased speeds (>3 m/s) from affecting the thermal performance (see fig. 3). Many wind wall configurations have been tested by researchers and usually (though other types have also been used) it is the solid wind wall that is adopted as shown below. This wind wall configuration has no pressure drop and also saves material quantities.

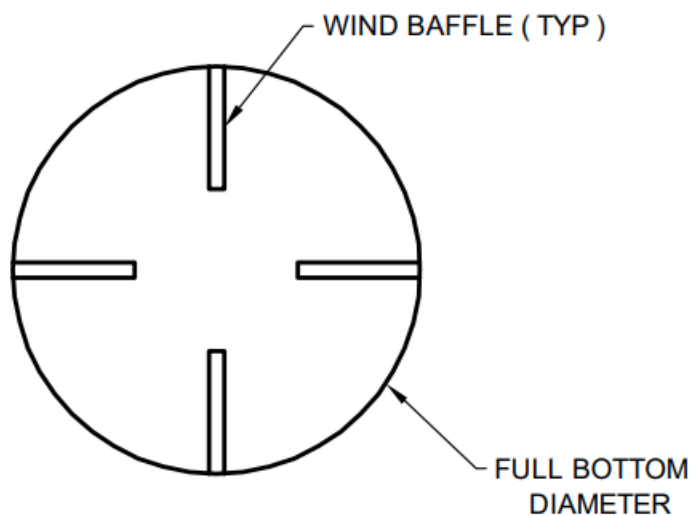

FIG. 3 WIND BAFFLE

5.1.2.2 It must be noted that even though the wind walls reduce the impact of increased wind speeds on thermal performance up to 5 m/s, the wind walls hinder/obstruct air flow at reduced wind speeds (<3 m/s) and slightly affect thermal performance. Hence, wind walls must be provided only if the ambient wind speeds are expected to be greater than 3 m/s for a greater part of the year or when there are no structures like boiler house, office buildings, etc. in proximity that in any case act as a baffle to wind flow.

5.1.3 Rain Zone

Rain Zone is the space between the bottom of fill and the water surface in the basin. Droplets of water falling through the fill are called 'rain'. The rain zone in NDCTs is large and hence, the heat transfer and pressure drop in this zone is required to be considered in the thermal design.

5.1.4 Fill or Heat Transfer Media

The 'fill' or the heat transfer media is the packing inside the NDCT over which hot water falls gravitationally to exchange heat with the upward draught of ambient air. Fills are mainly of three types – film, splash and hybrid.

5.1.4.1 Film fills are a packing which form a "film surface" over which water slides down either vertically or at an angle depending on the residence time and inter-mixing of water-air desired, also considering non-fouling characteristics required.

Film fills usually have flutes or corrugations on individual sheets that are glued or buttoned (mechanical assembly) together to form a packing or module (see fig. 5). The flute sizes vary between 10 mm and 33 mm and are selected based on intended applications like air-conditioning, animal farming, industrial heat transfer and power plant cold end systems.



FIG.4 AN ASSEMBLED CROSS-CORRUGATED FILM FILL MODULE

5.1.4.2 Splash fills come in many shapes and sizes. Some of the popular splash fills for large industrial and power plant applications in India are PP splash grid (see fig.5),

PVC Doron V bar, PVC triangular bar, RCC or PVC lath, etc. Wooden laths are still being used in some old process industries.



FIG. 5 PP SPLASH GRID

5.1.4.3 Hybrid fills are a combination of film and splash fills where the mesh structure provides surfaces for both film and droplet formation. Trickle grids (see fig. 6) are an example of hybrid fills. These fills are assembled to form modules similar to film fills, thus creating a large heat transfer surface while enhancing anti-fouling characteristics due to the mesh structure.

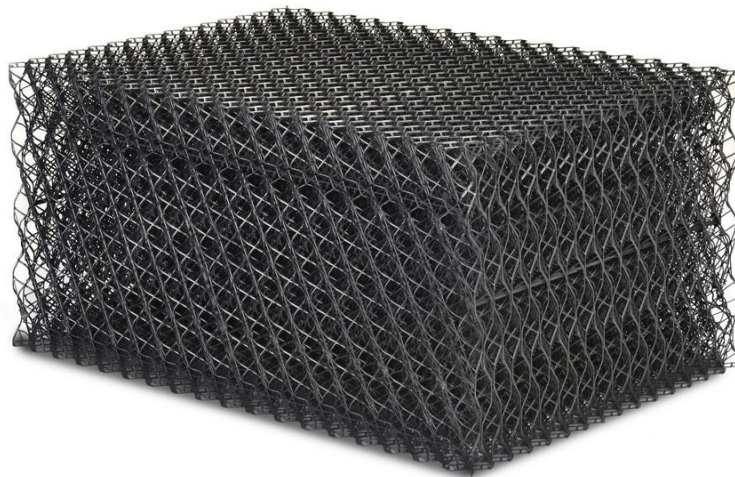

FIG. 6 HYBRID OR TRICKLE GRID FILL

5.1.5 *Distribution System*

5.1.5.1 Distribution system in a NDCT comprises of hot water channels/ducts, distribution pipes and spray nozzles. The location and sizing of the distribution system inside the NDCT depends on hydraulic optimization with consideration to flow velocities and duct/pipe sizes.

5.1.5.2 There are three options for choosing the location of the hot water channels/ducts (or more depending on proprietary custom designs) as given in fig. 7.

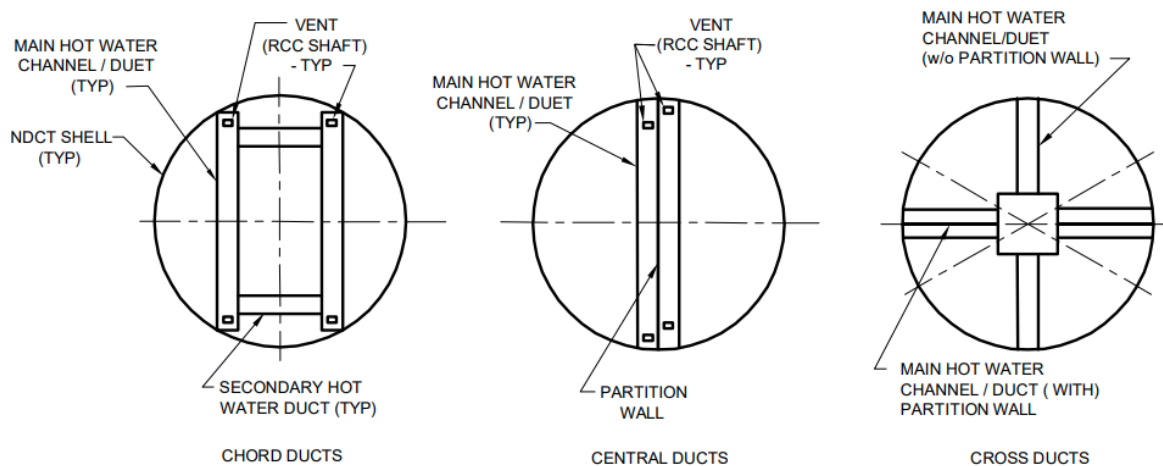

FIG. 7 HOT WATER CHENNALES/DUCTS

5.1.5.3 It is preferable that the riser pipe does not deliver hot water horizontally into the ducts as it affects distribution through the lateral pipes in the immediate proximity. The riser piping can either be routed through the air inlet or below the cold water basin to connect to the hot water ducts from the bottom to discharge water vertically. This helps in uniform distribution of water everywhere in the hot water channel/duct. This is also a civil engineering requirement as large openings in shell are not allowed.

In case the riser piping is preferred to be routed through the air inlet, the area of obstruction to the air flow must be subtracted from the net air inlet area for pressure drop calculation. Also, the piping in the air inlet must be adequately protected against corrosion from water droplets in the rain zone.

5.1.5.4 Distribution pipes are embedded in the hot water channels/ducts to span across the radius of the NDCT. These pipes can be fixed either above or below the supporting beams depending on the nozzle type, size and beam layout (see fig. 8). It is preferred to fix these pipes below the beams for down spray nozzles using polystyrene saddles, if required and a suitable strapping arrangement (usually SS straps 0.75 mm thick and 12 mm wide or other, like tie rods, etc). However, the pipes are placed above beams in case of up spray nozzles (see fig. 9). The pressure rating of the distribution pipes should not be less than 0.6 N/mm².

5.1.5.5 Up spray type of nozzles were previously proprietary to GEA and were used by them in both NDCTs and IDCTs. However, of late the down spray type has become the default standard for all cooling tower contractors. Users interested in adopting the up spray system may investigate its advantages and verify its performance on their own and also identify reliable suppliers of these nozzles with testing facilities in India.

5.1.5.6 Polypropylene spray nozzles are fixed to the distribution pipes at pre-determined locations based on performance characteristics provided by the manufacturer. Fixing the pipes with down-spray nozzles below the beams will ensure

a uniform distribution of hot water spray over the fill without any obstruction from supporting beams.

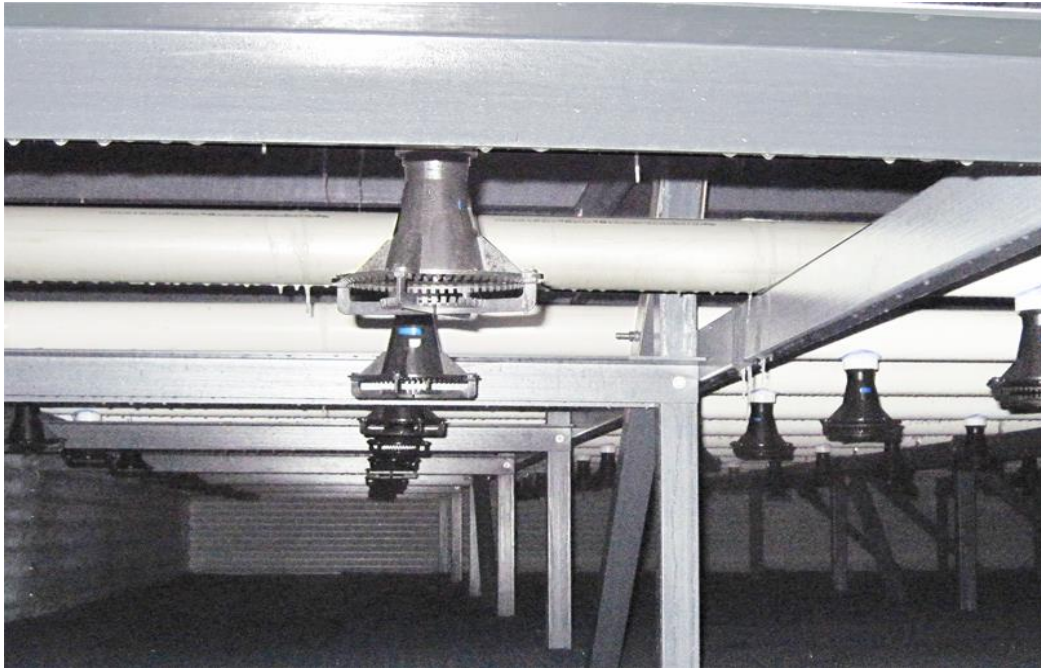

(Arrangement shown is indicative and may vary in practice)
FIG. 8 DISTRIBUTION PIPES PLACED ABOVE BEAMS



(Arrangement shown is indicative and may vary in practice)
FIG. 9 DISTRIBUTION PIPES FIXED BELOW RCC BEAMS

5.1.6 Drift Eliminators

5.1.6.1 Drift Eliminators are used in cooling towers to eliminate drift, that is, water particles/droplets being carried away by the up-draught of air. This helps in preventing loss of water and chemicals used for water treatment and also corrosion and nuisance in the NDCT vicinity.

5.1.6.2 Drift Eliminator packing is installed above the distribution level in case of pipes fixed below the RCC beams and in between the pipes in case these pipes are placed above the RCC beams.

5.1.6.3 Drift Eliminators can be of blade or cellular type (see fig. 10).

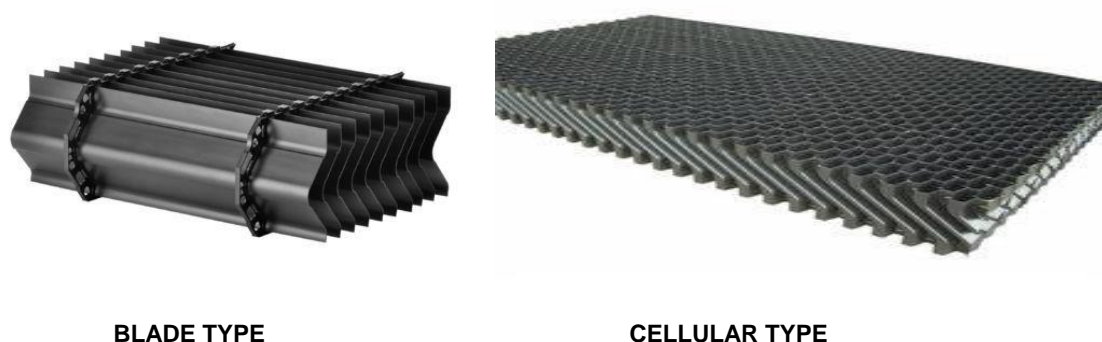

FIG. 10 DRIFT ELIMINATOR PACKING

5.1.7 *Vena Contracta*

5.1.7.1 *Vena Contracta* is the narrowing of the air flow after it exits the fill and the point at which this phenomenon occurs above the fill will depend on entering (air inlet) and ambient air velocities.

5.1.7.2 This occurs mainly because the air retains some horizontal momentum from its entry into the NDCT even after it exits the fill. As the magnitude of this horizontal momentum depends on the ratio of the air inlet diameter (bottom of shell) to the air inlet height, the diameter of the *vena contracta* is estimated using the following formula:

$$\varphi_{vc} = (0.0002 \times (\varphi_{ai}/H)^2 - 0.0183 \times (\varphi_{ai}/H) + 0.8601) \times \varphi_{ai}$$

5.1.8 *Throat diameter*

5.1.8.1 Throat diameter is the narrowest portion of the hyperboloid which is expected to be located at the highest point possible where the bottom hyperbola and the upper hyperbola meet. This highest location of the throat is required from thermal performance considerations.

5.1.8.2 The diameter of the throat should be slightly less than or equal to the diameter of the *vena contracta*, that is, $\varphi_T \leq \varphi_{vc}$ to prevent cold air entry/penetration.

5.1.9 *Shell Exit Diameter*

5.1.9.1 Shell exit diameter is an important consideration that determines from what height and distance away from the cooling tower the suction into the air inlet begins and also prevents cold air inflow into the NDCT at its upper edge (see fig. 11).

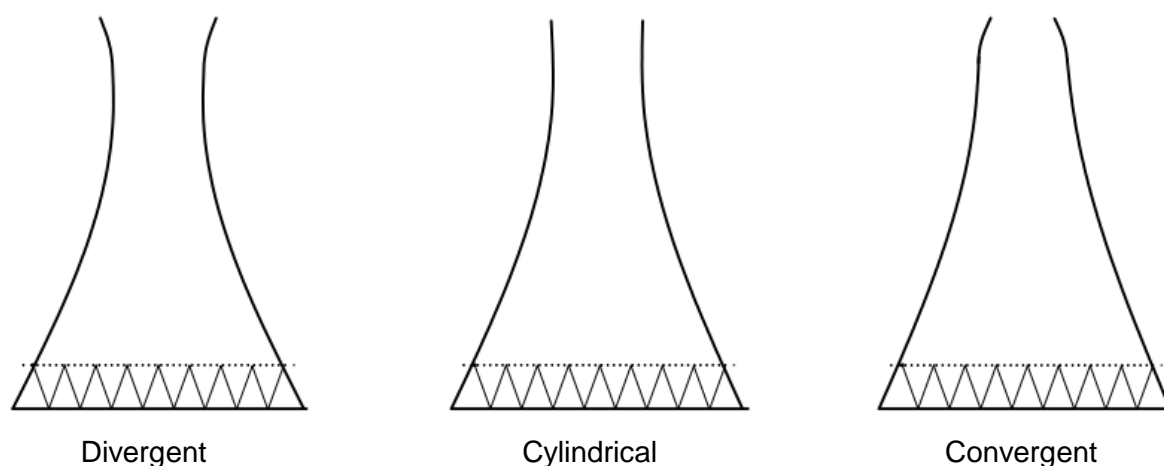

FIG. 11 DIFFERENT SHAPES OF NDCT SHELL EXIT

5.1.9.2 Froude number of a NDCT is shape dependent and indicates how well the cooling tower can perform as a system without getting affected by environmental factors within the permissible variation limits. This is an important factor that determines the exit diameter of the NDCT. The formula for the calculation of Froude number is as under:

$$F_{RD} = 2 \times (\varphi_{ai}/\varphi_e)^5 [(\varphi_{ai}/\varphi_e - 0.2 \times H_d/\varphi_{ai})^{-4} - 1]^{-1}$$

This is an iterative calculation for the exit diameter using different values of air inlet diameters at a chosen H_{Tower}/Φ_B or H_{Tower}/Φ_{ai} ratio resulting in shape specific Froude number values. The $1/F_{RD}$ value should not exceed 3 to prevent cold air entry into the NDCT at its upper edge.

It has been found by researches that the cylindrical shape of the upper edge offers the best solution against cold air entry.

5.1.10 Top platform

A platform needs to be provided at the top of the NDCT for inspection and maintenance activities. The location of this platform can be either inside or outside of the NDCT depending on the shape of the upper hyperbola desired by thermal engineers as explained above.

5.1.11 Butterfly Valve

5.1.11.1 Butterfly valves are used in the cooling tower mainly in the riser piping for open/close operation. Usually, these valves are not used in the header piping for NDCTs.

5.1.11.2 The butterfly valves in riser piping should normally be located 1200 mm or less above local ground level for ease of operation. Higher elevations may be used if operating platforms are provided.

5.1.12 Staircase and Top Platform Access

5.1.12.1 A single staircase is sufficient for access to the hot water duct level. A single cage ladder starting from the top landing of the staircase is sufficient for access to the top platform of the NDCT.

5.1.12.2 The aviation obstruction lights shall meet the recommendations of ICAO and all the requirement of Director General of Civil Aviation, India.

5.1.12.3 Since most of the NDCTs are around 180 m in height a single cage ladder would suffice. Multiple cage ladders may be required only when a second level of AOLs is required for NDCT heights exceeding 180 m.

5.1.13 Cold water channel (CWC)

Cold water channel (CWC) is an outlet from where re-cooled water flows out of the basin toward the fore bay of a pump house. The CWC will have stop log gates and debris collecting Screens.

5.1.13.1 Care must be taken in sizing the CWC that is dependent on the effective free flow area of the screen size to be installed. The free flow area (or open area) of various screen sizes must be taken from Table 1 given in IS 2405 (Part 1). This free flow area must be further reduced by 25 to 30 percent or higher depending on the number and size of support members (ISMC) used for the screen frame.

5.1.13.2 If the screen free flow area is 'X percent' and the obstruction from screen frame members is 'Y percent', the effective free flow area in percentage will be $X * (100 - Y)/100$.

5.1.13.3 It will be a good engineering practice to have the CWC width same as the required screen widths (with required wall thicknesses in between for mounting the frames) calculated as above considering the flow velocity specified across the screen (usually 0.7 m/s to 1 m/s).

5.2 Heat Transfer Process

5.2.1 Heat Transfer Process in a cooling tower involves mainly the evaporation of a small quantity of water from a large circulating flow to cool it from a given hot water temperature to a specific cold water temperature (see fig. 12). The difference between the hot and cold water temperatures is called the 'range'.

5.2.2 Since the evaporation of water occurs due to its contact with a draught of air, the cooling process is limited by the WBT of ambient air. And the driving force for this cooling process is the enthalpy difference between the air film in contact with water surface and the bulk air moving through the tower.

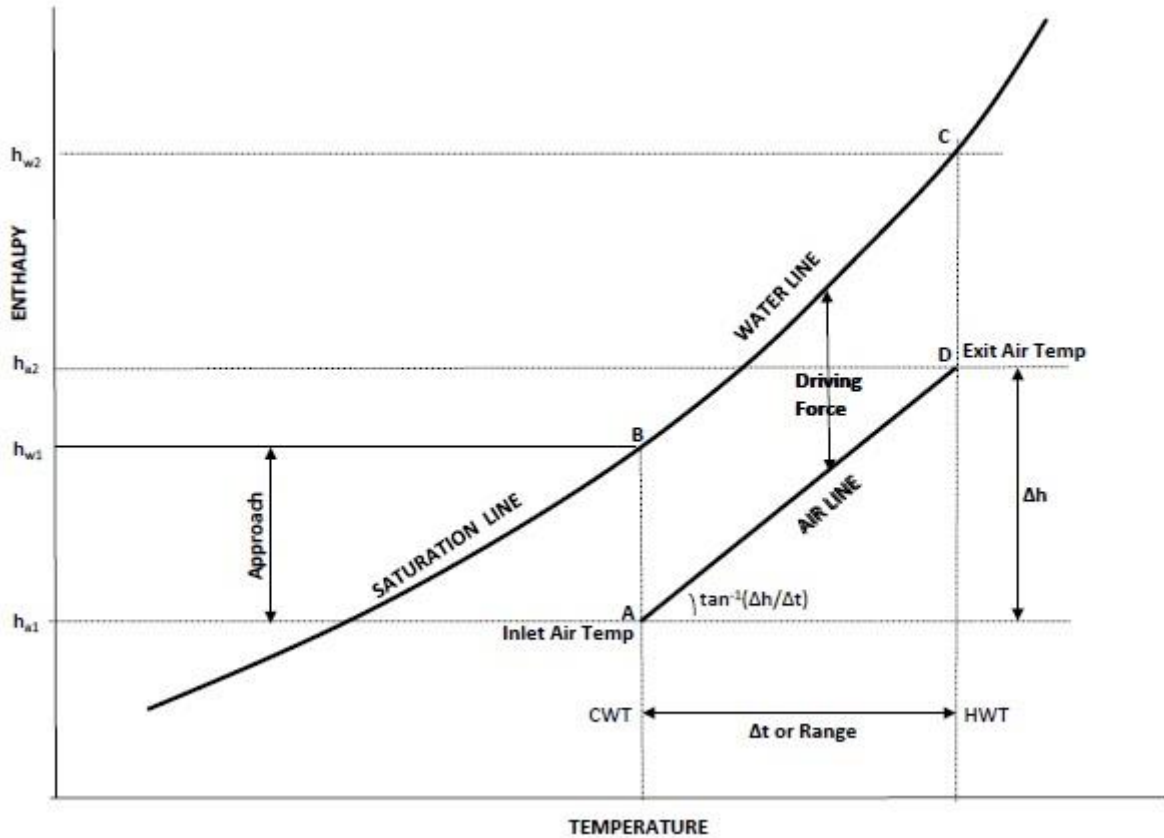

FIG. 12 HEAT TRANSFER DIAGRAM

5.2.3 Many texts and references are available to study the derivation of heat and mass transfer equation of the cooling tower, which is as below:

$$KaV/L = \int_{t_2}^{t_1} dT/(hw - ha)$$

5.2.4 Chebychev method given in CTI Blue Book and BS 4485 must be used to solve for demand KaV/L using the duty parameters specified.

5.2.5 The value of KaV/L or the NTU is an indication of the difficulty of the cooling duty drawn in the form of 'Demand Curves'. Whereas the L/G ratio of fill is taken from the intersection of the specific demand curve with the fill characteristic curve generated for a specific fill type, height and spacing or flute size (see fig. 13).

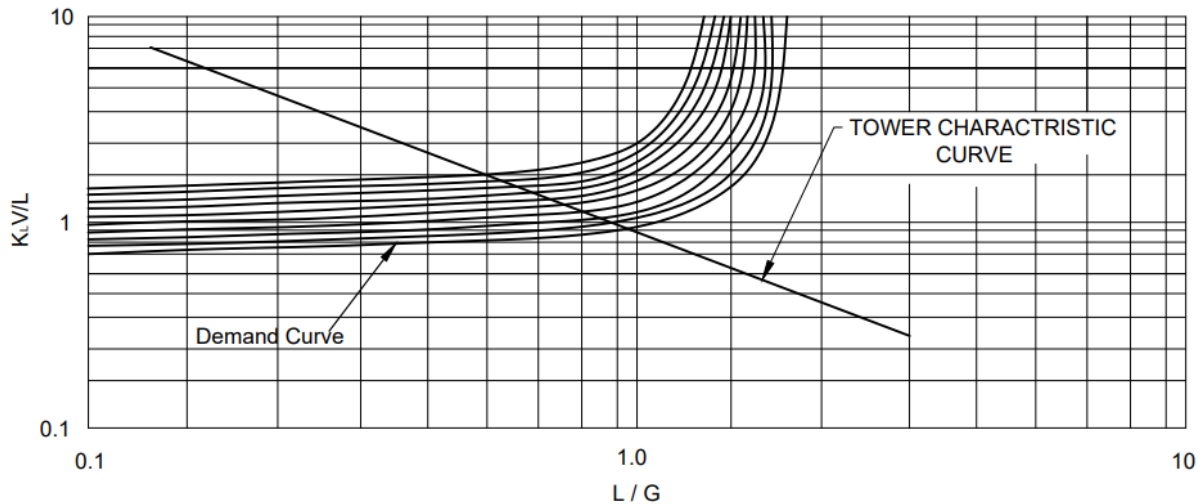

FIG. 13 TOWER DEMAND AND CHARACTERISTIC CURVE

5.2.6 However, unlike IDCTs that rain zone in NDCTs is quite large and effects a significant KaV/L gain and pressure drop that needs to be considered in thermal design. Hence, the KaV/L gain in the rain zone must be added to the KaV/L generated by the Fill.

Hence,

$$(KaV/L)_{\text{Tower}} = (KaV/L)_{\text{rain}} + (KaV/L)_{\text{Fill}}$$

The design L/G for the tower will be at a point where the combined KaV/L from fill and rain zone meet the demand KaV/L . Once the design L/G is established for the design of the NDCT, the heat balance is achieved using the equation:

$$L \times C_p \times R + E_v \times C_p \times t_2 = G(h_2 - h_1)$$

5.2.7 For a given tower design the tower characteristic in terms of KaV/L demand and design L/G is given as under:

$KaV/L = C \times (L/G)^{-n}$ or $KaV/L = C \times L^{-n} \times G^m \times HWT^{-k} \times FH$ depending on the accuracy of results required.

5.3 Specifying Thermal Design Duty

5.3.1 Specifying Wet-Bulb Temperature & Relative Humidity

Specifying the thermal design duty involves providing the parameters required for the design of the cooling tower. The duty parameters to be specified are as under:

- a) Circulating water flow rate (Kg/hr)
- b) Hot water temperature (°C)
- c) Cold water temperature (°C)
- d) Ambient WBT (°C)
- e) Relative humidity (in percentage)
- f) Site altitude (above msl)

- g) Salinity of circulating water (in case of sea water)
- h) Elevation of basin kerb above ground level
- j) Available pumping head above ground level or normal water level

5.3.1.2 Care must be taken in specifying the pumping head as splash fills require a higher pump head than film fills because of the higher fill heights involved. Insufficient pumping heads will result in poorly performing cooling towers because such designs will result in non-uniform air flows through the NDCT.

5.3.1.3 Specifying the design ambient WBT and relative humidity (RH) requires a statistical analysis of the hourly meteorological data for at least a five consecutive year period for the project site (taken from the nearest India Meteorological Department from the project site if it is an expansion project). The analysis should include WBT and coincidental DBR or RH for the same hour for the period under consideration.

5.3.1.4 The design ambient WBT and coincidental DBT or RH shall be selected in such a way that it is not exceeded by more than 5 percent of the period under consideration in a year (usually April to September).

5.3.2 Effect of Altitude on Thermal Design

5.3.2.1 The effect of altitude on thermal design must be considered only when the site elevation above MSL exceeds 300 m (see fig. 14).

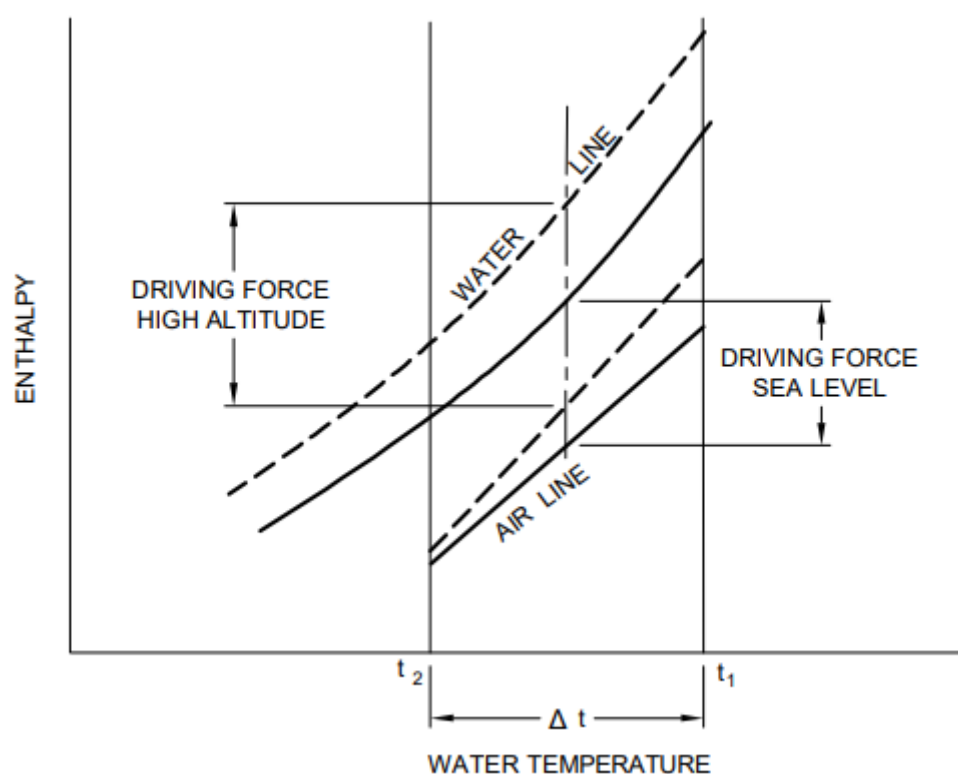

FIG. 14 EFFECT OF ALTITUDE ON DRIVING FORCE

5.3.2.2 The available driving force increases slightly with increasing altitudes (significant only beyond 300 m) resulting in smaller dimensions of NDCT.

5.3.3 Effect of Salinity on Thermal Design

5.3.3.1 Salinity reduces the vapour pressure and specific heat capacity and increases the density of sea water compared to pure or fresh water (see fig. 15).

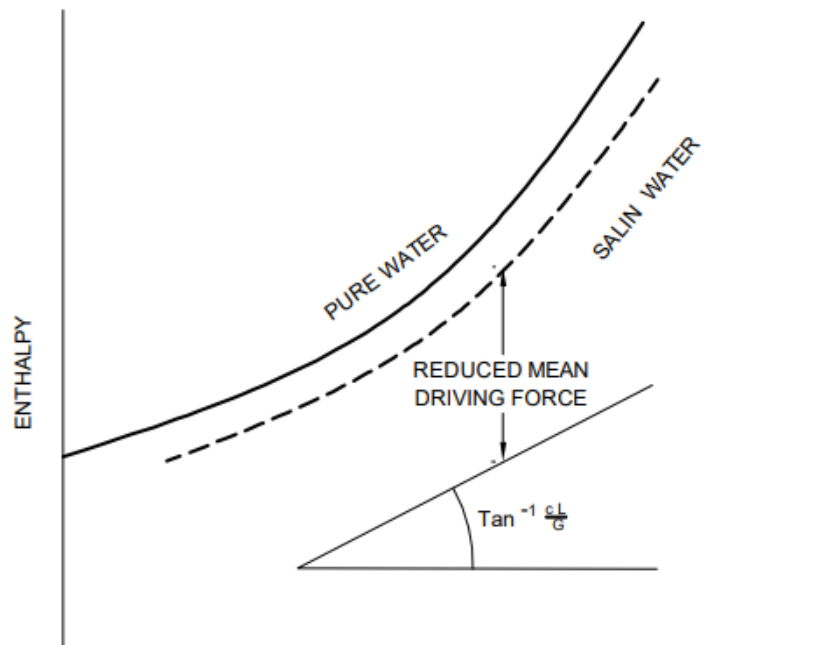

FIG. 15 EFFECT OF SALINITY ON DRIVING FORCE

5.3.3.2 On the water side, in effect the increase in density of sea water is offset by the reduction in its specific heat capacity. Hence, these effects must be ignored in thermal design. However, since the heat transfer is effected through the saturated vapour, which has a reduced pressure due to salinity, the resulting enthalpy is also reduced thereby, reducing the available driving force, which must be accounted for in thermal design.

5.3.4 Specifying a Fill for Thermal Design

5.3.4.1 Specifying a fill for thermal design involves consideration of the circulating water quality. Film fills are sensitive to water quality whereas splash fills work well with slightly poor water quality provided, there is no biological growth and excessive suspended matter (refer Table 1).

Table 1 Water Quality Parameters for Fills
(Clause 5.3.4.1)

Sl. No.	Parameter	Limits for Film Fills	Limits for Splash Fills
(1)	(2)	(3)	(4)
i)	pH	7.5 to 8.5	7.5 to 8.5
ii)	Total Suspended Solids	<60 ppm for 12 mm flute size <120 ppm for 19 mm flute size <150 ppm for low fouling models <200 ppm for 27 to 33 mm flute sizes <300 ppm for cross fluted hybrid fills <500 ppm for straight fluted hybrid fills	<1000 ppm in general for all splash fills. However, performance may be affected due to bio-growth on splash fill surfaces
iii)	Total Dissolved Solids	<2000 ppm (<5000 during operation and PG Test)	<61000 ppm However, scaling can be a problem for certain types of splash fills with slots on surface.
iv)	Total Hardness as Ca CO ₃	<150 ppm	-
v)	Oil	<10 ppm. Higher oil content will promote bio-growth and affect evaporation and heat transfer.	

5.3.4.2 Specific water quality requirements may be obtained from fill manufacturers based on their field performance data. In most of the cases the major source of fouling is biological growth and suspended matter. Oxidising biocides are the most effective bio-control agents and hence, must be used depending on water quality analysis.

5.3.4.3 It must be noted that fill selection is a compromise between thermal efficiency and fouling characteristics and hence, must be considered carefully in consultation with fill manufacturers and cooling tower designers.

5.4 Thermal Design Method

5.4.1 The thermal design of a NDCT involves the following steps:

- Establishing design KaV/L and L/G values from fill and rain zones
- Establishing pressure drops through various zones inside the NDCT
- Using the draught equation to establish the draught height of the NDCT

5.4.1.1 The establishing of the design L/G involves a few iterations as the demand KaV/L from the specified thermal duty (range, approach and WBT) is met by the individual NTUs generated by the fill and the rain zone. These iterations can easily be performed in an excel sheet.

5.4.1.2 Once the design L/G is established the pressure drops through various sections inside the NDCT can be calculated.

5.4.1.3 Once the pressure drops are calculated, the draught height of the NDCT can be established using the following equation(s):

5.4.1.4 Detailed Draught Equation

$$(P_1 - P_7) - (P_1 - P_{34}) - (P_{34} - P_6) - (P_6 - P_7) \\ = (N_{VH-ai} + N_{VH-C/B}) \times \rho_{avi} \times V_{ai}^2 / 2 + N_{VH-RZ} \times \rho_{avi} \times V_{ai}^2 / 2 + N_{VH-Fill} \\ \times \rho_{avF} V_{Fill}^2 / 2 + (N_{VH-V/DS} + N_{VH-DE} + N_{VH-T}) \times \rho_{avo} \times V_{ao}^2 / 2$$

P_1 is the ambient air pressure at ground level, P_3 through P_6 are the air pressures at various locations inside the NDCT (refer fig. 1) and P_7 is the ambient air pressure outside the NDCT near the top edge. The units on both sides will be N/m².

5.4.1.5 Simplified Draught Equation

$$H_d = \Delta p / \Delta \rho = [(N_{VH-ai} + N_{VH-C/B} + N_{VH-RZ} + N_{VH-Fill} + N_{VH-V/DS} + N_{VH-DE} \\ + N_{VH-T}) \times \rho_{avF} \times V_{Fill}^2 / 2g] / \Delta \rho$$

The equation for Δp used above applies when the number of velocity heads are referred to the fill diameter in the calculations.

5.4.1.6 The detailed draught equation requires a large program to determine the Φ_B and H_d values, whereas the simplified draught equation requires fewer steps to arrive at the NDCT sizing. As this guideline is prepared with a view to simplify the NDCT design process so that it is understood by purchasers and beginners, the simplified draught equation will be adopted here for further explanation of design steps involved.

5.4.1.7 Further, the details provided in this guideline generally apply to the design of uniform and non-uniform air-water distribution in NDCTs. However, the method of calculations presented apply specifically to uniform air-water distribution in NDCTs.

5.4.1.8 When a hot water distribution system is designed in such a way to deliver a constant flow through each of the nozzles, it is assumed that the air and water loading is uniform over the entire fill area. However, in actual practice the air flow through the fill will vary across its diameter because of the resistance offered by the rain zone below fill. And because of this phenomenon the L/G varies across the diameter and as a consequence the exit air temperature too. The average L/G and exit air temperature considered in design is a result of the assumption that these variations are minimal and do not affect the results of the mathematical formulations resulting in simplified calculations.

5.4.1.9 In contrast, a non-uniform air-water distribution system in a NDCT is designed in such a way that the air loading through the fill and the nozzle discharges over the fill are not uniform but vary across the fill diameter. The assumption here is that the air flow through the fill reduces as it moves toward the centre of the NDCT because of resistance from the rain zone. Accordingly, the hot water distribution system is

designed in such a way to result in a proportionate water loading across the fill diameter so that a uniform L/G and a consequent exit air temperature are expected to be possible. To achieve this designers adopt different fill types, heights and spacing in different radii across the fill diameter along with varying nozzle sizes to achieve a proportionate water loading. Because of the non-uniformity involved, there are no definite mathematical formulations to determine the resulting L/G and exit air temperature in each of the segments or radii but only numerical calculations involving multiple iterations to establish design values. Hence, users are advised caution while trying to adopt the non-uniform system of design and to explore available literature in this regard and/or verify existing references for performance and conduct own research for further understanding either through institutional or academic tie-ups.

5.4.2 NTU from Fill

NTU from fill is estimated using the performance characteristics from the manufacturer's published data. However, such performance characteristic data for some of the established fills that are commonly used in the industry is given below.

a) *19 mm Cross Fluted Film Fill (C.10.19 of Munters)*

$$KaV/L = 1.864 \times (L/G)^{-0.8621} \times (3.28 \times FH)^{0.8764} \times (196.8 \times V_{Fill})^{-0.1902}$$

b) *27 mm Cross Fluted Film Fill (C.10.27 of Munters)*

$$KaV/L = 0.57 \times (L/G)^{-0.7227} \times (3.28 \times FH)^{0.6706} \times (196.8 \times V_{Fill})^{-0.02745}$$

c) *MC 75 Cross Fluted Packing (19 mm of Marley)*

$$KaV/L = 1.035 \times (L/G)^{-0.781} \times (3.28 \times FH)^{0.584}$$

d) *Splash Grid – 200 mm spacing (Hamon Grid)*

$$KaV/L = 0.71 \times (L/G)^{-0.42} \times FH^{0.5}$$

5.4.3 NTU from the Rain Zone

NTU from the rain zone can be estimated using the following equation, if no other data is available:

$$(KaV/L)_{rain} = 0.016072 \times \text{Rain Height} \times (L/G)^{-0.5}$$

where,

Rain Height = Air Inlet Height (H)

5.4.4 NTU from Nozzle Spray

Even though a small KaV/L gain occurs in the spray zone when the tower is new, it is soon lost within the first 2 to 3 years as fouling of the system begins. As the tower is no longer new after commissioning, this small gain should be ignored for the sake of conservatism that is much needed in the design of cooling towers. However, if the

project specific tender specifications have no restrictions on this aspect and permits this gain in the spray zone, designers may consider the same in their thermal designs provided they have nozzle specific performance data in terms of droplet size distribution and the associated KaV/L contribution established in a test rig.

5.4.5 Pressure Drops

Pressure drop estimation requires feedback from field erected cooling towers to assess accuracy of theoretical data. The pressure drops calculations are presented in Annex A.

5.5 Design Optimization

Design optimization involves several checks requiring multiple thermal design runs before arriving at the best solution to achieve guaranteed performance.

Designs should be run with different fill heights and spacing for the chosen/specified fill type to arrive at the most economical solution. Each of the design runs will result in a different Φ_B for a given H_{Total}/Φ_B ratio. It must be ensured that Φ_{ai}/H ratio does not exceed 14 ($\Phi_{ai}/H \leq 14$) for each of the design runs to ensure that excessive pressure drops through air inlet do not occur and distort the air distribution through the tower and affect thermal performance. Generally, the smaller this ratio the better the performance.

The Φ_{ai}/H ratio also affects the $1/FrD$ value, which should always be less than 3 for the NDCT to perform as expected.

5.5.1 Water Wall-Bypass

Water wall-bypass can be as high as 1 to 5% in large field erected cooling towers. A water wall-bypass of about 3% (for properly erected fill with good workmanship) must be considered for all splash fill designs as this phenomenon occurs invariably at all junctions with RCC members and cell walls. This consideration can be in terms of increase in design circulating water flow by 3%. Some bypass is bound to occur in film fill towers too, but to a much lesser extent and can be limited to about 2% of circulating water flow.

5.5.2 Cooling towers with fill packing extending downward into the air inlet should not be opted for as the performance of the portion of the fill in the air inlet gets halved and affects overall thermal performance. Such configurations with just one or two layers of splash fill extending into the air inlet should be considered only when the available pumping head is an insurmountable issue and adequate de-rating of fill performance is considered.

NDCTs with fill packing completely above the air inlet are found to be performing as per design in field experiments.

5.5.3 Of late, it has become a practice to specify splash fills for all cooling tower designs irrespective of whether the application involves sea water, brackish water or even fresh water. The pumping head required for a splash fill tower is between 2 and

4 mWC more than that with a film fill. This is a large increase in pumping energy resulting not only in increased operating costs but also increased carbon emissions. Hybrid fills may be considered in such cases as the height required for these fills will be comparable with that of film fills.

5.5.4 In most of the cases involving fresh or slightly brackish water applications, it may be possible to use film fills even with a necessity to replace fills once in 7 to 8 years because of fouling/scaling as the replacement costs will still be economical compared to the increase in energy costs with splash fill. A basic water treatment program will be required for both film and splash fill applications because the first zone that gets affected in any cooling tower because of poor water quality is the distribution system. And the condenser tubing too gets fouled at the same time with poor quality water circulation.

5.5.5 Splash fills have either been completely eliminated or on the fast decline in many parts of the world due to the following reasons:

- a) Requires higher pump head
- b) Takes longer to install
- c) Prevents easy access to fill level for maintenance of nozzles
- d) Certain types of splash fills with slotted surfaces cannot be cleaned once choked
- e) Splash fills can sag with the passage of time affecting thermal performance

5.5.6 The performance of all types of fills gets affected because of a poorly designed or performing distribution system, more so for a Splash Fill packing. Hence, the choice of fill must be made by the designer or purchaser weighing all the options as suggested.

5.5.7 Once the individual N_{VH} values (from air inlet through throat) are calculated as explained above, the total number of velocity heads for the NDCT is arrived at by summation,

$$N_{VH-Total} = N_{VH-ai} + N_{VH-Rz+Spray} + N_{VH-Fill} + N_{VH-CB} + N_{VH-D/E} + N_{VH-T}$$

We have,

$$\Delta p = N_{VH-Total} \times \rho a v_F \times V_F^2 / 2g$$

$$\Delta p = \rho_{avi} - \rho_{avo}$$

Hence, the required draught height of the NDCT will be $H_d = \Delta p / \Delta \rho$ and the required total height of the NDCT will be $H_{Total} = H_d + FH/2 + \text{Beam Depth} + H$

The above calculations can be repeated with different fill types, fill heights and spacing, air inlet heights and H_{Total} / Φ_B ratios for a techno-economic analysis of designs.

5.5.8 In Performance of Natural Draught Water-Cooling Towers has defined the Merkel number which is $\alpha = 1/(KaV/L) + L/2G$. This number is characteristic of the tower and can be used to calculate the tower performance coefficient as under:

$$C = \alpha G/L \times (N_{VH-Total})^{1/3}$$

It is seen that C is an indication of the efficiency of the fill used in design and hence, this value remains nearly constant independent of the NDCT size and varying (off-design) duty conditions.

5.5.9 The value of C is generally found to be between 3 and 4 for film fills (depending on their heat transfer surface and thermal efficiency) and 4 and 5.5 for splash fills (sometimes higher for poorly performing splash fills). Values outside this range will result in uneconomical tower designs.

5.5.10 It is also possible to design a NDCT to achieve a specific value of C (within the range) depending on the type of fill chosen. Once the value of C is determined it is possible to arrive at a combination of NDCT dimensions in terms of Φ_B and H_{Total} using a parameter called duty coefficient (D_c). This coefficient is generally not used in thermic designs these days.

And the duty coefficient is related to the performance coefficient in terms of the pond area at sill and height of the NDCT as under:

$$D_c = A \times \sqrt{H_{Total}/(C \times \sqrt{C})}$$

Many combinations of Φ_B and H_{Total} are possible for different H_{Total}/Φ_B ratios for a given fill configuration and pumping head limits.

5.6 Hydraulic Design

Hydraulic design involves sizing of the hot water header piping, riser piping, hot water channel/duct and distribution piping and the associated pressure drops.

5.6.1 Hot Water Piping

The header and the riser piping must be sized for a velocity of 2 m/s or less as per industry practice to optimize costs. The number of TEEs, Bends and reducers must be as few as possible to reduce pressure drops in the circuit.

5.6.2 Hot Water Channel

Since the distribution system is of gravity type in cooling towers, the hot water channel/duct is open to atmosphere. This channel must be sized for a velocity not between 1 and 1.45 m/s (<1.5 m/s).

5.6.3 Distribution Pipe Sizing

5.6.3.1 The distribution pipes embedded in the hot water channel must be sized for velocities not greater than 1 to 1.15 m/s. As the length of these pipes can be very long (>30 m) in NDCTs, reducers to change to smaller pipe diameters after a certain distance, based on residual flow volume can be adopted.

5.6.3.2 The water head above the distribution piping should generally not exceed 1.15 m as the down spray nozzles are of gravity flow and hence, cannot take excess head.

5.6.4 *Spray Nozzle Selection*

Down spray nozzles that work efficiently with water head requirements between 0.5 to 0.9 m must be opted for. Up-spray nozzles, if opted for may be selected suitably based on manufacturer's recommendations.

All nozzle selections shall be made using manufacturer's nozzle curves that present performance in terms of water head, spray zone height and nozzle discharge diameters.

5.7 Tower Performance

5.7.1 Tower performance is critical in all plants, especially in power plants where revenues and carbon emissions are directly related to the heat rate that the plant can achieve. However, the cooling tower in a power plant is part of the "cold end system" that includes the condenser too.

5.7.2 As power plant engineers perform design optimization studies on the cold end system considering sizing and performance of both cooling tower and condenser, it automatically follows that the operation and maintenance of cooling tower or the condenser cannot be looked at in isolation. This is because any performance related issues with the cooling tower will affect the performance of the condenser and vice versa.

5.7.3 Any choking/fouling/scaling of fill or distribution system in the cooling tower is an indication of a similar occurrence in the condenser tubing as well. Both systems must be cleaned at the same time to ensure that performance of one end does not deteriorate because of neglect of the other.

5.7.4 Similarly, power plant engineers must be conscious about all such operational parameters that affect condenser pressure, which in turn affects cooling tower performance. For example, high energy drains to the condenser (from boiler, turbine cycle drains, etc), recirculation lines, attemperation lines, heater bypass lines, heater drains, etc, must not be left open as these badly affect the condenser pressure and also result in large heat losses. This is especially critical during the PG testing of cooling towers as the performance will be under reported even if the towers are performing well.

5.7.5 Most often the cooling tower contractors are blamed for performance related issues of the cold end system. However, it should be the responsibility of the power plant operator also to investigate contributing causes in the power plant as above. In addition the operator should also investigate the condenser itself for the following:

- a) Vacuum pump performance

- b) Air ingress into the condenser (parting plane bolting, strainer bolting, all flange connections bolting, glands, etc)
- c) Condenser tube fouling/scaling
- d) CW water flow rate

Without investigating and correcting the above parameters, insisting on cooling tower performance ignoring the dependent parameters/conditions will not help the cause of the industry. Adequate care must be taken by plant operators to ensure that all the above and other dependent parameters are taken care of to achieve desired performance of the cooling towers.

5.7.6 Once the above aspects are adequately addressed by the plant operators and the cooling tower runs at close to design parameters, a performance guarantee test can be undertaken to establish the tower capability and deviation from guaranteed design cold water temperature, if any.

ANNEX A (Clause 5.4.5)

PRESSURE DROP CALCULATIONS

A-1 This has already been done by various cooling tower designers and many reports and technical bulletins are available for reference. It is advised that the recommendations in the subsequent sections be followed as a minimum to arrive at a reasonably accurate thermal design of NDCTs. However, the designer should feel free to improve on the recommended pressure drops based on their own research information. The pressure drop calculations presented in this guideline are based on methods suggested by R.F. Rish in his technical paper – “Design of a Natural Draught Cooling Tower”.

A-1.1 As per this method the number of velocity heads (N_{VH}) is calculated first at each of the zones in the NDCT and these individual velocity heads are added to get ($N_{VH-Total}$) the total number of velocity heads for the tower. This $N_{VH-Total}$ is then used to calculate the pressure drop through the NDCT using the mid-fill packing conditions of air density (ρ_{avF}) and velocity (V_F).

A-2 Number of velocity heads through the air inlet can be calculated using the formula given below:

$$N_{VH-ai} = 0.167 \times (\varphi_{ai}/H)^2$$

A-3 As per R.F. Rish, the rain zone and spray zone are treated together to arrive at the combined velocity heads due to all sizes of droplets. The number of velocity heads through the droplet zones (rain + spray) can be calculated using the formula,

$$N_{VH-RS+Spray} = 0.16 \times \{(R_z + S_z) \times 3.28\} \times (L/G)^{1.32} = 0.5248 \times (H + S_z) \times (L/G)^{1.32}$$

as the rain zone height (R_z) is the same as air inlet height (H).

A-4 The data on number of velocity heads is not readily available for modern day fills. Manufacturers have developed complex but reliable performance equations through laboratory testing for all types of fills in the industry. These performance equations directly result in the pressure drop values. Hence, the number of velocity heads for fill required as per R.F. Rish method can be derived from the pressure drop thus estimated as below:

$$(N_{VH-Fill} = \Delta p \times 2g / (\rho_{avF} \times V_{Fill}^2)).$$

A-5 The fill performance data presented in this guideline is taken from data provided by manufacturers and that available in public domain. All the data presented is for face velocities between 300 and 700 FPM. However, the manufacturers and research bodies like EPRI have advised that the fill performance for face velocities below 300 FPM can be determined using the same fill equations with accuracy as the performance is enhanced with reducing face velocities. Hence, the pressure drop equations for some of the popular fills used in the industry that were tested for face velocities up to 700 FPM are as under:

a) 19 mm Cross Fluted Film Fill (C.10.19 of Munters)

$$\Delta p = (C0 + C1 \times WL \times 1.47234 + C2 \times V_{Fill} \times 196.8 + C3 \times V_{Fill} \times 196.8 \times WL \times 1.47234 + C4 \times (1.47234WL)^2 + C5 \times (196.8 \times V_{Fill})^2 + C6 \times 196.8 \times V_{Fill} \times (1.47234WL)^2 + C7 \times (196.8 \times V_{Fill})^2 \times 1.47234 \times WL)(3.28 \times FH)^{0.75} \times \rho av_F / 1.12 \times 25.4 \dots \dots \dots \text{mmWC}$$

where,

- C0 = -0.00023,
- C1 = 0.0019157,
- C2 = 4.1771E-5,
- C3 = -1.1197E-5,
- C4 = -4.3422E-5,
- C5 = 1.8258E-7,
- C6 = 4.5739E-7,
- C7 = 1.93E-8

b) 27 mm Cross Fluted Film Fill (C.10.27 of Munters)

$$\Delta p = (1.47234 \times WL(C0 \times 196.8 \times V_{Fill} - C1) + C2 \times (196.8 \times V_{Fill})^2)(3.28 \times FH)^{0.7} \times \rho av_F / 1.12 \times 25.4 \dots \dots \dots \text{mmWC}$$

where,

- C0 = 9.5135E-6,
- C1 = 0.0007583,
- C2 = 1.648E-7

c) MC 75 Cross Fluted Packing (19 mm of Marley)

$$\Delta p = (4.34E - 0.8 \times (196.8 \times V_{Fill})^{2.3559} + 1.47234 \times WL \times 8.11E - 07 \times 196.8 \times V_{Fill}^{1.5403}) \times (1 + 2.83E - 01 \times 3.28 \times FH) \times \rho av_F / 1.2 \times 25.4 \dots \dots \dots \text{mmWC}$$

d) Splash Grid – 200 mm spacing (Hamon Grid)

$$\Delta p = 2.88 \times WL^{0.85} \times (WL/L/G)^{-0.6} \times FH^{1.17} \times \rho av_F / 1.22 \times V_{Fill}^2 / 2g \dots \dots \dots \text{mmWC}$$

This equation for splash grid is taken from Dr. Kruger’s book.

Users are advised to consult the respective manufacturers of the above types of fills and get the equations reaffirmed before using them in their calculations and/or computer programmes.

A-6 It has become a practice now a days for end users to specify that the fill being proposed to be a used by the contractor in their project be tested in a third party test facility to evaluate its thermal performance and compare with the existing data, if available. In case no previous data exists, the data acquired from the test rig will be used for thermal design. And in case data already exists from the past, the new data acquired from the test rig is compared and the conservative of the two will have to be

used for thermal design. This is being done by end users to prevent manipulation of fill performance data by contractors in a competitive bidding environment. Hence, the fill performance data presented in this guideline must be carefully chosen by users based on their own experience, research and specific tender conditions that require performance guarantees.

A-7 The number of velocity heads due to columns and beams inside the NDCT is suggested to be 2.3 by R.F. Rish. Hence, this number should be considered as a minimum.

A-8 The number of velocity heads through the distribution system and drift eliminator is calculated using the formula,

$$N_{VH-DE} = 4.76(\varphi_F/\varphi_{DE})^4$$

A-9The number of velocity heads through the Throat of the NDCT is calculated using the formula,

$$N_{VH-T} = 1.01(\varphi_F/\varphi_T)^4$$

ANNEX B
(Foreword)

SOLVED EXAMPLE OF A NDCT THERMIC DESIGN FOR FRESH WATER APPLICATION

S.No.	Solved Example of a NDCT Thermic Design for Fresh Water Application						
1	Desihn duty Parameters						
	Water Flow Rate (L)	73,100	m3/hr				
		321,852	gpm				
	Hot Water Temp. (T1)	40.6	°C				
	Cold Water Temp. (T2)	31.6	°C				
	Wet Bulb Temp. (t1)	26	°C				
	Relative Humidity (rh1)	47	%				
	Elevation above Main Sea Level (EMSL)	0	m				
	Available Pumping Head above Ground Level (TPH)	14.2	m (say)				
NOTE – Change in air properties may be considered in design only when EMSL is 300 m or more (Ref. BS 4485/BSEN14705)							
2	<p>The water flow rate is not increased in this solved example by the wall-bypass factor of 3% that is recommended in the guideline because most often end users refuse to specify certain design criteria and leave it to the discretion of the contractor, in which case all that is not specified in the tender but required as per design practice will get ignored in a competitive bidding environment. Hence, an appropriate decision in this regard must be taken based on end user specifications</p> <p>The above thermal duty demands a specific KaV/L value that can be made available by the Fill and the Rain Zone where heat transfer takes place. KaV/L gain in the spray zone is ignored in this example but a decision in this regard may be taken by the users as per recommendations in the guideline</p>						
	The (KaV/L) _D demand can be calculated using the Chebychev/Tchebycheff method outlined in ATC-105 or BS 4485, etc						

	The solution to the problem lies in finding out what combination of fill and rain zone heights provides the KaV/L demanded by the thermal duty. However, the problem can only be solved when the exit air temperature is known so that the design Liquid to Gas ratio L/G can be determined. Obviously, this warrants iterative calculations to arrive at the correct exit air temperature and the consequent L/G. However, it may be noted that there are several possible methods of solving this thermal problem. One such method is explained below						
3	Fill Selection for KaV/L calculation						
	Assume Marley Fill MC75 Film Fill suitable for fresh water application						
	Fill Height (FH)	1.8	m (say)				
	The performance equations of this fill presented at Clause 3.4.1 of the Guidelines are as under:						
	$(KaV/L)_{fill}$	$1.035 \times (L/G)^{-0.781} \times (3.28 \times FH)^{0.584}$					
	Therefore, $(KaV/L)_{fill}$	$1.035 \times (L/G)^{-0.781} \times (1.8 \times 3.28)^{0.584}$ =		$2.92 \times (L/G)^{-0.781}$			
	The performance equations of rain zone presented at Clause 3.4.2 of the Guidelines are as under:						
	$(KaV/L)_{rain}$	$0.0049 \times \text{Rain Height} \times (L/G)^{-0.5}$		= H1 (ft)			
	The air inlet is derived from the available pumping head as under:						
	Ground Level to Basin Sill	0.3	m				
	Main Beam Dept (MBD)	0.5	m (say)				
	Secondary Beam Depth (SBD)	0.25	m (say)				
	Fill Depth (FH)	1.8	m				
	Spray Height/Zone (SZ)	0.6	m (say)				
	Nozzle Depth (ND)	0.2	m (say)				
	Head required for Nozzle	0.85	m (say)				
	Head Loss in HW Piping + Distribution System	1	m (say)				
	Sub-total (HL)	5.5					
	Possible Air Inlet Height (H1)	8.7	m	(TPH - HL)			

	Therefore, $(KaV/L)_{rain} = 0.016072 * 8.7 * (L/G)^{-0.5}$	=	$0.14 * (L/G)^{-0.5}$					
	$(KaV/L)_A = (KaV/L)_{fill} + (KaV/L)_{rain}$			KaV/L Available from Fill + Rain Zones				
		=	$2.92 * (L/G)^{-0.781} + 0.14 * (L/G)^{-0.5}$					
	This $(KaV/L)_A$ will have to be matched with $(KaV/L)_D$ to determine the exit air temperature and the design L/G							
4	The heat balance equation of a cooling tower is $L * Cp * Range + Ev * Cp * T2 = G * \Delta h$, where							
	Ev = Evaporation Loss (kg/hr)	Ev loss can be calculated once inlet and outlet air properties are established						
	Cp = Specific Heat (kcal/kg/°C) =	1						
	$\Delta h = \text{inlet enthalpy} - \text{outlet enthalpy} =$	$(h1 - h2)$	kcal/kg					
	Range = $(T1 - T2)$	9	°C					
	G = Dry Air Flow Rate (kg/hr)							
	Solving this equation without knowing what the L/G and exit air temperature would be is a little cumbersome and requires an iterative process. The CTI ATC- 105 heat balance equation ignores the heat of evaporated water for the sake of simplifying the calculations. However, in actual practice where design performance is guaranteed, this heat from the evaporated water cannot be ignored and hence, iterative calculations are required to be carried out. Equations are readily available for the calculation of air properties in BS, ASHRAE, DIN, Kroger, etc publications. As using tables is a laborious process, equations from Kroger's book are used here for demonstration purposes. The CTI tables cannot be used for NDCT design as they do not have air properties at varying relative humidities, It may be noted that the $(KaV/L)_D$ value varies with the tables/equations from different publications because of the datum differences. However, a uniform method of calculation based on any of these specific publications in their entirety will result in more or less comparable NDCT sizing							
5	Inlet Air Properties (from Equations)							
	Design Inlet WBT (t1)	26	°C					
	Relative Humidity (rH1)	47	%					
	DBT(ta1)	35.51	°C					

	Wet-air Density (ρ_{w1})	1.13178	kg/m ³				
	Abs Humidity (x1)	0.01732	kg/kg				
	Enthalpy (h1)	19.171	kcal/kg				
6	For a conservative design, it must be assumed that the exit air is fully saturated, i.e. its RH is 100%						
	Now, assume an Exit Air Temperature of say, $((T1+T2)/2) = (40.6+31.6)/2 = 36.1$ °C for the first iteration						
	Exit Air Properties (from Equations)						
	WBT (t2) @ 100% RH	36.1	°C				
	Relative Humidity (rH2)	100	%				
	DBT(t _{a2})	36.1	°C				
	Abs Humidity (x2)	0.03918	kg/kg				
	Enthalpy (h2)	32.741	kcal/kg				
	Now rearrange the heat balance equation for L/G as under:						
	$L/G = (\Delta h - (x2 - x1) * C_p \times T2) / (C_p \times \text{Range})$						
	Substituting values, we get L/G =	1.431					
	Now, as the L/G and Exit Air Enthalpy are both known, the $KaV/L)_D$ can be calculated using the Tchebycheff method						
	(Refer ATC-105 or BS 4485 codes for a detailed description of the Tchebycheff method)						
	As per the Tchebycheff method all enthalpies are considered @ 100% RH						
Iteration No.1	Water Temperature Distribution (between T1 & T2)	Enthalpy at Water Temperature (h_w)	Enthalpy Distribution (h_a)	(h_w - h_a)	1/(h_w - h_a)		
	31.6		19.171				
	32.5	27.2355	20.4589	6.7766	0.14757		
	35.2	31.2763	24.3226	6.9538	0.14381		
	37	34.2682	26.8984	7.3698	0.13569		

	39.7	39.2660	30.7621	8.5039	0.11759		
	40.6		32.0500				
				$\Sigma 1/(h_w - h_a)$	0.54466		
	As per Tchebycheff method $(KaV/L)_D = Range/4 * \zeta(h_w - h_a) * C_p$. Therefore, $(KaV/L)_D =$			1.225			
	Now, let's check how well $(KaV/L)_A$ meets the $(KaV/L)_D$ calculated						
	We have $(KaV/L)_A = 2.92 \times (L/G)^{-0.781} + 0.14 \times (L/G)^{-0.5}$						
	Substituting L/G value, we have $(KaV/L)_A =$	2.3242					
Iteration No.2	As the $(KaV/L)_D$ and $(KaV/L)_A$ do not match, the Exit Air Temperature will have to be iterated until these two values match closely						
	Exit Air Properties						
	WBT (t2) @ 100% RH	38.88	°C				
	Relative Humidity (rH2)	100	%				
	DBT (ta2)	38.88	°C				
	Wet-air Density (ρ_{w2})	1.1017	kg/m3				
	Abs Humidity (x2)	0.04603	kg/kg				
	Enthalpy (h2)	37.680	kcal/kg				
	Substituting values, we get L/G =	1.956					
	31.6		19.171				
	32.5	27.2355	20.9311	6.3044	0.15862		
	35.2	31.2763	26.2115	5.0649	0.19744		
	37	34.2682	29.7317	4.5365	0.22043		
	39.7	39.2660	35.0121	4.2538	0.23508		
	40.6		36.7722				
				$S1/(h_w -$	0.81157		

					h _a)			
	As per Tchebycheff method $(KaV/L)_D = \text{Range}/4 * \xi(h_w-h_a) * C_p$. Therefore, $(KaV/L)_D =$				1.826			
	Now, let's check how well $(KaV/L)_A$ meets the $(KaV/L)_D$ calculated							
	We have $(KaV/L)_A = 2.92 \times (L/G) + 0.14 \times (L/G)$							
	Substituting L/G value, we have $(KaV/L)_A =$	1.829						
	The iterations will end here as $(KaV/L)_A$ closely meets the $(KaV/L)_D$ calculated at the assumed Exit Air Temperature and the air properties established in this iteration will be used for further calculations							
7	Dry Air Flow through the NDCT, $G_a =$	$L/(L/G)$						
	Therefore, $G_a =$	37377996.53	kg/hr					
	Average Wet Air Density $\rho_{wm} =$	1.1167	$(\rho_{w1}+\rho_{w2})/2$					
	Absolute Humidity in Fill Zone $x_m =$	0.03167	$(x1+x2)/2$					
	Average Wer Air Flow through Fill G_{wm} =	34531117.58	m3/hr	$G_a \times (1+x_m)/\rho_{wm}$				
		9591.98	m3/sec					
	Wet Air Flow through Air Inlet $G_{w1} =$	$G_a \times (1+x1)/\rho_{w1}$						
	Therefore, $G_{w1} =$	33597558.57	m3/hr					
		9332.655	m3/sec					
	Density difference $\Delta\rho =$	$\rho_1 - \rho_2$						
	or $\Delta\rho =$	0.030	kg/m3					

<p>At this stage the diameter of the NDCT will be required to estimate the pressure drops and use the draught equation. And as the dimensions of the NDCT are not known, we need to make an initial assumption of the base/sill diameter and the H/D ratio. The H/D ratio specified in India based on structural design considerations is between 1.2 and 1.5. The choice of H/D ratio is dependent on many considerations like design wind speed for structural design, construction costs, cost of fill, client preferences, etc. Let us assume an average H/D or H_d/D_3 (Draught Height/Fill Diameter) ratio of 1.35 for this solved example</p>							
		Iteration 1			Iteration 2		
	Assume an initial value of base/sill diameter of the NDCT, $D_1 =$	100	m		121.1	m	
	Now, it follows that the diameter at the top of air inlet $D_2 =$	$D_1 - 2 \times H_1 \times \text{TAN}(\phi)$					
	$\phi =$ shell angle at the base, say 16.7°						
	Therefore, $D_2 =$	94.78	m		115.88	m	
	The average diameter of air inlet $D_{ai} =$	$(D_1 + D_2)/2$					
		97.39	m		118.49	m	
	The ratio $D_{ai}/H_1 =$	11.19			13.62		
	The diameter of fill at midpoint or average fill diameter $D_3 =$	$D_1 - 2 \times (H_1 + FH/2 + SBD + MBD) \times \text{TAN}(\phi)$					
		93.79	m		114.89	m	
	Area at this level of fill $A_{fill} =$	6908.76	m ²		10366.98	m ²	
	Effective diameter of fill considering 10% obstructions to air flow, $A_3 =$	6217.89	m ²		9330.28	m ²	
		66894.50	ft ²		100378.87	ft ²	
	The afflux velocity through fill $V_{fill} =$	G_{wm}/A_3					

		1.54	m/s		1.03	m/s		
		303.59	FPM		202.32	FPM		
	Effective Water Loading over the fill area, WL =	L/A ₃						
		4.81	gpm/ft2		3.21	gpm/ft2		
	Diameter at the drift eliminator level D ₄ =	D ₃ - 2 x (FH/2 + SZ + ND + SBD) x TAN(φ)						
		92.62	m		113.72	m		
	Diameter of Vena Contracta D _{vc} =	(0.0002 x (D _{ai} /H1) ² - 0.0183 x (D _{ai} /H1) + 0.8601) x D _{ai}						
	Therefore, D _{vc} =	66.255	m		76.777	m		
	Diameter at the throat level D ₅ =	64.255	m (say)		74.777	m (say)		
	The total pressure drop through the NDCT is required to be calculated to solve the draught equation. Hence, the individual velocity heads N _{vh} in each of the zones will have to be calculated using equations given at clause 3.4.4 of the guideline							
	N _{VH-ai} =	0.167 x (D _{ai} /H) ²	Air Inlet					
		20.927			30.977			
	N _{VH-rz+sz} =	0.5248 x (H1 + SZ) x L/G ^{1.32}	RZ + SZ					
		11.830			11.830			
	MC75 fill pressure drop as per clause 3.4.4.3 of the guideline, Pd ₃ =	(4.34E-08 x V _{Fill} ^{2.3559} + 8.11E-07 x V _{Fill} ^{1.5403} x WL) x (1 + 2.83E-01 x FH) x ρ _w /1.2						
	(Corrected for Density)	0.079	inchWC		0.052	inchWC		
		2.018	mmWC		1.327	mmWC		
	Therefore, N _{VH-Fill} =	2						

		$pd_3 \times 2g / (\rho_{wm} \times V_{Fill}^2)$						
		14.902	Fill		22.066			
	NVH-C/B =	2.3	Columns + Beams		2.3			
	NVH-DE =	$4.76x (D3/D4)^4$						
		4.881	D/S + D/E		4.858			
	NVH-Throat =	$1.01 \times (D3/D5)^4$						
		4.585	Throat		5.628			
	Therefore, total resistance through the NDCT, NTVH =	59.425			77.660			
	The total pressure drop through the NDCT Δp =	$\frac{\rho}{2} \times N \times V_{fill}^2$						
		8.049	mmWC		4.672	mmWC		
	Using the draught equation $H_d \times \Delta \rho = \Delta p$, we get $H_d \times \Delta \rho =$	$1.35 \times D3 \times \Delta \rho$						
		3.812			4.670	kg/m2		
	The base/sill diameter of the NDCT must be iterated upon until the LHS & RHS values match closely (as in iteration 2)							
					$H_d =$	155.16	m	

	<p>It must be noted that this manual method of solving the thermic problem was possible only because the fill selected did not have velocity as a variable in its KaV/L equation. For fills with velocity as a variable, an initial assumption of diameter D₁ is to be made at the KaV/L calculation stage itself and further iterations carried out. With multiple values to guess at the initial stage, a program in excel will be necessary to solve the thermic problem quickly</p>	<p>Total height of NDCT above Sill H_T =</p>		<p>H_d + FH/2 + SBD + MBD + H1</p>			
					<p>H_T =</p>	<p>165.51</p>	<p>m</p>
					<p>Basin Dia @ Sill =</p>	<p>121.1</p>	<p>m</p>
<p>8</p>	<p>Check for Heat Balance</p>						
	<p>$L \times C_p \times \text{Range} + E_v \times C_p \times T_2 = G_a \times \Delta h$</p>						
	<p>$E_v = (x_2 - x_1) * G_a$</p>						
	<p>Therefore, E_v =</p>	<p>1073479.706</p>	<p>kg/hr</p>				
	<p>The LHS of the equation will be</p>	<p>691821958.7</p>	<p>kcal/hr</p>				
	<p>& The RHS of the equation will be</p>	<p>691821958.7</p>	<p>kcal/hr</p>				
<p>9</p>	<p>In situations where the End User/EPC Contractor wants to cross check any NDCT contractor's design received as part of a bidding process, the iterations on the Base Diameter shown at clause 7 above will not apply because the Base diameter and the NDCT Height are declared by the NDCT Contractor in his bid. In such cases the End User/EPC Contractor can directly use the Base Diameter declared by the NDCT Contractor and procedure with pressure drop calculations and draught balance. If the draught balance results in a shorter NDCT height compared to that declared by the NDCT Contractor, such designs can be further investigated and suitable corrections demanded to bring the design on par with that required/expected</p>						

ANNEX C
(Foreword)

SOLVED EXAMPLE OF A NDCT THERMIC DESIGN FOR SEA WATER APPLICATION

S.No.	Solved Example of a NDCT Thermic Design for Sea Water Application						CED 38.1
1	Design duty Parameters						
	Water Flow Rate (L)	73,100	m ³ /hr				
		321,852	gpm				
	Hot Water Temp. (T1)	40.6	°C				
	Cold Water Temp. (T2)	31.6	°C				
	Wet Bulb Temp. (t1)	26	°C				
	Relative Humidity (rh1)	47	%				
	Salt Content (in make up water)	38500	ppm				
	Elevation above Main Sea Level (EMSL)	0	m				
	Available Pumping Head above Ground Level (TPH)	14.2	m (say)				
NOTE – Change in air properties may be considered in design only when EMSL is 300 m or more (Ref. BS 4485/BSEN14705)							
2	Let's say that this sea water circulating system runs at a COC of 1.5. This means that the salinity to be considered in thermic design will be (38500 x 1.5) 57,750 ppm. The effect of this salinity in sea water is that it reduces the vapor pressure that in turn reduces the enthalpy, thus reducing the available driving force. As there are no enthalpy tables published in any code for sea water, the only way to design a NDCT for sea water application is by using equations for air properties. As mentioned in the previous example with fresh water, any set of published equations or tables for air properties from any code or standard can be used for thermic design to result in more or less identical NDCT sizing. However, it must be ensured that the data used and the method applied for calculations must be uniform throughout to get proper results						

	The thermic design method presented for sea water application is identical with that of fresh water except that the vapor pressure is corrected for salinity using the equation given at Clause 8.7.3 of BS 4485					
3	Fill Selection for KaV/L calculation					
	Even though the Marley MC75 Film Fill is not suitable for Sea Water application, let's use this fill in this solved example for Sea Water application to demonstrate how the NDCT sizing varies with the change in vapor pressure due to salinity and the consequent reduction is enthalpies. If not for this example, a splash fill should have been chosen for sea water application.					
	Fill Height (FH)	1.8	m (say)			
	The performance equatins of this fill presented at Clause 3.4.1 of the Guidelines are as under:					
	$(KaV/L)_{fill}$	$1.035 \times (L/G)^{-0.781} \times (3.28 \times FH)^{0.584}$		FH in ft		
	Therefore, $(KaV/L)_{fill}$	$1.035 \times (L/G)^{-0.781} \times (3.28 \times 1.8)^{0.584}$		$2.92 \times (L/G)^{0.781}$		
		=				
	The performance equatins of rain zone presented at Clause 3.4.2 of the Guidelines are as under:					
	$(KaV/L)_{rain}$	$0.016072 * \text{Rain Height} * (L/G)^{-0.5}$				
	The air inlet is derived from the available pumping head as under:					
	Ground Level to Basin Sill	0.3	m			
	Main Beam Dept (MBD)	0.5	m (say)			
	Secondary Beam Depth (SBD)	0.25	m (say)			
	Fill Depth (FH)	1.8	m or 6 ft			
	Spray Height/Zone (SZ)	0.6	m (say)			
	Nozzle Depth (ND)	0.2	m (say)			
	Head required for Nozzle	0.85	m (say)			
	Head Loss in HW Piping + Distribution System	1	m (say)			

	Sub-total (HL)	5.5					
	Possible Air Inlet Height (H1)	8.7	m	(TPH - HL)			
		28.536	ft				
	Therefore, $(KaV/L)_{rain} = 0.016072 * 8.7 * (L/G)^{-0.5} =$			$0.14 * (L/G)^{-0.5}$			
	$(KaV/L)_A = (KaV/L)_{fill} + (KaV/L)_{rain}$			KaV/L Available from Fill + Rain Zones			
		$= 2.92 * (L/G)^{-0.781} + 0.14 * (L/G)^{-0.5}$					
	This $(KaV/L)_A$ will have to be matched with $(KaV/L)_D$ to determine the exit air temperature and the design L/G						
4	The heat balance equation of a cooling tower is $L * Cp * Range + Ev * Cp * T2 = G * \Delta h$, where						
	Ev = Evaporation Loss (kg/hr)	Ev loss can be calculated once inlet and outlet air properties are established					
	Cp = Specific Heat (kcal/kg/°C) =	1					
	$\Delta h = \text{inlet enthalpy} - \text{outlet enthalpy} =$	$(h1 - h2)$	kcal/kg				
	Range = $(T1 - T2)$	9	°C				
	G = Dry Air Flow Rate (kg/hr)						
	Solving this equation without knowing what the L/G and exit air temperature would be is a little cumbersome and requires an iterative process. The CTI ATC-105 heat balance equation ignores the heat of evaporated water for the sake of simplifying the calculations. However, in actual practice where design performance is guaranteed, this heat from the evaporated water cannot be ignored and hence, iterative calculations are required to be carried out. Equations are readily available for the calculation of air properties in BS, ASHRAE, DIN, Kroger, etc publications. As using tables is a laborious process, equations from Kroger's book are used here for demonstration purposes. The CTI tables cannot be used for NDCT design as they do not have air properties at varying relative humidities, It may be noted that the $(KaV/L)_D$ value varies with the tables/equations from different publications because of the datum differences. However, a uniform method of calculation based on any of these specific publications in their entirety will result in more or less comparable NDCT sizing						
5	Inlet Air Properties (from						

	Equations)					
	Design Inlet WBT (t1)	26	°C			
	Relative Humidity (rH1)	47	%			
	DBT(ta1)	35.51	°C			
	Wet-air Density (ρw1)	1.13178	kg/m3			
	Abs Humidity (x1)	0.01732	kg/kg			
	Enthalpy (h1)	19.171	kcal/kg			
6	For a conservative design, it must be assumed that the exit air is fully saturated, i.e. its RH is 100%					
	Now, assume an Exit Air Temperature of say, $((T1+T2)/2) = (40.6+31.6)/2 = 36.1$ °C for the first iteration					
	Exit Air Properties (from Equations)					
	WBT (t2) @ 100% RH	36.1	°C			
	Relative Humidity (rH2)	100	%			
	DBT(ta2)	36.1	°C			
	Abs Humidity (x2)	0.03918	kg/kg			
	Enthalpy (h2)	32.741	kcal/kg			
	Now rearrange the heat balance equation for L/G as under:					
	$L/G = (\Delta h - (x2 - x1) * Cp * T2) / (Cp * \text{Range})$					
	Substituting values, we get L/G =	1.431				
	Now, as the L/G and Exit Air Enthalpy are both known, the $KaV/L)_D$ can be calculated using the Tchebycheff method					
	(Refer ATC-105 or BS 4485 codes for a detailed description of the Tchebycheff method)					
	As per the Tchebycheff method all enthalpies are considered @ 100% RH					
Iteration No.1	Water Temperature Distribution (between T1 & T2)	Enthalpy at Water Temperature	Enthalpy Distribution (ha)	(hw - ha)	1/(hw - ha)	

		(h _w)				
	31.6		19.171			
	32.5	26.8578	20.4589	6.3990	0.15628	
	35.2	30.8291	24.3226	6.5065	0.15369	
	37	33.7678	26.8984	6.8694	0.14557	
	39.7	38.6737	30.7621	7.9116	0.12640	
	40.6		32.0500			
				S1/(h _w -h _a)	0.5819	
					4	
	As per Tchebycheff method $(KaV/L)_D = Range/4 * \zeta(h_w-h_a) * Cp.$ Therefore, $(KaV/L)_D =$				1.309	
	Now, let's check how well $(KaV/L)_A$ meets the $(KaV/L)_D$ calculated					
	We have $(KaV/L)_A = 2.92 \times (L/G)^{-0.781} + 0.14 \times (L/G)^{-0.5}$					
	Substituting L/G value, we have $(KaV/L)_A =$	2.3242				
Iteration No.2	As the $(KaV/L)_D$ and $(KaV/L)_A$ do not match, the Exit Air Temperature will have to be iterated until these two values match closely					
	Exit Air Properties					
	WBT (t ₂) @ 100% RH	38.53	°C			
	Relative Humidity (rH ₂)	100	%			
	DBT(t _{a2})	38.53	°C			
	Wet-air Density (ρ _{w2})	1.1035	kg/m ³			
	Abs Humidity (x ₂)	0.04511	kg/kg			
	Enthalpy (h ₂)	37.021	kcal/kg			
	Substituting values, we get L/G =	1.886				

	Water Temperature Distribution (between T1 & T2)	Enthalpy at Water Temperature (h _w)	Enthalpy Distribution (h _w - h _a) (h _a)		1/(h _w - h _a)	
	31.6		19.171			
	32.5	26.8578	20.8682	5.9897	0.16695	
	35.2	30.8291	25.9597	4.8694	0.20536	
	37	33.7678	29.3541	4.4137	0.22657	
	39.7	38.6737	34.4456	4.2281	0.23651	
	40.6		36.1428			
				S1/(h _w - h _a)	0.83540	
	As per Tchebycheff method $(KaV/L)_D = \text{Range}/4 * \xi(h_w-h_a) * C_p$. Therefore, $(KaV/L)_D =$				1.880	
	Now, let's check how well $(KaV/L)_A$ meets the $(KaV/L)_D$ calculated					
	We have $(KaV/L)_A = 2.92 \times (L/G)^{-0.781} + 0.14 \times (L/G)^{-0.5}$					
	Substituting L/G value, we have $(KaV/L)_A =$	1.881				
	The iterations will end here as $(KaV/L)_A$ closely meets the $(KaV/L)_D$ calculated at the assumed Exit Air Temperature and the air properties established in this iteration will be used for further calculations					
7	Dry Air Flow through the NDCT, G _a =	L/(L/G)				
	Therefore, G _a =	38764214.1 8	kg/hr			
	Average Wet Air Density ρ _{wm} =	1.1176	(ρ _{w1} +ρ _{w2})/2			
	Absolute Humidity in Fill Zone x _m =	0.03121	(x ₁ +x ₂)/ 2			

	Average Wer Air Flow through Fill $G_{wm} =$	$\frac{35767137.1}{6}$	m3/hr	$G_a \times \frac{1}{(1+x_m)/\rho_{wm}}$			
		9935.32	m3/sec				
	Wet Air Flow through Air Inlet $G_{w1} =$	$G_a \times \frac{1}{(1+x_1)/\rho_{w1}}$					
	Therefore, $G_{w1} =$	$\frac{34843573.1}{6}$	m3/hr				
		9678.770	m3/sec				
	Density difference $\Delta\rho =$	$\rho_1 - \rho_2$					
	or $\Delta\rho =$	0.028	kg/m3				
<p>At this stage the diameter of the NDCT will be required to estimate the pressure drops and use the draught equation. And as the dimesions of the NDCT are not known, we need to make an initial assumption of the base/sill diameter and the H/D ratio. The H/D ratio specified in India based on structural design considerations is between 1.2 and 1.5. The choice of H/D ratio is dependent on many considerations like design wind speed for structural design, construction costs, cost of fill, client prefernces, etc. Lets us assume an average H/D or H_d/D_3 (Draught Height/Fill Diameter) ratio of 1.35 for this solved example</p>							
		Iteration 1			Iteration 2		
	Assume an initial value of base/sill diameter of the NDCT, $D_1 =$	100	m		124.45	m	
	Now, it follws that the diameter at the top of air ibnlet $D_2 =$	$D_1 - 2 \times H1 \times \text{TAN}(\phi)$					
	$\phi =$ shell angle at the base, say 16.7°						
	Therefore, $D_2 =$	94.78	m		119.23	m	
	The average diameter of air inlet $D_{ai} =$	$(D_1 + D_2)/2$					
		97.39	m		121.84	m	

	The ratio $D_{ai}/H_1 =$	11.19			14.00		
	The diameter of fill at midpoint or average fill diameter $D_3 =$	$D_1 - 2 \times (H_1 + FH/2 + SBD + MBD) \times \tan(\phi)$					
		93.79	m		118.24	m	
	Area at this level of fill $A_{fill} =$	6908.76	m ²		10980.36	m ²	
	Effective diameter of fill considering 10% obstructions to air flow, $A_3 =$	6217.89	m ²		9882.32	m ²	
		66894.50	ft ²		106318.0	ft ²	
	The afflux velocity through fill $V_{fill} =$	G_{wm}/A_3					
		1.60	m/s		1.01	m/s	
		314.46	FPM		197.86	FPM	
	Effective Water Loading over the fill area, $WL =$	L/A_3					
		4.81	gpm/ft ²		3.03	gpm/ft ²	
	Diameter at the drift eliminator level $D_4 =$	$D_3 - 2 \times (FH/2 + SZ + ND + SBD) \times \tan(\phi)$					
		92.62	m		117.07	m	
	Diameter of Vena Contracta $D_{vc} =$	$(0.0002 \times (D_{ai}/H_1)^2 - 0.0183 \times (D_{ai}/H_1) + 0.8601) \times D_{ai}$					
	Therefore, $D_{vc} =$	66.255	m		78.348	m	
	Diameter at the throat level $D_5 =$	64.255	m (say)		76.348	m	
	The total pressure drop through the NDCT is required to be calculated to solve the draught equation. Hence, the individual velocity heads N_{vh} in each of the zones will have to be calculated using equations given at clause 3.4.4 of the guideline						

	$N_{VH-ai} =$	$0.167 \times (D_{ai}/H)^2$	Air Inlet				
		20.927			32.753		
	$N_{VH-rz+sz} =$	$0.16 \times (H1 + SZ) \times L/G^{1.32}$	RZ + SZ				
		11.275	H1 & SZ in ft		11.275		
	MC75 fill pressure drop as per clause 3.4.4.3 of the guideline, $P_{d3} =$	$(4.34E-08 \times V_{Fill}^{2.3559} + 8.11E-07 \times V_{Fill}^{1.5403} \times WL) \times (1 + 2.83E-01 \times FH) \times \rho_{wm}/1.2$					
	(Corrected for Density)	0.151	inchWC		0.049	inchWC	
		3.833	mmWC		1.239	mmWC	
	Therefore, $N_{VH-Fill} =$	$P_{d3} \times 2g/(\rho_{wm} \times V_{Fill}^2)$					
		26.353	Fill		21.519		
	$N_{VH-C/B} =$	2.3	Columns + Beams		2.3		
	$N_{VH-DE} =$	$4.76 \times (D_3/D_4)^4$					
		4.881	D/S + D/E		4.856		
	$N_{VH-Throat} =$	$1.01 \times (D_3/D_5)^4$					
		4.585	Throat		5.810		
	Therefore, total resistance through the NDCT,	70.321			78.514		

	NTVH =							
	The total pressure drop through the NDCT $\Delta p =$	$\frac{\rho \times N \times V}{2 \times 2g \times w m}$ TVH fill						
		10.227	mmWC		4.521	mmWC		
	Using the draught equation $H_d \times \Delta \rho = \Delta p$, we get $H_d \times \Delta \rho =$	$1.35 \times D^3 \times \Delta \rho$						
		3.586			4.521	kg/m ²		
	The base/sill diameter of the NDCT must be iterated upon until the LHS & RHS values match closely (as in iteration 2)							
					$H_d =$	159.61	m	
	It must be noted that this manual method of solving the thermic problem was possible only because the fill selected did not have velocity as a variable in its KaV/L equation. For fills with velocity as a variable an initial assumption of diameter D_1 is to be made at the KaV/L calculation stage itself and further iterations carried out. With multiple values to guess at the initial stage, a program in excel will be necessary to solve the thermic problem quickly				Total height of NDCT above Sill H_T $= H_d + FH/2 + SBD + MBD + H_1$			
						$H_T (m) =$	169.9647	
						Basin Dia @ Sill (m) =	124.45	
8	Check for Heat Balance							
	$L \times C_p \times Range + E_v \times C_p \times T_2 = G_a \times \Delta h$							
	$E_v = (x_2 - x_1) \times G_a$							
	Therefore, $E_v =$	1077577.08	kg/hr					

		3					
	The LHS of the equation will be	691951435. 8	kcal/hr				
	& The RHS of the equation will be	691951435. 8	kcal/hr				
9	<p>In situations where the End User/EPC Contractor wants to cross check any NDCT contractor's design received as part of a bidding process, the iterations on the Base Diameter shown at clause 7 above will not apply because the Base diameter and the NDCT Height are declared by the NDCT Contractor in his bid. In such cases the End User/EPC Contractor can directly use the Base Diameter declared by the NDCT Contractor and procedure with pressure drop calculations and draught balance. If the draught balance results in a shorter NDCT height compared to that declared by the NDCT Contractor, such designs can be further investigated and suitable corrections demanded to bring the design on par with that required/expected</p>						