



भारतीय मानक ब्यूरो
(उपभोक्ता मामले, खाद्य एवं सार्वजनिक वितरण मंत्रालय, भारत सरकार)
BUREAU OF INDIAN STANDARDS
(Ministry of Consumer Affairs, Food & Public Distribution, Govt. of India)

मानक भवन, 9, बहादुर शाह ज़फर मार्ग, नई दिल्ली - 110002
Manak Bhawan, 9, Bahadur Shah Zafar Marg, New Delhi -
110002
Phones: 23230131 / 23233375 / 23239402
Website: www.bis.gov.in, www.manakonline.in

व्यापक परिचालन मसौदा

हमारा संदर्भ : सीईडी 22:5/टी-09

12 जुलाई 2023

तकनीकी समिति: अग्नि शमन विषय समिति, सीईडी 22

प्राप्तकर्ता :

1. सिविल अभियांत्रिकी विभाग परिषद, सीईडीसी के सभी सदस्य
2. अग्नि शमन विषय समिति, सीईडी 22 और इसकी उपसमितियों के सभी सदस्य
3. रुचि रखने वाले अन्य निकाय।

महोदय/ महोदया,

निम्नलिखित मानक का मसौदा संलग्न है:

प्रलेख संख्या	शीर्षक
सीईडी 22(22809)WC	साइकिल, स्केटबोर्ड, और रोलर स्केट्स के उपयोगकर्ताओं के लिए संरक्षी हेलमेट — विशिष्टि का भारतीय मानक मसौदा, [आईसीएस 13.340.20]

कृपया इस मसौदे का अवलोकन करें और अपनी सम्मतियाँ यह बताते हुए भेजे कि यह मसौदा प्रकाशित हो तो इन पर अमल करने में आपको व्यवसाय अथवा कारोबार में क्या कठिनाइयां आ सकती हैं।

सम्मतियाँ भेजने की अंतिम तिथि: 12 अगस्त 2023

सम्मति यदि कोई हो तो कृपया अधोहस्ताक्षरी को ई-मेल द्वारा ced22@bis.gov.in पर या उपरलिखित पते पर, संलग्न फॉर्मेट में भेजें। सम्मतियाँ बीआईएस ई-गवर्नेंस पोर्टल, www.manakonline.in के माध्यम से ऑनलाइन भी भेजी जा सकती हैं।

यदि कोई सम्मति प्राप्त नहीं होती है अथवा सम्मति में केवल भाषा संबंधी त्रुटि हुई तो उपरोक्त प्रालेख को यथावत अंतिम रूप दे दिया जाएगा। यदि सम्मति तकनीकी प्रकृति की हुई तो विषय समिति के अध्यक्ष के परामर्श से अथवा उनकी इच्छा पर आगे की कार्यवाही के लिए विषय समिति को भेजे जाने के बाद प्रालेख को अंतिम रूप दे दिया जाएगा।

यह प्रालेख भारतीय मानक ब्यूरो की वेबसाइट www.bis.gov.in पर भी उपलब्ध है।

धन्यवाद।

भवदीय

ह/-

अरुण कुमार एस
वैज्ञानिक ई एवं प्रमुख
सिविल अभियांत्रिकी विभाग
ई-मेल: ced22@bis.gov.in
फोन: +91-11 2323 5529

संलग्न: उपरलिखित



भारतीय मानक ब्यूरो
(उपभोक्ता मामले, खाद्य एवं सार्वजनिक वितरण मंत्रालय, भारत सरकार)
BUREAU OF INDIAN STANDARDS
(Ministry of Consumer Affairs, Food & Public Distribution, Govt. of India)

मानक भवन, 9, बहादुर शाह ज़फर मार्ग, नई दिल्ली - 110002
Manak Bhawan, 9, Bahadur Shah Zafar Marg, New Delhi -
110002
Phones: 23230131 / 2323375 / 23239402
Website: www.bis.gov.in, www.manakonline.in

WIDE CIRCULATION DRAFT

Our Reference: CED 22:5/T-09

12 July 2023

TECHNICAL COMMITTEE: FIRE FIGHTING SECTIONAL COMMITTEE, CED 22

ADDRESSED TO:

1. All Members of Civil Engineering Division Council, CEDC
2. All Members of Fire Fighting Sectional Committee, CED 22 and all its Subcommittees
3. All others interested.

Dear Sir/ Madam,

Please find enclosed the following draft:

Doc No.	Title
CED 22(22809)WC	Draft Indian Standard Protective Helmet for Users of Bicycles, Skateboard, and Roller Skates — Specification, ICS 13.340.20

Kindly examine the attached draft and forward your views stating any difficulties which you are likely to experience in your business or profession if this is finally adopted as National Standard.

Last Date for Comments: 12 August 2023

Comments if any, may please be made in the enclosed format and emailed at ced22@bis.gov.in or sent at the above address. Additionally, comments may be sent online through the BIS e-governance portal, www.manakonline.in.

In case no comments are received or comments received are of editorial nature, kindly permit us to presume your approval for the above document as finalized. However, in case comments, technical in nature are received, then it may be finalized either in consultation with the Chairman, Sectional Committee or referred to the Sectional Committee for further necessary action if so desired by the Chairman, Sectional Committee.

The document is also hosted on BIS website www.bis.gov.in.

Thanking you,

Yours faithfully,

Sd/-

Arun Kumar S

Scientist 'E' & Head

Civil Engineering Department

Email: ced22@bis.gov.in

Phone: +91-11 2323 5529

Encl: As above

FORMAT FOR SENDING COMMENTS ON THE DOCUMENT

[Please use A4 size sheet of paper only and type within fields indicated. Comments on each clause/sub-clause/table/figure, etc, be stated on a fresh row. Information/comments should include reasons for comments, technical references, and suggestions for modified wordings of the clause. **Comments through e-mail to ced22@bis.gov.in shall be appreciated.**]

Doc. No.: CED 22(22809)WC

BIS Letter Ref: CED 22:5/T-09

Title: Draft Indian Standard Protective Helmet for Users of Bicycles, Skateboard, and Roller Skates — Specification, *ICS 13.340.20*

Last date of comments: **12 August 2023**

Name of the Commentator/ Organization: _____

Clause/ Para/ Table/ Figure No. commented	Type of Comment (Technical/ Editorial/ General)	Comments/Modified Wordings	Justification of Proposed Change

NOTE- Kindly insert more rows as necessary for each clause/table, etc.

BUREAU OF INDIAN STANDARDS

DRAFT FOR COMMENTS ONLY

(Not to be reproduced without the permission of BIS or used as a Standard)

Draft Indian Standard

PROTECTIVE HELMET FOR USERS OF BICYCLES, SKATEBOARDS AND ROLLER SKATES — SPECIFICATION

ICS 13.340.20

**Fire Fighting Sectional
Committee, CED 22**

**Last Date for Comments:
12 August 2023**

FOREWORD

(Formal clauses shall be added later)

Helmet is one of the most important items of personal protective equipment used by the users of bicycle, skateboards, and roller skates for protection against the hazards connected. This standard has been framed to cover provisions of protective helmets for everyday use by the bicycle riders and for other recreational activities.

A proportion of the energy of an impact is absorbed by the helmet, thereby reducing the force of the blow sustained by the head. The structure of the helmet may be damaged in absorbing this energy and any helmet that sustains a severe blow needs to be replaced even if damage is not apparent.

Wearing a helmet cannot always prevent death or permanent disability because the level of protection it provides depends on the specifics of the accident.

It is of importance for the wearer's comfort and psychrometric performance that a helmet is ventilated. Manufacturers of helmets are urged to design their helmets to encourage a flow of air over the wearer's head.

IS 4151: 2015 'Protective helmet for two-wheeler riders — Specification (*fourth revision*)' provides the requirements for the protective helmets with or without lower face cover for everyday use by two-wheeler riders. The standard IS 4151 provides apart from others two prominent sizes of the headforms namely 500 and 520 which suits the children.

The helmets, having headform size below 500, conforming to this standard may be used as 'crash helmet' for the children particularly below the age of 4 years even while they are riding on pillion of two-wheeler, wherein speed shall not exceed 40 km/h. This standard is thus formulated to address the Gazette Notification dated 15 February 2022 issued by the Ministry of Road Transport and Highways (MoRTH) on the above subject. Considering the usability, the technical committee observed that the mass of

crash helmets which conform to this standard be as low as possible and not less than 300 grams.

Bicycle riders' helmets and helmets for users of skateboards and roller skates are fitted with a retention system to retain the helmet on the head. However, there may be a foreseeable risk that helmets of young children could become trapped and thereby cause a risk of strangulation of the child. In such cases an impact protection helmet for young children shall be used under expert guidance.

In the formulation of this standard considerable assistance was taken from the EN 1078: 2012 'Helmets for pedal cyclists and for users of skateboards and roller skates'.

This Standard contributes to the United Nations' Sustainable Development Goal 3, SDG 3: 'Good Health and Wellbeing'.

For the purpose of deciding whether a particular requirement of this standard is complied with the final value, observed or calculated, expressing the result of a test or analysis shall be rounded off in accordance with IS 2 : 2022 'Rules for rounding off numerical values (*second revised*)'. The number of significant places retained in the rounded off value should be same as that of the specified value in this standard.

BUREAU OF INDIAN STANDARDS**DRAFT FOR COMMENTS ONLY***(Not to be reproduced without the permission of BIS or used as a Standard)**Draft Indian Standard***PROTECTIVE HELMET FOR USERS OF BICYCLES, SKATEBOARDS AND
ROLLER SKATES — SPECIFICATION**

ICS 13.340.20

1 SCOPE

1.1 This standard covers the requirements regarding the material, construction, workmanship, finish, mass, and performance for helmets worn by the users of bicycles, skateboards, and roller skates.

1.2 The helmets covered in this standard can also be used when children are accompanied by adult while traveling on motorcycle at speeds not exceeding 40 km/h.

1.3 This standard covers the requirements and corresponding methods of test as follows:

- a) construction, including field of vision;
- b) shock absorbing properties;
- c) retention system properties, including chin strap and fastening devices; and
- d) marking information.

2 REFERENCES

The following standards contain provisions which, through reference in this text, constitute provisions of this standard. At the time of publication, the editions indicated were valid. All standards are subject to revision and parties to agreements based on this standard are encouraged to investigate the possibility of applying the most recent editions of the standards indicated below:

<i>IS No.</i>	<i>Title</i>
Doc No: CED 22(22809)WC	Headforms for use in the testing of protective helmets — Specification (<i>under circulation</i>)
IS 17863 (Part 1): 2022 (Part 2): 2022 (Part 3): 2022	Plastics — Methods of exposure to laboratory light sources Part 1 General guidance Part 2 Xenon-arc lamps Part 3 Fluorescent UV lamps

3 TERMINOLOGY

For the purposes of this document, the following terms and definitions apply:

3.1 Protective Helmet (Crash Helmet) — Item that is worn on the head and is designed to absorb impact energy to lessen the risk of head injury and brain damage.

3.2 Helmet Type — Category of helmets which does not differ in such essential respects as the materials or dimensions or construction of the helmet, of the retention system or of the protective padding.

3.3 Padding

3.3.1 Protective Padding — A material used to absorb impact energy.

3.3.2 Comfort Padding — A lining material provided for the wearer's comfort.

3.3.3 Sizing Padding — A lining material used to adjust the size of helmet.

3.4 Retention System — The complete assembly by means of which the helmet is maintained in position on the head including any devices for adjustment of the system or to enhance the wearer's comfort.

3.5 Chin-strap — A part of the retention system consisting of a strap that passes under the wearer's jaw to keep the helmet in position.

3.6 Basic Plane of the Human Head — A plane at the level of the external ear opening (external auditory meatus) and the lower edge of the eye sockets (orbits).

3.7 Basic Plane of a Headform — A plane relative to the headform that corresponds to the basic plane of the human head.

3.8 Reference Plane — A construction plane parallel to the basic plane of the headform at a distance from it which is a function of the size of the headform.

3.9 Test Area — Area of the helmet in which impact tests may be conducted which corresponds to the minimum protected area of the human head.

4 REQUIREMENTS

4.1 Materials

For those parts of the helmet coming into contact with the skin, the material shall be known not to undergo considerable change from contact with sweat or with compounds expected to be found in toiletries. Materials that are known to cause skin conditions shall not be used.

4.2 Construction

The typical helmet has a way of absorbing impact force and a way of keeping the helmet on the head during an accident.

The helmet should be durable and withstand handling. The helmet shall be so

designed and shaped that the parts of it (visor, rivets, ventilators, edges, fastening device and the like) are not likely to injure the user in normal use.

NOTE — Helmets should:

- a) have low weight;
- b) be ventilating;
- c) be easy to put on and take off;
- d) be usable with spectacles;
- e) not significantly interfere with the ability of the user to hear traffic noise.

4.3 Field of Vision

When tested in accordance with **5.7** there shall be no occultation in the field of vision bounded by angles as follows (see Fig. 1), see also *CED22(22809)WC*:

- a) Horizontally — *Min.* 105° from the longitudinal vertical median plane to the left- and right-hand sides;
- b) Upwards — *Min.* 25° from the reference plane;
- c) Downwards — *Min.* 45° from the basic plane. ≥

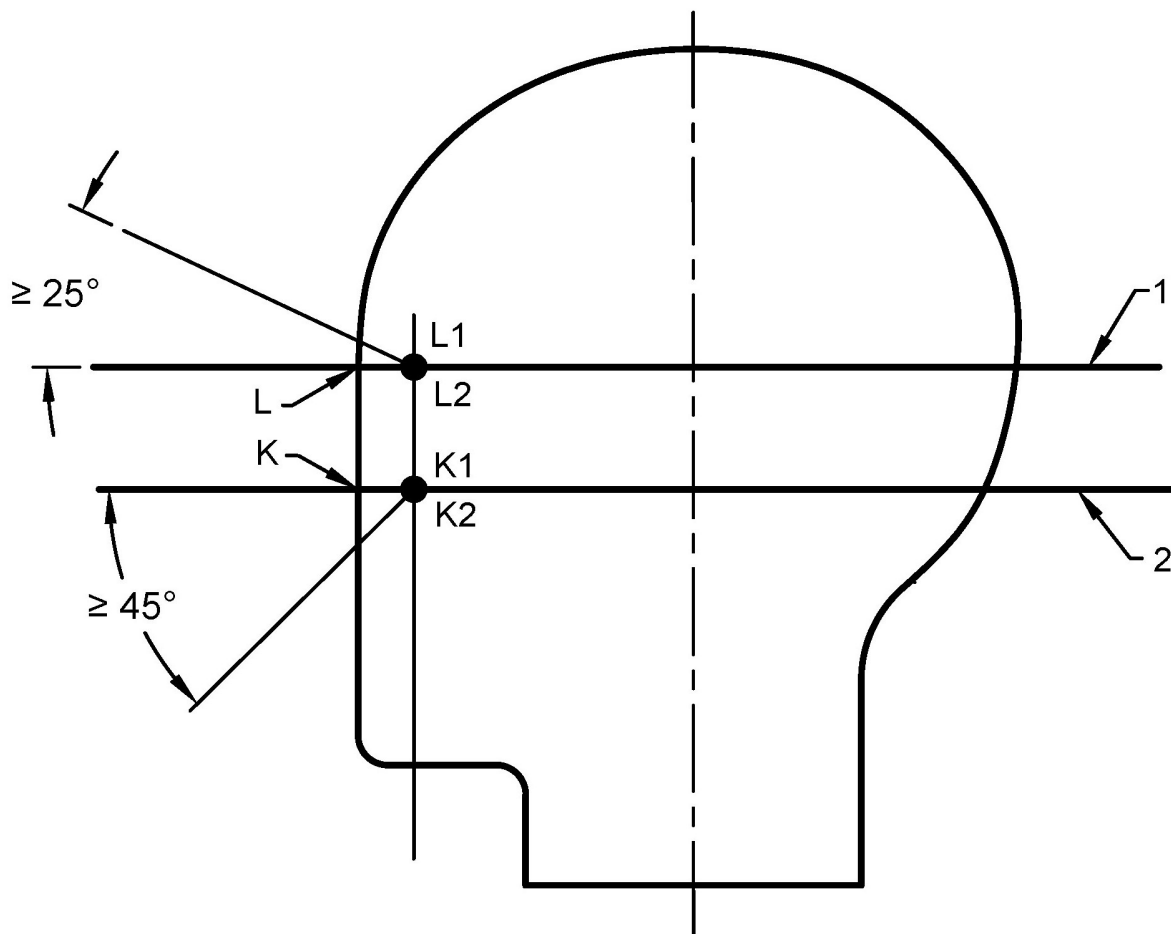

1A SECTION OF HEADFORM IN LONGITUDINAL VERTICAL PLANE

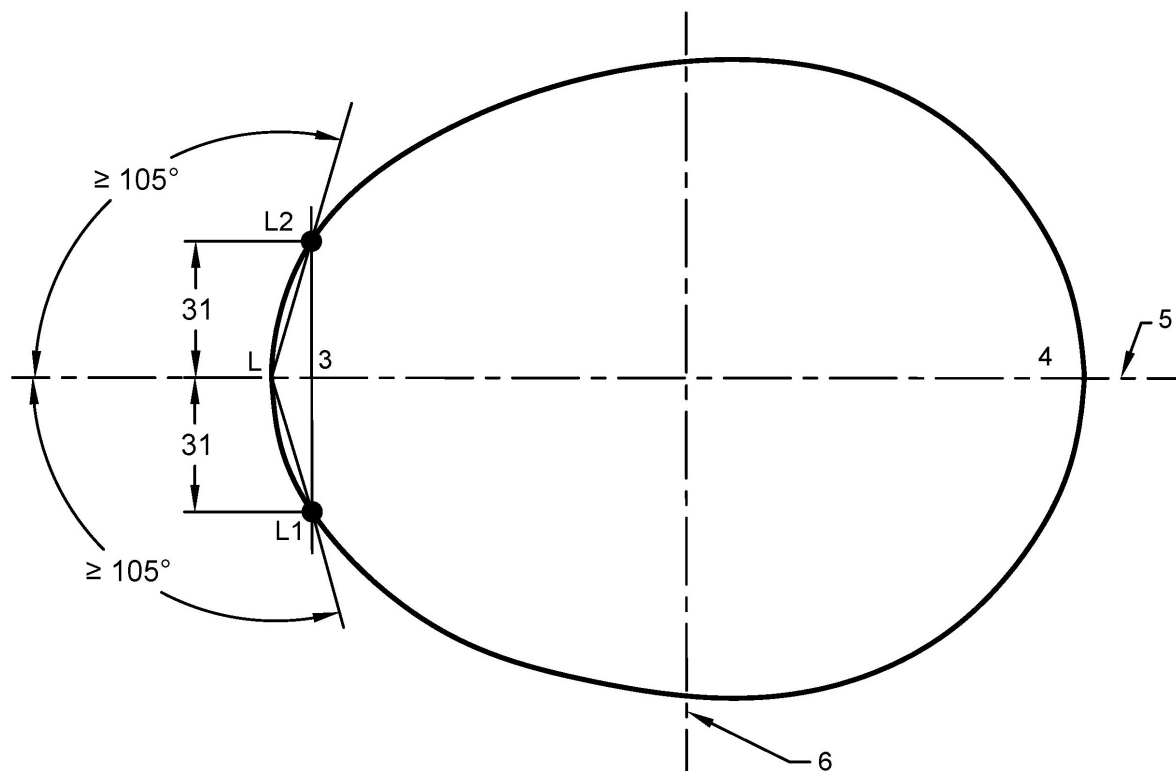

1B SECTION OF HEADFORM IN REFERENCE PLANE

Key

- 1 Reference plane
- 2 Basic plane
- 3 Front
- 4 Back
- 5 Longitudinal vertical median plane
- 6 Central transverse vertical plane

NOTES

- 1 Longitudinal vertical median plane [see 2.8 of CED 22(22809)WC]
- 2 Central transverse vertical plane [see 2.9 of CED 22(22809)WC]

All dimensions in millimetres

FIG. 1 FIELD OF VISIONIS

4.4 Shock Absorbing Capacity

The helmet shall give protection to the forehead, rear, sides, temples, and crown of the head. When tested in accordance with 5.3 and 5.4, the peak acceleration shall not, for each impact, exceed 250 g for the velocity of $5.42^{+0.1}_0$ m/s on the flat anvil, and $4.57^{+0.1}_0$ m/s on the kerbstone anvil.

NOTE — These are theoretically equivalent to 1 497 mm and 1 064 mm drop heights, respectively.

4.5 Durability

After testing, the helmet shall not have any damage that could seriously hurt the wearer (sharp edges, points).

4.6 Retention System

4.6.1 General

Means shall be provided for retaining the helmet on the wearer's head. All parts of the retention system shall be securely attached to the helmet.

4.6.2 Chin Strap

The chin strap shall not include a chin cup. Any chin strap shall be no less than 15 mm wide. Chin straps may be fitted with means of enhancing comfort for the wearer.

4.6.3 Fastening Device

Any retention system shall be fitted with a device to adjust and maintain tension in the system. The device shall be capable of adjustment so that the buckle does not sit on the jawbone.

4.6.4 Colour

No part of the retention system shall be coloured green.

NOTE — It is recommended that the opening mechanism be marked with red or orange colour.

4.6.5 Strength

When tested in accordance with **5.5**, the dynamic extension of the retention system shall not exceed 35 mm and the residual extension shall not exceed 25 mm. For this purpose, extension includes slippage of the fastening device.

Damage to the retention system shall be accepted provided that the above requirements are met.

NOTE — In this test, slippage of the fastening device can be measured and recorded separately from other contributions to the extension, but this is for information only and is not subject to a separate requirement.

4.6.6 Effectiveness

When tested in accordance with **5.6** the helmet shall not come off the headform.

4.6.7 Ease of Release

Following the strength test in accordance with **5.5** and with the load still applied, it shall be possible to open the release system with one hand.

5 TESTING

5.1 Headforms

The headforms used shall comply with *CED 22(22809)WC*. The sizes in Table 1 shall be used, except for determination of shock absorbing capacity, for which only size designations 495, 535, 575, 605 and 625 shall be used.

For determination of retention system strength and ease of release, the headforms used shall comply with *CED 22(22809)WC* at least down from the basic plane.

Table 1 Sizes of Headforms
(Clause 5.1)

SI No.	Size Designation	Inside Circumference of Helmet
(1)	(2)	mm (3)
i)	455	460
ii)	465	470
iii)	475	480
iv)	485	490
v)	495 (A)	500
vi)	515 (C)	520
vii)	535 (E)	540
viii)	555 (G)	560
ix)	575 (J)	570
x)	585 (K)	580
xi)	605 (M)	600
xii)	625 (O)	620

5.2 Inspection and Determination of Mass

Inspect the helmet to ascertain whether it is suitable for its intended purpose and fulfils the general requirements in **4.2**. Determine the mass of the helmets of the same size submitted for testing. Calculate and record the mean value in g rounded off to the nearest 10 g, stating the size of the helmet.

5.3 Number of Samples and Sequence of Tests

For each helmet type, four helmets for each headform size that fits within the manufacturers' claimed head size range shall be submitted for testing.

The sequence of tests performed on each helmet size and the tests performed on the same sample are given in Table 2.

Table 2 Sequence of Test and Tests Per Sample
(Clause 5.3)

SI No.	Performance Test	Sequence of Test	Sample Number		
			(4)	(5)	(6)
(1)	(2)	(3)	(4)	(5)	(6)
i)	Retention system effectiveness (5.6)	First	1	-	-
ii)	Shock absorbing capacity (5.4)	Second	1	2	3
iii)	Retention system strength (5.5)	Third	-	2	3

The fourth sample is reserved as a reference sample, which can be used by the test laboratory in case of doubt about any of the performance requirements.

5.4 Determination of Shock Absorbing Capacity

5.4.1 Test Area

- Take a headform of appropriate size designation and mark a point B, midway between point A' [the point where the AA' plane, as defined in CED 22(22809)WC, exits the back of the headform] and point F (see Fig. 1 and Fig. 2).
- Place the helmet on the headform. Apply a vertical load of 50 N on the crown of the helmet in order to stabilize the helmet on the headform. Position the front edge of the helmet to meet the upwards field of vision specified in 4.3 or to the manufacturer's normal wearing position if this is detailed by the manufacturer and results in greater than the specified upwards vision.
- Draw the AA'' line (in the AA' plane) on the helmet.
- Draw a line on the helmet, parallel to and approximately 20 mm above the AA'' line (for use as an angular measurement datum line).
- Mark the helmet at points B₁ and B₂. These points are the sideways horizontal projection of point B on to the outer surface of the helmet.
- Draw a line RR' on the helmet passing through B₁ and B₂, the line being angled 10° upwards toward the front of the helmet relative to the datum line drawn in (d).

The area above the line drawn in (f) is the test area for impacts on to the flat anvil. The area above the line RWA'' is the test area for impacts on to the kerbstone anvil, point W being the intersection of the lines marked in accordance with (c) and (f) above.

5.4.2 Conditioning

5.4.2.1 High temperature conditioning

The helmet shall be exposed to a temperature of 50 °C ± 2 °C for not less than 4 h and not more than 6 h.

5.4.2.2 Low temperature conditioning

The helmet shall be exposed to a temperature of $-20\text{ °C} \pm 2\text{ °C}$ for not less than 4 h and not more than 6 h.

5.4.2.3 Artificial ageing

The outer surface of the protective helmet shall be exposed successively to:

- a) Ultraviolet irradiation by a 125 W xenon-filled quartz lamp for 48 h at a range of 250 mm;
- b) Spraying for 4 h to 6 h with water at ambient temperature at the rate of 1 l/min.

NOTE — A method for artificial ageing is described in Annex A. This method may be used as an alternative to the conditioning according to **5.4.2.3**.

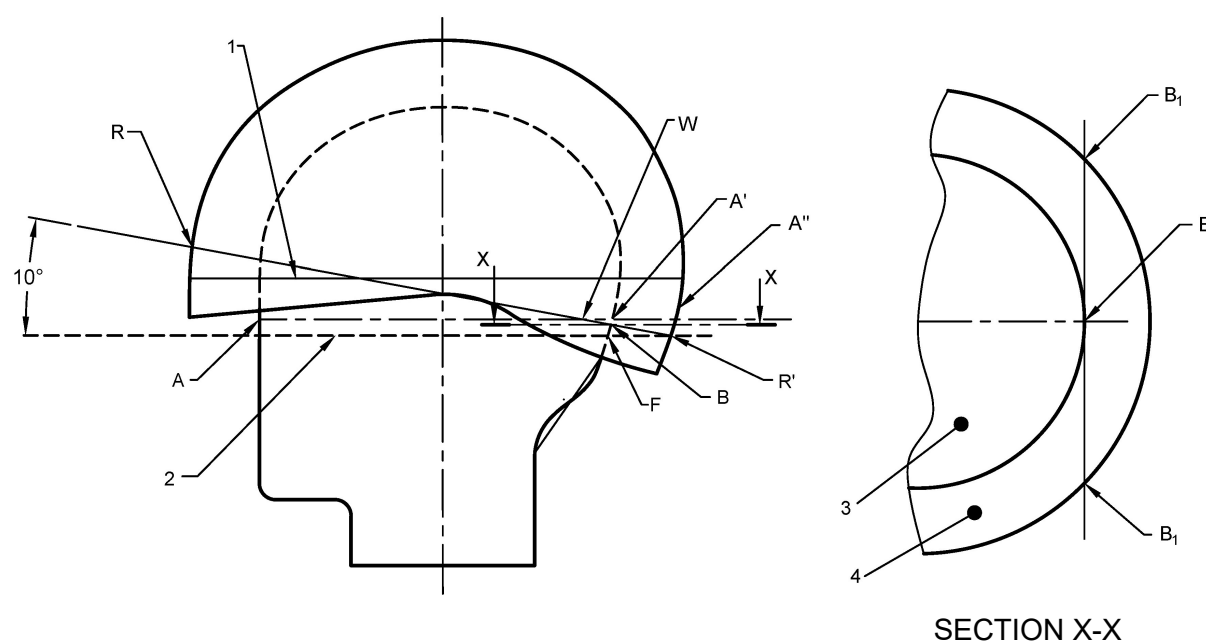
**Key**

- 1 Angular displacement datum
- 2 Reference plane
- 3 Headform
- 4 Helmet

FIG. 2 DEFINITION OF TEST AREA

5.4.3 Apparatus**5.4.3.1 Description**

The test apparatus shall comprise:

- a) an anvil rigidly fixed to a base;
- b) a free fall guidance system;
- c) a mobile system supporting the helmeted headform;

- d) a metal headform fitted with a tri-directional accelerometer;
- e) an accelerometer output recording and conditioning system; and
- f) a system by which the point of impact can be brought into correspondence with the centre of the anvil.

The principle is shown in Fig. 3.

5.4.3.2 Base

The base shall be monolithic and made of steel or concrete or a combination of these materials and have a mass of at least 500 kg. No part of the base or anvil shall have a resonant frequency liable to affect the measurements.

5.4.3.3 Anvil

A flat steel anvil having a circular impact face of $130 \text{ mm} \pm 3 \text{ mm}$ diameter. A steel anvil simulating a kerbstone and having two faces each inclined at $52.5^\circ \pm 2.5^\circ$ to the vertical and meeting along a striking edge with a radius of $15 \pm 0.5 \text{ mm}$. The height shall be not less than 50 mm and the length not less than 125 mm.

5.4.3.4 Mobile system and guides

The mobile system supporting the headform shall be such that its characteristics do not affect the measurement of acceleration at the centre of gravity of the headform. It shall also be such that any point in the test area can be positioned vertically above the centre of the anvil.

5.4.3.5 Accelerometer and measuring assembly

The tri-directional accelerometer shall be capable of measuring and recording accelerations up to 2 000 g and its maximum mass shall be 50 g.

The measuring system, including the drop assembly, shall have a frequency response in accordance with channel frequency class (CFC) 1000 (see ISO 6487).

The measuring system shall include equipment to record the velocity of the headform.

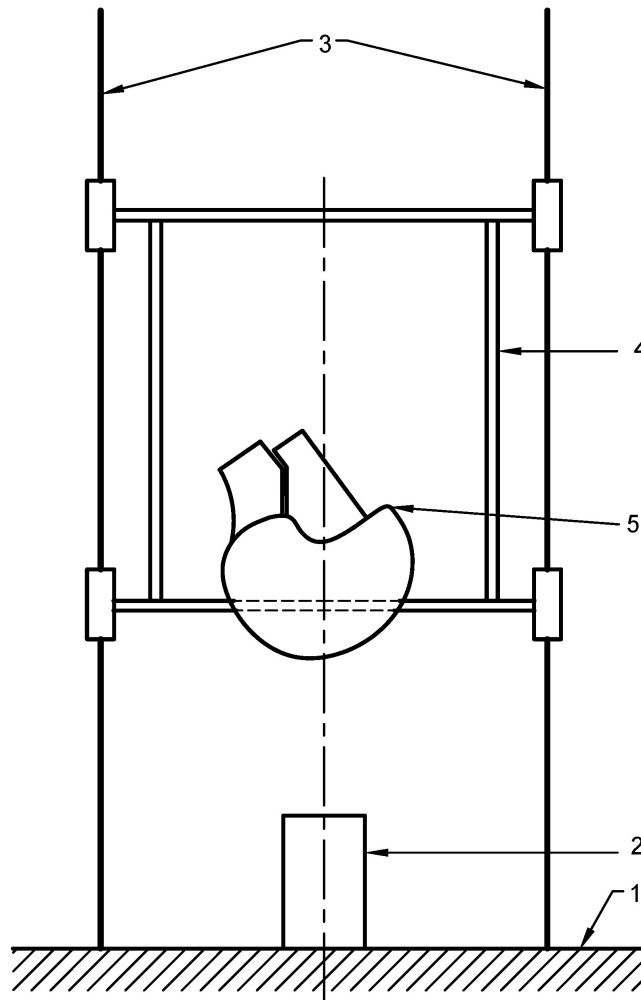
**Key**

- 1 Base
- 2 Anvil
- 3 Guides
- 4 Support dolly
- 5 Headform with helmet

FIG. 3 PRINCIPLE OF APPARATUS FOR DETERMINATION OF SHOCK ABSORBING CAPACITY

5.4.3.6 Headforms

The Headforms to be used shall comply with *Doc: CED 22(22809)WC* (see 5.1).

5.4.4 Procedure

The testing for shock absorption capacity shall be carried out in accordance with Table 3.

Table 3 Test parameters
(Clause 5.4.4)

SI No. (1)	Sample Number (2)	Conditioning (3)	Anvil (4)
i)	1	High temperature	Kerbstone
		No reconditioning	Flat
ii)	2	Low temperature	Flat
		No reconditioning	Kerbstone
iii)	3	Artificial ageing	Kerbstone
		No reconditioning	Flat

Make the first impact within 1 min and all further impacts within 3 min from removal of the helmet from the conditioning chamber.

Impact the helmets on sites selected by the test laboratory to present worst case conditions. Use the kerbstone anvil without any restriction on its orientation. In each series of tests on a model, conduct impacts on each perceived weak area (that is ventilation features, retention anchorages or webbing supports) which fall within the test area. The impact sites on each sample shall be separated by a minimum distance of 150 mm along the chord. The impact site shall be centred over the centre of the anvil.

The headform shall never be turned so that the vertical axis comes below the horizontal plane even if the test area allows. See Fig. 3.

In the event of there being no helmet material at the impact site, then the adjacent material shall manage the energy of such an impact. In the case where anvil/headform contact can be made at the setting up stage for an impact, the result shall be deemed a failure, without conducting the test.

Measure the velocity of the helmeted headform at a distance not exceeding 60 mm prior to impact to an accuracy of 1 percent.

5.5 Determination of Retention System Strength and Ease of Release

5.5.1 Apparatus

5.5.1.1 Description

The test apparatus shall comprise:

- a) a means to hold the helmet with headform and loads;
- b) a headform equipped with a loading device comprising a guide, an arrest device, and a drop weight; and
- c) a retention system extension measuring system.

A suitable apparatus is shown in Fig. 4.

5.5.1.2 Headform

The headform to be used shall comply, at least down to the basic plane, with *Doc: CED 22(22809)WC* (see 5.1).

5.5.1.3 Loadbearing device

The load bearing device shall consist of a chin strap stirrup with a round or square guide bar. The bar shall have a steel end stop. The chin strap stirrup shall consist of two metal bars each with a diameter of 12.5 ± 0.5 mm that have a centre distance of 76 ± 1 mm. The guide bar shall be provided with a cylindrical weight having a mass of 4 ± 0.2 kg and allow for a drop of the weight of 600 ± 5 mm. The mass of the entire loading apparatus excluding the 4 kg weight shall be 5 ± 0.5 kg.

5.5.1.4 Measuring device

A device to measure the vertical displacement of the chin strap fixture shall be included.

5.5.1.5 Procedure

Place the helmet on the headform. Fasten the chin strap under the stirrup bars so that the entire test apparatus hangs freely on the retention system. Place a preload ballast of 5 ± 0.5 kg on the helmet. Then raise the drop weight and allow it to fall and impact the end stop. During the test, measure the dynamic displacement of the chin strap stirrup. After 2 min, measure the residual displacement with the drop weight still on the end stop. Ascertain whether or not the system can be released by one hand.

5.6 Determination of Retention System Effectiveness

5.6.1 Apparatus

The apparatus shall comprise:

- a) a drop weight with a mass of 10.0 ± 0.1 kg;
- b) a guiding system with a total mass of 3.0 ± 0.1 kg allowing the drop weight to drop in a guided free fall;
- c) a flexible strap and a hook attached to the guiding system running over a pulley with a diameter of 100 mm. The extension of the strap shall be less than 18 mm/m under a load of 1 000 N;
- d) headforms according to *Doc: CED 22(22809)WC* (see 5.1);
- e) a base to hold the Headforms.

Fig. 5 shows the principle of the apparatus.

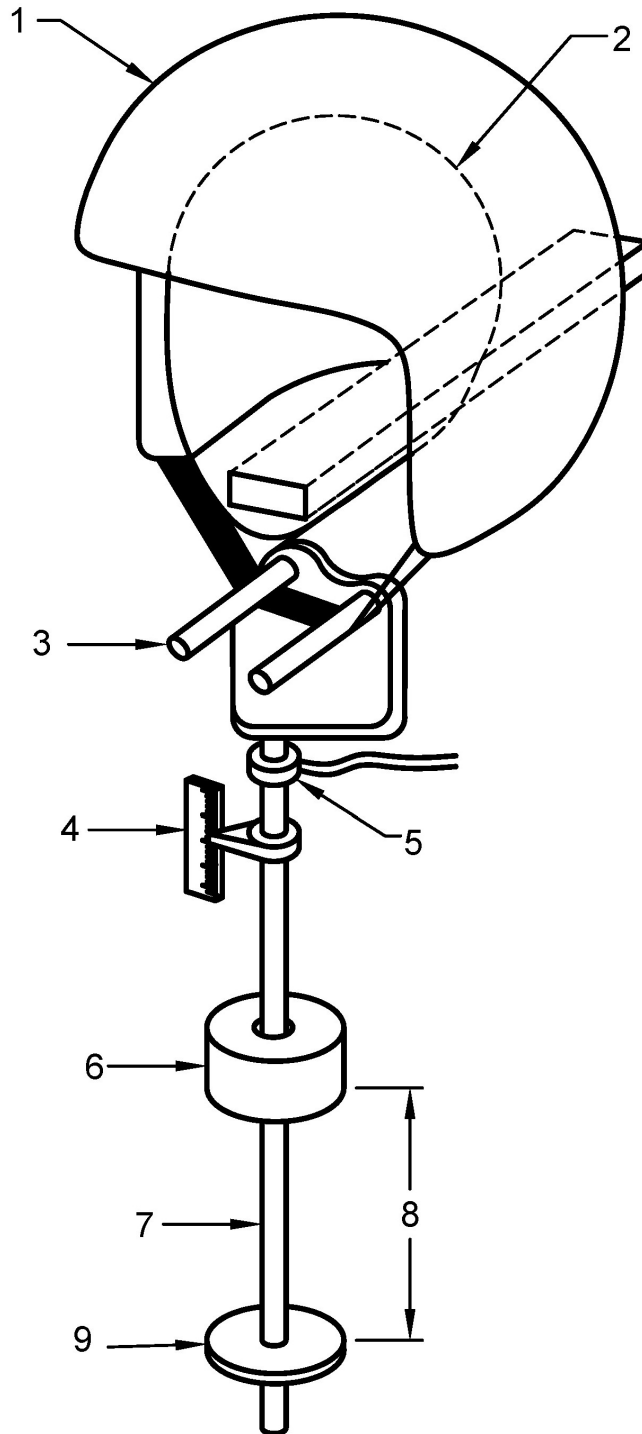

Key

- | | | | |
|---|----------------------------|---|---------------------------|
| 1 | Helmet | 6 | Drop weight 4 kg ± 0,2 kg |
| 2 | Headform | 7 | Guide bar |
| 3 | Chin strap stirrup | 8 | Drop height 600 mm ± 5 mm |
| 4 | Extension measuring device | 9 | Stop anvil |
| 5 | Load cell (optional) | | |

FIG. 4 EXAMPLE OF AN APPARATUS FOR TESTING OF RETENTION SYSTEM STRENGTH

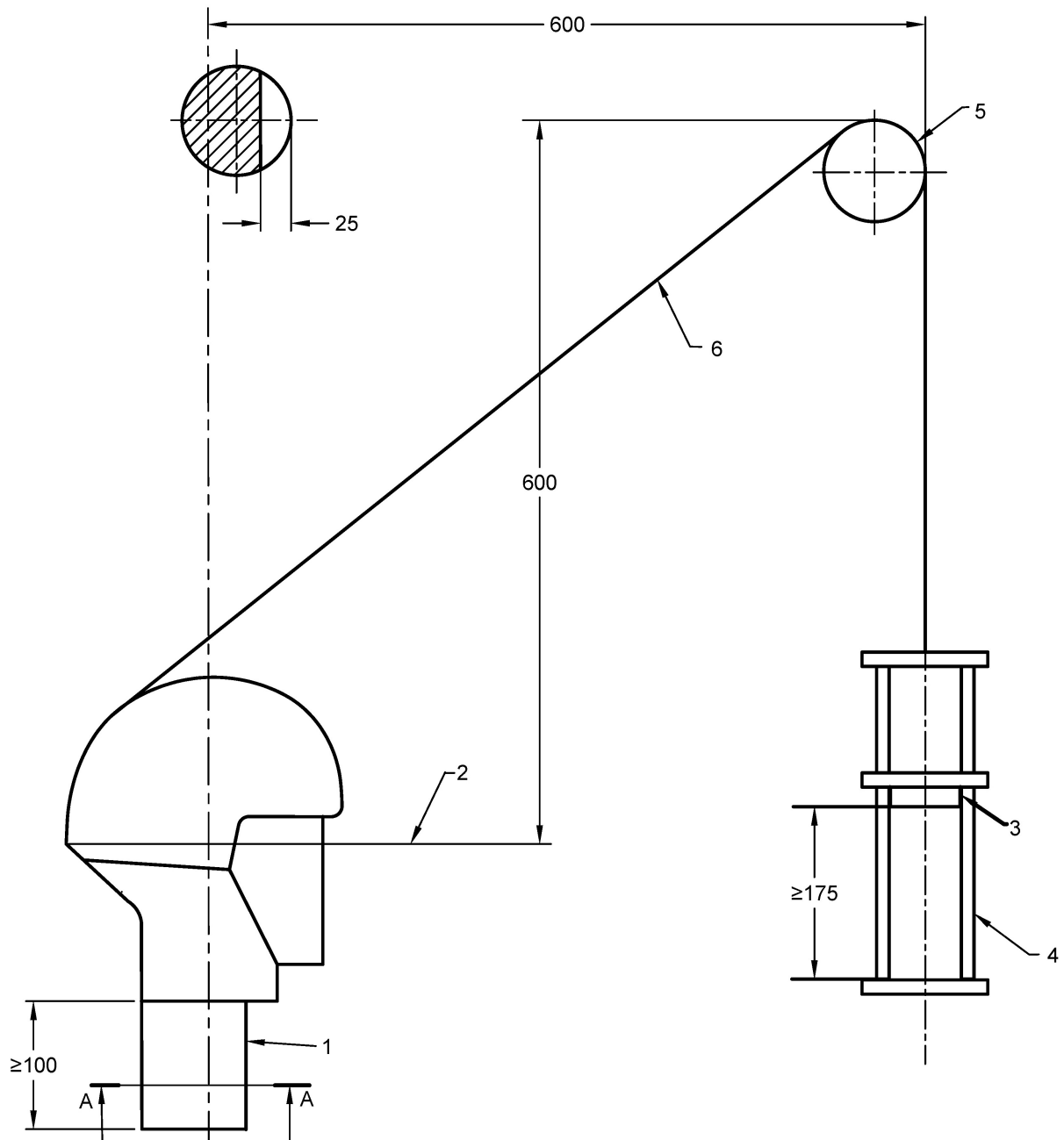

Key

- 1 Base
- 2 Reference plane
- 3 Drop weight mass 10 kg
- 4 Guiding system mass 3 kg
- 5 Pulley \varnothing 100 mm
- 6 Flexible strap $\geq \varnothing$ 3 mm

All dimensions in millimetres

FIG. 5 APPARATUS FOR TESTING OF THE RETENTION SYSTEM EFFECTIVENESS

5.6.2 Procedure

Fit the helmet according to the manufacturer's instructions to the appropriate headform which shall be the smallest and the largest and intermediate sizes measured for the helmet type.

Adjust the retention system to be as tight as possible. Hook the strap to the rear of the helmet.

Release the drop weight and allow it to fall through a distance of (175 ± 5) mm. Observe whether or not the helmet comes off.

5.7 Determination of Field of Vision

To carry out the test, the test laboratory shall select the size it considers likely to yield the least favourable result for the helmet type.

Place the helmet on a headform of appropriate size. Apply a load of 50 N on the crown of the helmet in order to stabilize the helmet on the headform. Ascertain that the vertical median plane of the helmet coincides with the vertical median plane of the headform.

Adjust the helmet on the headform according to the manufacturer's instructions, if supplied. In that position, determine if the helmet complies with the requirements for field of vision in **4.3**.

5.8 Test Report

The test report shall contain at least the following information:

- a) Identification details of the helmets including range of sizes;
- b) Results of the test in accordance with **5.2** to **5.7**;
- c) Date of testing; and
- d) Name of the test laboratory.

6 MARKING

6.1 Each helmet shall be marked in such a way that the following information is easily legible by the user and is likely to remain legible throughout the life of the helmet:

- a) Name or trademark of the manufacturer;
- b) Designation of the model;
- c) Designation, which shall be one or more of the following: Helmet for pedal cyclists, skateboards, or roller skaters;
- d) Size or size range of the helmet, quoted as the circumference (in centimetres) of the head which the helmet is intended to fit;
- e) Weight of the helmet (the average mass in grams determined according to **5.2**);
- f) Year and month of manufacture;
- g) Following text:

Warning — This helmet should not be used by children while climbing or doing other activities when there is a risk of strangulation/hanging if the child gets trapped with the helmet. In addition, if the helmet has components made of material which are known to be adversely affected by contact with hydrocarbons, cleaning fluids, paints, transfers or other extraneous additions, the helmet shall carry an appropriate warning. If there is a consumer sales packaging, the information specified in (a), (b), (d), and (h) shall also be given on that package. The text shall be of minimum font size 12.”

6.2 Information to be Supplied by the Manufacturer

With every packing to the helmet, the following clear information, preferably in English and local language, shall be given:

- a) That the helmet can only protect if it fits well, and that the buyer should try different sizes and choose the size which feels secure and comfortable on the head;
- b) That the helmet should be adjusted to fit the user, for example, the straps positioned so that they do not cover the ears, the buckle positioned away from the jawbone and the straps and buckle adjusted to be both comfortable and firm;
- c) How the helmet should be positioned on the head to ensure the intended protection is provided (for example, hat it should be placed so as to protect the forehead and not be pushed too far over the back of the head);
- d) That a helmet cannot always protect against injury;
- e) That a helmet subjected to a severe impact should be discarded and destroyed; and
- f) A statement of the danger of modifying or removing any of the original component parts of the helmet other than as recommended by the manufacturer, and that helmets should not be adapted for the purpose of fitting accessories in a way not recommended by the manufacturer.

6.3 BIS Certification Marking

The product (helmets) conforming to the requirements of this standard may be certified as per the conformity assessment schemes under the provisions of the Bureau of Indian Standards Act, 2016 and the Rules and Regulations framed thereunder, and the product may be marked with the Standard Mark.

ANNEX A
(informative)
(Clause 5.4.2.3)

ALTERNATIVE PROCEDURE FOR ARTIFICIAL AGEING

A-1 The helmet submitted to artificial ageing should be exposed to the radiation of a xenon arc lamp. The radiant energy of the lamp should be filtered to provide a spectral power distribution that closely approximates that of terrestrial daylight.

The helmet should be fixed on a cylindrical holder concentric to the lamp and which rotates at a speed of 1/min to 5/min around its axis.

Each helmet which will subsequently be tested for shock absorption should be orientated so that the area of test should be directed towards the lamp. The plane tangential to the shell at this point should be normal to a radius of the cylindrical holder.

The radiant energy incident in the plane of the test areas should be either measured or calculated from information provided by the manufacturer of the test apparatus. The exposure interval should be adjusted so that the exposed samples should receive a total energy of 1 GJ/m² over the wavelength range 280 nm to 800 nm.

The samples should be sprayed with distilled or demineralized water (having a conductivity below 5 µS/cm) intermittently with a cycle of 18 min spraying and 102 min without spraying. During the latter periods, the measured relative humidity should be 50 ± 5 percent.

The temperature within the test chamber should be measured with a black standard thermometer placed at the same distance from the lamp as the exposed test areas of the helmets. The temperature should be maintained at 70 °C ± 3 °C.

All other test and calibration conditions for the apparatus should be in accordance with method A of IS 17863 (Part 1), IS 17863 (Part 2), and IS 17863 (Part 3).

NOTES

- 1 Not all available test apparatus, otherwise meeting the requirements of IS 17863 (Part 1), IS 17863 (Part 2), and IS 17863 (Part 3), will incorporate sample holder frames of diameter sufficient to accommodate complete helmets.
- 2 The position of the water sprays may require adjustment in order to avoid interference with the test samples.
- 3 The energy output of the xenon arc should be capable of being reduced below normal operational levels so as to maintain acceptable intensities in the sample surface plane required by this procedure.