



मानक भवन, 9, बहादुर शाह ज़फर मार्ग, नई दिल्ली - 110002
Manak Bhawan, 9, Bahadur Shah Zafar Marg, New Delhi - 110002
Phones: 23230131 / 2323375 / 23239402
Website: www.bis.gov.in, www.manakonline.in

व्यापक परिचालन मसौदा

हमारा संदर्भ : सीईडी 13/टी-111

01 जनवरी 2025

तकनीकी समिति : भवन निर्माण रीति विषय समिति, सीईडी 13

प्राप्तकर्ता :

1. सिविल अभियांत्रिकी विभाग परिषद, सीईडीसी के सभी सदस्य
2. भवन निर्माण रीति विषय समिति, सीईडी 13 के सभी सदस्य
3. रुचि रखने वाले अन्य निकाय।

महोदय/ महोदया,

निम्नलिखित मानक का मसौदा संलग्न है:

प्रालेख संख्या	शीर्षक
सीईडी 13(27189)WC	संरचनात्मक रोगन सिलिकॉन सीलेंट - विशिष्ट का भारतीय मानक मसौदा (आई सी एस ICS 81.040.20; 91.100.50)

कृपया इस मसौदे का अवलोकन करें और अपनी सम्मतियाँ यह बताते हुए भेजे कि यह मसौदा प्रकाशित हो तो इन पर अमल करने में आपको व्यवसाय अथवा कारोबार में क्या कठिनाइयाँ आ सकती हैं।

सम्मतियाँ भेजने की अंतिम तिथि: 01 फ़रवरी 2025

सम्मति यदि कोई हो तो कृपया अधोहस्ताक्षरी को ई-मेल द्वारा ced13@bis.gov.in पर या उपरलिखित पते पर, संलग्न फ़ॉर्मेट में भेजें। सम्मतियाँ बीआईएस ई-गवर्नेंस पोर्टल, www.manakonline.in के माध्यम से ऑनलाइन भी भेजी जा सकती हैं।

यदि कोई सम्मति प्राप्त नहीं होती है अथवा सम्मति में केवल भाषा संबंधी त्रुटि हुई तो उपरोक्त प्रालेख को यथावत अंतिम रूप दे दिया जाएगा। यदि सम्मति तकनीकी प्रकृति की हुई तो विषय समिति के अध्यक्ष के परामर्श से अथवा उनकी इच्छा पर आगे की कार्यवाही के लिए विषय समिति को भेजे जाने के बाद प्रालेख को अंतिम रूप दे दिया जाएगा।

यह प्रालेख भारतीय मानक ब्यूरो की वेबसाइट www.bis.gov.in पर भी उपलब्ध है।

धन्यवाद।

भवदीय
ह/-
द्वैपायन भद्र
(वैज्ञानिक 'ई' एवं प्रमुख)
(सिविल अभियांत्रिकी विभाग)

संलग्न: उपरिलिखित

**WIDE CIRCULATION DRAFT**

Our Reference: CED 13/T-111

01 January 2025**TECHNICAL COMMITTEE: BUILDING CONSTRUCTION PRACTICES**
SECTIONAL COMMITTEE, CED 13**ADDRESSED TO:**

1. All Members of Civil Engineering Division Council, CEDC
2. All Members of Building Construction Practices Sectional Committee, CED 13
3. All others interested.

Dear Sir/ Madam,

Please find enclosed the following draft:

Doc No.	Title
CED 13(27189) WC	Draft Indian Standard for Structural Glazing Silicone Sealants - Specification (ICS: 81.040.20; 91.100.50)

Kindly examine the attached draft and forward your views stating any difficulties which you are likely to experience in your business or profession, if this is finally adopted as National Standard.

Last Date for Comments: 01 February 2025

Comments if any, may please be made in the enclosed format and emailed at ced13@bis.gov.in or sent at the above address. Additionally, comments may be sent online through the BIS e-governance portal, www.manakonline.in.

In case no comments are received or comments received are of editorial nature, kindly permit us to presume your approval for the above document as finalized. However, in case comments, technical in nature are received, then it may be finalized either in consultation with the Chairman, Sectional Committee or referred to the Sectional Committee for further necessary action if so desired by the Chairman, Sectional Committee.

The document is also hosted on BIS website www.bis.gov.in.

Thanking you,

Yours faithfully,
Sd/-
(Dwaipayan Bhadra)
Head (Civil Engineering)

Encl: As above

BUREAU OF INDIAN STANDARDS

DRAFT FOR COMMENTS ONLY

(Not to be reproduced without the permission of BIS or used as an Indian Standard)

Draft Indian Standard

STRUCTURAL GLAZING SILICONE SEALANTS – SPECIFICATION

ICS 81.040.20;91.100.50

Building Construction Practices
Sectional Committee, CED 13

Last date of comments
01 February 2025

FORWORD

(Formal clause will be added later)

Structural glazing is a method utilizing silicon adhesive to attach glass, metal or other panel material to the structure of a building. Wind load and other impact loads on the facade are transferred from the glass or panel, through the structural silicone sealant to the structure of the building. The sealant must maintain adhesive and cohesive integrity as the facade is subjected to wind load and thermal stresses.

This standard is intended to provide guidance on the proper use of silicone sealants in structural glazing application.

This standard addresses the parameters such as initial cure properties, physical properties and also the application requirements of the glazing sealants. This standard also includes an informative annex (Annex J) in which information about deglazing, shelf life, storage and transportation, curing and modulus of elasticity is mentioned.

The figures given in this standard are typical and the suggested test procedures therein shall be followed.

In the formulation of this standard, considerable assistance has been derived from below mentioned standard:

- a) ASTM C920-18 'Standard specification for elastomeric joint sealants'
- b) ASTM C1184-18 'Standard specification for structural silicone sealants'
- c) ASTM C1401-14 'Standard guide for structural sealant glazing'
- d) ETAG 002 (Edition 1999) 'Guideline for European technical approval for structural sealant glazing kits (SSGK)'
- e) ISO 8339:2005 Building construction — Sealants — Determination of tensile properties (Extension to break)
- f) ISO 28278-1 : 2011 'Glass in building — Glass products for structural sealant glazing — Part 1: Supported and unsupported monolithic and multiple glazing'

This standard contributes to the Sustainable Development Goal 9 'Industry, Innovation and Infrastructure: Build resilient infrastructure, promote inclusive and sustainable industrialization and foster innovation'.

The composition of the Committee responsible for the formulation of this standard will be added at later stage.

For the purpose of deciding whether a particular requirement of this standard is complied with the final value, observed or calculated, expressing the result of a test or analysis, shall be rounded off in accordance with IS 2 : 2022 'Rules for rounding off numerical values (*second revision*)'. The number of significant places retained in the rounded off value should be the same as that of the specified value in this standard.

BUREAU OF INDIAN STANDARDS**DRAFT FOR COMMENTS ONLY***(Not to be reproduced without the permission of BIS or used as an Indian Standard)**Draft Indian Standard***STRUCTURAL GLAZING SILICONE SEALANTS — SPECIFICATION****1 SCOPE**

This standard describes the properties of cold liquid applied, one-component or multicomponent, chemically curing elastomeric structural silicone sealants herein referred to as the sealant.

The purpose of these sealants is to structurally bond components of glazing systems. The system may comprise of materials of different substrates but not limited to glass (coated/clear), aluminium with different type of surface treatment, metal panels, etc.

2 REFERENCES

The standards given below contain provisions which through reference in this text, constitute provision of this standard. At the time of publication, the editions indicated were valid. All standards are subject to revision and parties to agreements based on this standard are encouraged to investigate the possibility of applying the most recent edition of these standards:

<i>IS No.</i>	<i>Title</i>
IS 3400	Methods of test for vulcanized rubber:
(Part 1) : 2021/ ISO 37 : 2017	Tensile stress-strain properties (<i>fourth revision</i>)
(Part 12) : 2022/ ISO 34-1 : 2015	Tear strength — Trouser, angle and crescent test piece (<i>first revision</i>)
(Part 23/Sec 1) : 2018/ISO 7619-1 : 2010	Rubber — Determination of indentation hardness by means of pocket hardness meters, Section 1 Durometer method (Shore hardness) (<i>first revision</i>)
IS 10959 : 2024/ ISO 6927 : 2021	Sealants for building purpose — Glossary of Terms (<i>second revision</i>)

3 TERMINOLOGY

For the purpose of this standard the terms and definitions given in IS 10959 shall apply.

4 STANDARD LABORATORY CONDITIONS

The conditions consist of equipment set points for relative humidity of 65 percent and air temperature of 27 °C at ambient atmospheric pressure, with tolerances (allowed

operational fluctuations of ± 10 percent relative humidity and ± 2 °C air temperature).

NOTE — The laboratory environment shall be free from direct sunrays and the effects of vapours, gases, and other contaminants. This standard does not address tighter operational fluctuation of temperature and relative humidity that may be required in some laboratories.

5 SIGNIFICANCE AND USE

This specification assists in selecting sealants that meet certain minimum standards of performance. Although this specification qualifies a sealant for use, it does not address the sealant design calculation, adhesion capability of the sealant for a specific substrate nor the compatibility of the sealant with the materials it contacts. Adhesion and compatibility characteristics required for specific substrates or finish can be determined by test method prescribed in the Annex F and Annex G for adhesion and compatibility respectively. To properly specify a sealant for the intended use when using this standard, it is essential that the applicable type and use be included.

6 CLASSIFICATION OF SEALANTS

A sealant qualifying under this specification shall be classified on type and uses as given below:

<i>Sl No.</i>	<i>Type</i>	<i>Grade</i>
(1)	(2)	(3)
i)	Type S — Single-component sealant	Grade NS (non-sagging)
ii)	Type M — Multicomponent sealant	Grade NS (non-sagging)

7 MATERIALS AND MANUFACTURE

7.1 A single-component sealants shall be a homogeneous mixture of a consistency suitable for immediate application by hand or pressure caulking gun or by hand tool and shall be applied in accordance with the written recommendations of the sealant manufacturer. The sealant when completely cured shall form an elastomeric rubber capable of bonding and maintaining a seal.

7.2 Multicomponent sealants have two or more components. The resulting mixture shall be uniform and of a consistency suitable for immediate application by hand or pressure caulking gun, or by hand tool. Multicomponent sealant shall be mixed and applied in accordance with the written recommendations of the sealant manufacturer. The sealant when completely cured shall form an elastomeric rubber capable of bonding and maintaining a seal.

8 MATERIAL TEST CERTIFICATE (MTC), STORAGE AND DISPOSAL

8.1 Material test certificate (MTC) from the sealant manufacturer shall be made available for every batch/lot. The lot/batch acceptance tests as marked in the Table 1 shall be submitted before the delivery of material to the project site, attesting that the sealant materials conform to the specification requirements.

8.2 Material shall be stored and protected in accordance with a manufacturer's printed instructions. Expired material shall not be discarded and shall be disposed in accordance with the guideline outlined by the local authority.

9 REQUIREMENTS

The physical, mechanical and performance properties of the sealant shall conform to the requirements described in Table 1.

When a primer (see Note) is required by the sealant manufacturer, all tests performed in accordance with this specification shall be performed with the primer. When a primer is not required by the sealant manufacturer, all tests performed in accordance with this specification shall be performed without a primer.

NOTE — Proper use of primer shall be as per the manufacturer recommendation. The standard substrate for this specification is clear, uncoated float glass.

Table 1 Requirement of Sealant

(Clauses 8, 9, B-5 and E-5.5)

SI No.	Property	Requirement	Test Method, Ref to
(1)	(2)	(3)	(4)
i)	Extrusion rate ¹⁾ , g/min, <i>Minimum</i>	100	Annex A
ii)	Durometer hardness ¹⁾ , Shore A (7 days at room temperature)	30 to 60	Annex B and IS 3400 (Part 23/Sec 1)
iii)	Heat aging ²⁾ :		
	a) Weight loss, in percentage, <i>Max</i>	10	Annex C
	b) Cracking	None	
	c) Chalking	None	
iv)	Slump ¹⁾ , <i>Max</i> :		Annex D
	a) Vertical slump, mm	5 mm	
v)	Tack-free time ¹⁾ (single part), <i>Max</i>	No transfer in 3 h	Annex E
vi)	Adhesion-in-peel ²⁾		

SI No.	Property	Requirement	Test Method, Ref to
(1)	(2)	(3)	(4)
	a) For dry test	100 percentage Cohesive failure with minimum 5 N/mm	Annex F
	b) For wet test	≥ 95 percentage Cohesive failure with minimum 5 N/mm	
vii)	Tear strength ²⁾ , N/mm, <i>Min</i>	5	IS 3400 (Part 12) - Crescent test piece die
viii)	Compatibility ²⁾	No discolouration, no loss of adhesion	Annex G
ix)	Tensile stress-strain from dumbbell specimen ¹⁾ (<i>Min</i>):		
	a) Tensile — 7 days at room temperature, MPa	1.4	IS 3400 (Part 1) - Dumb-bell - Type 1
	b) Elongation — 7 days at room temperature, percent	300	
x)	Ultimate tensile strength ²⁾ , (<i>Min</i>) (N/mm ²):		
	a) Standard Laboratory condition	0.6	
	b) 88 °C ± 2°C	0.6	Annex H
	c) -29 °C ± 2°C	0.6	
	d) Water immersion 7 days	0.6	
	e) A minimum of 5000 h weathering	0.6	

¹⁾ Lot/batch acceptance test: Testing done at regular interval from the produced lot/batch.

²⁾ Type test (type test are the test, done once in 3 years due to the intensity and duration of the testing, when ingredients and method of manufacturing remains the same).

10 PACKING AND MARKING

10.1 Packing

10.1.1 Single-component sealants are generally packed in moisture barrier packaging material such as plastic cartridges of generally 200 ml to 325 ml in volume and in multi-layered foil packs of 500 ml and 600 ml in volume.

10.1.2 The multi-component sealants are generally packed in steel drums and in plastic pails. The base materials are packed generally in 225 kg to 300 kg in steel drum, and crosslinker/catalyst/curing agents are packed in airtight container of plastic/steel drums between 17 kg and 25 kg.

10.2 Marking

Each package of the sealant shall indicate the following:

- a) Manufacturer's name or trademark;
- b) Mass;
- c) Batch number;
- d) Use by/or Expiry date; and
- e) Instructions for storage

10.2.1 BIS Certification Marking

The product(s) conforming to the requirements of this standard may be certified as per the conformity assessment schemes under the provisions of the *Bureau of Indian Standards Act, 2016* and the Rules and Regulations framed thereunder, and the products may be marked with the Standard Mark.

11 SAMPLING

Representative samples of the material shall be taken from each lot/batch and conformity of the material to the requirements of this standard shall be determined according to the testing methodologies outline in the annexes.

The following table shows the minimum size of a batch/lot for sampling the sealant.

Sl No.	Single Component		Multi Component	
	Sausage (1)	Cartridge (2)	Base (3)	Catalyst (4)
i)	Minimum 1 box in (0.1 percentage) of 10 MT	Minimum 1 box in (0.1 percentage) of 10 MT	Minimum 1 No. in 10 MT	Minimum 1 No. in 3 MT

ANNEX A

[Table 1, SI No. (i)]

STANDARD TEST METHOD FOR EXTRUSION RATE OF ELASTOMERIC SEALANTS

A-1 GENERAL

This test method covers two laboratory procedures for determining the extrusion rate of elastomeric sealants for use in building construction.

A-2 SIGNIFICANCE AND USE

A-2.1 Sealants are supplied with various rheological properties ranging from pourable liquids to non-sagging pastes. Single-component sealants are supplied ready for use upon opening the container. Multicomponent sealants are supplied as a base component(s) and a curing agent separately packaged. After mixing the two or more parts, the sealant is ready for application. This test method is intended to provide a means to measure the extrusion rate spanning the range of rheological properties.

A-2.2 This test method provides for an option to use either a metal or plastic nozzle. This test method measures the volume of sealant extruded over a given period of time at a given pressure (kPa).

A-3 APPARATUS

A-3.1 High density polyethylene cartridge, with plunger and cap, 200 ml to 325 ml capacity, with the front end having an inside diameter of $13.5 \text{ mm} \pm 0.5 \text{ mm}$.

A-3.2 Metal / Plastic nozzle, threaded to fit threaded end of polyethylene cartridge with the dimensions given in Fig. 1.

A-3.3 Air supply, to provide $620 \text{ kPa} \pm 30 \text{ kPa}$ pressure with appropriate fitting and air lines to attach to an air powered gun for convenience of use.

A-3.4 Caulking gun, 200 ml to 325 ml capacity, air powered.

A-3.5 Time device, a clock or stopwatch graduated in seconds.

A-3.6 Small container, can, cup, and so forth, as receiver for extruded sealant.

A-3.7 Balance, accurate to $\pm 0.1 \text{ g}$.

A-3.8 Spatula

A-4 TEST CONDITIONS

Unless otherwise specified by those authorizing the tests, standard conditions shall be used.

A-5 PROCEDURE

A-5.1 Condition the unopened container of sealant for at least 16 h at standard conditions.

NOTE — Curing times and conditions for multicomponent mixed compounds may vary. Therefore, the length of time between mixing the components and testing the extrusion rate may vary. Record the time from mix completion to the start of the extrusion test.

A-5.2 For multiple component sealants, mix 400 g sealant with the proper amount of curing agent. Follow the mixing directions as recommended by the manufacturer.

A-5.3 Place a sufficient amount of sealant into the polyethylene cartridge to fill it completely with the plunger in place, and level with the back of the cartridge.

NOTE — The cartridge filling is most easily accomplished by extruding the sealant into the test cartridge through the nozzle end. Avoid any air entrapment, as this will significantly affect the accuracy of the results.

A-5.4 Attach the air supply and adjust the gage to read 620 kPa. Extrude a small amount of material to fill the nozzle and clear trapped air. Wipe off the end of the nozzle with a paper towel.

A-5.5 Extrude material into a suitable tared container(s). Record the weight of the extruded material and the time to the nearest second. The extrusion should be continued for a minimum of 15 s or until 20 g or more is collected. Repeat for two additional times. Average the three weights, if the three weights agree within ± 10 percent of the average, then calculate and report the extrusion rate in grams per minute as follows:

$$\text{Extrusion rate, } \left(\frac{\text{gm}}{\text{minute}} \right) = \frac{\text{Average weight extruded}}{\text{Time (minutes)}}$$

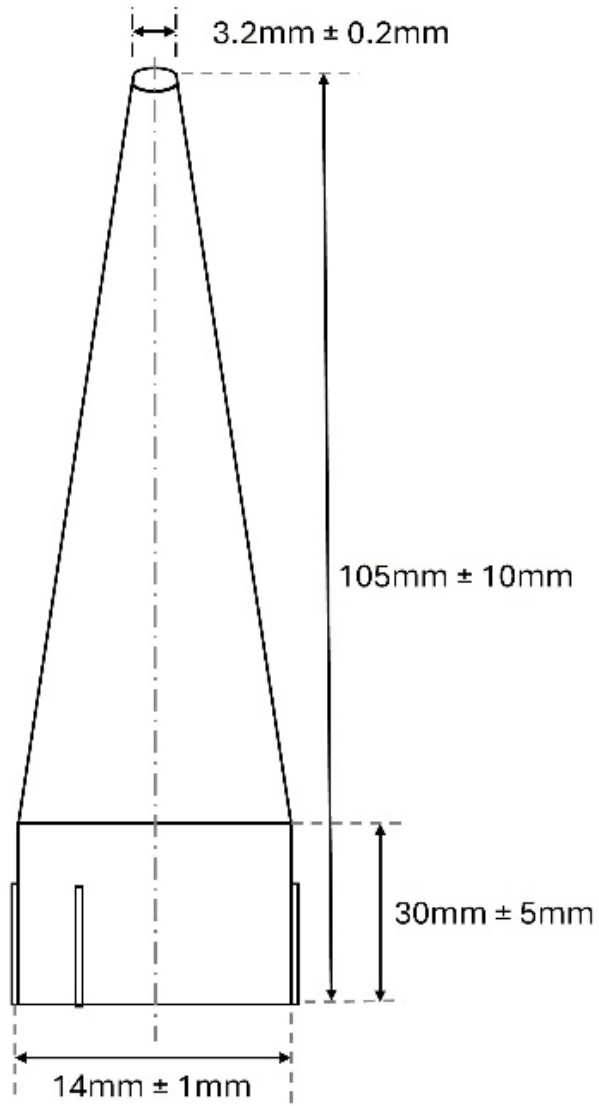

FIG. 1 METAL/PLASTIC NOZZLE DIMENSIONS

ANNEX B

[Table 1, Sl No. (ii)]

STANDARD TEST METHOD FOR INDENTATION HARDNESS OF ELASTOMERIC-TYPE SEALANTS BY MEANS OF A DUROMETER

B-1 GENERAL

This test method describes a laboratory procedure for determining indentation hardness of joint sealing compounds (single and multicomponent) intended for use in building construction.

B-2 SIGNIFICANCE AND USE

The results obtained by this test method are simply a measure of the indentation into the sealant material of the indenter under load; they are not generally considered a measure of abrasion or wear resistance of the sealant.

B-3 APPARATUS REQUIRED

B-3.1 Durometer, Type A, with a dial graduated in units from 0 to 100 (see test method IS 3400 (Part 23/Sec 1) for a description of the indenter and a method of calibration of the durometer.

B-3.2 Rectangular brass frame, with inside dimensions 130 mm × 40 mm × 6 mm.

B-3.3 Aluminium plates, two 80 mm × 150 mm.

B-3.4 Thin-bladed knife.

B-3.5 Standard laboratory condition.

B-3.6 Metal straightedge.

B-4 PROCEDURE

B-4.1 Test for Hardness of Multicomponent Sealants

B-4.1.1 Condition at least 250 g of base compound and appropriate amounts of curing agent for at least 24 h at standard conditions; then mix the components thoroughly for 5 min. Alternatively, metering and mixing equipment installed in the same environment with the material can also be used to get homogeneous mix of the sealant for the test.

B-4.1.2 Fill the brass frame, after centring it on the aluminium plate, with a portion of the conditioned compound and strike it off flat with a metal straightedge. Lift the frame from the sealant after separating it by running a thin-bladed knife along the inside of the frame. Prepare two such specimens and cure them for 14 days at standard conditions.

B-4.1.3 At the end of the curing period, take three hardness readings on each specimen at standard conditions. Hold the durometer on the surface of the specimen

and press it firm against the surface using a force of about 12.5 ± 0.5 N. Keep the pressure foot parallel to the surface of the specimen. Take the instantaneous indentation reading immediately after making firm contact between the pressure foot and the specimen. Equipment capable enough to exert the force automatically and capture the reading can also be used. After taking the first reading, shift the durometer (or specimen) to a new position in order to avoid errors due to fatigue and surface effects from the previous indentation. Take readings on smooth portions of the surface no closer than 13 mm from the edges of the sealant pat and also no closer than 25 mm from each other. Note the individual values, each rounded off to the nearest unit on the scale.

NOTES

1 In the case of a self-levelling sealant or compound, do not lift the brass frame until the sealant is sufficiently cured so that it will not spread on the plate.

2 The highest precision in this test can be obtained when the durometer (see Fig. 2) is supported by a rigid stand and a dead weight is fastened directly to the instrument with the centre of gravity of the weight acting in line of the indenter point. A freely acting total deadweight load of approximately 12.5 ± 0.5 N has been found satisfactory for the testing of various sealants.

3 The values obtained in the test method described above are known as “instantaneous” values. Occasionally a purchaser may request “delayed” values such as these taken after a 5 s or 10 s delay. To obtain a delayed value, the same procedure is followed, except that the pressure foot is allowed to rest on the surface of the sealant under the fixed load for the additional time requested and a reading is taken at the specified time, for example, after 5 s, 10 s or other specified period. Delayed readings are taken in addition to the instantaneous reading. An instrument with a maximum reading hand is helpful in making such determinations.



FIG. 2 Automatic Shore A Hardness tester

B-4.2 Test for Hardness of Single-Component Sealants

B-4.2.1 Condition at least 250 g of compound for a minimum of 24 h at standard conditions before starting the test.

B-4.2.2 Centre the brass frame on the aluminium plate and fill the opening with a portion of the conditioned compound, striking the compound off flat with a straightedge. Lift the frame from the sealant after separating it by running a thin-bladed knife along the inside edge of the frame. Two such specimens shall be prepared.

B-4.2.3 Cure the test specimens for a total of 21 days.

B-4.2.4 At the end of the 21 day curing period, proceed as described in **B-4.1.3** (see Notes 2 and 3).

NOTE — The manufacturer may request combinations of temperature and relative humidity for curing purposes other than those specified provided that:

- a) the curing period is no longer than 21 days; and
- b) the temperature does not exceed 50 °C.

B-5 Alternately, the measurement can be taken on the samples both single and multi-component sealant after 7 days of cure at standard condition; and shall meet the requirement as per the Table 1.

NOTE — The manufacturer may request combinations of temperature and relative humidity for curing purposes other than those specified provided that:

- a) the curing period is no longer than 21 days; and
- b) the temperature does not exceed 50 °C.

ANNEX C

[Table 1, Sl No. (iii)]

STANDARD TEST METHOD FOR EFFECTS OF HEAT AGING ON WEIGHT LOSS, CRACKING, AND CHALKING OF ELASTOMERIC SEALANTS AFTER CURE

C-1 GENERAL

This test method covers a laboratory procedure for determining the effects of heat aging on weight loss, cracking, and chalking of elastomeric joint sealants (single and multi-component) for use in building construction.

C-2 SUMMARY OF TEST METHOD

Sealant is spread on three aluminium panels and the net weight of sealant on each panel is determined. After the three sealant specimens are allowed to cure for 28 days at standard conditions, two specimens are then heat-aged for 21 days in a forced-draft oven maintained at 70 ± 2 °C. The percentage weight lost during the heat aging period is then determined and examination is made for presence of cracks and chalking.

C-3 SIGNIFICANCE AND USE

Weight loss from a sealant after application in a building joint can be detrimental to long term sealant durability. A sealant's service life will be shortened if it contains components, critical to its durability, that are volatilized by high environmental temperatures. Also, development of cracks and chalking lessens a sealant's service life. The test described herein measures weight loss, cracking, and chalking. The amount of weight lost during the heat aging period and any cracking or chalking helps predict premature sealant failure. However, a sealant developing no cracks or chalking, or low weight loss in this test, does not necessarily ensure good durability.

C-4 APPARATUS REQUIRED

C-4.1 Forced-draft oven, controlled at $70 \text{ °C} \pm 2 \text{ °C}$.

C-4.2 Balance, sensitive to 0.01 g.

C-4.3 Rectangular brass/aluminium or TFE-fluorocarbon frame, with inside dimensions $130 (\pm 5 \text{ mm}) \times 40 (\pm 5 \text{ mm}) \times 3 (\pm 0.5 \text{ mm})$

C-4.4 Aluminium panels, three, each $150 (\pm 5 \text{ mm}) \times 80 (\pm 5 \text{ mm}) \times 0.6 \text{ mm}$ to 1.6 mm.

C-4.5 Straight edge, metal or plastic, about $150 \pm 5 \text{ mm}$ long.

C-4.6 Thin knife blade.

C-4.7 Spatula, steel, about 150 mm long.

C-5 PROCEDURE

Unless otherwise specified by those authorizing the test, standard conditions shall be used.

C-6 TEST OF MULTICOMPONENT SEALANTS

C-6.1 Condition at least 400 g of base compound and appropriate amount of curing agent in closed containers for at least 24 h at standard conditions; then mix thoroughly together for five minutes. Alternatively, metering and mixing equipment installed in the same environment with the material can also be used to get homogeneous mix of the sealant for the test. Weigh each of the three aluminium panels to the nearest 0.01 g. Centre the brass frame on an aluminium panel. Fill the frame with the mixed compound and strike it off flat with the straightedge. Run a thin-bladed knife along the inside of the frame to separate it from the sealant and immediately lift the frame from the sealant. Prepare two more specimens the same way.

C-6.2 Cure the three specimens for 28 days at standard conditions. At the end of the 28 day cure period, weigh each specimen to the nearest 0.01 g.

C-6.3 Place two of the three specimens in the forced-draft oven at 70 ± 2 °C for 21 days, leaving the third (control) specimen at standard conditions for the same period. At the end of the 21 day heat-aging period, remove the specimens from the oven and allow them to cool for 1 h at standard conditions. Then weigh each specimen to the nearest 0.01 g and calculate the percent weight loss during heat aging as follows:

$$\text{percent } WL_{ha} = \frac{(W_2 - W_3)}{(W_2 - W_1)} \times 100$$

where,

WL_{ha} = weight loss from cured sealant during heat aging;

W_2 = weight of panel and sealant after the 28 day cure period;

W_3 = weight of panel and sealant after 21 day heat-aging period; and

W_1 = weight of aluminium panel.

C-7 TEST OF SINGLE COMPONENT SEALANTS

Follow the same procedure as specified in **C-6.1** to **C-6.3**, eliminating curing agent and the mixing necessary for multicomponent sealants.

See Fig. 3 for reference on cracking of sealant.

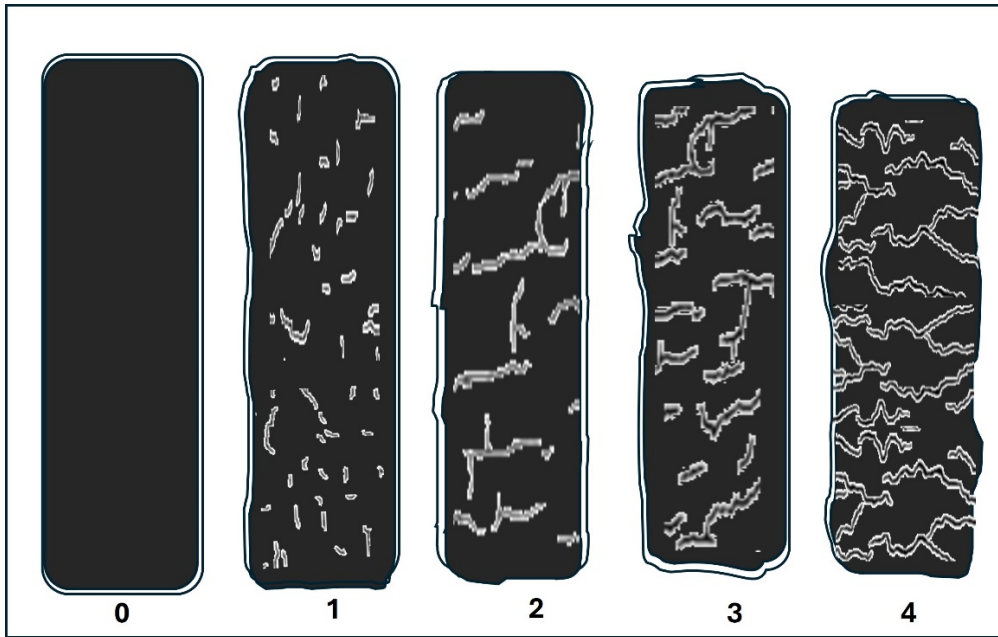

FIG. 3 EXAMPLES OF CRACKING OBTAINABLE IN THIS TEST.

NOTE — TEST NUMBER 0 IN THE FIGURE REPRESENT NO CRACKING AND LOSS IN MASS

ANNEX D

[Table 1, SI No. (iv)]

STANDARD TEST METHOD FOR SLUMP OF SEALANTS

D-1 GENERAL

This test method covers a laboratory procedure for the determination of the degree of slump of a sealant when used in a vertical joint in a structure.

D-2 TYPES

The scope of the methodology described below is applicable for NS grade sealant in both Type S and Type M.

D-3 SIGNIFICANCE AND USE

Excessive sealant slump or sag in a vertical joint may cause improper bead shape or inadequate sealant thickness in the completed joint. Slump measurements, as described in this test method, serve to evaluate only this application characteristic; they do not predict the performance capability of the sealant after installation.

D-4 APPARATUS REQUIRED

D-4.1 Jig — as per the drawing (see Fig. 4A, 4B and 4C)

D-4.2 Plastic/Metal Scraper

D-4.3 Timer

D-5 PROCEDURES

D-5.1 Sampling

Take test specimens from a previously unopened container and mix thoroughly before using, if required for homogeneity.

D-5.2 Cleaning

Clean the jig with methyl ethyl ketone or similar solvent.

D-5.3 Conditioning

Condition both the test jig and the sealant to be tested for at least 5 h at Standard laboratory condition

D-5.4 Procedure

Thoroughly clean the test jig with the solvent; then place it on a level table with the front face upward and the plunger depressed to the limit of its travel.

Place the mixed, conditioned sealant in the jig cavity. Level the sealant flush with the surface of the block, using one gentle upward stroke of the metal/plastic scraper held

at a 45° angle. Avoid forming air pockets in the sealant, especially near the surface of the plunger. Carefully clean the area around the cavity with the plastic scraper and a cloth. The loading operation should be completed within 2 min and with minimum amount of working of the sample.

Immediately set the jig in a vertical position and advance the plunger to the limit of its forward travel and start the timer. Allow the jig to stand undisturbed for 3 h (see Note). The sample will have flowed down the face of the jig. Record the point of furthest advance using graduated scale.

NOTE — If the material cures on exposure, the test may be stopped when the skin-over time has been exceeded by 5 minutes.

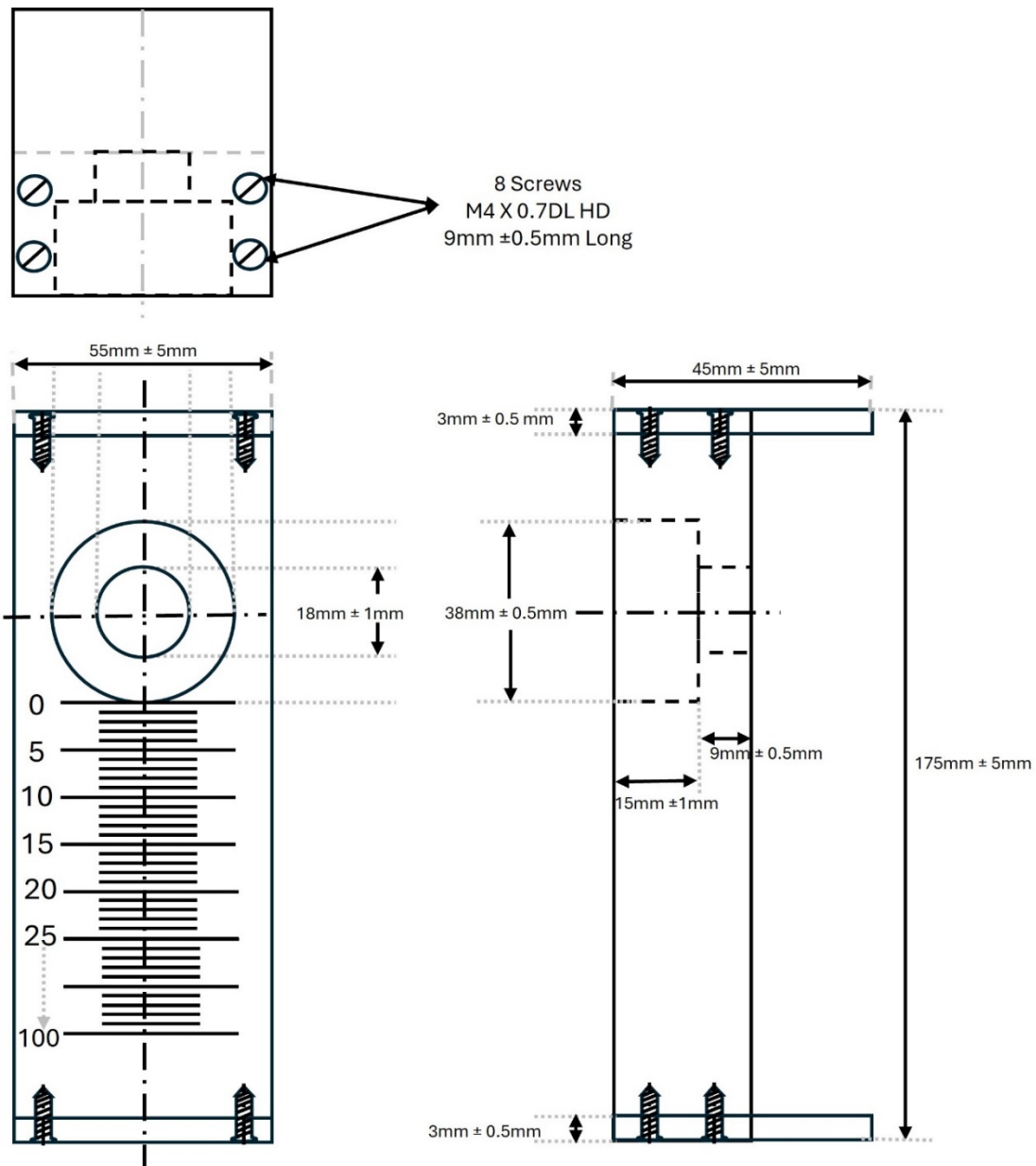

FIG. 4A FLOW TEST JIG

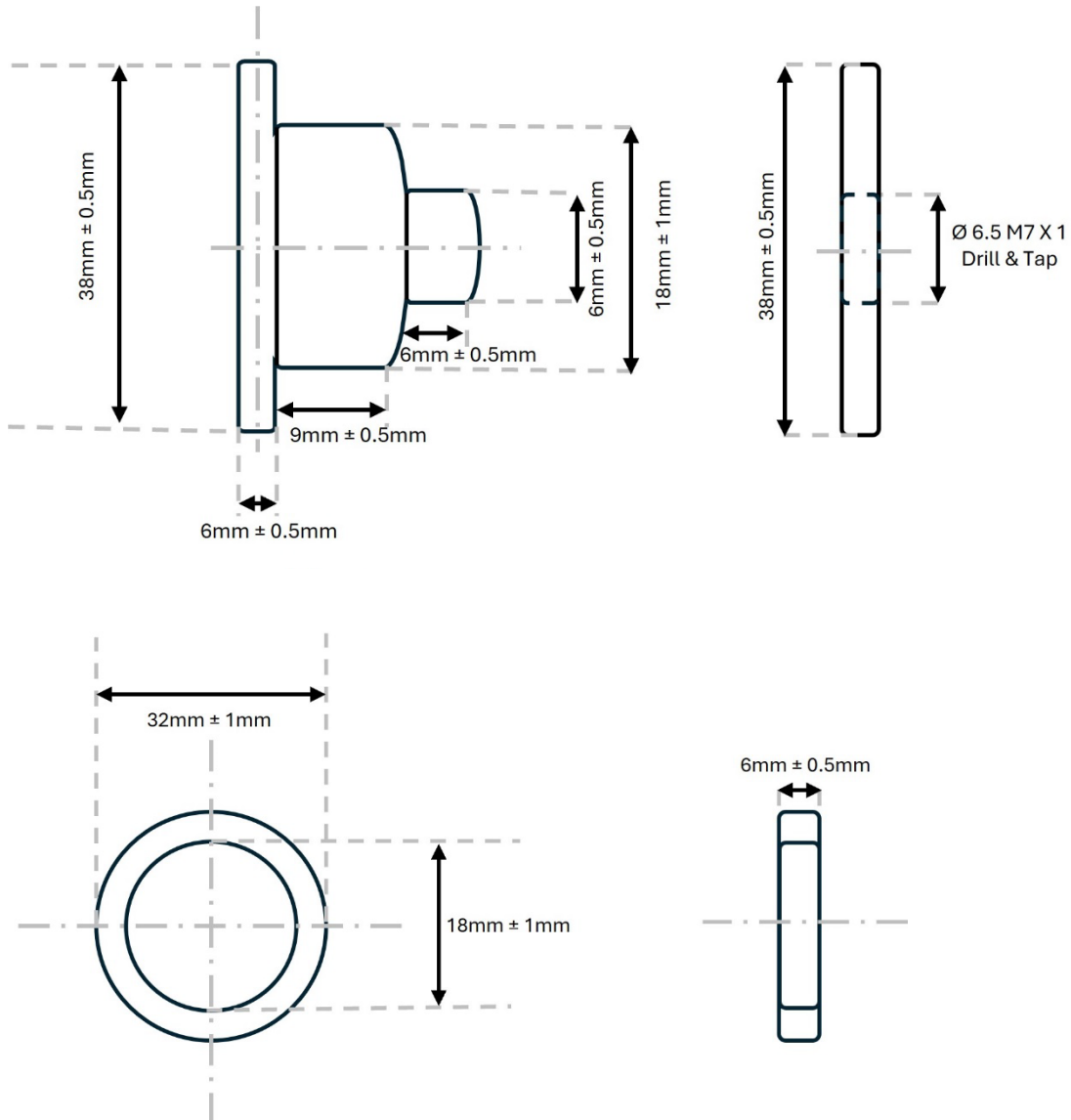

FIG. 4B PLUNGER & NUT

All dimensions in millimetres.

FIG. 4C WASHER

ANNEX E

[Table 1, SI No. (v)]

STANDARD TEST METHOD FOR TACK-FREE TIME OF ELASTOMERIC SEALANTS

E-1 GENERAL

This test method covers a procedure for the determination of the tack-free time property of single and multi-component elastomeric sealants commonly used for sealing caulking and glazing in buildings and related construction.

E-2 SIGNIFICANCE AND USE

E-2.1 The tack-free time is a measure of the surface cure time and may generally be correlated to a variety of useful parameters such as the time interval before the sealant:

- a) Resists damage by touch or light surface contact;
- b) Resists jobsite or airborne dirt pick-up; and
- c) Resists impinging rainfall.

E-2.2 The tack-free time is sometimes used as an on-the-job quality assurance test. A quality product that is consistent and reproducible will generally fall within a maximum and minimum tack-free time.

E-2.3 This test for tack-free time can be used at any temperature and humidity. It is important that if a sealant will be used in a climate quite different than the standard conditions called out in this test method, then those conditions be used to test the sealant.

E-3 APPARATUS

E-3.1 Cabinet or room, capable of maintaining standard laboratory conditions.

E-3.2 Weight, rectangular, with dimensions of $(40 \pm 1 \text{ mm}) \times (20 \pm 1 \text{ mm})$ and mass of $30 \pm 1 \text{ g}$

E-3.3 Timer, capable of measuring minutes and hours.

E-3.4 Rectangular plates, several (often 6 or more), rectangular, approximately $150 \times 75 \text{ mm}$ made of non-porous material such as tin-plated steel or aluminium. Alternatively, Cleaned and dried polyethylene sheet of 0.25 m^2 can be spread and taped firmly on to a Non-porous surface such as granite or metal table.

E-3.5 Template, rectangular, of steel, brass or other suitable material, about 3 mm thick with inside dimensions of approximately $95 \text{ mm} \times 25 \text{ mm}$; outside dimensions approximately $120 \text{ mm} \times 30 \text{ mm}$ or a tooling device with an indentation of 3 mm can be used.

E-4 SAMPLING

The test sample shall consist of a factory-sealed can of compound (minimum contents, 450 ml with an appropriate curing agent where applicable, or a standard cartridge, factory fill and sealed.

E-5 PROCEDURE

E-5.1 Thoroughly clean the templates and rectangular plates with methyl ethyl ketone, xylene, or similar solvent.

WARNING — Methyl ethyl ketone, xylene, and similar solvents are both toxic and flammable and should be handled with caution in a well-ventilated hood.

E-5.2 Condition the sample of sealant in the original closed container for 24 h at standard conditions. For single-component sealants, weigh out approximately 250 g of the sealant before testing. For multi-component sealants, thoroughly mix 250 g of the base compound with the appropriate amount of curing agent following the manufacturer's mixing instructions.

E-5.3 Prepare at least two specimens for each sealant as follows:

Centre the template on the metal plate and carefully fill it with sealant avoiding air pockets. Strike off the surface flat using a metal straightedge, to a uniform thickness.

E-5.4 Relative Tack-Free Time Unknown

If the relative tack free time is unknown, the procedure is to pre-test one of the test specimens by lightly touching the surface of the sealant with a film of polyethylene wrapped over the end of a finger. Touch the test piece in accordance with an appropriate time interval described in **E-5.5**. Try to touch a different place on the surface each time. After the polyethylene wrapped finger is lightly touched to the surface of the sealant, it is immediately removed and examined to see if sealant was picked up on the polyethylene film when no sealant is picked up on the polyethylene strip, perform the next test as described in **E-5.6**.

E-5.5 Time Intervals

If the relative tack-free time is unknown, the procedure is to pre-test, as in **E-5.4**, one test specimen each minute for the first 10 min, each 2 min for the next 10 min, each 5 min for the next 160 min (3 h has elapsed), each hour for the next 69 h, each day until a positive result is achieved or until 21 days has elapsed. Below table summarizes the time intervals.

E-5.6 After the pre-test in **E-5.4** do the actual test by starting new, but just before the tack-free time estimated by the pre-test. At the appropriate time lay a polyethylene strip over half of the same test specimen and gently place the brass weight on the strip and allow it to remain there for $4 \text{ s} \pm 2 \text{ s}$.

E-5.7 Remove the weight and then slowly withdraw the polyethylene strip pulling it

with thumb and forefinger at 90° to the compound, at a constant rate of 25 mm/15 s (see Fig. 5).

E-5.8 If the strip is clean or almost clean, repeat the test of **E-5.6** and **E-5.7** on a previously undisturbed test specimen. If the strip is clean from the previously undisturbed test specimen, record the time from the moment the template was scraped level with a spatula until the pulling of this strip.

E-5.9 If the polyethylene strip still has sealant adhering to it, wait half the time of the preceding test time interval and repeat the test described in **E-5.6** and **E-5.7** on another undisturbed test piece.

E-5.10 If the strip is again not clean, repeat **E-5.9** until a clean strip is achieved.

E-5.11 If an approximate tack-free time is known, consult the below table and choose the total elapsed time interval that matches the supposed tack-free time, back down one interval and start the process there and proceed with the pre-test and test as described above.

E-5.12 If the tack-free time is shorter than anticipated, start with fresh specimens and pick a shorter elapsed time as the starting point.

E-5.13 If the tack-free time occurred at an occasion when no one was available to check it (that is, night or weekend) start the test over, at such a time where the anticipated final point will occur during working hours.

NOTE — Certain test conditions seem to have a particularly large influence on the accuracy of this test and therefore, should be closely watched of prime importance is performing the test at the called-out conditions.

	For first 10 min test each minute	For next 10 min test each 2 minutes	For next 160 min test each 5 minutes	For next 69 h test each hour	For next 18 days test each day
Total time elapsed	10 min	20 min	3 h	3 days	21 days

E-6 ALTERNATE PROCEDURE

Spread the sealant sample 3 ± 0.8 mm thick on the polyethylene sheet taped to a non-porous substrate, using the tooling device. The surface area should be at least 300 mm². Start the timer at once. At intervals of 5 min or less lay a clean polyethylene strip on a fresh surface and gently set 30 ± 2 g weight on the strip, leave it for 4 s (+ 2 s, - 0 s), and remove it, gently. Pull the strip straight up, from one end, or as specified. Record and report the time when the strip pulls away cleanly from the sample.

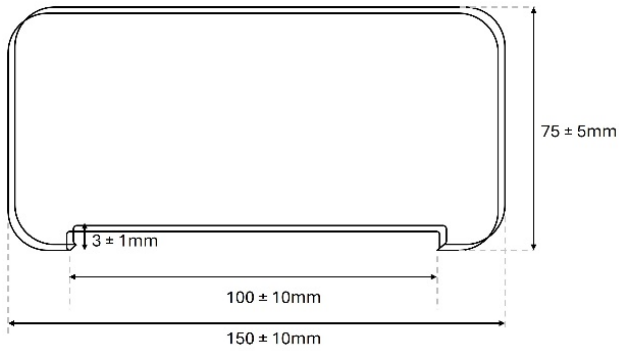

FIG 5 (A) TOOLING DEVICE

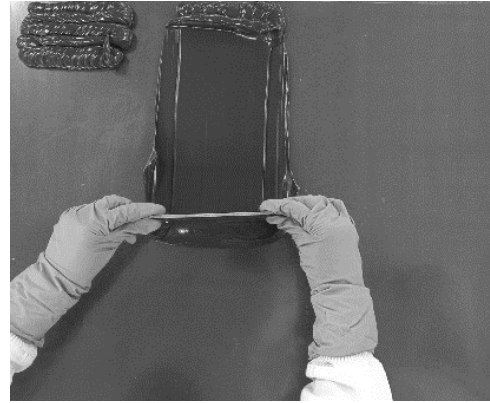

FIG 5 (B) CAULKING AND SPREADING OF THE SEALANT USING TOOLING DEVICE

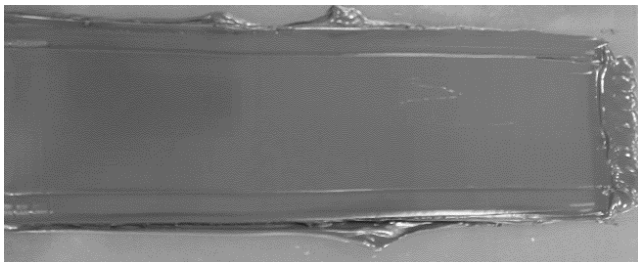

FIG 5 (C) TOOLED SEALANT

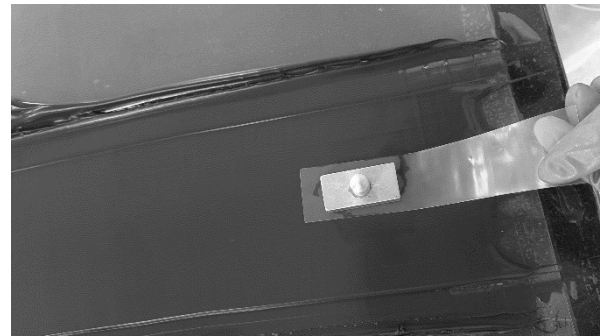

FIG 5(D) CHECKING OF TACK FREE TIME BY PLACING THE WEIGHT ON TOP OF THE POLYETHYLENE SHEET PLACED ON THE SEALANT

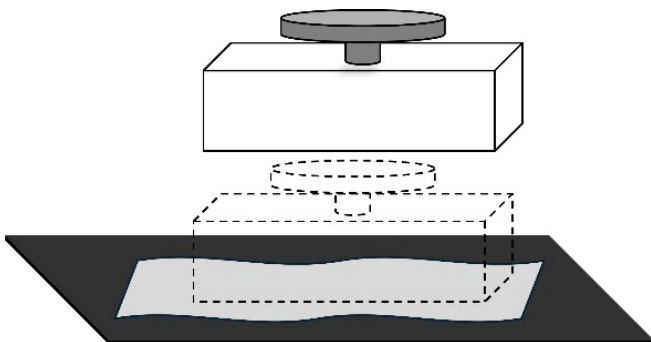

FIG 5(E) EXERTING CONSTANT LOAD ON SEALANT BY PLACING THE WEIGHT ON TOP OF THE POLYETHYLENE SHEET

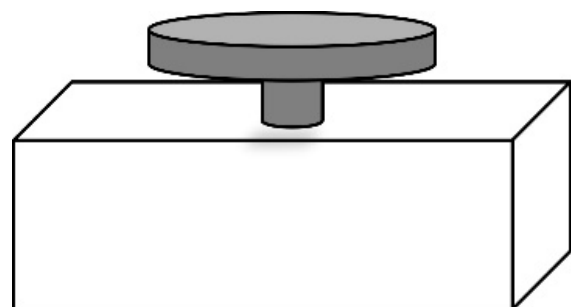

FIG 5(F) WEIGHT 30G±2G

PLACED ON THE SEALANT

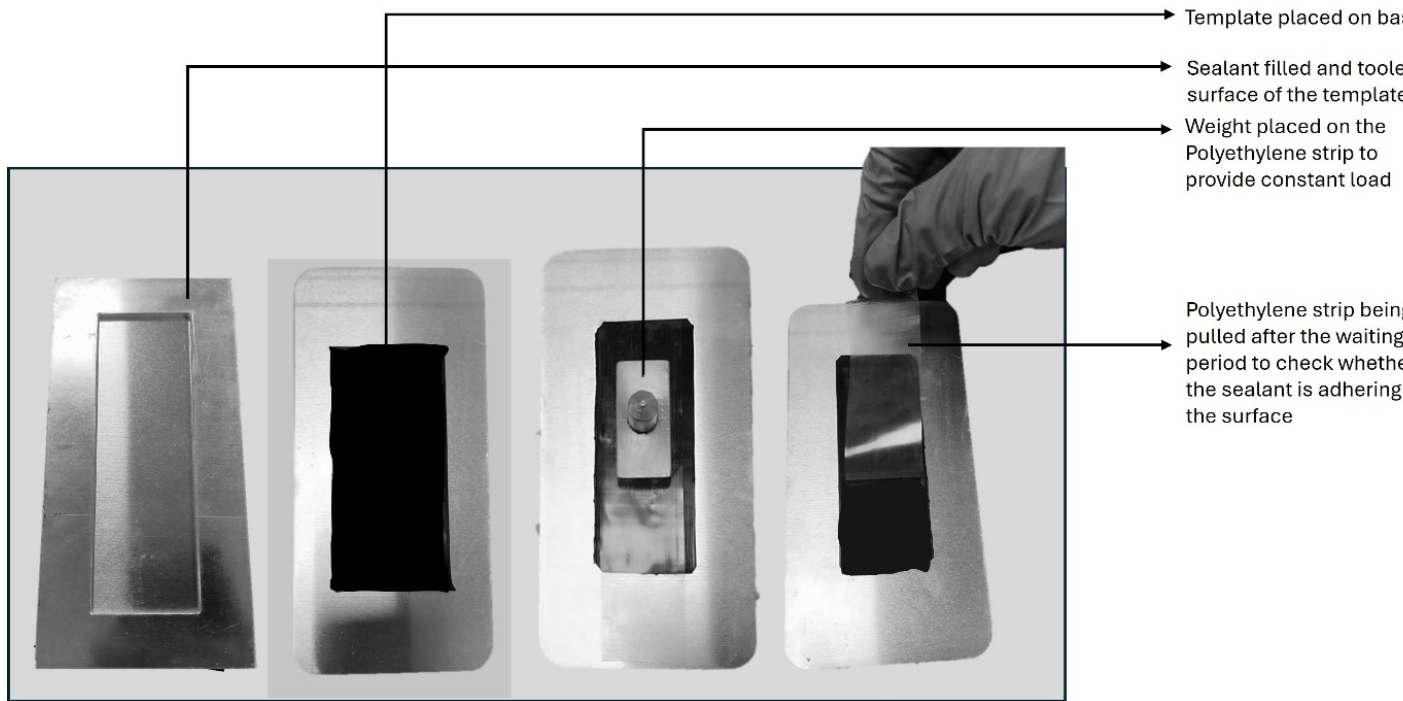

FIG. 5 STAGES IN THE TACK-FREE TIME TEST PROCEDURE

ANNEX F

[Table 1, SI No. (vi) and Annex J]

STANDARD TEST METHOD FOR ADHESION-IN-PEEL OF ELASTOMERIC JOINT SEALANTS

F-1 GENERAL

This test method covers a laboratory procedure for determining the strength and characteristics of the peel properties of a cured-in-place elastomeric joint sealant, single-component or multi-component, for use in building construction.

F-2 SUMMARY OF TEST METHOD

This test method consists of preparing test specimens by embedding a wire mesh screen between two thin layers of the sealant being tested, on test substrates, curing these specimens under specified time and conditions, then placing the specimen in a tension-testing machine in such a way that the embedded wire mesh screen is peeled back from the substrate at 180°, while measuring the force exerted as well as the mode of failure of the sealant from the substrate.

F-3 SIGNIFICANCE AND USE

This test provides a valuable measurement of the ability of the cured sealant to maintain a bond to the substrate under severe peel conditions. This test is especially useful for quality measurements comparing batches of the same sealant relative to adhesion or for studying adhesion of a given sealant to a variety of substrates.

This test method alone is not appropriate for comparing the overall performance of different sealants in a given application. The adhesive force that determines if a given sealant is useful in a given application also depends on the modulus of elasticity and the degree to which the sealant will be strained.

This test, as it exists, does not consider the modulus of elasticity, nor amount of stress that will be produced by a given strain in an actual sealant in a moving joint. No known correlations are given to relate and apply modulus values to the peel values.

This test requires that the results indicate whether the failure mode is primarily adhesive or cohesive.

F-4 APPARATUS AND MATERIALS REQUIRED

F-4.1 Tensile testing machine with tension grips capable of pulling at the rate of separation of approximately 50 mm/min \pm 5mm/min, and having a chart indicator calibrated in 0.45 N units.

F-4.2 Standard Substrates

This test method may be performed on a wide variety of substrates. Since adhesive properties of a joint sealant are related to the nature of the substrate, it is strongly

recommended that whenever possible that adhesion-in-peel testing be performed on substrate samples that are representative of the building materials. Examples of such substrates include brick, marble, limestone, granite, aluminium, stainless steel, plastic, ceramic tile, and others.

F-4.3 Masking tape, paper, roll, 25 ± 5 mm wide.

F-4.4 Wire mesh screen, stainless steel or aluminium, 20 mesh, $0.4 \text{ mm} \pm 0.1 \text{ mm}$ wire thickness, cut to a width of 25 mm (+ 0 mm, - 2 mm) by a minimum length of $250 \text{ mm} \pm 5 \text{ mm}$. Alternatively, $12 \text{ mm} \pm 1 \text{ mm}$ width wire mesh can also be used to evaluate the substrate in the testing.

F-4.5 The wire mesh screen selected must be flexible yet strong enough to not tear during adhesion-in-peel testing. The wire mesh screen must be flat and free of kinks. To ensure adhesion of the joint sealant to the wire mesh, thoroughly clean the screen prior to use. Sealant primer on the wire mesh screen is generally recommended by the sealant manufacturer to enhance adhesion of the joint sealant to the screen. Sealant may also be pre-applied to the screen to enhance adhesion.

F-4.6 Discussion

Adhesion of the joint sealant to the mesh screen is essential to evaluate adhesion-in-peel properties of the sealant to the substrate. Due to the unique characteristics of each sealant, the sealant manufacturer must determine for each sealant the appropriate screen composition, mesh dimensions, wire diameter and screen cleaning and priming procedure.

Polyester mesh, fiberglass mesh, airplane cloth, fabric, plastically or similar material can be used in lieu of a wire mesh provided that the material is pliable, of a thickness no greater than 0.5 mm, does not adversely affect sealant cure and does not rupture during adhesion-in-peel testing.

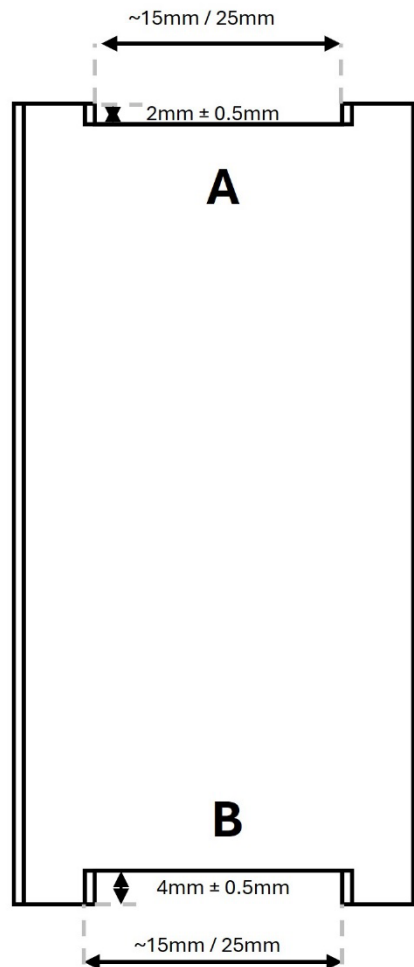

Key

A - 15 mm/25 mm × 2 mm indentation

B - 15 mm/25 mm × 4 mm indentation

FIG. 6 SPECIAL TOOLING DEVICE

F-4.7 Tooling Device

Aluminium or similar rigid material, created to produce a 2 mm (± 0.1 mm) × 25 mm (± 1 mm) sealant bead and 4 mm (± 1 mm) × 25 mm (± 1 mm) sealant bead after tooling (see Fig. 6). The width of the tooling device may be up to 28 mm ± 2 mm to allow easy tooling of the sealant without snagging the edges of the screen.

F-4.8 Putty knife, rigid, approximately 40 mm wide.

F-4.9 Knife, with sharp razor-type blade.

F-5 TEST SPECIMENS AND CURE PROCEDURES (SEE FIG. 7)

F-5.1 Four test specimens (adhesion-in-peel samples) shall be prepared on each of the substrates using the following procedures condition a minimum of 250 g of sealant for 24 h at standard conditions. Multi-component sealants will require mixing for 5 min

or as recommended by the sealant manufacturer. Specific mixing equipment and mixing procedures may be recommended by the sealant manufacturer. Alternatively, metering & mixing equipment installed in the same environment with the material can also be used to get homogeneous mix of the sealant for the test.

F-5.2 Clean and prepare the substrate samples in accordance with the sealant manufacturer's recommendations.

F-5.3 Apply primer(s) to the substrate(s) if recommended by the sealant manufacturer.

F-5.4 Masking tape can be applied to the substrate surfaces adjacent to the test area to allow easy removal of excess joint sealant.

F-5.5 Wire mesh screens must be thoroughly cleaned and primed, if required, as recommended by the sealant manufacturer.

F-5.6 For each substrate preparation/cleaning condition to be tested, apply a bead of sealant at least 100 mm~250mm in length to the substrate surface.

F-5.7 Immediately place the wire mesh screen on the sealant bead and lightly tap it into the joint sealant.

F-5.8 Holding the screen with a finger to prevent slippage, gently draw down the sealant imbedding the wire mesh into the wet sealant, using the special tooling device (Side A) at an 90° angle to the substrate. The wire mesh screen should be imbedded to a uniform depth of 2 mm from the substrate surface.

F-5.9 Immediately apply a second bead of joint sealant over the first bead of sealant and wire mesh screen.

F-5.10 Again, holding down the screen with a finger to prevent slippage, use the special tooling device (Side B) and draw down the sealant at a 90° angle to the substrate. The total depth of the sealant should be 4 mm and the wire mesh screen should be imbedded uniformly at the approximate midpoint of the total sealant depth.

F-5.11 Excess sealant beyond the edge of the wire mesh screen may be removed while the sealant is wet using a putty knife or spatula. Avoid moving the screen imbedded in the sealant. Masking tape, if used, should be removed at this time.

F-5.12 After the sealant is cured, excess sealant may be carefully removed along the length of the test sample using a razor knife. Fig. 7(g) shows a final prepared adhesion-in-peel test samples.

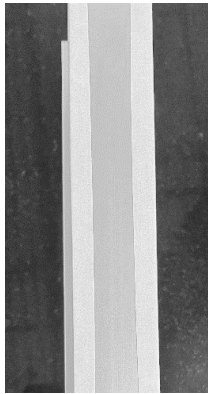

a) CLEANED AND PREPARED SAMPLE WITH MAKING TAPE



b) APPLICATION OF PRIMER TO THE SAMPLE



c) FIRST SEALANT BEAD APPLIED TO SUBSTRATE (WITH MASKING TAPE)



d) WIRE MESS SCREEN BEING IMBEDDED IN WET SEALANT BEAD

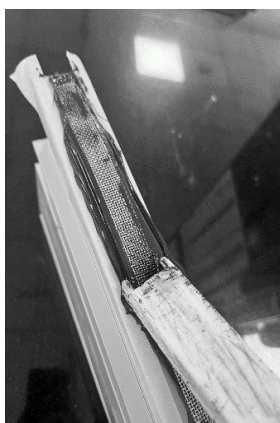

e) TOOLING SEALANT AFTER IMBEDDING WIRE SCREEN MESH WITH SPECIAL TOOLING DEVICE — SIDE A

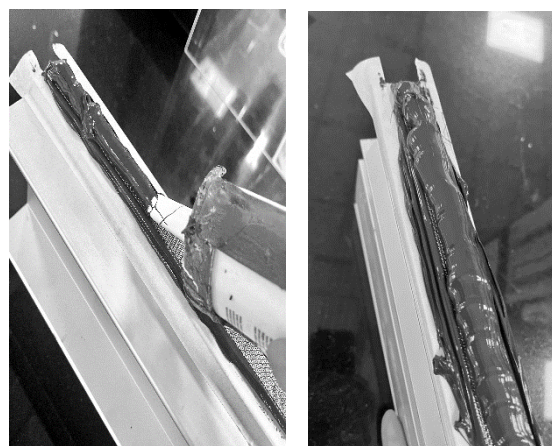

f) SECOND SEALANT BEAD APPLIED TO SUBSTRATE (WITH MASKING TAPE)



g) TOOLING SECOND BEAD OF SEALANT
WITH SPECIAL TOOLING DEVICE — SIDE B

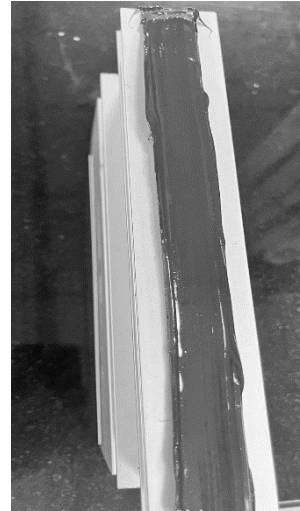

h) FINISHED ADHESION-IN-PEEL TEST
SAMPLES (WITHOUT MASKING TAPE)

FIG. 7 TEST SPECIMENS AND CURE PROCEDURES

F-5.13 Allow the sealant to cure as recommended by the sealant manufacturer. Standard curing time is 21 days at standard conditions. Curing time and conditions may vary depending on the sealant type and application.

NOTE — The producer may request conditions other than those specified in **F-5.13** for the curing period of single-component sealants provided they meet the following requirements:

- a) The curing period shall extend for 21 days; and
- b) The temperature during the curing period shall not exceed 50 °C.

F-6 TEST PROCEDURE

F-6.1 Once the sealant is fully cured, gently wrap the loose end of the wire mesh screen and bend back. Using a razor knife, provide a fresh cut along the sealant to the substrate interface (see Fig. 8).

F-6.2 Place the test specimen in the tensile testing machine with the substrate secured to the fixed member and the loose end of the wire mesh screen secured to the movable member at an angle of 180° (see Fig. 9).

F-6.3 Pull the screen at a rate of 50 mm/min \pm 5mm/min for a total of 1 min.

F-6.3.1 If the screen breaks during the testing, disregard the value. If possible, undercut the sealant with a razor knife and repeat the test. If the screen continues to break, prepare new test samples using a higher strength wire mesh screen.

F-6.3.2 If the sealant peels away cleanly from the screen, disregard the value. Undercut the sealant with the razor knife and repeat the test. If adhesive failure to the screen continues, prepare new test samples using a more thoroughly cleaned or

primed, or both, wire mesh screen. If necessary, use a material other than a wire mesh screen.

F-6.3.3 If the adhesion-in-peel test sample shows adhesive failure to the screen in two repeated attempts but peel force values are above the specified requirements, further sample testing may not be required. In such cases, report failure mode as screen delamination, since adhesive or cohesive failure of the sealant to the substrate is not fully established. The screen should be pulled for a total of 1 min as described in **F-6.3**.

NOTE — Discussion some sealants may have a non-homogeneous mode of failure during the initial adhesion-in-peel testing. During the first 30 s to 60 s of testing, the sealant may achieve a steady state and longer test duration may be needed to accurately assess the failure mode of the sealant.

F-6.3.4 Record the peak force in newton (pound force).

F-6.3.5 Observe and record the approximate percentages of sealant failure modes over the total test area. Sealant failure is described as either adhesive or cohesive failure. See Fig. 11 for an example of each failure mode. Failure observed within the substrate (that is, paint removal, etc) should be reported as substrate failure.

F- 6.4 Water Immersion Test

Using either four separate test specimens or the same test specimen used for dry adhesion testing and following completion of standard cure as described in **F-5.12** immerse the test samples for 7 days in distilled water conditioned to $23\text{ }^{\circ}\text{C} \pm 2\text{ }^{\circ}\text{C}$. Mortar and concrete specimen should be placed in a separate container from glass and aluminium specimen because the high alkali condition generated could have an adverse effect on the glass and aluminium.

Following water immersion, remove the test samples, lightly dry with a cloth or paper towel and test within 10 min as described in **F-6.1** through **F-6.3.5**.

F-6.5 Additional conditions may be used including different cure conditions, different water temperature or duration of immersion, exposure of sealant to chemicals or other materials or exposure to ultraviolet radiation, heat, or weathering.

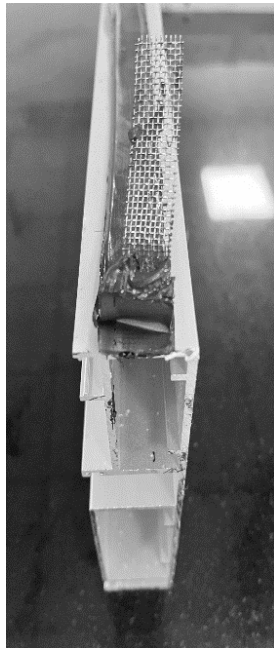
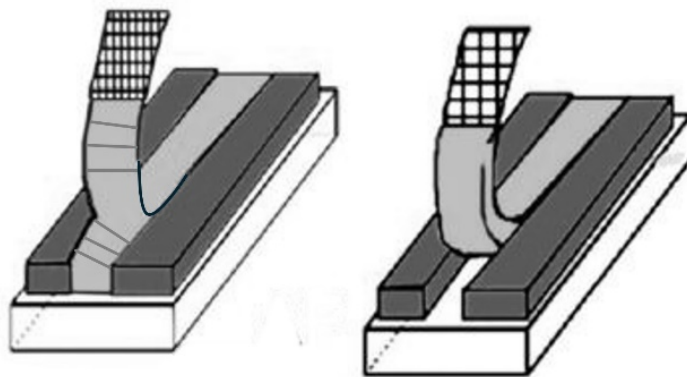

FIG. 8 CUT ALONG SEALANT/SUBSTRATE
INTERFACE



FIG. 9 ADHESION-IN-PEEL TEST SPECIMEN
SECURED IN TENSILE MACHINE



Key

LEFT – COHESIVE FAILURE,

RIGHT – ADHESIVE FAILURE

FIG.10 ILLUSTRATION OF COHESIVE FAILURE AND ADHESIVE FAILURE

ANNEX G

[Table 1, SI No. (viii)]

STANDARD TEST METHOD FOR DETERMINING COMPATIBILITY WITH ACCESSORIES USED IN STRUCTURAL GLAZING SYSTEMS

G-1 GENERAL

This test method covers a laboratory screening procedure for determining the compatibility of liquid-applied structural sealant glazing sealants when in contact with accessories such as dry glazing gaskets, spacers, shims, and setting blocks after exposure to heat and ultraviolet light.

This test method includes the observation of three parameters as follows:

- a) Changes in the colour of the sealant;
- b) Changes in the adhesion of the sealant to glass; and
- c) Changes in the adhesion of the sealant to the accessory being tested.

G-2 SIGNIFICANCE AND USE

In structural sealant glazing systems, the sealant functions as the structural adhesive and may also function as the primary weather seal. As the structural adhesive, the integrity of the adhesive bond is critical.

Changes in colour and adhesion after exposure are two of the criteria that can be used to determine the compatibility of the system. Experience has shown that accessories that cause loss of adhesion or discolouration in this test method may also cause these occurrences in actual use.

G-3 APPARATUS AND MATERIALS

G-3.1 Glass panels, clear float glass, approximately 75 mm (± 5 mm) \times 50 mm (± 5 mm) \times 6 mm (± 0.5 mm), Eight panels are required for each material being tested.

G-3.2 Bond breaker tape, 25 mm (± 1 mm) \times 75 mm (± 5 mm) piece for each panel. The bond breaker tape must be compatible with the sealants being tested.

G-3.3 Thermometer capable of measuring, 100 °C.

G-3.4 Ultraviolet (UV) lamps, UVA-340 lamps.

G-3.5 UV Exposure Apparatus

A suitable UV exposure apparatus will consist of four UVA-340 lamps in a symmetrical array situated 250 mm (± 5 mm) from the surface of the test specimens (see Fig. 13). The apparatus shall be capable of maintaining a temperature at the test specimens of 48 ± 2 °C. Infrared lamps or other sources of heat may be used to maintain the required temperature.

G-3.6 Cleaning Solvent

Any solvent capable of cleaning the glass is acceptable (for example, 50/50 mix of isopropyl alcohol and distilled water).

G-3.7 Test sealant, an appropriate amount of the sealant to be used in the system.

G-3.8 Reference Sealant

A light or translucent sealant of the same composition as the test sealant. If none is available, contact the sealant supplier for recommendations on a suitable alternative.

G-4 PREPARATION OF TEST SPECIMENS

G-4.1 Precondition the unopened containers of sealant at standard conditions for a minimum of 24 h.

G-4.2 Prior to use, clean the glass thoroughly with the cleaning solvent and dry with a clean rag before the solvent is allowed to evaporate.

G-4.3 Place a piece of compatible bond breaker tape to cover 25 mm of the top surface of the glass at one end (see Fig. 12).

G-4.4 Prepare a total of eight samples (four controls without accessory and four test specimens with accessory). Cut a piece of accessory material approximately 6 mm (± 1 mm) \times 50 mm (± 5 mm) \times 6 mm (± 1 mm) and place it on the centre of the piece of glass as shown in Fig. 12. Both the reference sealant and the test sealant are tested in contact with the accessory.

G-4.5 Apply a bead of the test sealant on one side of the accessory and a bead of translucent or light colour reference sealant along the other side of the accessory. Tool the sealant so that good contact with the glass occurs and the sealant is on top of the accessory. The thickness of the sealant on top of the accessory shall be approximately 3mm to 5mm

G-4.6 The control specimens for this test are prepared and tested identically to the test specimens except that the accessory is eliminated.

G-5 CONDITIONING

G-5.1 Condition all the specimens for one week at standard conditions. After conditioning for seven days at standard conditions, place two test specimens (with accessory) and two control specimens (without accessory) with glass side down, and place two test specimens (with accessory) and two control specimens (without accessory) with glass side up, under the UV lamps, in accordance with Fig. 11 (a) and Fig. 11 (b) for 21 days.

G-5.2 In order to provide an appropriate intensity of UV radiation; replace the UVA-340 lamps after eight weeks of use. In order to provide more uniform UV radiation, replace one lamp every two weeks, in accordance with the rotation scheme shown in Fig. 14.

(Discard lamp No. 3, move lamp No. 2 to lamp position No. 3, move lamp No. 1 to lamp position No. 2, move lamp No. 4 to lamp position No. 1 then install the new lamp in lamp position No. 4.).

G-5.3 The test chamber shall maintain an air temperature of $48\text{ }^{\circ}\text{C} \pm 2\text{ }^{\circ}\text{C}$ when measured at the surface of the test specimens (see Fig. 14). Check test specimen surface temperatures at one-week intervals.

G-6 PROCEDURE

G-6.1 Record orientation of sample under ultraviolet lights (see Fig. 11).

G-6.2 At the end of the conditioning period described in G-3, remove the specimens from the exposure apparatus and allow the warm samples to reach room temperature. (Cool for 4 h).

G-6.3 Grasp the end of the sealant that is above the bond breaker tape. Pull the sample on a 90° angle to the glass surface exerting force on the sealant/glass interface.

G-6.3.1 Record the mode of failure in percent cohesive failure, C , for both the test and reference sealant as follows:

$$C = 100 - \text{percent } AL$$

where,

AL = the adhesion loss.

G-6.4 Check the adhesion of the sealants to the accessory. Pull the sealant on a 90° angle to the accessory surface exerting force on the sealant accessory interface.

Record the mode of failure in percent cohesive failure (C).

G-6.5 Observe the test and reference sealant.

G-6.5.1 Using Table 2 as a guide, record and describe any colour change in the test and reference sealants.

G-6.5.2 Record any other noticeable changes.

Table 2 Stain and Colour Change Descriptions

(Clause G-6.5.1)

SI No.	Colour Change	Change Description
(1)	(2)	(3)
i)	None	No change from the control

ii)	Very very slight	Change so slight that you are not sure it is real
iii)	Very slight	Faint colour — Generally yellow
iv)	Slight	Light colour — Commonly yellow, orange, pink, or brown
v)	Severe	Distinct colour — Possibly red or purple in addition to yellow, orange, pink, or brown
vi)	Very severe	Dark colour — May be black as well as other colours mentioned

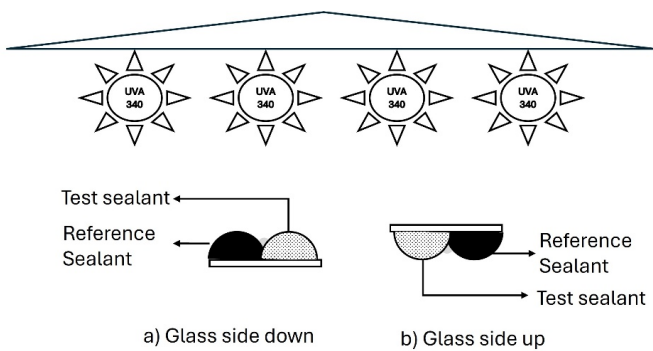

FIG. 11 ORIENTATION OF TEST SPECIMEN

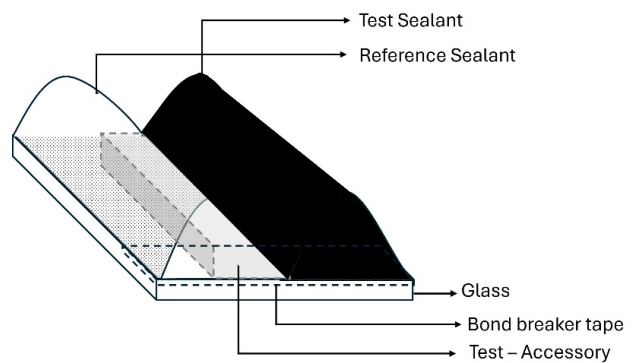

FIG. 12 VIEW OF TEST UNDER LAMPS SPECIMEN

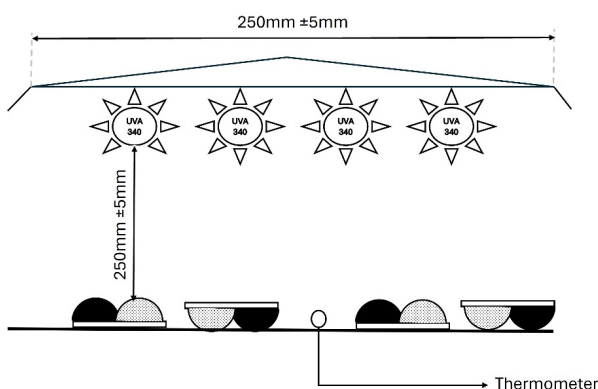

FIG. 13 UV EXPOSURE APPARATUS

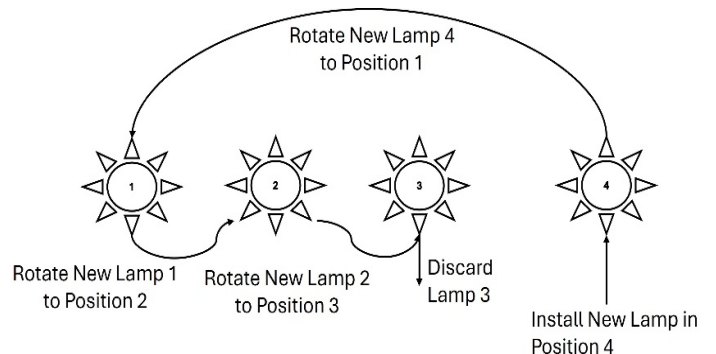

FIG. 14 UV LAMP ROTATION

ANNEX H

[Table 1, SI No. (x) and Annex J]

STANDARD TEST METHOD FOR DETERMINING TENSILE ADHESION PROPERTIES OF STRUCTURAL SEALANTS AT STANDARD LABORATORY CONDITION

H-1 GENERAL

This test method covers a laboratory procedure for quantitatively measuring the tensile adhesion properties of structural sealants.

H-2 SIGNIFICANCE AND USE

Frequently, glass or other glazing or panel materials are structurally adhered with a sealant to a metal framing system. The sealants used for these applications are designed to provide a structural link between the glazing or panel and the framing system.

H-3 APPARATUS AND MATERIALS

H-3.1 Tensile testing machine, capable of producing a tensile load on the specimen at the rate of 50 mm/min \pm 5 mm/min

H-3.1.1 *Fixed Member*

A fixed or essentially stationary member carrying one grip.

H-3.1.2 *Movable Member*

A movable member carrying a second grip.

H-3.1.3 *Grips*

The grips should be suitable to firmly grasp the test fixture that holds the test specimen and should be designed to eliminate eccentric specimen loading. Specimen loading should be perpendicular to the substrate/sealant inter-faces. For alignment purposes, each grip shall have a swivel or universal joint at the end nearest to the specimen.

H-3.1.4 *Grip Fixture*

A fixture capable of being held by the grips and furnishing a tensile force to the sealant specimen.

H-3.2 Spatulas, for use in applying sealant.

H-3.3 Caulking gun, for extruding sealant from cartridges when applicable.

H-3.4 Substrate Panels — two substrates of the same finish are required for each test specimen.

H-3.5 Spacer

One piece spacer made from polytetrafluoroethylene (PTFE) or a suitable rigid material shall be used to which the test sealant will not bond.

H-3.6 Substrate cleaning materials, primer (if needed).

NOTES

1 This test method is based on identical substrates of 6 mm × 25 mm × 75 mm (± 1mm) clear float glass. Other substrates may be tested; however, consideration needs to be given to maintaining adequate rigidity of the substrates during testing.

2 The precision and bias statement is based on glass substrates with a recommended cleaning solution of a 50 to 50 ratio isopropanol.

H-4 TEST SPECIMEN

H-4.1 Assembly

H-4.1.1 Prior to assembly, wipe the substrates with a clean, dry, lint-free cloth, then thoroughly clean with a solution appropriate for the substrate material. Prior to evaporation of the cleaning solution, wipe the substrates dry with a clean, lint-free cloth.

H-4.1.2 Apply recommended primer, if required. Then, construct the test specimen assemblies by forming a sealant cavity 12 mm × 12 mm × 50 mm (±1 mm) between two substrate panels (see Fig. 15A, 15B, 15C and 16) with the aid of appropriate spacers.

H-4.2 Preparation of Test Assemblies

H-4.2.1 Prepare a set of five test specimen assemblies for each sealant and substrate combination being tested (see Fig. 15A, 15B, 15C and 16).

NOTE — Five test specimen assemblies should be prepared for each additional environmental condition being evaluated.

H-4.2.2 Fill each set of five assemblies with the sealant being tested. Immediately tool the sealant surface to ensure complete filling and wetting of the substrate surfaces. Take special care to strike off the sealant flus with the substrate.

H-4.3 Labelling

Each of the five specimens of each set should be individually identified.

H-5 CONDITIONING

Cure the specimens for 21 days at standard conditions. Any deviations from the curing conditions must be listed in the report. Remove all spacer sections from the specimens. If desired, spacers may be removed prior to the end of the 21 day cure. If removed early, note this in the report.

- a) Condition five specimens for 1 h at 88 ± 2 °C in a forced air oven. Test the specimens at 88 ± 2 °C.

- b) Condition five specimens for 1 h at $-29\text{ }^{\circ}\text{C} \pm 2\text{ }^{\circ}\text{C}$. Test the specimens at $-29\text{ }^{\circ}\text{C} \pm 2\text{ }^{\circ}\text{C}$
- c) Immerse five specimens in deionized or distilled water at standard temperature for seven days. Test the specimens at standard conditions within 10 min after their removal from the water.
- d) Expose five specimens to artificial weathering following H-8 for a minimum of 5000 h.

H-6 PROCEDURE

H-6.1 Pull all specimens on the tensile test machine at standard conditions at a rate of 50mm per minute. If an analog chart recording device is being used, the chart speed should be a minimum of 127 mm per minute (508 mm per minute is preferred) to allow for a more accurate reading of force at specific elongations. Measure and record to the nearest 0.8 mm the actual minimum length (dimension A) and minimum width (dimension B), in millimetres as shown in (see Fig. 15A, Fig. 15B, Fig. 15C and Fig. 16). Record the tensile load, C, (see Note), newton's at 10 percent, 25 percent, 50 percent, and 100 percent strain, and percent strain at peak load. Measure and record percent cohesive failure along with test anomalies such as substrate breakage.

NOTE — If the substrate breaks, disregard the value at which it breaks. Other values obtained prior to breakage are acceptable.

H-6.2 Observations

Observe the specimens and record any obvious air bubbles trapped in the sealant during the preparation of test specimens.

H-7 CALCULATION

Calculate actual sealant minimum contact area, D , in square millimetres as follows:

$$D = A \times B$$

where,

A = sealant length, dimension A (see Fig. 15A, Fig. 15B, Fig. 15C and Fig. 16);

and

B = sealant bite, dimension B (see Fig. 15A, Fig. 15B, Fig. 15C and Fig. 16).

Calculate tensile stress as follows:

$$T = \frac{C}{D}$$

where,

T = tensile strength, MPa (psi); and

C = tensile load, N (lb).

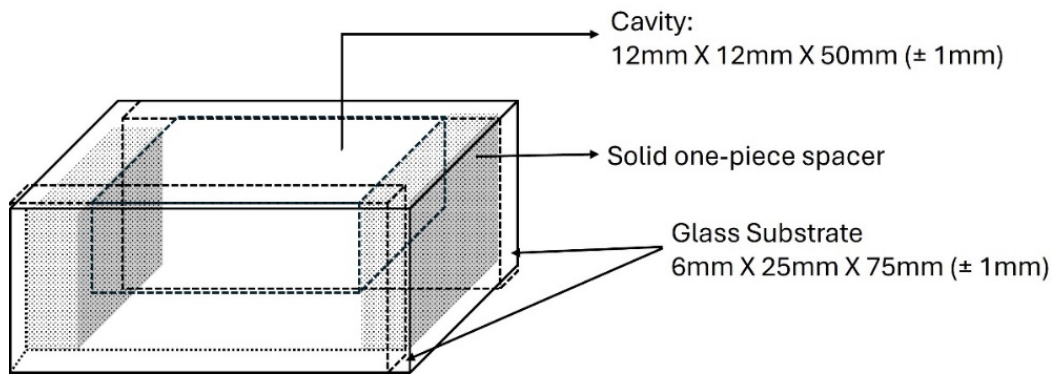

FIG. 15 (A)

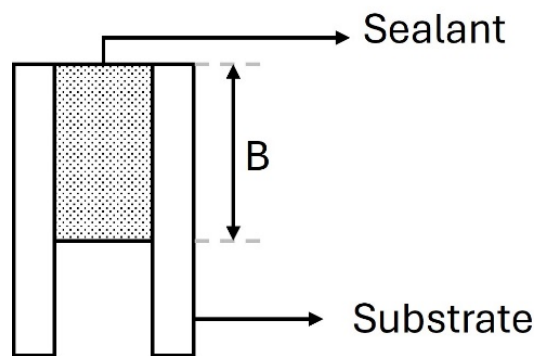

FIG. 15 (B)

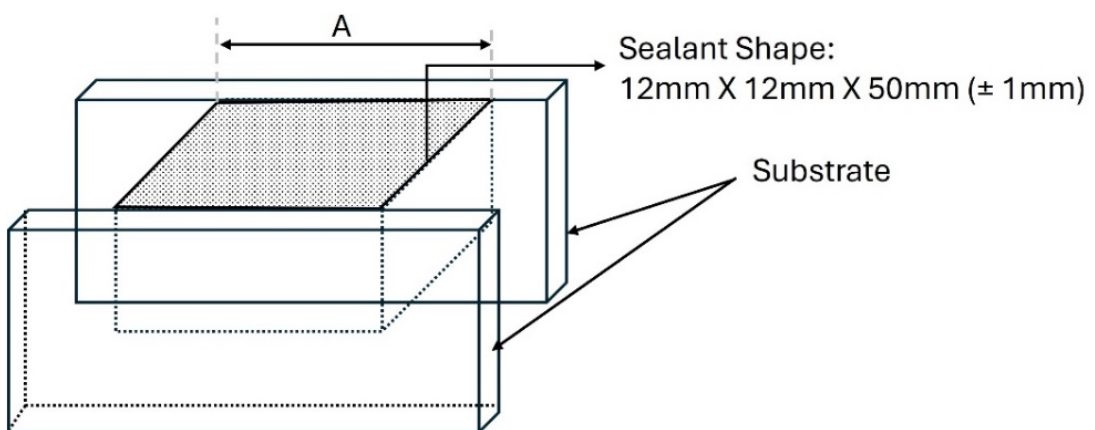
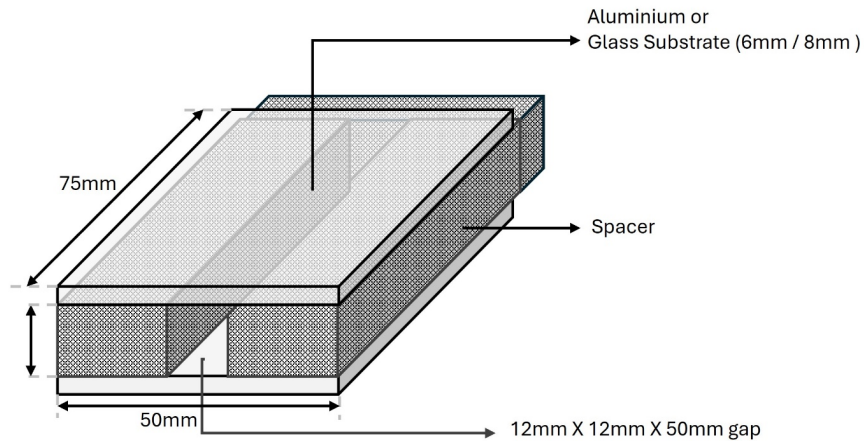

FIG. 15 (C)

FIG. 15 GLASS SUBSTRATE AND SPACER ASSEMBLED TO FORM A SEALANT CAVITY
(TAPE OR CLAMP SUBSTRATES TOGETHER PRIOR TO INJECTING THE SEALANT – TYPE
TA JOINT)



Tolerances shall be ± 1 mm

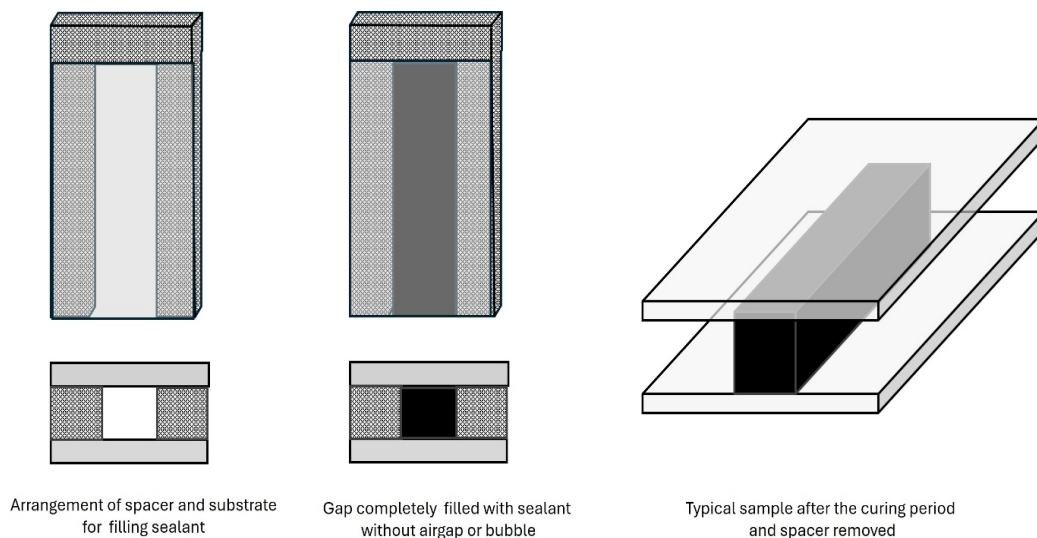

FIG. 16 GLASS SUBSTRATE AND SPACER ASSEMBLED TO FORM A SEALANT CAVITY (TAPE OR CLAMP SUBSTRATES TOGETHER PRIOR TO INJECTING THE SEALANT – TYPE H JOINT)

H-8 STANDARD TEST METHOD FOR DETERMINING TENSILE ADHESION PROPERTIES OF STRUCTURAL SEALANTS AFTER EXPOSURE TO (TEMPERATURE, WATER AND WEATHERING)

Follow the testing methodology as outlined above with rate of pull of 12 mm/min (± 1 mm/min) and determine the average ultimate tensile value for each group of five specimens prepared as described below.

Prepare, a total of 25 specimens for testing, except that the distance between substrates will be 9.5 mm. Cure all specimens for 21 days at standard conditions. Condition and test the specimens as described below.

H-8.1 Condition and testing

- a) Test five specimens at standard conditions after the initial curing period:
- b) Condition five specimens for 1 h at $88\text{ }^{\circ}\text{C} \pm 5\text{ }^{\circ}\text{C}$ in a forced air oven. Test the specimens at $88\text{ }^{\circ}\text{C} \pm 5\text{ }^{\circ}\text{C}$;
- c) Condition five specimens for 1 h at $-29\text{ }^{\circ}\text{C} \pm 2\text{ }^{\circ}\text{C}$. Test the specimens at $-29\text{ }^{\circ}\text{C} \pm 2\text{ }^{\circ}\text{C}$;
- d) Immerse five specimens in deionized or distilled water at standard temperature for seven days; and test the specimens at standard laboratory conditions within 10 min after their removal from the water.
- e) Expose five specimens with the bond surface facing the light source (Fluorescent UV and condensation apparatus). Operate the device expose the specimens for a minimum of 5000 h.

H-8.2 Procedure for UV Exposure

Use fluorescent UVA-340 lamps. The spectral power distribution of UVA-340 fluorescent lamps shall comply with the relevant standard.

In apparatus with irradiance control, irradiance shall be set at $0.89\text{ W}/(\text{m}^2\text{ nm})$ at 340 nm.

Seal any holes larger than 2 mm in specimens and any opening larger than 1 mm around irregularly shaped specimens to prevent loss of water vapor. Attach porous specimens to a solid backing, such as aluminum, that can act as a vapor barrier

For specimens that are less than 20 mm thick, including support dimensions, the exposure cycle shall be 8 h UV at an uninsulated black panel temperature set at $60\text{ }^{\circ}\text{C}$ followed by 4 h wetting by condensation at an uninsulated black panel temperature set at $50\text{ }^{\circ}\text{C}$. The maximum allowable operational temperature fluctuation is $\pm 2\text{ }^{\circ}\text{C}$

For specimens that are more than 20 mm thick, including support dimensions, the exposure cycle shall be 5 h UV only at an uninsulated black panel temperature set at $60\text{ }^{\circ}\text{C}$ followed by 1 h UV plus wetting by water spray on the front surface. The water temperature shall be less than $40\text{ }^{\circ}\text{C}$. The maximum allowable operational temperature fluctuation is $\pm 2\text{ }^{\circ}\text{C}$.

NOTE—Wetting by condensation is not applicable to specimens having a thickness greater than 20 mm because of inadequate heat transfer.

Initiate exposure at the beginning of the UV period.

Keep one test specimen as an unexposed file specimen and store at standard conditions and away from light.

Place at least three of the cured specimens and the control material, if used, in the artificial weathering apparatus with the sealant surface facing the radiation source.

H-8.3 Specimen Mounting and Arrangement

The test specimens shall be mounted so that the plane of the test surface is at a

distance from the lamps consistent with the practice for operation of that apparatus. Refer to the appropriate practice for information about proper specimen mounting.

Specimens should be confined to an exposure area in which the irradiance is at least 90 percentage of the irradiance at the centre of the exposure area. If the specimens do not completely fill the racks, fill the empty spaces with blank metal panels to maintain the test conditions within the chamber.

The apparatus shall be operated continuously. However, if the test needs to be interrupted to perform routine maintenance or inspection, it should be during a dry stage. Specimens should not be removed from the exposure apparatus for more than 24 h and then returned for additional exposure because this does not produce the same results on all materials as tests run without this type of interruption. When specimens have to be removed for more than 24 h, report the elapsed time.

H-8.4 Post Conditioning

After artificial weathering, condition the samples for at least 2 h at standard conditions before further testing.

ANNEX J*(Foreword)***ADDITIONAL INFORMATION****J-1 DEGLAZING**

Adhesion or lack of adhesion of a structural or non-structural sealant to the surface of another material or component is determined using **Annex H** for a structural sealant and either test method as per **Annex F**. The adhesion of silicone sealants to clean, uncoated glass has proven to be tenacious, while adhesion to other surfaces, such as coated glass and anodized or organically coated aluminium, has proven to be variable. In general, for most materials, sealant manufacturers have extensive previous adhesion testing experience and usually can indicate if their sealant will or will not adhere to a particular material's surface; therefore, prequalification testing usually is not necessary unless the manufacturer does not have relevant data. Prior to fabrication or installation, however, the sealant manufacturer on production run samples of those components should perform adhesion or lack of adhesion tests. Periodic verification testing conducted during fabrication or installation of the system should follow this. During fabrication, additional testing is required. For example, during shop fabrication structural sealants must be tested and documented to have adequate adhesion before curtain wall or window panelised units are shipped. Daily adhesion testing monitors sealant cure rate and adhesion development in the actual shop conditions. This is typically performed according to the sealant manufacturer's recommendations and then documented. The documents must be available for review by an owner's representative and the building code authority. These documents are also typically required to fulfil the project specification and manufacturer's warranty requirement. Another commonly used technique to confirm adhesion and joint filling is the physical removal of structural sealant glazed panels. Deglazing involves completely detaching the glazing or panel from the frame.

- a) The following inspection should document:
 - 1) dimension of structural sealant bite to both adhesion surfaces;
 - 2) dimension of structural sealant thickness;
 - 3) quality of the adhesion of the structural sealant to the glass or panel and the frame;
 - 4) if a two-component structural sealant is used any mixing deficiencies; and
 - 5) the joint type and any other relevant observations.

- b) Typically, the frequency of deglazing tests could be established as:
 - 1) 1 frame in the first 10 produced;
 - 2) 1 in the next 40;
 - 3) 1 in the next 50; and
 - 4) 1 every 100 thereafter.

Frequency will depend on the particular application requirements and the results of previous deglazing tests. Deglazing permits the production supervisors and workers to evaluate their work with regards to cleaning procedures and completely fill in the joint cavity. This test increases the fabricators awareness of the specific application and performance requirements for the particular structural sealant application. Performance of prequalification prefabrication, and fabrication testing will assist in identifying substrate or workmanship changes that could be detrimental to adhesion of a structural sealant.

J-2 SHELF LIFE

Sealants must be used within their stated shelf life. Generally, 12 months or as stated by the manufacturer, from date of manufacture subject to storage conditions. Sealant that is used beyond its stated shelf life may not cure properly to its full physical properties and must not be used.

J-3 MATERIAL STORAGE AND HANDLING

Sealants must be stored at the recommended temperature and environment.

Excessive temperatures or moisture may cause a sealant to be damaged. Sealant cure, adhesion and physical properties could be harmed if the sealant is not handled and stored properly. The sealant user must understand and follow the on the proper use of dispensing equipment for two-component silicone sealants.

J-4 CURING TIME AND TRANSPORTATION

It would take minimum of 24 h for the two-component silicone sealants to cure before transporting the panel from the production site. One component Sealants cures at the rate of about 1 mm/day. Care must be taken to ensure that the sealant has been completely cured and required Shore a value has been reached before despatching them to the site for glazing.

J-5 STRUCTURAL SILICONE SEALANT MODULUS OF ELASTICITY

J-5.1 General

Structural silicone sealants should be designed for both strength and flexibility for specific applications; this implies that the sealant's modulus of elasticity should fall between a maximum and minimum value for a specific application.

The modulus of elasticity of a material describes its elongation response to an applied stress, and therefore is a measure of its flexibility, stiffness, or hardness. The term "modulus" used in this appendix refers to a sealant's secant modulus of elasticity; (see terminology IS 10959). Note that the units of modulus and stress can be the same (such as pounds per square inch), but they represent different technical concepts. Because the modulus of a sealant is not constant, it is customary in the sealant industry to state both the modulus and the strain at which it was measured (for example, 99 kPa at 12.5 percent strain).

Structural silicone sealants are used to structurally attach glass and other materials to a framing system; to transfer loads applied to the glazing material to the framing system; and to accommodate anticipated movement between the glazed materials and the supporting framework. When selecting a structural sealant for a specific application, the design professional must select a sealant that has the necessary strength to resist applied loads, but also has enough flexibility to accommodate differential movement.

Currently, structural silicone sealants are manufactured to have performance properties which allow a particular material to be used in a wide variety of applications. If a particular structural silicone sealant is to be used in a specific application, it must have a modulus which is also acceptable for that application.

The modulus of a sealant may be a function (essentially linear) of temperature. It should be verified that the modulus will fall within the minimum and maximum criteria over the anticipated service temperature range.

To adequately evaluate a sealant for a specific application, a stress/strain plot should be developed for the specific project conditions utilizing Test method outline in Annex H. When developing the stress/strain plot, the test conditions (such as sealant joint configuration or environmental conditioning) should be modified to correlate with the conditions specified or predicted for the specific specification the application-specific stress/strain plots (developed using the average values for each set of test assemblies as described in test method in Annex H, in combination with the design criteria for the application, can be evaluated to determine if the proposed sealant is appropriate for the application.

J-5.2 Minimum Modulus

The minimum acceptable structural sealant modulus (softest, or highest acceptable flexibility is based on the premise that the sealant must be sufficiently stiff to retain the panel without excessive deflection. The limiting case is when the sealant depth is stressed by negative (outward acting) Winds or other lateral loads up to its design load; even at that stress it must not elongate beyond the practical limit of the design geometry (such as the setting blocks supporting the weight of the panel).

J-5.3 Maximum Modulus

The maximum acceptable modulus (hardest, or least acceptable flexibility is dictated by the requirement that the structural sealant joint must have sufficient flexibility to respond to the wind strain or differential thermal movement between the panel and the supporting framework, without being stressed in shear in excess of the design parameters.

J-6 DETERMINING CONFORMANCE TO RELATIVE SPECTRAL POWER DISTRIBUTION TABLES

Conformance to the relative spectral power distribution tables is a design parameter

for fluorescent UV device with the different lamps that can be used. Manufacturers of equipment claiming conformance to this practice shall determine conformance to the spectral power distribution tables for all fluorescent lamps provided, and provide information on maintenance procedures to minimize any spectral changes that may occur during normal use.

The relative spectral power distribution data for this practice were developed using the rectangular integration technique. Below mentioned equation is used to determine the relative spectral irradiance using rectangular integration. Other integration techniques can be used to evaluate spectral power distribution data, but may give different results. When comparing relative spectral power distribution data to the spectral power distribution requirements of this practice, use the rectangular integration technique.

To determine whether a specific fluorescent UV lamp for a fluorescent UV device meets the requirements of Table 1 measure the spectral power distribution from the lower wavelength indicated in Below mentioned equation to an upper wavelength of 400 nm. Typically, this is done at 2 nm increments. The total irradiance in each wavelength bandpass is then summed and divided by the specified total UV irradiance according to below mentioned equation Use of this equation requires that each spectral interval must be the same (for example, 2 nm) throughout the spectral region used.

$$I_R = \frac{\sum_{\lambda_i=A}^{\lambda_i=B} E_{\lambda_i}}{\sum_{\lambda_i=C} E_{\lambda_i}} \times 100$$

where:

- I_R = relative irradiance in percent,
- E = irradiance at wavelength λ_i (irradiance steps must be equal for all bandpasses),
- A = lower wavelength of wavelength bandpass,
- B = upper wavelength of wavelength bandpass,
- C = lower wavelength of total UV bandpass used for calculating relative spectral irradiance (290 nm for UVA 340 lamps, 300 nm for UVA 351 lamps, or 250 nm for UVB 313 lamps), and
- λ_i = wavelength at which irradiance was measured