

**भारतीय मानक ब्यूरो**

(उपभोक्ता मामले, खाद्य एवं सार्वजनिक वितरण मंत्रालय, भारत सरकार)

BUREAU OF INDIAN STANDARDS

(Ministry of Consumer Affairs, Food & Public Distribution, Govt. of India)

मानक भवन, 9, बहादुर शाह ज़फर मार्ग, नई दिल्ली - 110002
Manak Bhawan, 9, Bahadur Shah Zafar Marg, New Delhi - 110002
Phones: 23230131 / 2323375 / 23239402
Website: www.bis.gov.in, www.manakonline.in

व्यापक परिचालन मसौदा

हमारा संदर्भ : सीईडी 02:2/टी-107

30 मई 2024

तकनीकी समिति : सीमेंट और कंक्रीट अनुभागीय समिति , सीईडी 02

प्राप्तकर्ता :

- सिविल अभियांत्रिकी विभाग परिषद, सीईडीसी के सभी सदस्य
- सीमेंट और कंक्रीट अनुभागीय समिति , सीईडी 02
- सीईडी 02 की उपसमितियों और अन्य कार्यदल के सभी सदस्य
- रुचि रखने वाले अन्य निकाय।

महोदय/महोदया,

निम्नलिखित मानक का मसौदा संलग्न है:

प्रलेख संख्या	शीर्षक
सीईडी 02(25735)WC	पोस्ट स्थापित मैकेनिकल एंकरिंग सिस्टम का परीक्षण और मूल्यांकन (आई सी एस संख्या : 91.100.30)

कृपया इस मसौदे का अवलोकन करें और अपनी सममतियाँ यह बताते हुए भेजे कि यह मसौदा प्रकाशित हो तो इन पर अमल करने में आपको व्यवसाय अथवा कारोबार में क्या कठिनाइयां आ सकती हैं।

सममतियाँ भेजने की अंतिम तिथि: 30 जुलाई 2024

सम्मति यदि कोई हो तो कृपया अधोहस्ताक्षरी को ई-मेल द्वारा ced2@bis.gov.in पर या उपरलिखित पते पर, संलग्न फॉर्मेट में भेजें। सममतियाँ बीआईएस ई-गवर्नेंस पोर्टल, www.manakonline.in के माध्यम से ऑनलाइन भी भेजी जा सकती हैं।

यदि कोई सम्मति प्राप्त नहीं होती है अथवा सम्मति में केवल भाषा संबंधी त्रुटि हुई तो उपरोक्त प्रालेख को यथावत अंतिम रूप दे दिया जाएगा। यदि सम्मति तकनीकी प्रकृति की हुई तो विषय समिति के अध्यक्ष के परामर्श से अथवा उनकी इच्छा पर आगे की कार्यवाही के लिए विषय समिति को भेजे जाने के बाद प्रालेख को अंतिम रूप दे दिया जाएगा।

यह प्रालेख भारतीय मानक ब्यूरो की वेबसाइट www.bis.gov.in पर भी उपलब्ध हैं।
धन्यवाद।

भवदीय

ह/-

द्वैपायन भद्र

वैज्ञानिक ई एवं प्रमुख

सिविल अभियांत्रिकी विभाग

संलग्न: उपरलिखित

**भारतीय मानक ब्यूरो**

(उपभोक्ता मामले, खाद्य एवं सार्वजनिक वितरण मंत्रालय, भारत सरकार)

BUREAU OF INDIAN STANDARDS

(Ministry of Consumer Affairs, Food & Public Distribution, Govt. of India)

मानक भवन, 9, बहादुर शाह ज़फ़र मार्ग, नई दिल्ली - 110002

Manak Bhawan, 9, Bahadur Shah Zafar Marg, New Delhi - 110002

Phones: 23230131 / 2323375 / 23239402

Website: www.bis.gov.in, www.manakonline.in**WIDE CIRCULATION DRAFT****Our Reference: CED 02:2/T-107****30 May 2024****TECHNICAL COMMITTEE: CEMENT AND CONCRETE SECTIONAL COMMITTEE, CED 02****ADDRESSED TO:**

1. All Members of Civil Engineering Division Council, CEDC
2. All Members of Cement and Concrete Sectional Committee, CED 02 and its Subcommittees
3. All Members of Subcommittees, Panels and Working Groups under CED 02
4. All others interested.

Dear Sir/Madam,

Please find enclosed the following draft:

Doc No.	Title
CED 02(25735)WC	Testing and Assessment of Post-Installed Mechanical Anchoring Systems ICS 91.100.30

Kindly examine the attached draft and forward your views stating any difficulties which you are likely to experience in your business or profession, if this is finally adopted as National Standard.

Last Date for comments: 30 July 2024

Comments if any, may please be made in the enclosed format and emailed at ced2@bis.gov.in or sent at the above address. Additionally, comments may be sent online through the BIS e-governance portal, www.manakonline.in.

In case no comments are received or comments received are of editorial nature, kindly permit us to presume your approval for the above document as finalized. However, in case comments, technical in nature are received, then it may be finalized either in consultation with the Chairman, Sectional Committee or referred to the Sectional Committee for further necessary action if so desired by the Chairman, Sectional Committee.

The document is also hosted on BIS website www.bis.gov.in.

Thanking you,

Yours faithfully,

Sd/-

Dwaipayan Bhadra

Scientist 'E' & Head

Civil Engineering Department

Encl: As above

BUREAU OF INDIAN STANDARDS
DRAFT STANDARD FOR COMMENTS ONLY

(Not to be reproduced without the permission of BIS or used as an Indian Standard)

Draft Indian Standard

Testing and Assessment of Post-Installed Mechanical Anchoring Systems
ICS 91.100.30

Cement and Concrete
Sectional Committee, CED 02

Last Date for Comments:
30 July 2024

FOREWORD

(Formal clauses of the standard to be added later)

Various fastening techniques are used extensively for the transfer of loads into concrete structural elements. One such technique that is, post-installed anchors, installed in hardened structural concrete elements, has become quite common in the last two decades in India. Despite the extensive use of post-installed anchors in construction, the level of adequate knowledge regarding their behaviour is only increasing now.

Failure of connections poses risk to human life and considerable economic consequences. Hence, they should be designed, assessed, and evaluated in accordance with the well-established engineering principles. Suitable guidance is therefore required for proper design of such system to ensure safety. CED 02(25733) has been formulated to fulfil the above requirement.

Testing plays an important role in controlling the quality of anchors being used for such post installed connections. This helps achieve a higher efficiency of the anchors used and greater assurance of the performance of the same in adverse environmental and loading conditions. The test methods used should be simple, direct and convenient to apply. This standard was formulated with this objective in view. This standard would provide thus the requisite guidance regarding the test regime to be adopted for proper assessment, assessment procedure, selection and thereby design of post installed mechanical anchors for use in concrete.

In the formulation of this standard, assistance has been derived from the following publication:

1. EOTA EAD 330232-01-0601 European Assessment Document – Mechanical Fasteners for Use in Concrete

An informative annex (see Annex F) detailing out the procedure for issuance of assessment report has been introduced.

BUREAU OF INDIAN STANDARDS
DRAFT STANDARD FOR COMMENTS ONLY

(Not to be reproduced without the permission of BIS or used as an Indian Standard)

Draft Indian Standard

Testing and Assessment of Post-Installed Mechanical Anchoring Systems
ICS 91.100.30

1 SCOPE

1.1 This standard covers the tests and assessment methods required for evaluating performance of post-installed mechanical anchors, namely, expansion anchors, undercut anchors and concrete screws, in concrete when subjected to static or quasi-static, and seismic loading conditions. The evaluation is done to determine suitability of use and derive characteristic values for design purposes.

1.2 This standard outlines the tests required to evaluate the performance of post installed mechanical anchors, namely, expansion anchors, undercut anchors and concrete screws, in concrete prior to issuance of the assessment report.

NOTE – This does not apply to quality control measures at jobsite.

1.3 The testing and assessment of post installed mechanical anchors shall be done by a Third party Testing Laboratory and Evaluation Agency, and Assessment Report (AR) shall be issued by the Approval Body in accordance with this standard. The AR is not project specific.

1.4 The characteristic values reported in AR shall be used for design of post-installed mechanical anchors in concrete according to CED 02(25733).

NOTE – It is the sole responsibility of the manufacturer to coordinate with the Third Party Testing Laboratory, the Evaluation Agency and the Approval Body to obtain the AR.

Commentary – European Technical Assessment (ETA) prepared based on European Assessment Document (EAD) is an example of Assessment Report (AR) which is globally adopted.

2 REFERENCES

The standards (and documents) given in Annex A contain provisions which, through reference in this text, constitute provisions of this standard. At the time of publication, the editions indicated were valid. All standards are subject to revision, and parties to agreements based on these standards are encouraged to investigate the possibility of applying the most recent editions of the standards given in Annex A.

3 TERMINOLOGY

The terminologies in this document shall be read in conjunction with the definition of terms given CED 02(25733). In addition, the following definitions shall apply:

3.1 Anchor Installation – The process of installing anchor defined by the manufacturer for the subject anchor, unless otherwise specified.

3.2 Approval Body – An organization or group of experts that issue the Assessment Report (AR) for post-installed anchoring system tested and assessed according to applicable testing and assessment standards for the designated use.

3.3 Bond breaker – A device (such as pipes) used to create debonding of rebar with concrete of the test member in specific lengths along the length of the rebar to allow free elongation of the rebar (see Fig. 8A). It is to be ensured during casting that the concrete does not enter the pipe.

3.4 Characteristic Strength – The value of resistance to be published in the AR document of a post installed anchor for the respective failure mode to be considered in design.

3.5 Crack inducers – A device (such as, metal sheets, PVC sheets, etc.) to induce discontinuity in the concrete test member to steer the direction of formation of crack plane close to the anchors (see Fig. 7).

3.6 Evaluation Agency – An independent body that evaluates the performance of post-installed anchoring products based on test results carried out by a third party testing laboratory, in accordance with applicable testing and assessment standards for the designated use. This independent body should have proven experience of thorough testing and/ or evaluation of the product(s), compliant with the applicable standards.

3.7 Installation Expansion – The expansion achieved by applying a specified expansion, reduced in relation to reference expansion. The installation expansion is used in the installation safety tests.

3.8 Setting of an Anchor – The process of activating the load transfer mechanism of an anchor in a drilled hole.

3.9 Test Member – Concrete member in which the anchor is tested.

3.10 Test Series – It comprises of a group of identical anchors tested under identical conditions of anchor diameter, length, embedment, spacing, edge distance, drill hole diameter and depth, concrete density/weight, test member thickness and concrete compressive strength.

3.11 Third Party Testing Laboratories (Accreditation and Calibration) – Testing laboratories that are accredited by an accreditation body and have experience in anchor testing.

3.12 Unidirectional Crack – Crack running in one direction with an almost constant width over the member depth.

3.13 5th Percentile value – The value with 95 percent probability of being exceeded with a confidence level of 90 percent.

4 SYMBOLS AND NOTATIONS

For the purpose of this standard, the following letter symbols shall have the meaning indicated against each; where other symbols are used, they are explained at the appropriate place.

4.1 Suffixes

a — Anchor

bolt	—	Bolt
c	—	Concrete
cr	—	Critical
cr'	—	Cracked
uncr'	—	Uncracked
d	—	Design Value
fix	—	base plate/ fixture
ini	—	Initial
inst	—	Installation
m	—	mean
max	—	Maximum
min	—	Minimum
p	—	Pull-out / Pull-through
r	—	reference test
R	—	Strength/ Resistance
R _k	—	Characteristic or 5%-percent fractile value
s	—	Steel
sle	—	Sleeve
sp	—	Splitting
sus	—	Sustained
TS	—	Test series
TM	—	Test member
u	—	Ultimate
y	—	Yield
95%	—	95%-percentile

4.2 Symbols

A_s	—	Stressed cross-section area of anchor
A_{TM}	—	Cross-section area of test member
b	—	Width of test member
c'	—	Distance of anchor from its center to edge of concrete member
$c'_{cr,N}$	—	Critical edge distance of an anchor for concrete cone failure
$c'_{cr,Np}$	—	Critical edge distance of an anchor for bond / pull-out failure.
$c'_{cr,sp}$	—	Critical edge distance of an anchor for splitting failure
c'_{min}	—	Minimum edge distance of an anchor
CF	—	Centric compression force to be applied on test member in crack cycling test
D	—	Concrete member or base material thickness
d_a	—	Anchor diameter
d_{cut}	—	Cutting diameter of drill bit
$d_{cut,m}$	—	Cutting diameter of drill bit in medium tolerance range
$d_{cut,max}$	—	Cutting diameter of drill bit in maximum tolerance range
$d_{cut,min}$	—	Cutting diameter of drill bit in minimum tolerance range
d_{fix}	—	Diameter of clearance hole in base plate/ fixture
D_{min}	—	Minimum thickness of concrete member in which the anchor can be installed without damaging the concrete member
d_0	—	Drill hole diameter
d_1	—	Diameter of drill bit for undercutting
f_{ck}	—	Characteristic cube compression strength of concrete (measured on cube with side length of 150 mm)
f_{cm}	—	Mean compressive strength of concrete
f_u	—	Ultimate tensile stress for steel

f_y	—	Yield strength of steel
h_{ef}	—	Effective anchorage/ embedment depth
l_b	—	Bond length
l_{db}	—	Debonding length
N	—	Normal force; positive in tension, negative in compression
N_{sus}	—	Sustained tension load applied on anchor during crack cycling test for anchor evaluation for static load conditions
$N_{Rk,cr'}$	—	Characteristic tension strength in cracked concrete
$N_{Rk,uncr'}$	—	Characteristic tension strength in uncracked concrete
N_{TM}	—	Load applied to test member during crack cycling test (anchor evaluation for static load conditions) to obtain specified crack width movement
s'	—	Spacing of anchor in an anchor group
$s'_{cr,N}$	—	Critical spacing between anchors for concrete cone failure
$s'_{cr,Np}$	—	Critical spacing between anchors for bond pullout failure
$s'_{cr,sp}$	—	Critical spacing between anchors for splitting failure
s'_{min}	—	Minimum spacing between anchors
T_{inst}	—	Installation torque
t_{fix}	—	Thickness of base plate/ fixture
V	—	Shear force
v	—	Coefficient of variation (COV); It is the ratio of standard deviation to mean value multiplied by 100%. It is denoted as percentage
W	—	Crack width
Δw	—	Difference in crack width during loading of the anchor and crack width after installing the anchor
δ	—	Displacement
γ	—	Partial safety factor
γ_{inst}	—	Partial safety factor for installation
α	—	Reduction factor
β_{vF}	—	Reduction factor for coefficient of variation

5 APPARATUS

5.1 General Practice

The testing equipment shall be rigid enough to prevent yielding of its components under the anticipated ultimate load to ensure that the applied tension loads remain parallel to the axes of the anchors and that the applied shear loads remain parallel to the surface of the test member during testing. The load application device shall be designed to avoid sudden increase in test load especially at the beginning of the test. In addition, other equipment like torque wrench, borescope etc. may be required.

5.2 Load and Displacement Measuring Device

Calibrated load and displacement measuring devices, having traceable calibration record and conforming to national/ international standards, shall only be used. The measuring error of the load measuring equipment shall not exceed 2 percent. Displacement measuring devices with an accuracy of ± 0.02 mm or 2 percent for displacements larger than 1 mm shall be used. The measuring error for crack width shall not be greater than 0.02 mm.

5.3 Fixture

The load shall be applied to the anchor by a fixture that is representative of the conditions found in practice. Steel fixtures shall be used for applying tension or shear loads during the tests. The diameter of the clearance hole to be provided in the fixture (for example, see Fig. 1) shall be in accordance with the values given in Table 1.

Table 1 Size of Clearance Holes in Fixture
(Clause 5.3)

Anchor diameter d^1 (mm)	Diameter d_{fix} of clearance hole in the base plate (mm)
$d < 10 \text{ mm}$	$d_{fix} = d + 1$
$10 < d < 24 \text{ mm}$	$d_{fix} = d + 2$
$d > 24 \text{ mm}$	$d_{fix} = d + 3$

NOTE

$$^1 d = \begin{cases} d_a, & \text{if bolt bears against the fixture} \\ d_{nom}, & \text{if sleeve bears against the fixture} \end{cases}$$

NOTE – The above dimensions as per Table 1 shall not be applicable for concrete screws. For concrete screws, reference shall be made to the AR of the anchor.

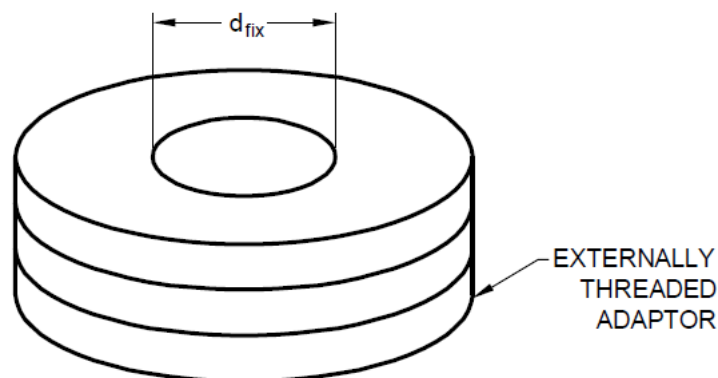

FIG. 1 TYPICAL FIXTURE FOR UNCONFINED TENSION TESTS

5.4 Unconfined Tension Test Set Up

The device shall be such that the load can be applied concentrically to the anchor. The load shall be applied to the anchor by a fixture which simulate practical loading scenario. A typical unconfined tension test setup is illustrated in Fig. 2. The test setup shall not restrict the formation of rupture concrete cone (of vertex angle 120°). To fulfill this requirement, the clear distance between the support reaction and a single anchor or the outer anchor of the anchor group shall be at least $2h_{ef}$ for tension test. Special fixtures as shown in Fig. 1 should be used for this test. The inner diameter of the fixture shall correspond to the sizes given in Table 1. An internally threaded bell-shaped fixture connected to pullout rod may be threaded on to this externally threaded adapter.

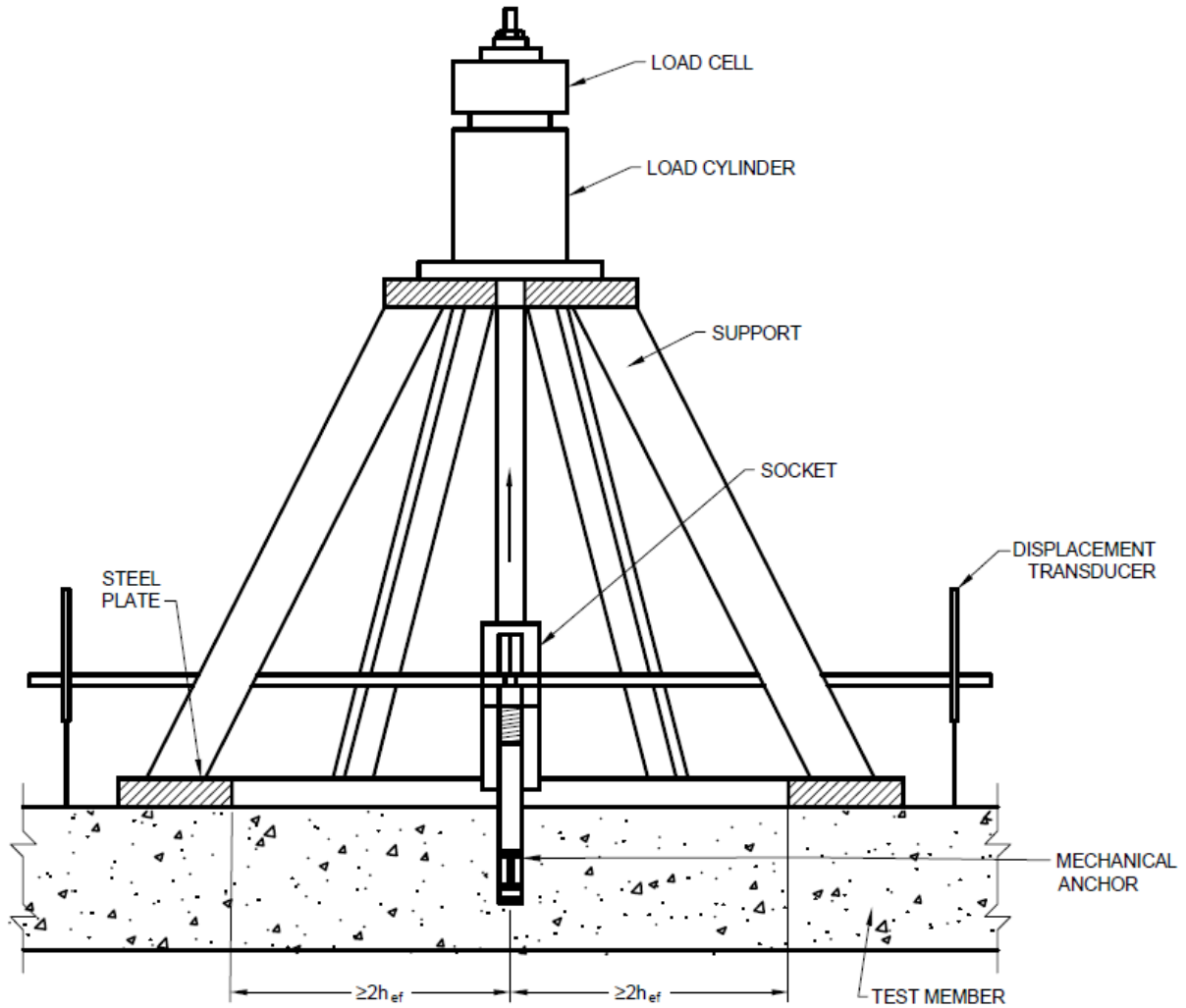

FIG. 2 TYPICAL UNCONFINED TENSION TEST SETUP

5.5 Shear Test Set Up

The device shall be such that the load can be applied parallel to the concrete surface. A plate with interchangeable sleeves may be used for testing anchors of different sizes (see Fig. 3). The sleeves shall be made of hardened steel and have round edges with 0.4 mm radius where in contact with the anchor. The height of the sleeves shall be approximately equal to the outside diameter of the anchor. The inner diameter of the sleeve shall correspond to the sizes given in Table 1. To reduce friction, smooth sheets like Poly-tetra-fluoro-ethylene (PTFE) with a maximum thickness of 2 mm shall be placed between the load plate with sleeve and the test member. A typical horizontal shear test setup is illustrated in Fig. 4. The test member may be stressed by a torsion moment as there is a lever arm between the applied load and the support reaction. This shall be taken up by placing additional reaction forces sufficiently far away from the anchor. The test setup shall not restrict the formation of rupture concrete cone. To fulfill this requirement, the clear distance between the support reaction and a single anchor or the outer anchor of anchor group shall be at least $2c'_1$ (edge distance in direction of the load) for shear test at the edge. It shall be permissible to reduce this clear distance in shear tests without edge influence, where steel failure is expected.

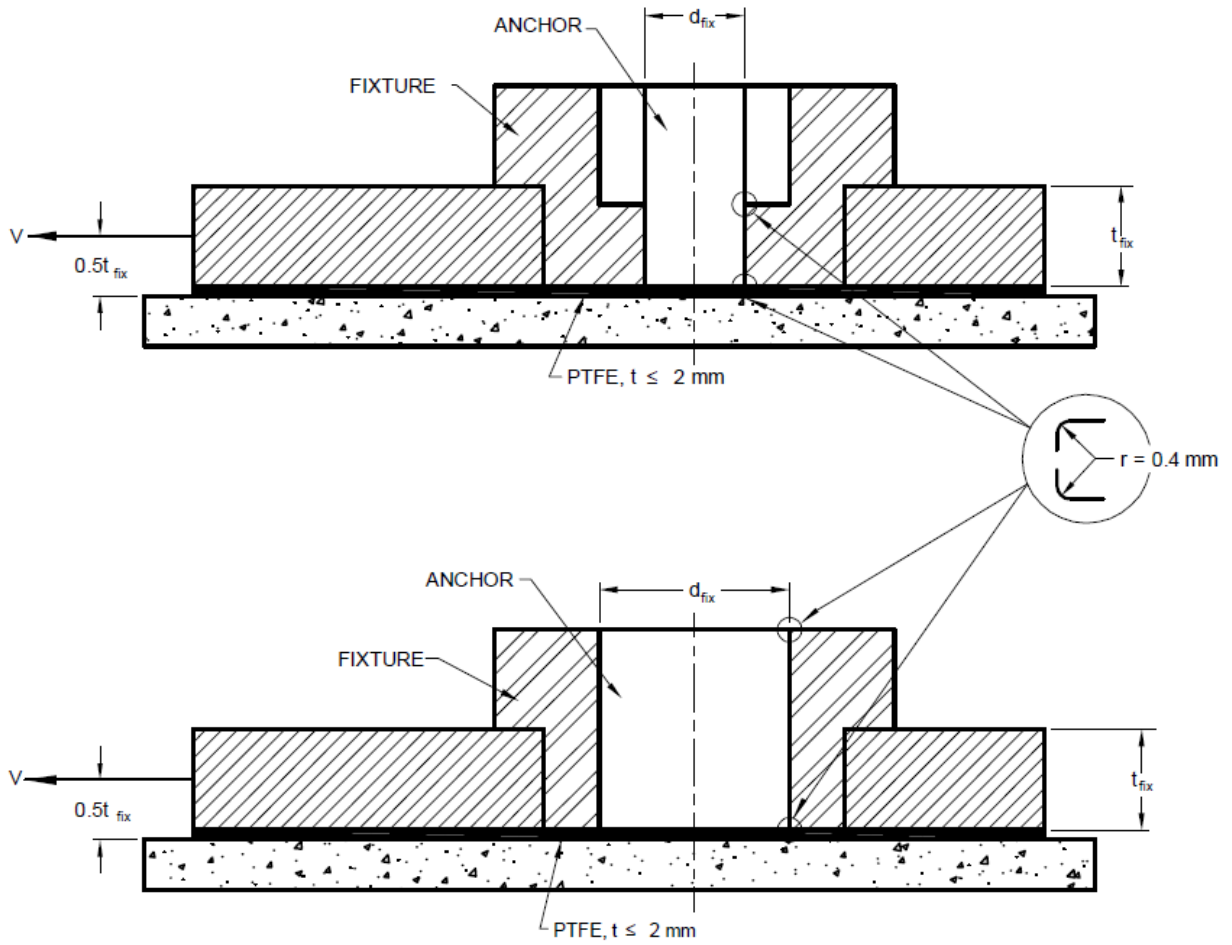

FIG. 3 TYPICAL SHEAR TEST SETUP FIXTURE

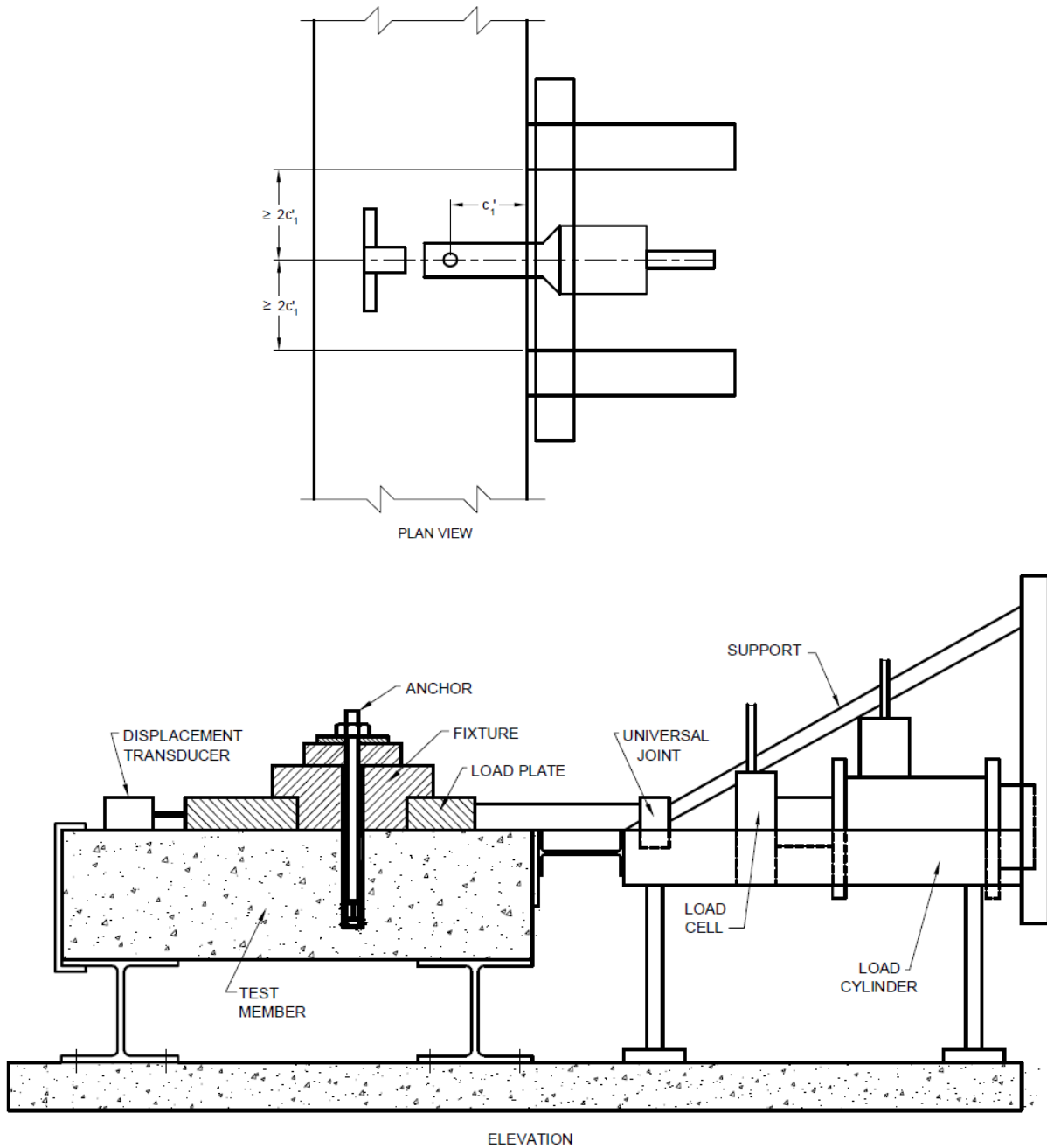

FIG. 4 TYPICAL SHEAR TEST SETUP

5.6 Alternating Shear Test Set Up

In addition to the requirements of 5.5, the device shall be such that the uplift of the shear fixture is restrained i.e., significant friction forces are not induced by using roller bearing (see Fig. 5). Any exception to annular gap requirement of Table 1 for seismic condition shall be explicitly stated in the AR after testing it accordingly.

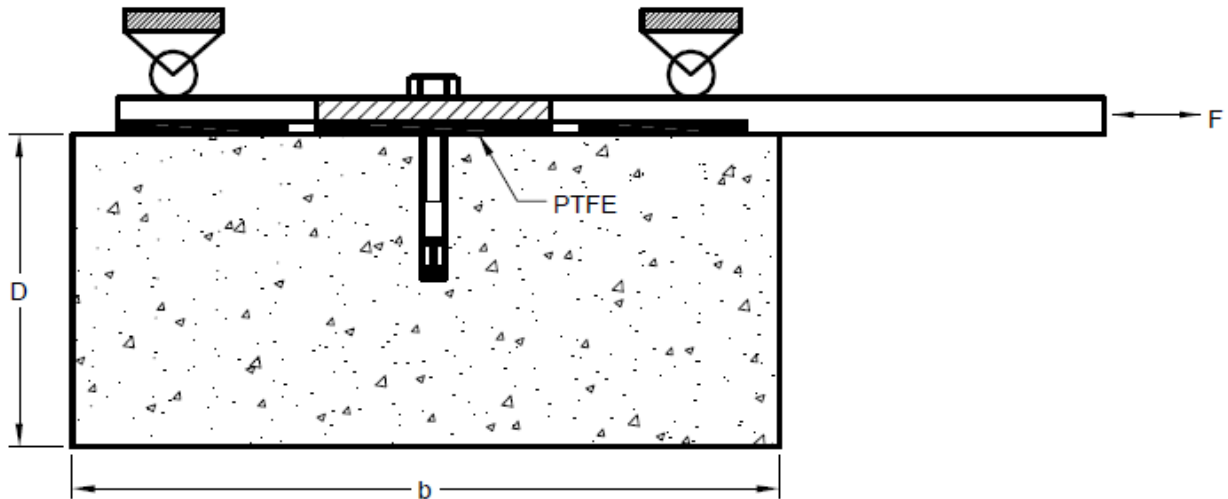

FIG. 5 TYPICAL ALTERNATING SHEAR TEST SETUP

5.7 Torque Test Set Up

A calibrated torque wrench and a calibrated load cell shall be used to apply the torque and measure the tensile force generated, respectively. The load cell shall be used as a fixture as shown in Fig. 6. The inner diameter of this fixture (d_{fix}) shall correspond to the sizes given in Table 1. The measuring error of the calibrated load cell used for this test should not exceed 3 percent throughout the whole measuring range. Any rotation of the spherical part of the fixture should be prevented.

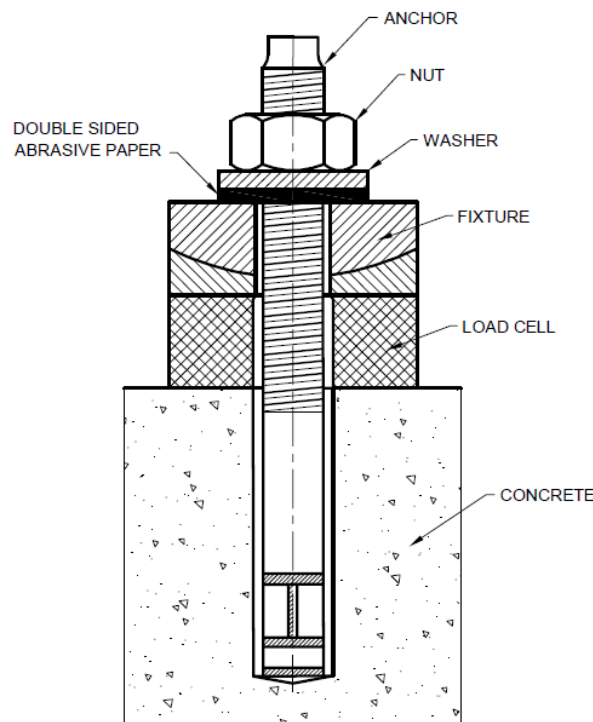

FIG. 6 TYPICAL TORQUE TEST SETUP

6 TEST SPECIMEN

6.1 General

6.1.1 The concrete strength of test member in which the anchor is to be embedded and tested shall be as specified in the test series.

6.1.2 The average cube compressive strength of 'standard concrete' in the test series shall be in the range of 25 MPa to 35 MPa.

6.1.3 The average cube compressive strength of 'high strength concrete' shall be in the range of 60 MPa to 70 MPa.

6.1.4 Test member shall be made of normal weight concrete as per IS 456. The concrete mix, unless otherwise specified, shall not have any additives like fly ash, silica fume, fibers etc. that may alter the concrete properties. The concrete specification and standards shall be clearly documented in the test report.

6.1.5 The test members shall be cast horizontally with their concrete sampling done as control specimens as test cubes/ cylinders. If cylindrical control specimens are casted, their strength shall be converted into cube strength as per best practice.

6.1.6 Test members and control specimens shall be cured and stored indoors for seven days. After seven days, the test members and control specimens may be stored outside, provided they are protected from weather conditions such as frost, rain etc. which are likely to cause deterioration of the concrete compression and tension strength. In absence of control specimens, concrete cores from test member may be tested to establish strength at time of testing anchor specimen. The concrete test member shall be at least 28 days old at the time of anchor testing.

6.1.7 To determine the concrete strength of test member at the time of testing anchor specimen, the concrete control specimens shall be tested on the same day as the anchor test to which they relate. If a test series takes multiple days for completion, then the concrete control specimens should be tested at a time which gives the best representation of the concrete strength at the time of the anchor tests, for example, at the beginning and at the end of the tests. The concrete strength at the time of testing can be determined by interpolation of the results.

6.2 Uncracked Concrete Test Member for Static Tests

6.2.1 Test members for uncracked concrete tests shall be unreinforced. Minimal reinforcement may be provided for handling and transportation as per best practice. When test members contain reinforcement to allow handling or for the distribution of loads transmitted by the test equipment, the reinforcement shall be positioned such that the loading capacity of the anchors is not influenced. This requirement shall be considered fulfilled when the reinforcement is located outside the concrete cone area of anchor having a vertex angle of 120°.

6.2.2 The test member thickness shall be greater than minimum concrete member thickness recommended by the manufacturer ($D \geq D_{min}$).

6.3 Cracked Concrete Test Member for Static Tests

6.3.1 Test members for cracked concrete tests shall be reinforced with reinforcement ratio of the cross section about 1 percent and the spacing of the bars not more than 250 mm. A typical cracked concrete test member is shown in Fig. 7.

NOTE - Cracked concrete member other than recommended in this section shall be permitted as long as it can be demonstrated that the crack requirement of this standard is fulfilled.

6.3.2 The thickness of the test member shall not be less D_{min} as recommended by the manufacturer.

6.3.3 Crack inducers may be built into the test member to control location and propagation of cracks. The crack inducers shall be located such that they are not close to the anchorage zone and do not influence loading capacity of anchor.

6.3.4 The cracks shall be unidirectional, and the crack width shall be approximately constant throughout the member thickness.

6.3.5 Procedure for Crack Opening to Specified Crack Width

After anchor is installed in the crack, the crack shall be widened to the specified crack width, as stated in each test series, prior to loading. This process of installation of anchor in crack, followed by crack widening is explained as follows:

- The crack (also referred to as “hairline” crack) shall be first initiated/created in the concrete test member using crack inducers as explained herein before.
- The anchor shall then be installed at the location of the hairline crack. Depending on the type and size of the anchor to be tested, the crack width may slightly change during the installation procedure. This value should be noted as the crack width after the installation of the anchor.
- After installation, the crack width measuring device should be set to zero. The crack width shall be then opened to the specified value Δw . After crack is widened to the specified value, the anchor shall be loaded.

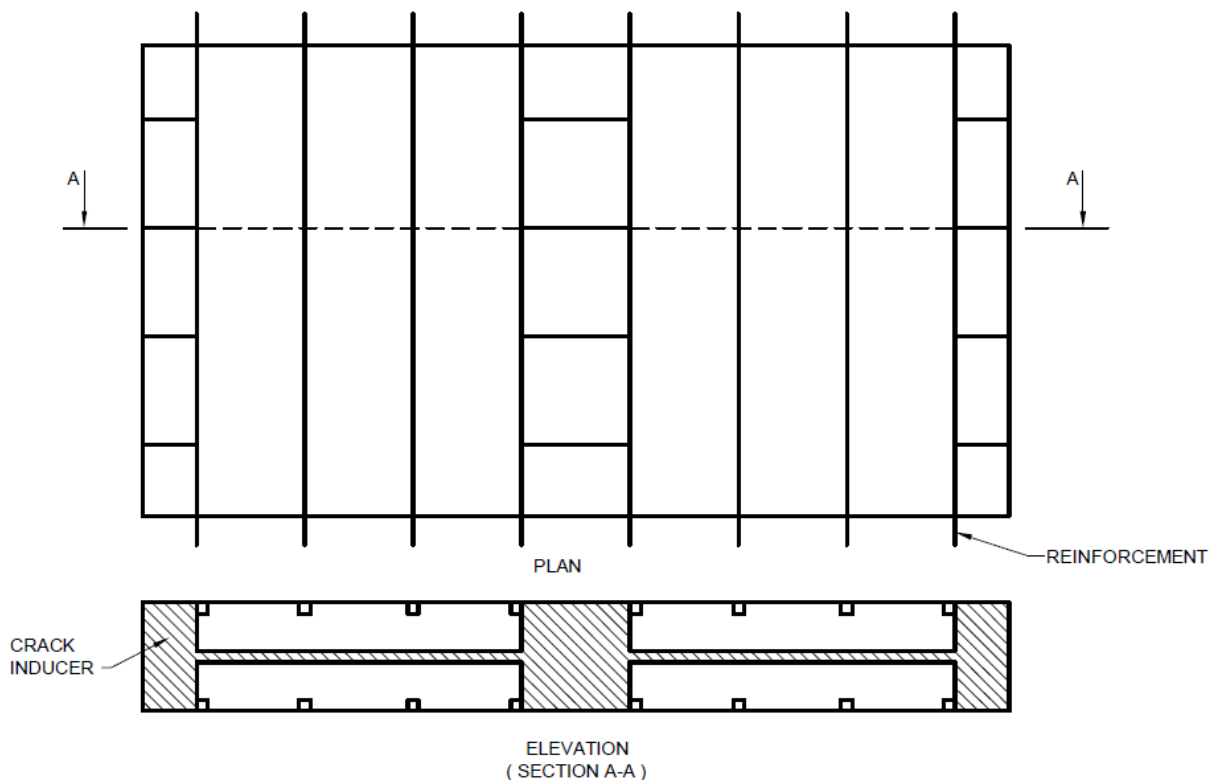

FIG. 7 TYPICAL CRACKED CONCRETE TEST MEMBER

6.4 Cracked Concrete Test Member for Crack Cycling Test and Seismic Tests

6.4.1 Test members for cracked concrete condition for seismic tests shall be reinforced. The reinforcement ratio of the cross section should be about 1 percent and the spacing of the bars should be less than or equal to 400 mm. The reinforcement used shall be of equal diameter and placed symmetrically. The reinforcement shall remain in elastic range during each test. The bond length (ℓ_b) between the potential crack planes and at both end of test member shall be such that the introduction of tension force into concrete is possible (see Fig. 8).

NOTE – Cracked concrete member other than recommended in this section shall be permitted as long as it can be demonstrated that the crack requirement of this standard are fulfilled.

6.4.2 The thickness of the test member shall not be less than D_{min} as recommended by the manufacturer. The width of test member shall be large enough to avoid edge influence on anchor behavior. The width requirement shall be considered fulfilled if the concrete cone breakout does not intersect with edge or the edge distance of anchor in all directions is greater than $2h_{ef}$.

6.4.3 To facilitate opening of crack width as required for the test series, a bond breaker (e.g., plastic pipe) may be applied at both sides of the crack.

NOTE - A plastic pipe with an inner diameter of about 1.2 times the reinforcement diameter may be used. The debonding length (ℓ_{db}) should be about 5 times the reinforcement diameter.

6.4.4 The cracks shall be unidirectional, and the crack width shall be approximately constant throughout the member thickness.

6.4.5 At least three test members shall be tested during designing the cracked concrete member to establish constant crack width for anchor with highest ultimate load to be tested in this member in tension.

6.4.6 The crack width at the level of embedment and at the top surface of test member where anchor is installed shall be measured as illustrated in Fig. 9. The constant crack width requirement shall be deemed to be established if the ratio of crack width measured at location 3 & 4 to location 1 & 2 is less than 1.05 and the crack width at the level of embedment (location 5 & 6) as illustrated in Fig. 9 is greater than or equal to the specified crack width.

6.4.7 The anchor test location shall be selected such that the reinforcement does not influence the anchor performance (i.e., reinforcement should not be in expected concrete cone area). This requirement shall be considered fulfilled if the distance between the anchor and the nearest reinforcement (a_s) is at least greater of 75 mm and $0.6h_{ef}$ (see Fig. 8A). If this distance requirement cannot be fulfilled for anchors with large embedment depth with reinforcement spacing of less than 400 mm, then it shall be established during test that the reinforcement does not intersect with concrete cone breakout area.

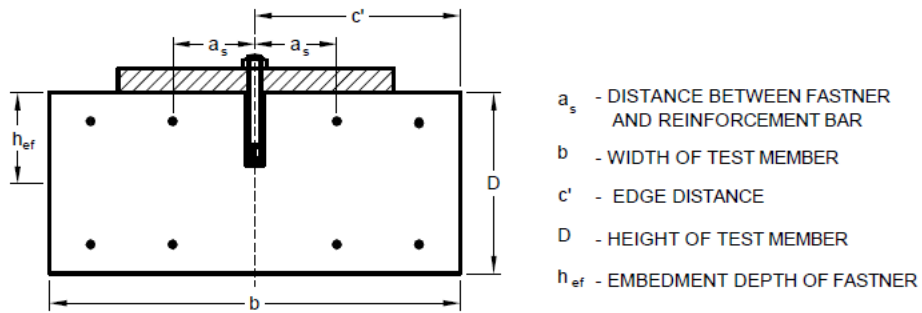
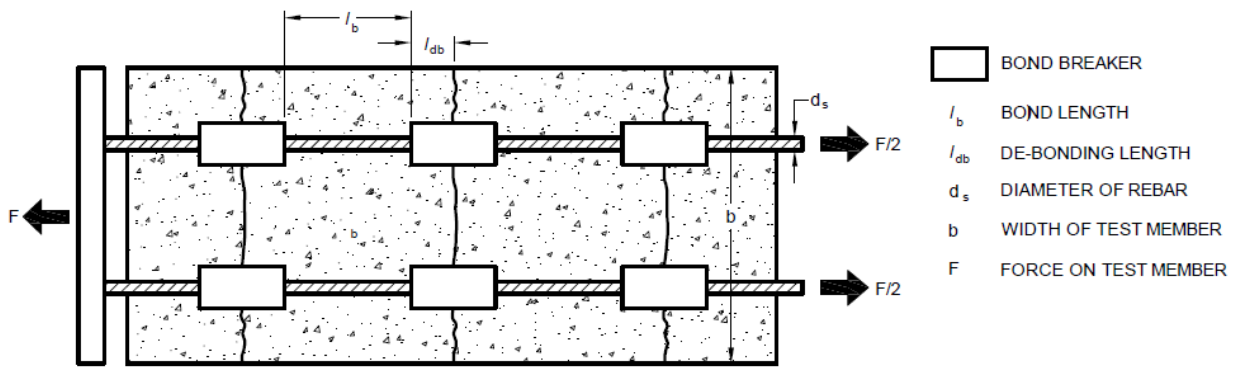

8A Typical cracked concrete test member for crack cycling test

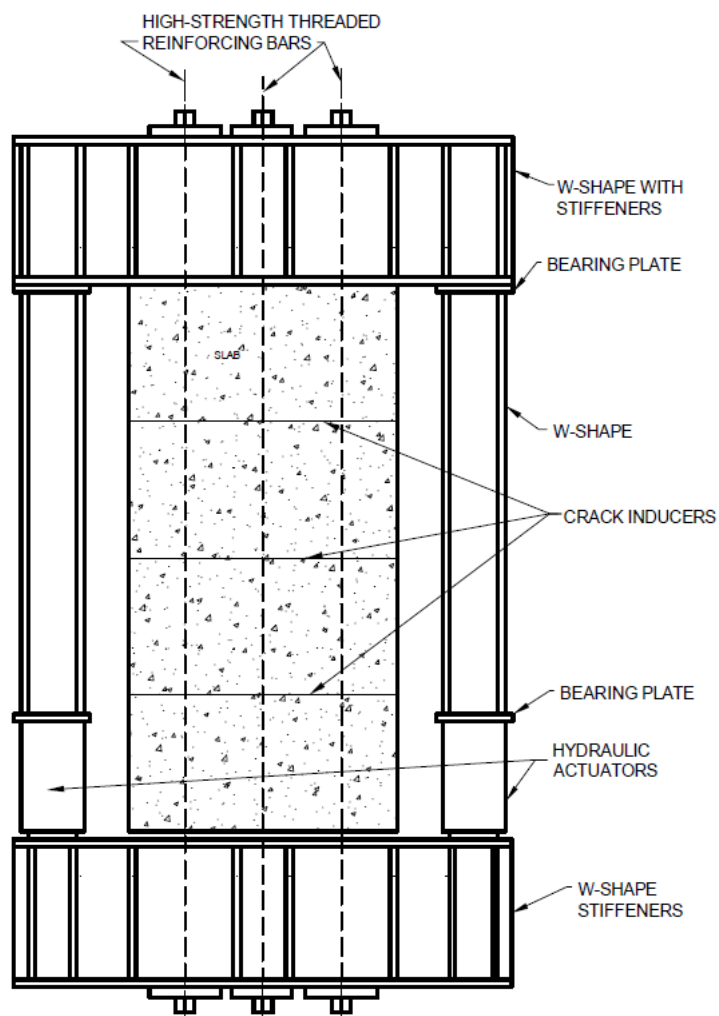

8B Typical test set up for crack cycling

FIG. 8 TYPICAL CRACKED CONCRETE TEST MEMBER AND TEST SET UP FOR CRACK CYCLING

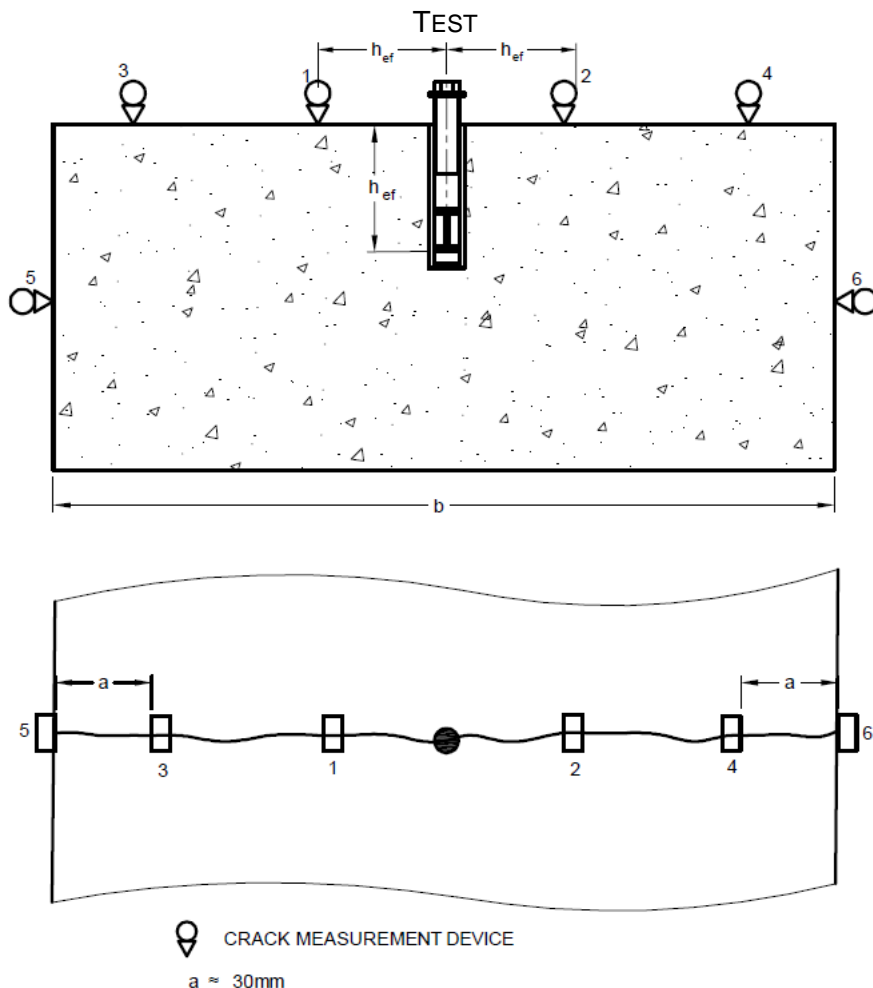

FIG. 9 ILLUSTRATION OF PLACEMENT OF CRACK MEASURING DEVICES TO VERIFY UNIFORM CRACK WIDTH

6.5 Anchor Specimen

6.5.1 Sampling and Selection of Test Specimen

The anchor samples including bolts, nuts and washers for test shall be selected such that they are representative of regular production of the manufacturer. If the mass production unit of the manufacturer is not established at the time of test, it shall be permitted to use specially manufactured samples, provided it is verified that the anchors subsequently produced conform to the anchors tested, in all respects. The fastening elements, such as screws to be used with internally threaded anchors for test shall be specified by the anchor manufacturer.

NOTE – It may be necessary to use fastening elements like screws of higher strength than standard in some test series in order to achieve concrete cone failure. This shall be permitted if it does not influence the functioning of the anchor and is clearly documented in the test report.

6.5.2 No. of Test Specimen

Minimum of 5 samples per anchor diameter and embedment recommended by manufacturer shall be tested for each test series, unless otherwise noted in the test series.

6.5.3 Anchor Variants for Static Tests

The static tests shall be conducted with all anchor diameters, embedment, steel type, steel grade, production method and drilling method. In some test series, a reduction in anchors diameters to be tested is permitted (see Table 2).

NOTE – In some cases, it shall be permitted to reduce the variants to be tested if it can be technically established that the performance will not change for the variant.

6.5.4 Anchor Variants for Seismic Tests

- a) All anchor diameter for which seismic qualification is sought shall be tested. The tests for seismic evaluation in tension shall be conducted with anchor with most adverse head configuration for all steel types, steel grades, production methods and drilling methods for which seismic qualification is sought. If it is not possible to establish the most adverse head configuration, then all head configurations shall be tested. All tests shall be performed with anchors with a steel strength not smaller than nominal value of f_u .

NOTE – If corresponding reference tension tests was not performed for static evaluation then they shall also be conducted. Alternatively, it shall be permitted to calculate resistance from data obtained from tests in cracked concrete for static conditions.

- b) Depending on anchor type, the number of variants to be tested may be reduced if the requirements of **6.4** are fulfilled. In this case, the displacements measured for variant that is tested shall be applied to other variants (that is, different steel types, steel grades and production method).
- c) The variants (that is, different steel types, steel grades and production method) to be tested in tension for seismic evaluation for torque-controlled expansion anchors may be reduced if the following conditions are fulfilled and the reduction factor for seismic determined according to **8.4** for the variant tested (one steel type, highest steel grade and one production method) is accepted for all variants:
- 1) The geometry of anchor variants is identical.
 - 2) The pre-stressing forces at $0.5T_{inst}$ and $1.0T_{inst}$ are statistically equivalent for the variants
NOTE – The installation torque may be different for the variants.
 - 3) For anchors made out of same material, the requirement of the identical internal friction between cone & sleeve and identical external friction between concrete and sleeve, shall be considered to be fulfilled for the variants. if they have same coating and the properties like surface roughness, hardness of the cone and sleeve are statistically equivalent. For anchors made out of different material, this requirement shall be considered to be fulfilled if they have identical coating (provided the internal friction between cone and sleeve is dependent on coating) and the properties like surface roughness, hardness of the cone and sleeve are statistically equivalent.
- d) All variants for which the above requirements are not fulfilled shall be tested. For example, if the above requirements are fulfilled for all steel types and steel grades but not for production methods then the anchors of different production method shall be tested. For torque-controlled expansion anchor variants with similar but not identical

geometry, the variants to be tested in tension for seismic evaluation may also be reduced if in addition to the requirements in **6.5.4** (b) and (c), the following is fulfilled:

- 1) The variant for which the seismic tests are sought to be omitted has been assessed for static load conditions in cracked concrete.
- 2) Its performance in the static load conditions has been found to be better or at least equal to the variant that is being tested and has also exhibited same stiffness in the load-displacement curves
- 3) It has been established that the variant is more ductile than the one that is being tested
- 4) The seismic resistance of this variant is determined as minimum of characteristic resistance in pullout for both variants multiplied by reduction factor α_N for variant that is being tested for seismic conditions.

NOTE – If the highest steel grade of anchor is tested then pull-out failure may be decisive. If the lowest steel grade of anchor is tested then steel failure may be decisive and the corresponding seismic performance may be relevant.

- e) For undercut anchors, only anchors of one steel type, highest steel grade and one production shall be tested in tension if undercut of concrete is identical in all variants for full and partial expansion during tests for robustness to installation (Test Series 12). For undercut anchors that demonstrates follow up expansion during loading shall comply with requirements listed in **6.5.4** (b) and (c) for torque-controlled anchors. If these requirements are not fulfilled for undercut anchors, then all variants shall be tested. If the reduction factors α_N and $\beta_{cV,N}$ due to pulsating tension test determined according to **8.4** are adopted for all anchors then only the anchor with minimum undercut for full expansion may be tested.
- f) For displacement-controlled expansion anchors, no reduction in number of variants shall be permitted in tension tests.
- g) The tests for seismic evaluation in shear shall be conducted with most adverse head configuration and most adverse drilling method for all steel types, steel grades and production method for which seismic qualification is sought. The anchor made of galvanized steel of highest grade and lowest rupture elongation need to be tested, only if the reduction of characteristic steel shear strength due to alternating shear testing as compared to static loading is accepted for all steel types and steel grades.
- h) If multiple embedment depths are recommended by manufacturer for an anchor diameter, it shall be permitted to test only maximum embedment in tension tests provided that the reduction factors for seismic loading α_N and $\beta_{vF,N}$ after assessment according to **8.4** for maximum embedment are applied to shallower embedment as well. In this case, the displacements measured for anchors with maximum embedment shall be applied to anchors with shallower embedment.
- i) If multiple embedment depths are recommended by manufacturer for an anchor diameter, it shall be permitted to test only minimum embedment in shear tests provided that the reduction factors for seismic loading α_V after assessment according **8.4** for minimum embedment are applied to other embedment depths as well. In this case, the displacements measured for anchors with minimum embedment shall be applied to anchors with longer embedment depths.

NOTES

1 If pry-out failure occurs at minimum embedment then the embedment depth shall be increased to avoid this failure type.

2 The embedment depth shall be selected such that the most unfavorable position with respect to shear plane is accounted for. For example, the shear plane may pass through the smooth shaft or threaded region of the anchor, depending on thickness of the base plate (see Fig. 10).

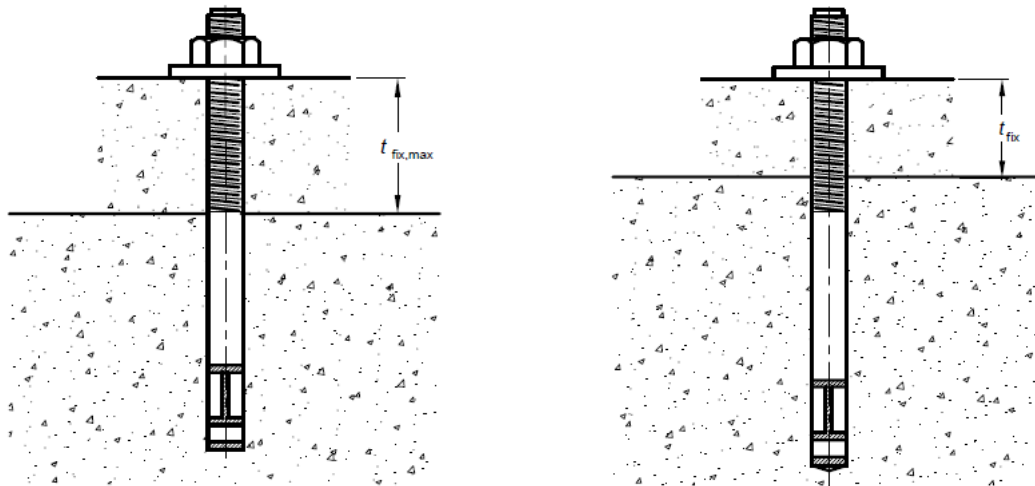

10A Shear plane passing through the smooth shaft of anchor

10B Shear plane passing through the threaded region of anchor

FIG. 10 VARIATION IN SHEAR PLANE OF ANCHOR DUE TO BASE PLATE THICKNESS

6.6 Installation of Anchor Specimen

6.6.1 The anchor specimen for test should be installed in the formed face (that is, the side that has been cast against a form) of the concrete test member unless stated otherwise in the test series.

6.6.2 The anchor specimen shall be placed at a spacing ($s' > s'_{cr,N}$) and edge distance ($c' > c'_{cr,N}$) higher than the critical value, unless otherwise noted in the test series. Critical spacing shall be taken as $3h_{ef}$. The critical edge distance $c'_{cr,N}$ shall be taken as $0.5s'_{cr,N}$.

6.6.3 The anchor samples shall be located from edge such that the test results are not influenced by the minimal reinforcement provided for handling.

6.6.4 The anchor specimen shall be installed according to manufacturer's printed installation instruction (MPII), unless stated otherwise in the test series.

6.6.5 The holes to be drilled for anchor installation shall be perpendicular to the surface of the concrete member; with maximum permissible deviation of $\pm 5^\circ$. The drilling should be performed in slab in floor direction. In the tests, the drilling tools including drill bit / core bit type specified by the manufacturer for the anchor specimen shall be used. The cutting diameter d_{cut} of drill bit shall be of medium tolerance range, unless stated otherwise in the test series. The cutting diameter of drill bit as a function of the nominal drill bit diameter is given in Fig. 11.

6.6.6 The diameter of the drill bit shall be checked every 10 drilling operations to ensure continuous compliance.

6.6.7 If use of special drill bits like stop-drills, hollow drill bits or diamond core drill bits is recommended by the anchor manufacturer for anchor installation then the anchor manufacturer shall specify the dimensions and tolerances of the bits, as no standards on the specification of these products are available. In this case, the tests shall be performed with drill bits within the specifications provided by manufacturer. The definition of a medium cutting diameter ($d_{cut,m}$) for such cases should be laid down by the third party testing laboratories.

6.6.8 For test in cracked concrete test member, the anchor specimen shall be placed in the middle of hairline cracks of the test member. The anchor shall be located in crack over the entire load transfer length.

NOTE – A borescope may be used to verify the crack prior to anchor installation.

6.6.9 For anchors that require application of a defined torque T_{inst} for functioning: To account for relaxation of the prestressing force with time, after about 10 minutes of applying defined torque, the torque moment shall be reduced to $0.5T_{inst}$, prior to testing. The torque moments, when applicable, shall be applied to the anchor by a torque wrench. The measuring error shall not exceed 5 percent of the applied torque. Anchors that do not require application of a defined torque moment, shall not be torqued before testing.

6.6.10 For torque test, double-sided abrasive material shall be inserted between washer and fixture so that the washer does not turn w.r.t. the fixture while torquing (see Fig. 6).

6.6.11 Displacement controlled expansion anchors shall be set with reference expansion (see Annex B) for reference tests.

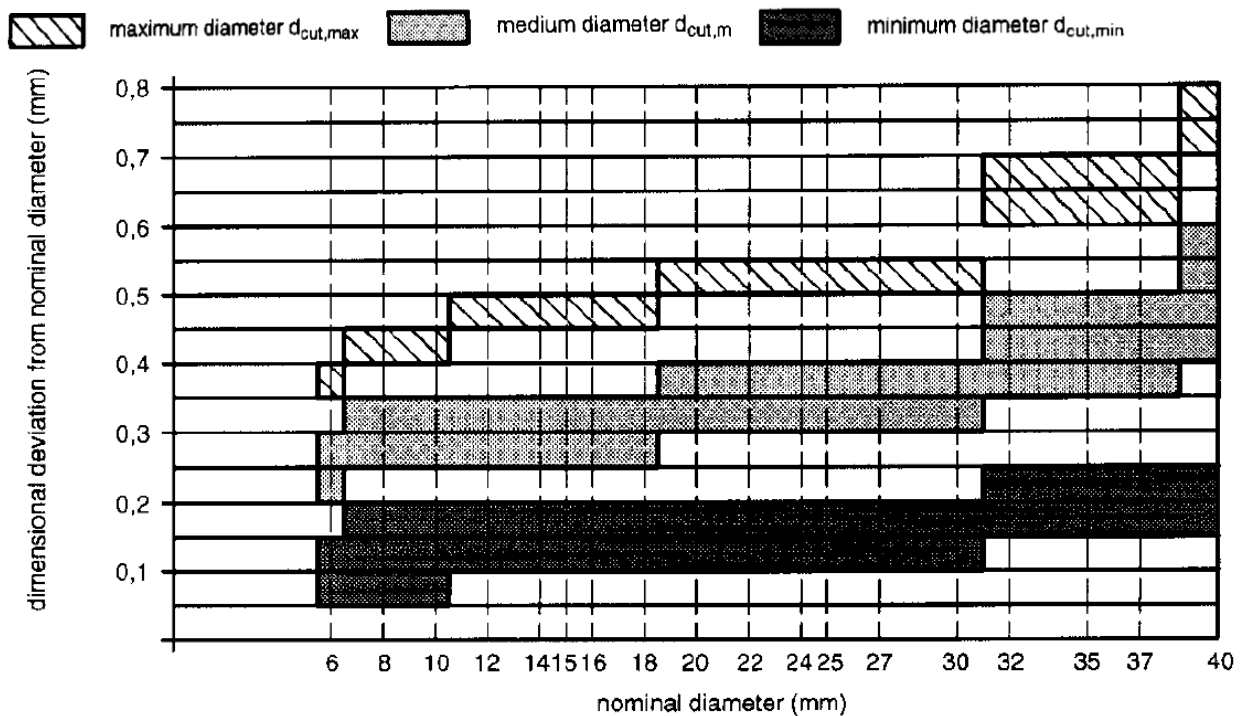

FIG. 11 TOLERANCE OF CUTTING DIAMETER OF HARD METAL HAMMER-DRILL BITS

6.6.12 For testing robustness of anchors to variation in use conditions, the following deviations from standard installation conditions shall apply:

- a) Torque-controlled anchors shall be installed only with half the value of installation torque recommended by manufacturer (that is $0.5T_{inst}$). Drill bits of $d_{cut,m}$ tolerance range shall be used.
- b) Displacement-controlled anchors shall be installed only with reduced expansion (see Annex B) Drill bits of $d_{cut,m}$ tolerance range shall be used.
- c) Undercut anchors shall be installed such that minimum bearing area is achieved. This requirement shall be considered satisfied if the following test conditions are fulfilled depending on type of undercut anchor (see Fig. 12 and Annex C):

1) Displacement-controlled installation:

- i) Anchor installation according to Type I
 - Diameter of drill bit for cylindrical hole $d_0: d_{cut,max}$
 - Length of drill bit for cylindrical hole: maximum length according to specified tolerances
 - Diameter of drill bit for undercutting $d_1: d_{cut,max}$
 - Installation of anchor flush with the concrete surface or the base plate.
- ii) Anchor installation according to Type II
 - Diameter of drill bit for cylindrical hole $d_0: d_{cut,max}$
 - Diameter of drill bit for undercutting $d_1: d_{cut,max}$
 - Displacement of expansion element shall be defined depending on anchor design either as a function of the required displacement, if the full anchor displacement can easily be recognized (for example, by indentation of the anchor sleeve by the setting tool) or as a function of the required input energy for full anchor expansion or as a combination of both.
- iii) Anchor installation according to Type III
 - Diameter of drill bit for cylindrical hole $d_0: d_{cut,max}$
 - Diameter of drill bit for undercutting $d_1: d_{cut,max}$
 - Expansion displacement depends on the installation tools. If the expansion can be done only with a special installation tool and the required expansion displacement can easily be recognized, then the actual expansion displacement shall reflect the possible tolerances.
- iv) Installation according to Type IV and V
 - Diameter of drill bit for cylindrical hole $d_0: d_{cut,max}$
 - Length of drill bit for cylindrical hole: maximum length according to specified tolerances
 - Installation of anchor flush with the concrete surface or the base plate.
 - If it is required by the manufacturer to apply a defined torque moment, then the anchors shall be torqued with T_{inst} and then after about 10 minutes the torque moment shall be reduced to $0.5 T_{inst}$. If no defined torque moment is recommended, then the anchors shall not be torqued before testing (that is, $T_{inst} = 0$).

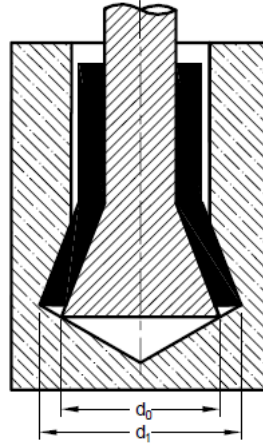

FIG. 12 DIAMETER OF DRILL BIT FOR CYLINDRICAL (d_0) HOLE AND FOR UNDERCUTTING (d_1)

2) Torque-controlled installation:

i) Installation by torque control according to Type I and II

- Diameter of drill bit for cylindrical hole d_0 : $d_{cut,max}$
- Torque moment $0.5T_{inst}$
- Standard and high strength concrete

d) Concrete screws shall be installed such that the tests are performed with minimum mechanical interlock by ensuring the drill hole diameter d_0 is as follows:

$$d_0 \geq d_{cut,max} + (d_{t,t} - d_{t,low})$$

where

$d_{t,t}$ = The outer diameter of the thread in the main load bearing section of the screw during test, and

$d_{t,low}$ = The lower limit of the outer diameter of the thread in the main load bearing section of the screw as per specification of the manufacturer.

6.6.13 For testing the robustness of anchors in contact with reinforcement, the following deviations from standard installation conditions shall apply: The concrete specimen shall be reinforced with 25 mm diameter (\emptyset) reinforcement bars at a spacing of at least 150 mm. The concrete cover is to be maintained at $(h_{ef} - \emptyset/2)$. The anchors shall be installed as per MPII except for proximity with the reinforcement bar. When drilling the hole in concrete, the drilling tool shall be positioned such that the reinforcement bar is clearly cut. The average depth of the notch shall be 1 mm.

6.6.14 For repeated load test for concrete screws, the following deviations from standard installation conditions shall apply: The concrete screw anchors shall be installed on beveled washers (inclination $\geq 4^\circ$) according to MPII. The corner of the hexagonal nut shall rest on the beveled washer. When the installation torque is applied, the anchor head may be somewhere between reaching the beveled washer or fully pressed against the washer. If the manufacturer applies for different head forms, the anchor with the most unfavorable head form shall be tested.

7 TEST CONDITIONS AND PROCEDURE

7.1 General Test Conditions

7.1.1 Test and Assessment Options – Seismic (Option A), Cracked concrete assessment (Option B) and Uncracked concrete assessment (Option C) are covered by this standard. Test regime in Table 2 shall apply for the selected assessment option. For Seismic Option, qualification for use in cracked concrete is a prerequisite.

7.1.2 Test specimen – Anchors shall be installed as per MPII, unless stated otherwise in the test series, in concrete test member of specified concrete strength and cracked conditions defined for the test series.

7.1.3 Temperature – The tests shall be performed at ambient temperature of 23 ± 5 °C, unless stated otherwise in the test series.

7.1.4 Loading Rate – The rate of loading shall be controlled such that the peak load occurs after 1 to 3 minutes from commencement of test.

7.1.5 Load and Displacement Measurement Frequency

The load and displacement data shall be recorded either continuously or at least in about 100 intervals or data points. Load, displacement, or hydraulic control shall be used for test. In case of displacement control, the test should be continued up to at least 75% of the maximum load expected to allow the drop of the load-displacement curve for recording purpose.

7.1.6 Displacement Measurement in Tension Tests

The displacements of the anchor relative to the concrete surface shall be measured by use of either one displacement transducer on the head of the anchor or at least two displacement transducers on either side placed at a distance of greater than or equal to $1.5h_{ef}$ from the anchor; the average value shall be recorded in the latter case.

7.1.7 Displacement Measurement in Shear Tests

The displacements of the anchor relative to the concrete shall be measured in the direction of the load application. This may be accomplished by use of a displacement transducer fixed behind the anchor, seen from the direction of load application, on the concrete.

7.1.8 Crack Width Measurement

The average of measured crack width for each test series for each anchor shall be equal to or greater than the specified crack width for the test series. The individual crack width achieved shall be within the following tolerance:

- a) 20 percent of crack width specified for the test series for $\Delta w < 0.3$ mm
- b) 10 percent of crack width specified (but not more than 0.04 mm) for the test series for $\Delta w \geq 0.3$ mm

The average of crack width of a test series, however, shall reflect the required value. The crack width shall be controlled while the anchor is subjected to load, either:

- a) At a constant width, for example, by means of a servo system, or
- b) Limited to a width close to the specified value by means of appropriate reinforcement and depth of the test member.

Use only one sided tolerance for crack width.

Irrespective of the method used, the crack width at the face opposite to that in which the anchor is installed should be maintained close to the specified value.

In case of static tension test, the crack widths shall be measured at a distance of approximately h_{ef} from anchor (or as close as possible but not at a distance greater than 150 mm from the anchor) and at least on the face of the test member in which the anchors are installed.

In case of static shear test, the crack widths shall be measured at a distance of approximately h_{ef} behind the anchor (seen from the direction of load application) and the load shall be applied in the direction of the crack towards the edge.

For pulsating tension tests, the crack width shall be measured using devices placed at locations as illustrated in Fig. 9.

For alternating shear tests, the crack width shall be measured within a distance of h_{ef} in front & behind of the anchor or directly on anchor location, if possible.

7.2 Steel Capacity Test

This test is performed to determine the characteristic resistance to steel failure. This test may be omitted in case the steel strength of the product can be determined easily (constant diameter and constant steel strength).

7.2.1 For anchors installed in concrete, steel capacity test shall be conducted with a confined/unconfined test set up (as applicable based on the type of anchor) in high strength concrete.

7.2.2 Alternatively, this test should be performed on finished anchor product to determine characteristic resistance to steel failure. Universal testing machine should be used to determine the steel capacity of the anchor. Special fixtures may be required to hold the anchor in position for testing. The load and elongation percentage (if applicable) shall be recorded.

7.3 Maximum Installation Torque Moment Test

This test is performed to verify that the application of installation torque will not result in steel failure of the bolt. Torque test set up according to **5.7** shall be used. The installed anchor specimen shall be torqued with a calibrated torque wrench until torque cannot be increased further or at least to $1.3T_{inst}$. The tension force in the bolt shall be measured as a function of the applied torque moment. The connection should be unscrewed at the end of the test to check if it is possible to remove the nut.

7.4 Hydrogen Embrittlement Test

This test is performed to determine the susceptibility of concrete screws to hydrogen induced brittle failure caused by production process or by corrosion during exposure to moisture. For the purpose of the test, an electrolyte solution (for example, calcium hydroxide solution) should be applied while the sample is kept under constant potential by means of a reference electrode. (see Fig. 13). The test may be omitted if the concrete screws are made of stainless steel, or it can be ensured during production that the strength of steel at the area of load transfer is less than 1000 N/mm^2 and hardness is smaller than 350 HV.

7.4.1 The tests shall be performed with the most adverse head form. If it is not possible to establish the most adverse head form, then all head forms shall be tested.

7.4.2 The concrete screws, intended to be tested, shall require the galvanization coating to be removed partially without damaging the surface of the screw to allow hydrogen evolution on the surface.

7.4.3 For the test, the saturated solution (in distilled or deionized water with conductivity not higher than $20 \mu\text{S}/\text{cm}$ at $25^\circ\text{C} \pm 2^\circ\text{C}$) of calcium hydroxide shall be filled into a bottomless container covering an area of 96 cm^2 with a height of 25 mm, which shall be connected to the concrete. The pH value shall be maintained constant at 12.6 at 25°C . The potential shall be maintained at -955 mV vs. normal hydrogen electrode. Any kind of second order electrode may be used (calomel/ silver/silver chloride). The potential value shall be corrected according to the reference value provided by the manufacturer. Stainless steel or activated titanium may be used as anode for cathodic protection. The screw shall be subjected to a sustained loading for a duration of 100 hours. During the test duration, the anchors shall not fail. In case concrete failure occurs, the test shall be repeated. After unloading the screw, an unconfined tension test shall be performed to check the residual load capacity. The load displacement behavior and variation shall be recorded.

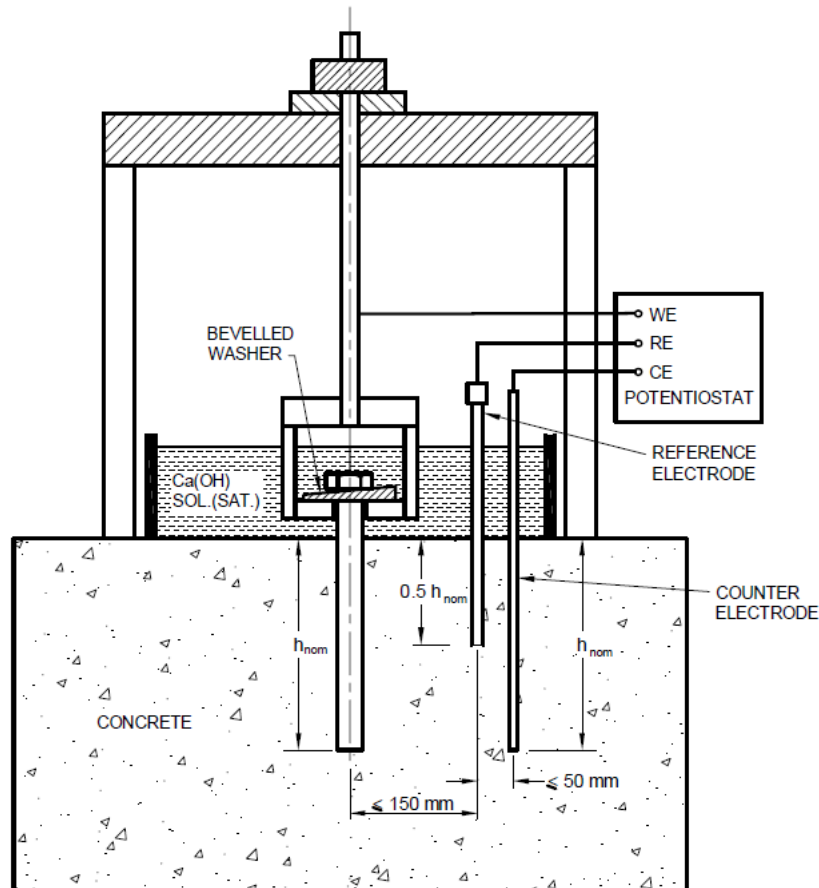

FIG. 13 SCHEMATIC OF TEST SET UP FOR HYDROGEN EMBRITTLEMENT TEST

7.5 Unconfined Tension Test

This test is performed to determine pull-out strength in unconfined set up. After the anchor is installed as required, it shall be connected to the loading device and pulled in tension to failure using unconfined tension test set up as per 5.4. In case of tests in cracked concrete, the cracks shall be opened to specified crack width after anchor installation, prior to testing. The load displacement behavior and variation shall be recorded.

7.5.1 For critical edge distance test to prevent splitting under load, the unconfined tension test setup shall be placed such that an unrestricted concrete failure towards the edge is possible. As the anchor is located in corner in this test, the test setup should be supported outside the test member (see Fig. 14).

Commentary - For sleeve down type displacement-controlled anchors, the position of the sleeve in relation to the cone is not visible after installation. This "Robustness of sleeve down type DC anchor test" determines the robustness of sleeve down type fasteners.

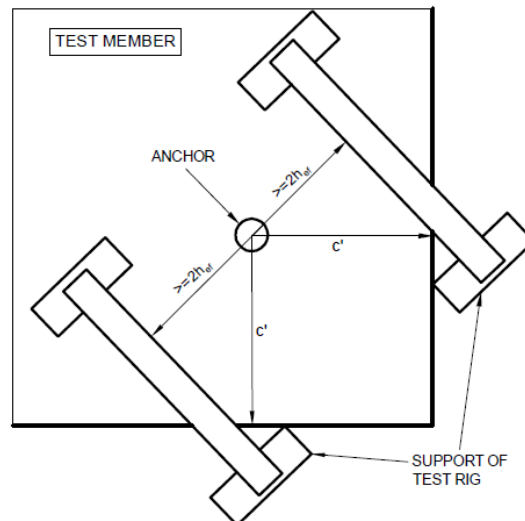

FIG. 14 SCHEMATIC OF TENSION TEST SET UP FOR CORNER TEST

7.5.2 For robustness of anchors to variation in use conditions test, the following measurements shall also be performed, and the results shall be recorded for displacement-controlled and torque-controlled installations of undercut anchor:

- a) Displacement-controlled Installation
 - 1) Length of the stop drill (if used)
 - 2) Dimensions of the drill bit for undercutting the concrete (if used)
 - 3) Position of the sleeve in relation to the concrete surface (pre-positioned installation) or the fixture (in- place installation), after anchor expansion and after the torque moment is applied, if applicable.
 - 4) Expansion displacement (relative displacement between sleeve and cone during expansion)
- b) Torque-controlled Installation
 - 1) Dimension of the drill bit for undercutting the concrete
 - 2) Position of sleeve in relation to the concrete surface (pre-positioned installation) or the base plate (in-place installation), after the torque moment is applied.
 - 3) Number of revolutions required by the nut or bolt to achieve applied installation torque moment as required by the manufacturer.

7.6 Crack Cycling Test

This test is performed to ensure effective functioning of anchor in sustained tension in cracked concrete when width of crack is fluctuating in the range covered by this standard.

7.6.1 In the crack cycle test, the anchor shall be subject to crack width fluctuations within a defined range. The maximum load (max N_{TM}) and minimum load (min N_{TM}) for load cycle to be applied to the test member after anchor installation, shall be determined such that the crack width under max N_{TM} is $\Delta w_1 = 0.3$ mm and under min N_{TM} is $\Delta w_2 = 0.1$ mm. Up to 10 load cycles varying between max N_{TM} and min N_{TM} should be applied to the test member to stabilize crack formation.

7.6.2 A tensile load N_{sus} determined according to the following equation shall be applied to the anchor after opening the crack to $\Delta w_1 = 0.3$ mm (opening crack width). N_{sus} shall remain constant during the test with a tolerance of $\pm 5\%$:

$$N_{sus} = 0.5 N_{Rk,cr',ts6} / \gamma_{inst}$$

where

- $N_{Rk,cr',ts6}$ = Characteristic tensile strength determined from Test Series 6 by normalizing $N_{u,5\%,ts6}$ to 25 MPa
- γ_{inst} = partial safety factor for installation (see CED 2(0097)WD)

7.6.3 After N_{sus} is applied, the anchor shall be subjected to 1000 crack cycles (for assessment of 50 years' service life) as applicable, with a frequency of approximately 0.2 Hz. During opening of the cracks, the crack width Δw_1 shall be kept approximately constant (see Fig. 15); for this purpose, the max N_{TM} load applied to the test member may have to be reduced. The min N_{TM} load shall be kept constant.

Commentary – As min N_{TM} load is kept constant the crack width Δw_2 may increase during the test

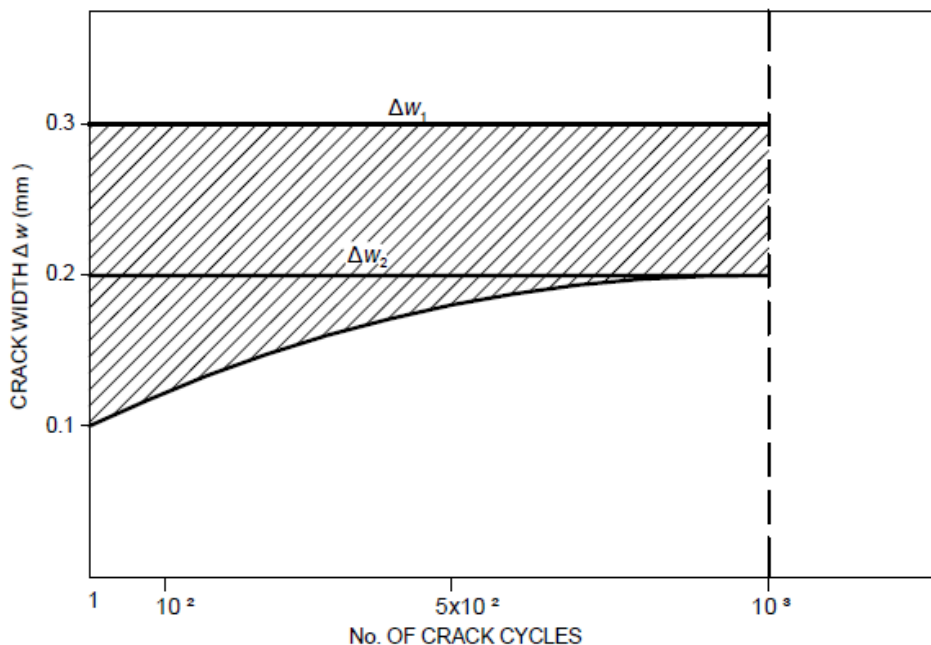

FIG. 15 ALLOWABLE CRACK OPENING VARIATIONS DURING CRACK CYCLING TEST

7.6.4 The difference in crack width $\Delta w_1 - \Delta w_2$, shall be maintained at least ≥ 0.1 mm during the crack cycling. If this condition cannot be satisfied with $\Delta w_1 = 0.3$ mm, then either min N_{TM} should be reduced or Δw_1 should be increased accordingly.

7.6.5 The load-displacement behavior shall be measured up to the load N_{SUS} . Afterwards under constant load N_{SUS} , the displacement of the anchor and the crack widths Δw_1 and Δw_2 shall be measured either continuously or at least after 1, 2, 5, 10, 20, 50, 100, 200, 500 and 1000 crack cycles. The load-displacement behavior during crack cycling shall be recorded.

7.6.6 At the end of the crack cycle test, the anchor shall be unloaded, and the displacement shall be measured. A tension test (i.e., residual load test) to failure, with $\Delta w = 0.3$ mm, shall be conducted in accordance with **5.4**, after completion of the crack cycling. The load displacement behavior and variation for residual load test shall also be recorded.

7.7 Repeated load test

This test is performed to determine influence of repeated load on anchor behavior which simulate service loads that are subject to variation over time.

7.7.1 After anchor installation, the anchor shall be subjected to 10^5 load cycles (assessment for 50 years' service life), with a maximum frequency of 6 Hz approx.

7.7.2 During each load cycle, the tensile load applied on anchor shall change as a sine curve between N_{max} and N_{min} determined according to the equations given below:

$$N_{max} = \text{minimum of } 0.6 N_{Rk,uncr'} \text{ and } 0.8 A_s f_y$$

$$N_{min} = \text{maximum of } 0.25 N_{Rk,uncr'} \text{ and } (N_{max} - A_s \cdot \Delta\sigma_s)$$

where

$N_{Rk,uncr'}$ = Characteristic tensile strength determined by normalizing $N_{u,5\%,ts4}$ (for low) or $N_{u,5\%,ts5}$ (for high) to 25 MPa, corresponding to low or high strength concrete used for this test series, and

$$\Delta\sigma_s = 120 \text{ N/mm}^2$$

7.7.3 The displacements shall be measured during the first loading up to N_{max} and then either continuously or at least after 1, 10, 10^2 , 10^3 , 10^4 and 10^5 of repeated load cycles, as applicable.

7.7.4 At the end of the load cycle, the anchor shall be unloaded, and the displacement shall be measured. A tension test (i.e., residual load test) to failure shall be conducted in accordance with **5.4**, after completion of the load cycle. The load displacement behavior and variation for residual load test shall be recorded.

7.8 Ultimate Torque Test

This test is performed to ensure that failure of concrete screws does not occur during installation (torquing).

7.8.1 Torque Test with Calibrated Torque Wrench

After the anchor is torqued to the installation torque (T_{inst}), the torque shall be gradually increased till failure is observed. The ultimate torque shall be recorded. The test may be omitted if the MPII recommends the use of impact screw driver for setting of the concrete screws.

7.8.2 Torque Test with Impact Screw Driver

The tests shall be performed for the most adverse head form of the anchor. If most adverse head form is not obvious then all head forms shall be tested. The impact screw driver shall be set on the head of the anchor with maximum power output as per MPII. It shall automatically switch off after 5 seconds. Failure, if any, shall be noted. The test may be omitted if the MPII does not recommend the use of impact screw driver for setting of the concrete screws.

7.9 Minimum Edge Distance and Spacing Test

This test is performed to check that splitting of base material does not occur during the installation of anchor at minimum edge and spacing values recommended by manufacturer.

7.9.1 A standard uncracked concrete test member with minimum permissible thickness ($D = D_{min}$) shall be used. If it is necessary to provide edge reinforcement, it shall be permissible to do so, provided this edge reinforcement is stated in the test report and assessment document as a minimum requirement.

7.9.2 An anchor group of two anchor with minimum spacing ($s' = s'_{min}$) is installed at minimum edge distance ($c' = c'_{min}$) as per MPII. The double anchors are placed on the form face of a concrete test member with a distance $\geq 3h_{ef}$ between neighboring groups. In total, 5 such anchor groups shall be tested.

7.9.3 The diameter d_{fix} of the clearance holes in the fixture shall correspond to the values given in Table 1. The fixture shall be $3d_{fix}$ in width, $s_{min} + 3d_{fix}$ in length and d_{fix} in thickness.

NOTE – The edge distance and spacing shall be rounded to at least 5 mm and should not be less than maximum of $4d_o$ and 35 mm. If cracks appear during setting then the edge and spacing shall be increased and the test shall be repeated.

7.9.4 Calibrated torque wrench shall be used to perform this test. The anchors in the anchor group shall be torqued alternately in steps of $0.2 T_{inst}$. After each load step, the concrete surface shall be inspected for cracks. The test shall be stopped when the torque moment cannot be increased further. The number of revolutions per load step shall be measured for both anchors. Furthermore, the torque moment at the formation of the first hairline crack at one or both anchors and the maximum torque moment that can be applied to the two anchors shall be recorded.

7.10 Shear Test

This test is performed to determine characteristic strength of an anchor in shear without edge and spacing influence. This test shall be required only if the distribution of steel strength along the length of the finished product cannot be easily determined. After the anchor is installed as required, it shall be connected to the shear test set up in accordance with **5.5**. There should be no gap between the anchor and the interchangeable sleeve/ fixture in the loading plate. The anchor shall be then loaded in shear to failure. The load displacement behavior and variation shall be recorded.

NOTE - In case different embedment depths are recommended for specific anchor diameter, the most unfavorable condition shall be tested. In addition, the most unfavorable cross section shall be considered.

7.10.1 For reference tests (Test Series S3) to determine strength of anchor in shear in standard cracked concrete without edge and spacing influence for seismic evaluation the shear set up as per **5.4** shall be used. If different embedment depths are recommended for

specific anchor diameter, the most unfavorable condition shall be tested. If the failure is caused by pull-out of anchor then the tests shall be repeated with longer embedment till these failure types are avoided.

NOTE – This test series may be omitted if the tests according to reference shear test are performed. In this case, the steel properties of reference shear test shall be used for normalizing results of Test Series S5.

7.11 Pry-out Test

The test is performed to determine the response of an anchor to pry-out failure. The test is performed with a group of four anchors installed in standard uncracked concrete. The spacing to be maintained as $s = s'_{cr,N}$ and edge distance $c \geq c'_{cr,N}$. After the anchor is installed, it shall be connected to the shear test set up in accordance with 5.5. The anchor shall be then loaded in shear to failure. The load displacement behavior and variation shall be recorded. If steel failure is observed in the test, the spacing shall be reduced.

7.12 Pulsating tension tests

This test is performed to determine strength of anchor in tension in standard cracked concrete without edge and spacing influence for seismic evaluation.

7.12.1 For this test, anchors shall be installed in standard cracked concrete test member for seismic tests (with $\Delta w = 0.5$ to 0.8 mm) in accordance with 6.4. After the anchor is installed, the crack shall be opened to 0.5 mm.

7.12.2 The anchor shall be then connected to the loading device and subjected to sinusoidal tension loads as recommended in Table 3 and as illustrated in Fig. 16, with load cycling frequency less than or equal to 0.5 Hz.

7.12.3 The crack width shall be increased to 0.8 mm after completion of $0.5 N/N_{max}$ load level cycle. The crack width shall be controlled during load cycle.

7.12.4 To avoid servo control problems, the bottom of tension load pulses may be taken to a value slightly greater than zero but less than maximum of $0.02N_{max}$ and 200 N.

7.12.5 The maximum load of tension load cycle shall be determined using the following equations depending on the failure type observed in Test Series S1. If mixed failure type occurred in Test Series S1 then the largest value of the following equations shall be used.

$$N_{max} = \left[\begin{array}{ll} 0.75N_{u,m,ts,S1} (f_{u,ts,S4}/f_{u,ts,S1}) & \text{For steel failure} \\ 0.75N_{u,m,ts,S1} (f_{cm,ts,S4}/f_{cm,ts,S1})^{0.5} & \text{For all other failure types} \end{array} \right]$$

where

$N_{u,m,ts,S1}$ = Mean ultimate load in tension from Test Series S1,

$f_{u,ts,S4}$ = Mean ultimate steel strength of anchor being used in Test Series S4.

$f_{u,ts,S1}$ = Mean ultimate steel strength of anchor used in Test Series S1,

$f_{cm,ts,S4}$ = Mean compressive strength of the concrete test member at the time of anchor testing in Test Series S4,

$f_{cm,ts,S1}$ = Mean compressive strength of the concrete test member at the time of anchor testing in Test Series S1, and

n' = Normalization factor to account for concrete strength.

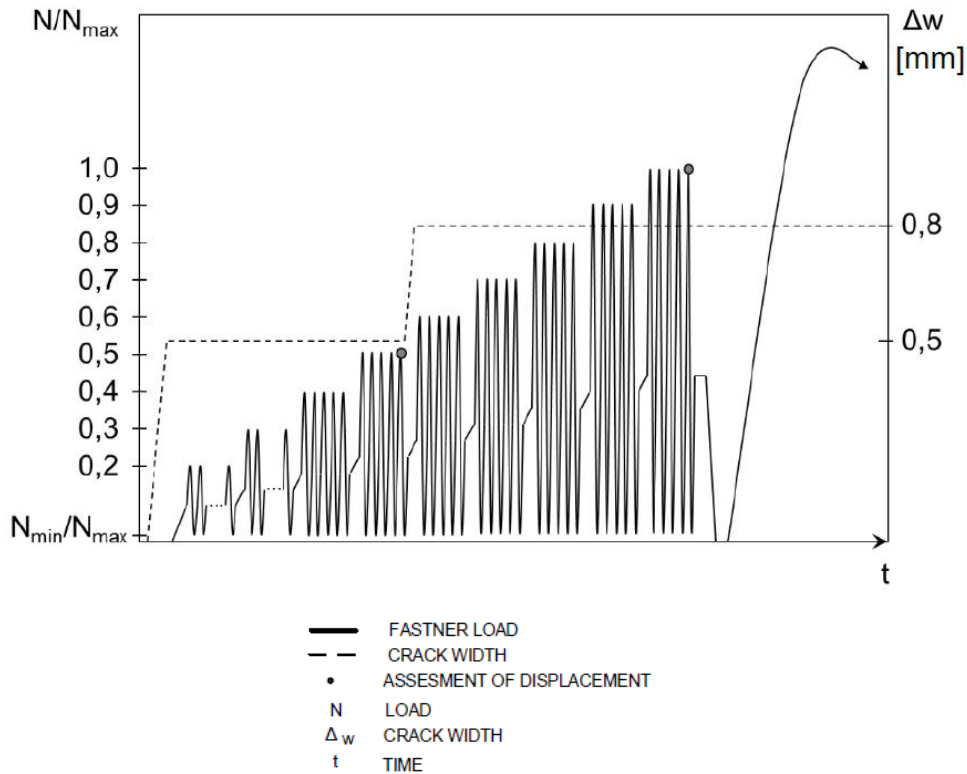

FIG. 16 VARIATION IN TENSION LOAD AMPLITUDE WITH NO. OF CYCLES

Table 3 Variation in Tension Load Amplitude with No. of Cycles
(Clause 7.12.2)

SI No.	N/N_{max}	No. of tension cycles	Variation in crack width Δw with no. of tension cycles (mm)
(1)	(2)	(3)	(4)
i)	0.2	25	0.5
ii)	0.3	15	0.5
iii)	0.4	5	0.5
iv)	0.5	5	0.5
v)	0.6	5	0.8
vi)	0.7	5	0.8
vii)	0.8	5	0.8
viii)	0.9	5	0.8
ix)	1	5	0.8
	Total	75	

7.12.6 The anchor shall be unloaded after completion of the tension load cycles and the dimension of crack width shall be checked.

7.12.7 If the crack width decreases during the unloading of anchor then it shall be again opened to 0.8 mm. The residual capacity of anchor shall be then determined by conducting a pullout test to failure using unconfined test set up.

Commentary – The test may be conducted with crack width of 0.8 mm for all load levels. Triangular load cycles may be used instead of sinusoidal load cycles.

NOTE – If anchors from same production lot are used for Test Series S1 and this test then no normalization shall be required when calculating using following equation.

7.12.8 The anchor displacement, crack width and the applied tension load cycle shall be continuously recorded using a data acquisition system. The displacement at maximum and minimum load cycles shall be plotted as a function of no. of load cycles.

7.12.9 The load displacement behavior and variation of residual tension load test shall be recorded.

7.13 Alternating Shear Tests

This test is performed to determine strength of anchor in shear in standard cracked concrete without edge and spacing influence for seismic evaluation.

7.13.1 For this test, anchors shall be installed in standard cracked concrete test member for seismic tests (with $\Delta w = 0.8$ mm) in accordance with **6.4**.

7.13.2 Shear test set up for alternating shear in accordance with **5.6** shall be used for testing. After the anchor is installed, the crack shall be opened to 0.8 mm.

7.13.3 The anchor shall be then connected to the loading device and subjected to sinusoidal shear loads as recommended in Table 4 and as illustrated in Fig. 17, with load cycling frequency less than or equal to 0.5 Hz. The load direction shall be parallel to the crack. The crack width shall be controlled during load cycle.

7.13.4 To avoid servo control problems, the bottom of shear load pulses may be taken to a value slightly greater than zero but less than maximum of $0.02V_{max}$ and 200 N. The maximum load of shear load cycle shall be determined using the following equations depending on the location of shear plane.

NOTE – If the anchors in Test Series S3 and S5 are from same production lot then the adjustment for different steel strength is not required in the equation for determining V_{max} .

$$V_{max} = 0.85V_{u,m,ts_S3} (f_{u,ts_S5} / f_{u,ts_S3}) \quad \text{For anchors without sleeve in shear plane}$$

$$V_{max} = 0.85 V_{u,m,ts_S3} \left(\frac{f_{u,bolt,ts_S5} A_{s,bolt}}{f_{u,bolt,ts_S3} A_{s,a}} + \frac{f_{u,sle,ts_S5} A_{s,sle}}{f_{u,sle,ts_S3} A_{s,a}} \right) \quad \text{For anchors with sleeve in shear plane}$$

where

V_{u,m,ts_S3}	= Mean ultimate shear load in shear from Test Series S3
f_{u,ts_S5}	= Mean ultimate steel strength of anchor being used in Test Series S5
f_{u,ts_S3}	= Mean ultimate steel strength of anchor used in Test Series S3
$f_{u,bolt,ts_S5}$	= Mean ultimate steel strength of bolt being used in Test Series S5
f_{u,sle,ts_S5}	= Mean ultimate steel strength of sleeve being used in Test Series S5
$f_{u,bolt,ts_S3}$	= Mean ultimate steel strength of bolt used in Test Series S3
f_{u,sle,ts_S3}	= Mean ultimate steel strength of sleeve used in Test Series S3
$A_{s,bolt}$	= Effective cross-section area of bolt
$A_{s,sle}$	= Effective cross-section area of sleeve

$$A_{s,a} = A_{s,bolt} + A_{s,sle}$$

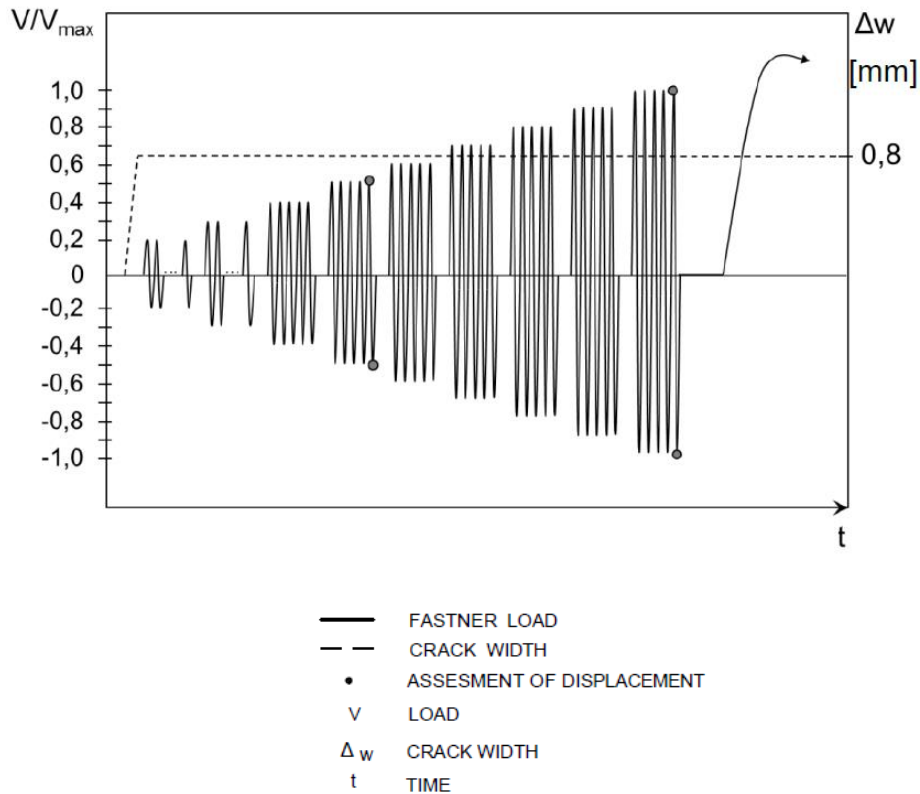

FIG. 17 VARIATION IN SHEAR LOAD AMPLITUDE WITH NO. OF CYCLES

Table 4 Variation in Shear Load Amplitude with No. of Cycles
(Clause 7.13.3)

SI No. (1)	V/V_{max} (2)	No. of shear load cycles (3)	Crack width Δw (mm) (4)
i)	0.2	25	0.8
ii)	0.3	15	0.8
iii)	0.4	5	0.8
iv)	0.5	5	0.8
v)	0.6	5	0.8
vi)	0.7	5	0.8
vii)	0.8	5	0.8
viii)	0.9	5	0.8
ix)	1	5	0.8
	Total	75	

NOTE – To avoid or reduce occurrence of uncontrolled slip during load reversal, an approximation by two half sinusoidal load cycles (connected by a reduced speed & ramped load) or a simple triangular load cycle pattern may be used as illustrated in Fig. 18.

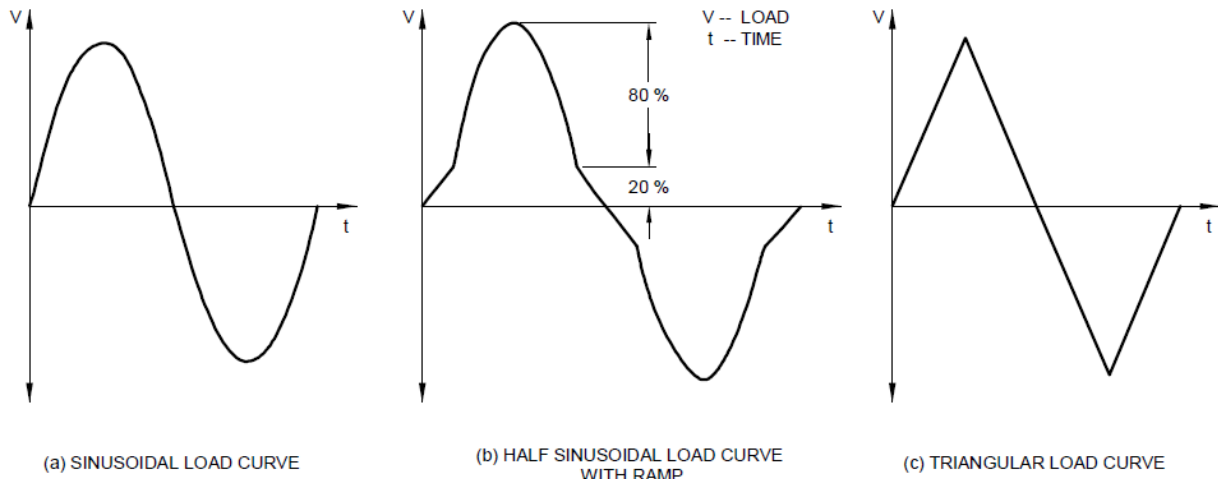

FIG. 18 PERMITTED SHEAR LOAD CYCLE PATTERNS

7.13.5 The anchor shall be unloaded after completion of the shear load cycles and the dimension of crack width shall be checked.

7.13.6 If the crack width decreases during the unloading of anchor then it shall be again opened to 0.8 mm. The residual capacity of anchor shall be then determined by conducting a shear test to failure using shear test set up. If pull-out or pull-through failure occurs then the test shall be repeated with longer embedment depth to avoid these failure types.

7.13.7 The anchor displacement, crack width and the applied shear load cycle shall be continuously recorded using a data acquisition system. The displacement at maximum and minimum load cycles shall be plotted as a function of no. of load cycles.

7.13.8 The load displacement behavior and variation of residual shear load test shall be recorded.

NOTE – During the shear load cycle, failure may occur in embedded portion of the anchor. If such a failure occurs close to the embedded end of the fastener the residual capacity may not be significantly affected. Hence, in this case the failure of anchor may be overlooked. Attention should be paid to this aspect.

7.14 Crack Cycling Test

To determine strength of anchor in tension in standard cracked concrete without edge and spacing influence, when subjected to variation in crack width. This test is used for seismic evaluation.

7.14.1 For this test, anchors shall be installed in standard cracked concrete test members for seismic tests (with $\Delta w = 0.8$ mm) in accordance with 6.4. Only one anchor shall be tested at a time, i.e. no other anchor shall be installed in the same crack.

7.14.2 The load cycles to initiate crack and stabilize crack width w.r.t load applied on test member shall be carried out in accordance with 6, prior to installation of anchor. The initiated hairline crack should be closed by applying a centric compression force on test member in order to create similar initial conditions when either a test member with one crack plane or with multiple crack planes is used. The initial centric compression force, CF_{ini} , (applied prior to anchor installation) shall not be larger than the value given by

$$CF_{ini} = 0.01f_{cm,ts,S6}A_{TM}$$

where

$f_{cm,ts,S6}$ = Mean compressive strength of concrete test member at the time anchor testing in Test Series S6, and

$A_{s,TM}$ = Cross-section area of concrete test member.

7.14.3 The dial gauges for measuring crack width shall be set to zero prior to test. Any slack in loading mechanism shall be removed by application of sufficient load, prior to recording anchor displacements.

7.14.4 After the anchor is installed, it shall be subjected to load N_{w1} . The load N_{w1} shall be determined using the following equations depending on the failure type observed in Test Series S1. If mixed failure type occurred in Test Series S1 then the largest value of the following equations shall be used.

$$N_{w1} = \left[\begin{array}{ll} 0.4N_{u,m,ts,S1} (f_{u,ts,S6}/f_{u,ts,S1}) & \text{For steel failure} \\ 0.4N_{u,m,ts,S1} (f_{cm,ts,S6}/f_{cm,ts,S1})^{0.5} & \text{For all other failure types} \end{array} \right]$$

where

$N_{u,m,ts,S1}$ = Mean ultimate load in tension from Test Series S1

$f_{u,ts,S6}$ = Mean ultimate steel strength of anchor being used in Test Series S6

$f_{u,ts,S1}$ = Mean ultimate steel strength of anchor used in Test Series S1

$f_{cm,ts,S6}$ = Mean compressive strength of the concrete test member at the time of anchor testing in Test Series S6

$f_{cm,ts,S1}$ = Mean compressive strength of the concrete test member at the time of anchor testing in Test Series S1

7.14.5 The anchor with tension load N_{w1} shall be subjected to crack cycle as recommended in Table 5 and as illustrated in Fig. 19, with load cycling frequency less than or equal to 0.5 Hz. The first crack movement shall be in the direction of crack closure achieved by application of compression load on the test member.

7.14.6 During crack cycling, the crack shall be closed (i.e., $\Delta w \leq 0.1 \text{ mm}$) by applying a centric compression force, CF , given by

$$CF = 0.1f_{cm,ts,S6}A_{TM}$$

NOTES

1 The initial crack w_{ini} width after applying the load N_{w1} may exceed the value of 0.1 mm. In this case, the crack cycle is performed starting with $\Delta w = 0.1 \text{ mm}$.

2 The centric compression force, CF , may be increased to a maximum value of $0.15f_{c,ts,S6}A_{TM}$ if it is not possible to achieve crack with value of less than 0.1 mm using the centric compression force of $0.1f_{c,ts,S6}A_{TM}$.

7.14.7 The crack width shall be increased in step by step manner as shown in Table 5. Before starting with crack cycle with width of 0.6 mm, the tension load on the anchor shall be increased to N_{w2} . The load N_{w2} shall be determined using the following equations depending

on the failure type observed in Test Series S1. If mixed failure type occurred in Test Series S1 then the largest value of the following equations shall be used.

$$N_{w2} = \left[\begin{array}{ll} 0.5N_{u,m,ts,S1} (f_{u,ts,S6}/f_{u,ts,S1}) & \text{For steel failure} \\ 0.5N_{u,m,ts,S1} (f_{cm,ts,S6}/f_{cm,ts,S1})^{0.5} & \text{For all other failure types} \end{array} \right]$$

NOTE – If anchors from same production lot are used for Test Series S1 and this test then no normalization shall be required when calculating the load N_{w1} and N_{w2} .

7.14.8 The anchor shall be unloaded after completion of the tension load cycles and the dimension of crack width shall be checked.

7.14.9 If the crack width decreases during the unloading of anchor then it shall be again opened to 0.8 mm. The residual capacity of anchor shall be then determined by conducting a pullout test to failure using unconfined tension test set up.

7.14.10 The anchor displacement, crack width and the applied tension load shall be continuously recorded using a data acquisition system. The displacement at maximum and minimum crack width along with applied tension load shall be plotted as a function of no. of crack cycles.

7.14.11 The load displacement behavior and variation of residual tension load test shall be recorded.

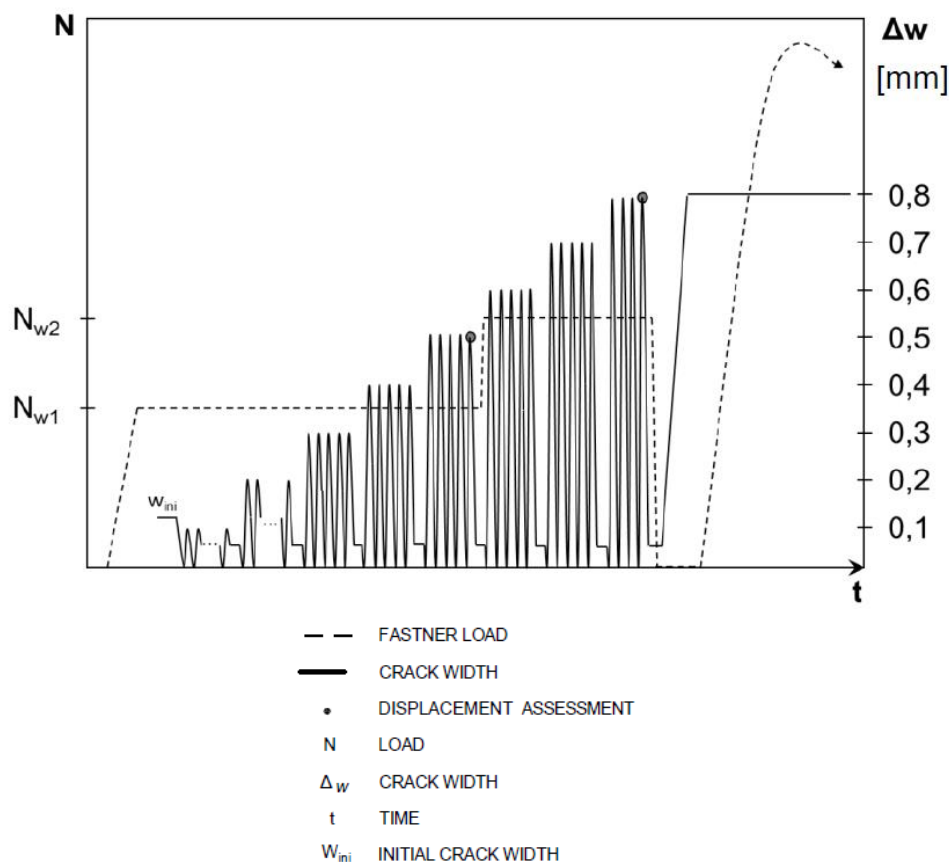

FIG. 19 VARIATION IN CRACK WIDTH WITH NO. OF CYCLES

Table 5 Variation in Crack Width with No. of Cycles

(Clause 7.14.5)

SI No.	Anchor load	No. of crack cycles	Variation in crack width Δw with no. of cycles (mm)
(1)	(2)	(3)	(4)
i)	N_{w1}	20	0.1
ii)	N_{w1}	10	0.2
iii)	N_{w1}	5	0.3
iv)	N_{w1}	5	0.4
v)	N_{w1}	5	0.5
vi)	N_{w2}	5	0.6
vii)	N_{w2}	5	0.7
viii)	N_{w2}	4	0.8
	Total	59	

7.15 Test Report

As a minimum requirement, the report shall include at least the following information.

7.15.1 General

- Type of anchor along with description
- Parameters for anchor identification e.g., dimensions, materials, coating, production method
- Name and address of manufacturer & test laboratory
- Date on which the test was performed
- Name of person responsible for test
- Type and number of tests e.g., tension, shear, short-term or repeated load test
- Test setup, illustrated by sketches or photographs
- Particulars concerning support of test setup on the test member

7.15.2 Test Members

- Grade of hardened concrete
- Composition and properties of fresh concrete e.g., consistency, density, aggregate type etc.
- Date of manufacture/ casting
- Dimension of control specimens, and/or cores (if applicable); measured value of compression strength at the time of testing (individual and average value)
- Dimensions of test member
- Nature and positioning of any reinforcement
- Test face of concrete – form face or cast face

7.15.3 Anchor Installation

- Information on the positioning of the anchor e.g., placed on the formed or cast face of the test member
- Distances of anchors from edges of test member and between adjacent anchors
- Tools employed for anchor installation, e.g., impact drilling tool, drilling hammer, other equipment like torque wrench, etc.
- Type of drill bit, manufacturer's mark, and measured drill bit dimensions, particularly the effective diameter, d_{cut} , of the hard metal drill bit
- Information on the direction of drilling

- f) Information on cleaning of the hole
- g) Depth of drill hole
- h) Width of crack when installing the anchor (where applicable)
- i) Depth of anchorage
- j) Tightening torque or other parameters for control of installation, e.g. penetration depth of the expansion element of displacement controlled anchors
- k) Displacement of anchor at the applied torque moment (if measured)
- l) Quality and type of screws and nuts employed
- m) Length of thread engagement (where applicable)

7.15.4 Measured Values

- a) Parameters of load application e.g., rate of increase of load, size of load increase steps, etc.
- b) Displacements measured as a function of the applied load
- c) Any special observations concerning application of the load
- d) Width of crack during the loading of the anchor (where applicable)
- e) Failure load & cause(s) of rupture or failure
- f) Radius (maximum radius, minimum radius) and height of a concrete cone produced in the test (where applicable)
- g) Particulars of tests with crack cycles
 - 1) Constant load on anchor and method of applying it
 - 2) Frequency of crack openings
 - 3) Anchor displacements and crack width Δw_1 , Δw_2 as a function of the number of crack openings
- h) Particulars of repeated load tests
 - 1) Minimum and maximum load
 - 2) Frequency & number of cycles
 - 3) Displacements as function of the number of cycles
- i) Particulars of test for determining the minimum spacing and edge distance
 - 1) Increment of torque
 - 2) Number of revolutions
 - 3) Torque moment at the forming of a hairline crack at each anchor
 - 4) Maximum torque moment applied to each anchor
- j) Particulars of torque test
 - 1) Increment of torque
 - 2) Tension force as a function of the applied torque moment

7.15.5 Particulars of Identification

- a) Dimensions of the parts of the anchor and the drilling and installation tools
- b) Properties for example, tensile strength, elastic limit, elongation at rupture, hardness and surface conditions of anchor cone and sleeve, if applicable

The above measurements in **7.15.1** to **7.15.4** shall be recorded for each test.

8 ASSESSMENT CRITERIA AND METHOD

8.1 General Procedure

The assessment method defined in this standard shall be used to assess mechanical strength and stability of post-installed mechanical anchors. The assessment method given in this standard shall be applicable only to the following:

8.1.1 Anchors of diameter greater than or equal to 6 mm

8.1.2 Anchors with embedment depth greater than or equal to 40 mm.

NOTE – For anchoring components which are statically indeterminate (such as light weight suspended ceilings) and subject to internal exposure conditions, this minimum embedment requirement may be reduced to 30 mm.

8.1.3 Base material of thickness greater than $2h_{ef}$ but not less than 120 mm, unless specified otherwise.

8.1.4 Exposure to temperature range of -40°C to $+80^{\circ}\text{C}$ during service life.

8.1.5 Anchors for use in “uncracked” concrete only or “cracked and uncracked” concrete.

8.1.6 Anchors subjected to static, quasi static or seismic conditions.

8.1.7 Anchors with estimated service life of 50 years.

Commentary– The actual service life of a product is dependent on the specific exposure condition, intended use, quality of installation, maintenance etc. This requirement on the service life is only a means of defining appropriate assessment procedure. It should not be interpreted as a guarantee given by the manufacturer or the approval body but regarded only as a means for expressing the expected economically reasonable service life of the anchor. The assessment provisions in this standard are based on available knowledge and experience.

8.1.8 General Assessment Method given in Annex D shall apply.

8.1.9 The results of assessment shall be reported in AR for design according to CED 02(25733). Sample format for AR is given in Annex E.

8.2 Method for Assessing Characteristic Resistance to Tension

8.2.1 Resistance to Steel Failure

It shall be established by assessing results of Steel Capacity Test (Test Series 1) and Torque test (Test series 2).

- a) Determination of characteristic steel strength – The characteristic resistance to steel failure shall be calculated using the following equation. The smallest area of cross-section in area of load transfer shall apply.

$$N_{Rk,s} = A_s f_u$$

- 1) If the steel strength varies along the length of anchor then the steel capacity shall be calculated using the above equation for all such sections and the minimum value shall govern.
- 2) If it is not possible to establish distribution of steel strength along the length of the anchor then steel capacity test shall be performed in accordance with Steel Capacity Test (Test Series 1) to determine the characteristic resistance. The modulus of elasticity may be taken as per structural properties of material of the anchor.
- 3) The 5th percentile determined from the tests shall be normalized as per Annex D to specified steel strength to account for over strength. In this case, the normalized 5th percentile value shall be taken as the characteristic value.

- b) Verification of installation torque – The mean value of the tension force and 95th percentile of the tension force at $1.3T_{inst}$ shall be determined after completion of the test. It shall be established that the installation torque recommended by manufacturer will not result in steel failure of bolt during application. To establish this parameter tests shall be performed in accordance with “Maximum Torque Moment Test” (Test Series 2). The following criteria shall be fulfilled: -
- 1) The 95th percentile of the tension force generated in torque tests at a torque moment T equal to $1.3T_{inst}$ shall be smaller than the nominal yield force of the bolt or screw.
 - 2) The tension force generated in the torque test shall be less than the concrete cone capacity determined according to CED 02(25733).
 - 3) The connection should be capable of being un-torqued (or unscrewed) after completion of the test.
 - 4) For torque-controlled expansion anchors, in addition, no turning of anchor shall occur up to a torque of $1.3T_{inst}$ for bolt type anchors.
 - 5) For displacement-controlled anchors, in addition, it shall be shown that the longest permissible threaded bolt does not come in contact with the cone when a torque of $1.3T_{inst}$ is applied.
- c) Verification of hydrogen embrittlement of concrete screws – During the constant load portion of the Test Series 3 (100 hrs.), no anchor shall fail. If concrete failure occurs then the tests shall be repeated. For the residual load test, the mean ultimate and 5th percentile determined from the tests shall be normalized as per **Annex D** accounting for relevant failure mode (in this case steel failure). The reduction factor α shall be determined according to **D-5** using corresponding reference Test Series 5. If steel failure occurs during the constant load portion of the test or if calculated reduction factor α for residual load test is not greater than or equal to 0.9, the product is deemed not to meet the requirements of this test.

8.2.2 Resistance to Pull-out Failure

The tests are performed to determine the tension capacity of a single anchor without edge influence. The following assessment criteria shall apply to these tests.

- a) Assessment of ultimate failure load
- 1) The assessment shall be made for all anchor size and for each embedment depth.
 - 2) The mean ultimate failure load and the 5th percentile value (see **D-2**) of all test series shall be converted to nominal concrete strength as per **D-1** depending on failure type. The normalized values shall be used for calculating reduction factors.
NOTE – If mixed failure types occur in a test series then the normalization shall be performed assuming the failure type which was observed in majority of tests in that test series.
 - 3) The coefficient of variation of the test series shall be determined; It shall be less than 15 percent for reference test and 20 percent for other tests. If the coefficient of variation is higher than the limit defined for corresponding test series then the reduction factor β_{vF} shall be calculated according to **D-4**.

- 4) The reduction factor α for the test series (except for reference tests) shall be calculated according to **D-5** using corresponding reference test as mentioned in Table 2 for each test series.
 - 5) The ratio α/α_{reqd} shall be then determined using the calculated α factor and the α_{reqd} factor recommended in Table 2 for each test series. If all anchor diameters have not been tested then the smallest reduction factor α shall apply for other diameters as well for that test series.
 - 6) If the requirements on uncontrolled slip are not fulfilled, then the reduction factor α_1 and the ratio $\alpha_1/\alpha_{1,reqd}$ shall be calculated according to **D-6**.
- b) Assessment of load-displacement behavior – The load-displacement curves shall be examined for indication of uncontrolled slip according to **D-6**. The displacement at 50 percent of the mean ultimate failure load (for each test of test series) along with its corresponding coefficient of variation of displacement shall be determined. If the displacements at 50 percent of the mean ultimate failure load are larger than 0.4 mm then the coefficient of variation of displacement corresponding to displacement at 50 percent of the mean ultimate failure load shall not exceed 25 percent for reference tension tests and 40 percent for other tests (see **D-7**).
- 1) In addition for Test Series 10, the rate of increase of anchor displacement in crack cycling tests shall either decrease or be almost constant when plotted in a half-logarithmic scale (see Fig 20). The criteria of the allowable displacement δ_{20} after 20 cycles and δ_{1000} after 1000 cycles of crack opening shall be graduated as a function of the number of tests as per Table 6. If these requirements w.r.t to stabilization of displacement and allowable displacement are not met then the crack cycle test shall be repeated with reduced tension load on the anchor. In this case, a reduction factor α_p shall be calculated as a ratio of the reduced to the actual sustained load N_{sus} applied on the anchor during crack cycles.

NOTE – The displacements may be considered to be stabilized if the increase of displacements during cycle no. 750 to 1000 is smaller than the displacement recorded during cycle no. 500 to 750.

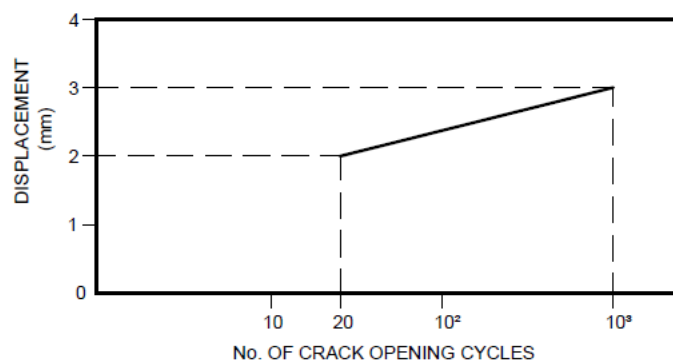

FIG. 20 CRITERIA FOR RESULTS OF TESTS WITH INDUCED CRACKS

**Table 6 Limit for Allowable Displacement for Crack Cycling Test
(as per Option B)**
[Clause 8.2.2(b)]

Number of tests	Limits for allowable displacement depending on no. of samples tested
5 to 9	$\bar{\delta}_{20} \leq 2 \text{ mm}$ $\bar{\delta}_{1000} \leq 3 \text{ mm}$
10 to 20	$\bar{\delta}_{20} \leq 2 \text{ mm}$; one test is allowed up to 3 mm $\bar{\delta}_{1000} \leq 3 \text{ mm}$; one test is allowed to up to 4 mm
> 20 tests	$\bar{\delta}_{20} \leq 2 \text{ mm}$; 5% of tests are allowed to 3 mm $\bar{\delta}_{1000} \leq 3 \text{ mm}$; 5% of tests are allowed to 4 mm

- 2) In addition for Test Series 11, the increase in anchor displacements when subjected to repeated load cycle shall stabilize during cycling in a manner such that application of some additional cycles shall not cause failure. No failure shall occur during the repeated load cycles. If these requirements are not met then the load for repeated cycles shall be calculated with reduced characteristic strength and the tests shall be repeated until these requirements are met. In this case, a reduction factor α_p shall be calculated as a ratio of the reduced characteristic strength to the actual characteristic strength used for calculating the load for repeated load cycles (60% of the characteristic strength in uncracked concrete).
- c) Determination of characteristic pullout strength – The basic characteristic strength ($N_{Rk,0}$) in tension in uncracked concrete shall be taken as the characteristic load value obtained from reference tension tests in low and high strength uncracked concrete (Test Series 4 and 5). The minimum of the two values shall govern after normalization to M25. Normalization shall be done as per **D-1**. Similarly, the $N_{Rk,0}$ value for cracked concrete shall be determined from Test Series 6 and 7. Minimum value of β_{vF} , α/α_{reqd} , $\alpha/\alpha_{1,reqd}$ and α_p factor obtained from Test series 4 to 12 as per **8.2.2(a)** shall be used in the following equation to determine $N_{Rk,p}$. If the calculated $N_{Rk,p}$ is greater than $N_{Rk,c}^0$ then it shall be stated in the AR that pullout is not decisive.

$$N_{Rk,p} = N_{Rk,0} \cdot \min\{(\alpha_p); \min(\alpha_1/\alpha_{1,reqd}); \min(\alpha/\alpha_{reqd})\} \cdot \min(\beta_{vF}) \leq N_{Rk,c}^0$$

where

$$N_{Rk,c}^0 = \begin{cases} 7.2\sqrt{f_{ck}}h_{ef}^{1.5} & \text{For cracked concrete} \\ 10.1\sqrt{f_{ck}}h_{ef}^{1.5} & \text{For uncracked concrete} \end{cases}$$

8.2.3 Concrete Cone Strength

The concrete cone strength shall be calculated according to CED 02(25733).

NOTE – No additional test and assessment is required to establish concrete cone strength when the design method given in CED 02(25733) is used. However, if the AR provides a higher performance for concrete cone failure, the same may be adopted for design purpose.

8.2.4 Partial Safety Factor for Installation

It shall be determined from tests for robustness of anchors to variation in use condition (Test Series 16) and robustness of anchors in contact with reinforcement (Test Series 19). The ultimate load for each test series shall be assessed as per 8.2.2(a)(2) to (4) and the load displacement behavior shall be assessed as per 8.2.2(b). The calculated α factor shall be used to determine installation safety factor according to Table 7 for each test series. For example, if the calculated α for Test Series 16 is 0.75 then the γ_{inst} factor for that test series shall be taken as 1.4. The minimum value of installation safety factor determined from the two test series shall govern.

Table 7 Values of Req. α in the Installation Safety Tests
(Clause 8.2.4)

Installation safety factor γ_{inst}	Req. α for Test Series 16	Req. α for Test Series 19
1.0	≥ 0.95	≥ 0.85
1.2	$0.95 > \alpha \geq 0.8$	$0.85 > \alpha \geq 0.7$
1.4	$0.8 > \alpha \geq 0.7$	$0.7 > \alpha \geq 0.6$

8.2.5 Minimum Edge and Spacing

Permissible minimum edge and spacing shall be determined by assessing results of Test Series 17 on double anchor group. The characteristic torque moment, T_{Rk} , shall be determined from the test results according to **D-2**.

- a) Displacement-controlled expansion anchors – If the minimum edge and spacing value recommended by manufacturer fulfill the test, then the required splitting area shall be given by

For use in cracked concrete: Required $A_{sp} = 1.3A_{sp,t}$

For use in uncracked concrete: Required $A_{sp} = 1.7A_{sp,t}$

where

$$A_{sp,t} = (3c'_{min} + s'_{min})(1.5c'_{min} + h_{ef}) \text{ if } D > (1.5c' + h_{ef})$$

$$A_{sp,t} = (3c'_{min} + s'_{min}) \cdot D \text{ if } D \leq (1.5c' + h_{ef})$$

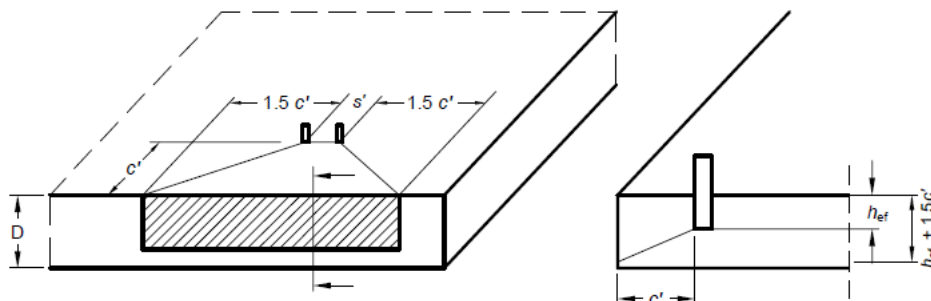

FIG. 21 PROJECTING AREA $A_{sp,t}$

- b) Torque-controlled expansion and undercut anchors – The characteristic torque moment determined from test shall fulfill the following equation in case of concrete failure.

Commentary - The partial safety factor k_1 is based on whether or not the scatter of the friction coefficients (between nut and washer), which determine the magnitude of the splitting forces at the required torque (req. T_{inst}) is controlled during production to the values corresponding to the anchors used in the approval tests. The choice between the two shall be indicated in the Factory Production Control program.

NOTE – If steel failure occurs, this check is not required as increase in edge distance and spacing will not affect the failure type. The tested edge distance and spacing shall be accepted.

$$T_{Rk} \geq k_1 req. T_{inst} \cdot \left(\frac{f_{c,t}}{f_{ck}} \right)^{0.5}$$

Table 8 Values of k_1
[Clause 8.2.5(b)]

Scatter of the friction coefficients (between nut and washer)	k_1	
	Anchors in uncracked concrete	Anchors in cracked concrete
Controlled during production	1.7	1.3
Not controlled during production	2.1	1.5

8.2.6 Robustness of Concrete Screws Against Torquing in Standard and High Strength Concrete

The 5th percentile of the ultimate torque of the test series shall be determined. To ensure the performance of concrete screws in standard and high strength uncracked concrete, the characteristic torque moment determined from test shall fulfill the following equations

For tests with steel failure,

$$T_{u,5\%} = 1.5 T_{inst.} \left(\frac{f_{u,t}}{f_{uk}} \right) / \beta_{vF}$$

For tests with concrete failure,

$$T_{u,5\%} = 2.1 T_{inst.} \left(\frac{f_{c,t}}{f_{ck}} \right)^{0.5} / \beta_{vF}$$

8.2.7 Performance of Concrete Screws for Setting with Impact Screw Driver

No failure shall occur during the test. If one failure is observed, the Evaluation Agency may double the sample space, restricting to one failure. In case any more failures are observed, the anchor cannot be declared suitable for use with impact screw driver.

8.2.8 Edge Distance to Avoid Splitting when Subjected to Load

The critical splitting edge distance ($c'_{cr,sp}$) shall be determined from Test Series 18. The critical spacing ($s'_{cr,sp}$) shall be taken as twice the critical splitting edge distance. The mean ultimate

load, 5th percentile of load and coefficient of variation shall be determined. The mean ultimate failure load of anchors at the corner shall be statistically equivalent as that of reference tension Test Series 4 when normalized for the same concrete strength. If this condition is not fulfilled, then the tests shall be repeated with larger edge distance. The characteristics splitting strength shall be determined by normalizing the 5th percentile of ultimate load, accounting for relevant failure mode.

NOTE - If the critical splitting edge distance is found to be smaller than or equal to $c'_{cr,N}$, then the calculation of the splitting strength may be neglected in the design of anchorages. This should be explicitly mentioned in AR.

8.2.9 Displacement under Static and Quasi-Static Loading

- a) The displacements under short term tension (δ_{N0}) shall be evaluated from the reference tension tests on single anchors (Test Series 4 to 7), depending on assessment option selected. The maximum displacement value corresponding to load F calculated according to the following equation, shall be noted for each test series. The maximum displacement value obtained in the test series shall govern.

$$F = \frac{F_{Rk}}{1.4\gamma_M}$$

where

F_{Rk} = Characteristic strength evaluated based on all tests for a given load direction (Tension or shear)
 γ_M = Material partial safety factor according to CED 2(0097)WD for the corresponding failure mode

- b) *Displacements under long term tension*

- 1) For assessment according to Option B, the displacements under long term tension loading ($\delta_{N\infty}$), shall be evaluated from crack cycling tests (Test Series 10) using the following equation.

$$\delta_{N\infty} = \delta_{m1} / 1.5$$

where

δ_{m1} = Average anchor displacement after 1000 crack cycles.

- 2) For assessment according to Option C, the displacements under long term tension loading ($\delta_{N\infty}$) shall be evaluated from repeated load tests (Test Series 11) using the following equation.

$$\delta_{N\infty} = \delta_{m2} / 2.0$$

where

δ_{m2} = Average displacement in the repeated load tests at the end of 10^5 load cycles.

8.3 Method for Assessing Strength of Anchor in Shear

8.3.1 Determination of Characteristic Strength of Single Anchor in Case of Steel Failure

Steel strength of anchors with uniform strength along length of anchor shall be calculated according to CED 02(25733) and provided in AR. Steel strength of anchors with non-uniform strength or significantly reduced cross section along length of anchor shall be evaluated based

on results of shear Test Series 20. The mean ultimate load, 5th percentile of load and coefficient of variation shall be determined. $V_{Rk,s}^0$ shall be taken as 5th percentile of ultimate load after normalization. The characteristic load determined from shear test shall be used. The characteristic resistance of a group of anchors in case of steel failure is influenced by the ductility of the anchor. The influence factor k_1 [7.2.3.1 of CED 02(25733)] may be taken from the AR of the anchor based on manufacturer recommendation. The commonly acceptable value is 1.0 for rupture elongation > 8 percent and 0.8 for rupture elongation ≤ 8 percent.

8.3.2 Concrete Pry-out Strength

The mean ultimate load, 5th percentile of load and coefficient of variation shall be determined. The assessment shall be carried using results of Test Series 21. The value of k_{cp} shall be obtained from the respective AR.

8.3.3 Concrete Edge Strength

The concrete edge strength shall be calculated according to CED 02(25733). The effective length of anchor for transfer of shear shall be provided by the manufacturer in the AR.

Commentary - No additional test and assessment shall be required to establish concrete edge strength when the design method given in CED 02(25733) is used.

8.3.4 Displacement under Static and Quasi-Static Loading

- a) Displacements under short term shear loading (δ_{v0}) shall be evaluated from the shear tests on single anchors (Test Series 20). The displacement value corresponding to load F calculated according to the equation in **8.2.9 (a)** shall be noted for each test series. The maximum displacement value obtained shall govern.

NOTE - It should be sufficient to give one value each for the short term tension and short term shear displacement. This value should represent the most unfavorable condition and should be valid for all concrete strength classes and state of concrete (cracked/uncracked).

- b) Displacements under long term shear loading ($\delta_{v\infty}$) shall be assumed to be equal to 1.5 times the displacements under short term shear loading (δ_{v0}).

NOTE – The load at which the first slip occurs cannot be ensured in long term because of the influence of shrinkage and creep of the concrete, crack formation etc.

8.4 Method for Assessing Characteristic Strength When Subjected to Seismic Conditions

8.4.1 The reduction factor shall be calculated as per **D-4** and this section. The load-displacement scatter requirement shall be as per **D-6** and this section. In case of conflict, the requirement of this section shall be applicable. In case the load-displacement behavior requirements are not met, it shall be permitted to increase the no. of tests to meet the requirements.

8.4.2 Assessment of Test Series S1 and S2

The mean ultimate load and 5th percentile of ultimate load shall be determined. The coefficient of variation shall also be determined.

- a) Assessment of ultimate failure load of Test Series S1 and S2 – The reduction factor for each test series shall be determined as follows. Prior to comparison of results of both test series, the load values shall be normalized to 25 MPa concrete strength, depending on the failure type observed in the test series.

Reduction factor for Test Series S1:

$$\alpha_{ts_S1} = \begin{cases} 1 & \text{if } N_{u,m,ts_S1} \geq 0.8N_{u,m,cr',ts8} \\ N_{u,m,ts_S1}/0.8N_{u,m,cr',ts8} & \text{if } N_{u,m,ts_S1} < 0.8N_{u,m,cr',ts8} \end{cases}$$

Reduction factor for Test Series S2:

$$\alpha_{ts_S2} = \begin{cases} 1 & \text{if } N_{u,m,ts_S2} \geq 0.8N_{u,m,cr',ts9} \\ N_{u,m,ts_S2}/0.8N_{u,m,cr',ts9} & \text{if } N_{u,m,ts_S2} < 0.8N_{u,m,cr',ts9} \end{cases}$$

- b) The scatter of ultimate failure load of Test Series S1 and S2 shall be assessed as per **8.2.2(a)(3)**. The minimum of the two β_{vF} values shall govern. If the coefficient of variation is higher than 30 percent then the anchor shall be deemed unsuitable for use in seismic situation. It shall be permitted to increase no. of tests in the test series to fulfill the limit for coefficient of variation.
- c) The load-displacement behavior of Test Series S1 and S2 shall be assessed as per **8.2.2(b)**. If this condition is not met then the anchors shall be deemed unsuitable for use in seismic conditions.

NOTE – This requirement is not applicable if this displacement (that is, at 50 percent of the mean ultimate failure load) is less than or equal to 0.4 mm.

- d) The final reduction factor of Test Series S1 and S2 shall be calculated as follows.

$$\alpha_{ts_S1,S2} = \min(\alpha_{ts_S1}; \alpha_{ts_S2})$$

8.4.3 Assessment of Test Series S3

The mean ultimate load and 5th percentile of ultimate load shall be determined. The coefficient of variation shall also be determined.

- a) Assessment of ultimate failure load of Test Series S3 – The reduction factor shall be determined as follows. Prior to comparison of results of both test series, the load values shall be normalized to 25 MPa concrete strength, depending on the failure type observed in the test series. If pull-out or pull-through failure occurs in this test series, the anchor shall be deemed unsuitable for use in seismic conditions. It shall be permitted to test with larger embedment to avoid pull-out or pull-through failure.

$$\alpha_{ts_S3} = \begin{cases} 1 & \text{if } V_{u,m,ts_S3} \geq 0.8V_{u,m,uncr',ts20} \\ V_{u,m,ts_S3}/0.8V_{u,m,uncr',ts20} & \text{if } V_{u,m,ts_S3} < 0.8V_{u,m,uncr',ts20} \end{cases}$$

- b) The scatter of ultimate failure load of Test Series S3 shall be assessed as per **8.2.2(a)(3)**. If the coefficient of variation is higher than 30 percent then the anchor shall be deemed unsuitable for use in seismic situation.

8.4.4 Assessment of Test Series S4

The mean ultimate load and 5th percentile of ultimate load shall be determined. The coefficient of variation shall also be determined.

a) Assessment of pulsating tension load cycle

- 1) If the anchor fails to develop required resistance in any of the tension load cycles prior to completion of all cycles, then the test shall be recorded as unsuccessful and the test shall be repeated with reduced N_{max} ($N_{max, reduced}$), that is, maximum load of tension load cycle, until the anchor successfully completes the load cycle. In this case, the reduction factor $\alpha_{ts, S4}$ shall be calculated as follows.

$$\alpha_{ts, S4} = (N_{max, reduced}) / N_{max}$$

- 2) The anchor displacements shall be assessed for the last load cycle corresponding to load value $0.5 N / N_{max}$ and $1.0 N / N_{max}$. If the N_{max} is reduced then the revised value of N_{max} (i.e., $N_{max, reduced}$) shall be used to determine the corresponding load value at which displacements shall be assessed. Mean of the displacements measured at both load values shall be recorded after the anchor successfully completes the load cycle. The mean displacement corresponding to $0.5 N / N_{max}$ or $0.5 N / (N_{max, reduced})$ shall be less than 7 mm. If this displacement limit is not met then the tests shall be repeated with further reduced "maximum load of tension cycle" and $\alpha_{ts, S4}$ shall be recalculated with this reduced load value. Minimum of the $\alpha_{ts, S4}$ value calculated as per 8.4.4(a)(1) and (2) shall be used.

b) Assessment of residual load test of Test Series S4

- 1) Assessment of ultimate failure load of Test Series S4 – The reduction factor shall be determined as follows. Prior to comparison of results of both test series, the load values shall be normalized to 25 MPa concrete strength, depending on the failure type observed in the test series. Alternatively, the results of Test Series S1 may be normalized to that of S4.

$$\alpha_{ts, S4} = \begin{cases} 1 & \text{if } N_{u, m, ts, S4} \geq 0.9 N_{u, m, ts, S1} \\ N_{u, m, ts, S4} / 0.9 N_{u, m, ts, S1} & \text{if } N_{u, m, ts, S4} < 0.9 N_{u, m, ts, S1} \end{cases}$$

Note – Instead of calculating, it may also be permitted to repeat pulsating tension load cycle with further reduced value of N_{max} to fulfill the above requirement.

- 2) The scatter of ultimate failure load of Test Series S4 shall be assessed as per 8.2.2(a)(3). If the coefficient of variation is higher than 30% then the anchor shall be deemed unsuitable for use in seismic situation.
- 3) The load-displacement behavior of Test Series S4 shall be assessed as per 8.2.2(b). If this condition is not met then the anchors shall be deemed unsuitable for use in seismic conditions.

NOTE – This requirement is not applicable if this displacement (that is, at 50 percent of the mean ultimate failure load) is less than or equal to 0.4 mm.

- 4) The final reduction factor of Test Series S4 shall be calculated as follows.

$$\alpha_{ts_S4} = \alpha_{ts_S4'} * \alpha_{ts_S4''}$$

8.4.5 Assessment of Test Series S5

The mean ultimate load and 5th percentile of ultimate load shall be determined. The coefficient of variation shall also be determined.

a) Assessment of alternating shear test

- 1) If the anchor fails to develop required resistance in any of the shear load cycles prior to completion of all cycles, then the test shall be recorded as unsuccessful and the test shall be repeated with reduced V_{max} ($V_{max, reduced}$), i.e., maximum load of shear load cycle, until the anchor successfully completes the load cycle. In this case, the reduction factor $\alpha_{ts_S5'}$ shall be calculated as follows.

$$\alpha_{ts_S5'} = (V_{max, reduced})/V_{max}$$

- 2) The anchor displacements shall be assessed for the last load cycle corresponding to load value $\pm 0.5 V/V_{max}$ and $\pm 1.0 V/V_{max}$. If the V_{max} is reduced then the revised value of V_{max} (i.e., $V_{max, reduced}$) shall be used to determine the corresponding load value at which displacements shall be assessed. After the anchor successfully completes the load cycle, displacements measured at both load values shall be recorded as the maximum of mean of absolute displacement values in positive and in negative load direction for each load value (i.e. $\pm 0.5 V/V_{max}$ and $\pm 1.0 V/V_{max}$). The mean displacement corresponding to $\pm 0.5 V/V_{max}$ or $\pm 0.5 V/(V_{max, reduced})$ shall be less than 7 mm. If this displacement limit is not met then the tests shall be repeated with further reduced "maximum load of shear cycle" and $\alpha_{ts_S5'}$ shall be recalculated with this reduced load value. Minimum of the $\alpha_{ts_S5'}$ value calculated as per 8.4.5(a)(1) and (2) shall be used.

b) Assessment of residual load test of Test Series S5

- 1) Assessment of ultimate failure load of Test Series S5 – The reduction factor shall be determined as follows. Prior to comparison of results of both test series, the load values shall be normalized to 25 MPa concrete strength, depending on the failure type observed in the test series. Alternatively, the results of Test Series S3 may be normalized to that of S5. If pull-out or pull-through failure occurs in this test series, the anchor shall be deemed unsuitable for use in seismic conditions. It shall be permitted to test with larger embedment to avoid pull-out or pull-through failure.

$$\alpha_{ts_S5''} = \begin{cases} 1 & \text{if } V_{u,m,ts_S5} \geq 0.95V_{u,m,ts_S3} \\ V_{u,m,ts_S5}/0.95V_{u,m,ts_S3} & \text{if } V_{u,m,ts_S5} < 0.95V_{u,m,ts_S3} \end{cases}$$

NOTE – Instead of calculating, it may also be permitted to repeat alternating shear load cycle with further reduced value of V_{max} to fulfill the above requirement.

- 2) The load-displacement behavior of Test Series S4 shall be assessed as per 8.2.2(b). If this condition is not met then the anchors shall be deemed unsuitable for use in seismic conditions.

- 3) The final reduction factor of Test Series S5 shall be calculated as follows.

$$\alpha_{ts_S5} = \alpha_{ts_S5'} * \alpha_{ts_S5''}$$

8.4.6 Assessment of Test Series S6

The mean ultimate load and 5th percentile of ultimate load shall be determined. The coefficient of variation shall also be determined.

- a) Assessment of pulsating tension load cycle

- 1) If the anchor fails to develop required resistance in any of the cycles prior to completion of all crack cycles, then the test shall be recorded as unsuccessful and the test shall be repeated with proportionally reduced values of N_{w1} ($N_{w1, reduced}$) and N_{w2} ($N_{w2, reduced}$), that is, maximum sustained load the anchor is subjected to during crack cycle, until the anchor successfully completes the crack cycle. In this case, the reduction factor $\alpha_{ts_S6'}$ shall be calculated as follows.

$$\alpha_{ts_S6'} = (N_{w2, reduced})/N_{w2}$$

- 2) The anchor displacements shall be assessed for the last load cycle corresponding to crack width $\Delta w = 0.5 \text{ mm}$ and $\Delta w = 0.8 \text{ mm}$. Mean of the displacements measured at both crack widths shall be recorded after the anchor successfully completes the crack cycle. The mean displacement corresponding to $\Delta w = 0.5 \text{ mm}$ shall be less than 7 mm. If this displacement limit is not met then the tests shall be repeated with further reduced value of N_{w1} & N_{w2} and $\alpha_{ts_S6'}$ shall be recalculated with this reduced load value. Minimum of the $\alpha_{ts_S6'}$ value calculated as per 8.4.6(a)(1) and (2) shall be used.

- b) Assessment of residual load test of Test Series S6

- 1) Assessment of ultimate failure load of Test Series S6 – The reduction factor shall be determined as follows. Prior to comparison of results of both test series, the load values shall be normalized to 25 MPa concrete strength, depending on the failure type observed in the test series. Alternatively, the results of Test Series S1 may be normalized to that of S6.

$$\alpha_{ts_S6''} = \begin{cases} 1 & \text{if } N_{u,m,ts_S6} \geq 0.9N_{u,m,ts_S1} \\ N_{u,m,ts_S6}/0.9N_{u,m,ts_S1} & \text{if } N_{u,m,ts_S6} < 0.9N_{u,m,ts_S1} \end{cases}$$

NOTE – Instead of calculating, it may also be permitted to repeat crack cycle with further reduced value of N_{w1} & N_{w2} to fulfill the above requirement.

- 2) The scatter of ultimate failure load of Test Series S6 shall be assessed as per 8.2.2(a)(3). If the coefficient of variation is higher than 30 percent then the anchor shall be deemed unsuitable for use in seismic situation.
- 3) The load-displacement behavior of Test Series S6 shall be assessed as per 8.2.2(b). If this condition is not met then the anchors shall be deemed unsuitable for use in seismic conditions.

NOTE – This requirement is not applicable if this displacement (that is, at 50 percent of the mean ultimate failure load) is less than or equal to 0.4 mm.

- 4) The final reduction factor of Test Series S6 shall be calculated as follows.

$$\alpha_{ts_S6} = \alpha_{ts_S6'} * \alpha_{ts_S6''}$$

8.4.7 Determination of Governing Reduction Factors

- a) The governing reduction factors for tension for seismic shall be determined as follows

$$\alpha_N = \min(\alpha_{ts_{S4}}; \alpha_{ts_{S6}}) \cdot \alpha_{ts_S1,S2}$$

$$\beta_{vF,N} = \min(\beta_{ts_{S4}}; \beta_{ts_{S6}}) \cdot \beta_{ts_S1,S2}$$

The calculated reduction factor shall be applicable to the embedment depth that has been tested as well as to shorter embedment depths than the one tested.

NOTE – If multiple embedment depths have been tested for an anchor diameter and different failure type were observed in these tests then it shall be permitted to calculate different reduction factor for steel and pull-out failure.

- b) The governing reduction factors for shear for seismic shall be determined as follows

$$\alpha_V = \alpha_{ts_S3} * \alpha_{ts_S5}$$

$$\beta_{vF,V} = \min(\beta_{ts_S3}; \beta_{ts_S5})$$

The calculated reduction factor shall be applicable to the embedment depth that has been tested as well as longer embedment depths than the one tested.

NOTE – If multiple embedment depths have been tested for an anchor diameter then the reduction factors for intermediate depths may be determined by linear interpolation.

8.4.8 Determination of Characteristic Strength under Seismic Conditions

- a) The characteristic steel strength in tension under seismic conditions, $N_{Rk,s,seis}$, shall be determined as follows.

$$N_{Rk,s,seis} = \alpha_N \beta_{vF,N} N_{Rk,s}$$

where

$N_{Rk,s}$ = Characteristic steel strength determined for static conditions as per **8.2.1**.

- b) The characteristic pull-out strength in tension under seismic conditions, $N_{Rk,p,seis}$, shall be determined as follows.

$$N_{Rk,p,seis} = \alpha_N \beta_{vF,N} N_{Rk,0}$$

where

$N_{Rk,0}$ = Characteristic strength determined from Test series 8 and 9 after normalization of test loads to 25 MPa concrete strength.

NOTE

Characteristic strength may be determined from Test Series 8 and 9 by using any of the following methods:

- a) Minimum of characteristic strength value of Test Series 8 and 9
- b) Characteristic strength determined from combined test data of Test Series 8 and 9
- c) Maximum of (a) and (b)

The calculated $N_{Rk,p,seis}$ shall be applicable to the embedment depth that has been tested as well as to shorter embedment depths than the one tested.

- c) The characteristic steel strength in shear under seismic conditions, $V_{Rk,s,seis}$, shall be determined as follows. Only steel failure type is considered in seismic evaluation for shear.

$$V_{Rk,s,seis} = \alpha_V \beta_{vF,V} V_{Rk,s}^0$$

where

$V_{Rk,s}^0$ = Characteristic steel strength determined for static conditions as per **8.3.1**

The calculated $V_{Rk,s,seis}$ shall be applicable to the embedment depth that has been tested as well as to longer embedment depths than the one tested. If multiple embedment depths have been tested for an anchor diameter then the characteristic resistance for intermediate depths may be determined by linear interpolation.

- d) The anchor displacement at damage limit state and ultimate limit state for seismic conditions shall be determined as per Table 9.

Table 9 Displacements to be Reported in AR

[Clause 8.4.7(d)]

Displacement ¹	Determination process ²
$\delta_{N,seis}(DLS)$	Maximum of mean value of displacements at $0.5 N/N_{max}$ as per (Test Series S4 and at $\Delta w = 0.5 \text{ mm}$ (as per Test Series S6)
$\delta_{N,seis}(ULS)$	Maximum of mean value of displacements at $1.0 N/N_{max}$ as per (Test Series S4 and at $\Delta w = 0.8 \text{ mm}$ (as per Test Series S6)
$\delta_{V,seis}(DLS)$	Mean value of displacement at $0.5 V/V_{max}$ (as per Test Series S5)
$\delta_{V,seis}(ULS)$	Mean value of displacement at $1.0 V/V_{max}$ (as per Test Series S5)

NOTES

¹ DLS is Damage limit state and ULS is Ultimate limit state.

² If N_{max} or V_{max} had to be reduced in the test series then the ratio $N/(N_{max, reduced})$ or $V/(V_{max, reduced})$ shall be used (as applicable).

- e) The partial safety factor for seismic design shall be taken as same as static.
- f) The reduction factor to account for effect of annular gap in shear shall be taken as 0.5 for anchors with hole clearance as per this standard or equal to 1 if the MPII requires gap to be filled (provided the shear tests have been carried out accordingly).

NOTE – If annular gap is present between the anchor and fixture then the force on anchor is amplified in shear due to hammer effect on anchor.

TABLE 2 Summary of Tests for Evaluating Performance of Post-Installed Mechanical Anchors
 [Clause 6.5.3, 7.1.1 and 8.2.2(a)]

Test Series No.	Title	Concrete strength	Crack width Δw [mm]	Anchor diameters to be tested ⁽¹⁾	Drill bit cutting diameter range (d_{cut})	Min. No. of samples to be tested for each anchor size	Other deviations from standard Installation and test conditions, if any	Measurement and Assessment checks (TS – Test Series) ⁶	Test Reference section	Test applicable to ⁽²⁾	Assessment option
(1)	(2)	(3)	(4)	(5)	(6)	(7)	(8)	(9)	(10)	(11)	(12)
1	Steel capacity test in tension	High	0	All	$d_{cut,m}$	5		Assessment as per 8.2.1(a)	7.2	TC, DC, UC, CS	B, C
2	Maximum installation torque moment test	High	0	All	$d_{cut,m}$	5		Determine $N_{u,m}$ and $N_{u,95\%}@ 1.3T_{inst}$ Assessment as per 8.2.1(b)	7.3	TC, DC, UC	B,C
3	Hydrogen induced embrittlement	High	0	All	$d_{cut,m}$	5		Assessment as per 8.2.1(c)	7.4	CS	B,C
4	Reference tension test	Standard	0	All	$d_{cut,m}$	5		Determine $N_{u,m}$, $N_{u,5\%}$ and v_F Check $v_F \leq 15\%$ Determine β_{vF} ⁽⁵⁾ Assessment as per 8.2.2 and 8.2.9(a)	7.5	TC, DC, UC, CS	B,C
5	Reference tension test ⁽³⁾	High	0	All	$d_{cut,m}$	5		Determine $N_{u,m}$, $N_{u,5\%}$ and v_F Check $v_F \leq 15\%$ Determine β_{vF} ⁽⁵⁾ Assessment as per 8.2.2 and 8.2.9(a)	7.5	TC, DC, UC, CS	B,C
6	Reference tension test	Standard	0.3	All	$d_{cut,m}$	5		Determine $N_{u,m}$, $N_{u,5\%}$ and v_F Check $v_F \leq 15\%$ Determine β_{vF} ⁽⁵⁾ Assessment as per 8.2.2 and 8.2.9(a)	7.5	TC, DC, UC, CS	B
7	Reference tension test ⁽³⁾	High	0.3	All	$d_{cut,m}$	5		Determine $N_{u,m}$, $N_{u,5\%}$ and v_F Check $v_F \leq 15\%$ Determine β_{vF} ⁽⁵⁾ Assessment as per 8.2.2 and 8.2.9(a)	7.5	TC, DC, UC, CS	B
8	Maximum crack width & large hole diameter ⁽⁴⁾	Standard	0	S/M/L	$d_{cut,max}$	5		Determine $N_{u,m}$, $N_{u,5\%}$ and v_F Check $v_F \leq 20\%$ Determine β_{vF} ⁽⁵⁾ Determine α (using Ref TS 4) ⁽⁵⁾ ; $\alpha_{reqd}=0.8$ Assessment as per 8.2.2	7.5	TC, DC, UC, CS	C
			0.5	All	$d_{cut,max}$	5		Determine $N_{u,m}$, $N_{u,5\%}$ and v_F Check $v_F \leq 20\%$			

Test Series No.	Title	Concrete strength	Crack width Δw [mm]	Anchor diameters to be tested ⁽¹⁾	Drill bit cutting diameter range (d_{cut})	Min. No. of samples to be tested for each anchor size	Other deviations from standard Installation and test conditions, if any	Measurement and Assessment checks (TS – Test Series) ⁶	Test Reference section	Test applicable to ⁽²⁾	Assessment option
(1)	(2)	(3)	(4)	(5)	(6)	(7)	(8)	(9)	(10)	(11)	(12)
								Determine β_{vF} ⁽⁵⁾ Determine α (using Ref TS 6) ⁽⁵⁾ ; $\alpha_{reqd}=0.8$ Assessment as per 8.2.2			
9	Maximum crack width & small hole diameter ⁽⁴⁾	High	0	S/M/L	$d_{cut,min}$	5		Determine $N_{u,m}$, $N_{u,5\%}$ and v_F Check $v_F \leq 20\%$ Determine β_{vF} ⁽⁵⁾ Determine α (using Ref TS 5) ⁽⁵⁾ ; $\alpha_{reqd}=1.0$ Assessment as per 8.2.2	7.5	TC, DC, UC, CS	C
			0.5	All	$d_{cut,min}$	5		Determine $N_{u,m}$, $N_{u,5\%}$ and v_F Check $v_F \leq 20\%$ Determine β_{vF} ⁽⁵⁾ Determine α (using Ref TS 7) ⁽⁵⁾ ; $\alpha_{reqd}=0.8$ Assessment as per 8.2.2		TC, DC, UC, CS	B
10	Crack cycling test ⁽⁴⁾	Standard	0.1-0.3	All	$d_{cut,max}$	5		For residual load test: Determine $N_{u,m}$, $N_{u,5\%}$ and v_F Check $v_F \leq 20\%$ Determine β_{vF} ⁽⁵⁾ Determine α (using Ref TS 6) ⁽⁵⁾ ; $\alpha_{reqd}=0.9$ Assessment as per 8.2.2 and 8.2.9(b)	7.6	TC, DC	B
				All	$d_{cut,m}$	5				UC, CS	B
11	Repeated load test	Standard	0	M	$d_{cut,m}$	5		For residual load test: Determine $N_{u,m}$, $N_{u,5\%}$ and v_F Check $v_F \leq 20\%$ Determine β_{vF} ⁽⁵⁾ Determine α (using Ref TS 4) ⁽⁵⁾ ; $\alpha_{reqd}=1.0$ Assessment as per 8.2.2	7.7	TC, DC, UC, CS	B,C
				High	0	M	$d_{cut,m}$			5	

Test Series No.	Title	Concrete strength	Crack width Δw [mm]	Anchor diameters to be tested ⁽¹⁾	Drill bit cutting diameter range (d_{cut})	Min. No. of samples to be tested for each anchor size	Other deviations from standard Installation and test conditions, if any	Measurement and Assessment checks (TS – Test Series) ⁶	Test Reference section	Test applicable to ⁽²⁾	Assessment option
(1)	(2)	(3)	(4)	(5)	(6)	(7)	(8)	(9)	(10)	(11)	(12)
12	Robustness of sleeve down type DC anchor	Stand ar	0	All	$d_{cut,m}$	5	Reference expansion+2 blows with impact device	Determine $N_{u,m}$, $N_{u,5\%}$ and v_F Check $v_F \leq 20\%$ Determine β_{vF} ⁽⁵⁾ Determine α (using Ref TS 4) ⁽⁵⁾ ; $\alpha_{reqd}=0.8$ Assessment as per 8.2.2	7.5	DC	C
		Stand ar	0.5	All	$d_{cut,m}$	5		Determine $N_{u,m}$, $N_{u,5\%}$ and v_F Check $v_F \leq 20\%$ Determine β_{vF} ⁽⁵⁾ Determine α (using Ref TS 6) ⁽⁵⁾ ; $\alpha_{reqd}=0.8$ Assessment as per 8.2.2		DC	B
13	Torquing in standard concrete	Stand ar	0	All	$d_{cut,max}$	10	Minimum embedment	Determine $T_{u,5\%}$ and β_{vF} ⁽⁵⁾ Check $v_F \leq 15\%$ Assessment as per 8.2.6	7.8 and 7.8.1	CS	C
14	Torquing in high strength concrete	High	0	All	$d_{cut,min}$	10		Determine $T_{u,5\%}$ and β_{vF} ⁽⁵⁾ Check $v_F \leq 15\%$ Assessment as per 8.2.6			
15	Impact screw driver	Stand ar	0	All	$d_{cut,max}$	15	Minimum embedment	Assessment as per 8.2.7	7.8 and 7.8.2	CS	C
		High	0	All	$d_{cut,min}$	15	Maximum embedment				
16	Robustness to variation in use conditions ⁽⁴⁾	Stand ar	0	S/M/L	$d_{cut,m}$	5	Installation as per 6.6 and 6.6.12	$v_F < 20\%$ Determine β_{vF} ⁽⁵⁾ Determine α (using Ref TS 4) ⁽⁵⁾ Assessment as per 8.2.4	7.5 and 7.5.2	TC, DC, UC, CS	C
		High	0.3	All	$d_{cut,m}$	5	Installation as per 6.6 and 6.6.12	$v_F < 20\%$ Determine β_{vF} ⁽⁶⁾ Determine α (using Ref TS 7) ⁽⁵⁾ Assessment as per 8.2.4		TC	B
		Stand ar	0.3	All			Installation as per 6.6 and 6.6.12	$v_F < 20\%$ Determine β_{vF} ⁽⁶⁾ Determine α (using Ref TS 6) ⁽⁵⁾ Assessment as per 8.2.4		UC, DC, CS	B
17	Minimum edge & spacing test	Stand ar	0	All	$d_{cut,m}$	5 (double)	Anchor group as per 7.9	Assessment as per 8.2.5	7.9	TC, DC, UC, CS	B,C

Test Series No.	Title	Concrete strength	Crack width Δw [mm]	Anchor diameters to be tested ⁽¹⁾	Drill bit cutting diameter range (d_{cut})	Min. No. of samples to be tested for each anchor size	Other deviations from standard Installation and test conditions, if any	Measurement and Assessment checks (TS – Test Series) ⁶	Test Reference section	Test applicable to ⁽²⁾	Assessment option
(1)	(2)	(3)	(4)	(5)	(6)	(7)	(8)	(9)	(10)	(11)	(12)
						anchor group)					
18	Characteristic edge distance test	Standard	0	All	$d_{cut,m}$	4	$c = c'_{cr,sp}$ from both edge $D = D_{min}$	Determine $N_{u,m}$, $N_{u,5\%}$ and v_F Check $v_F \leq 15\%$ Assessment as per 8.2.8	7.5 and 7.5.1	TC, DC, UC, CS	B,C
19	Robustness to contact with reinforcement	Standard	0.3	S/M	$d_{cut,m}$	5	Installation as per 6.6 and 6.6.13	Determine $N_{u,m}$, $N_{u,5\%}$ and v_F $v_F < 20\%$ Determine β_{vF} ⁽⁵⁾ Determine α (using Ref TS 4) ⁽⁵⁾ Assessment as per 8.2.4	7.5	UC	B
					$d_{cut,max}$					CS	B
20	Steel capacity test in shear	Standard	0	All	$d_{cut,m}$	5		Determine $V_{u,m}$, $V_{u,5\%}$ and v_F Check $v_F \leq 15\%$ Assessment as per 8.3.1 and 8.3.4	7.10	TC, DC, UC, CS	B,C
21	Pry-out test in shear	Standard	0	All	$d_{cut,m}$	5		Determine $V_{u,m}$, $V_{u,5\%}$ and v_F Check $v_F \leq 15\%$ Assessment as per 8.3.2	7.11	TC, DC, UC, CS	C
Seismic tests											
S1	Reference tension tests for seismic evaluation	Standard	0.8	All	$d_{cut,m}$	5		Determine $N_{u,m}$, $N_{u,5\%}$ and v_F $v_F < 20\%$ Determine β_{vF} ⁽⁵⁾ Determine α (using Ref TS 8, cracked) Assessment as per 8.4.2	7.5	TC, DC, UC, CS	A
S2	Reference tension tests for seismic evaluation	High	0.8	All	$d_{cut,m}$	5		Determine $N_{u,m}$, $N_{u,5\%}$ and v_F $v_F < 20\%$ Determine β_{vF} ⁽⁵⁾ Determine α (using Ref TS 9, cracked) Assessment as per 8.4.2	7.5	TC, DC, UC, CS	A
S3	Reference shear test	Standard	0.8	All	$d_{cut,m}$	5		Determine $V_{u,m}$, $V_{u,5\%}$ and v_F $v_F < 15\%$ Determine β_{vF} ⁽⁵⁾ Determine α (using Ref TS 20) Assessment as per 8.4.3	7.10	TC, DC, UC	A
S4	Tests for pulsating tension load	Standard	0.5 to 0.8	All	$d_{cut,m}$	5		For residual load test: Determine $N_{u,m}$, $N_{u,5\%}$ and v_F $v_F < 20\%$ Determine β_{vF} ⁽⁵⁾ Determine α (using TS S1)	7.12	TC, DC, UC, CS	A

Test Series No.	Title	Concrete strength	Crack width Δw [mm]	Anchor diameters to be tested ⁽¹⁾	Drill bit cutting diameter range (d_{cut})	Min. No. of samples to be tested for each anchor size	Other deviations from standard Installation and test conditions, if any	Measurement and Assessment checks (TS – Test Series) ⁶	Test Reference section	Test applicable to ⁽²⁾	Assessment option
(1)	(2)	(3)	(4)	(5)	(6)	(7)	(8)	(9)	(10)	(11)	(12)
								Assessment as per 8.4.4			
S5	Tests for alternating shear load	Standard	0.8	All	$d_{cut,m}$	5		For residual load test: Determine $N_{u,m}$, $N_{u,5\%}$ and v_F $v_F < 15\%$ Determine β_{vF} ⁽⁵⁾ Determine α (using TS S3) Assessment as per 8.4.5	7.13	TC, DC, UC, CS	A
S6	Tension test with varying crack width	Standards	0.8	All	$d_{cut,m}$	5		For residual load test: Determine $N_{u,m}$, $N_{u,5\%}$ and v_F $v_F < 20\%$ Determine β_{vF} ⁽⁵⁾ Determine α (using TS S1) Assessment as per 8.4.6	7.14	TC, DC, UC, CS	A

NOTES

1 A reduced range of anchor sizes indicated by S/M/L only shall be tested. The number of diameters to be tested in this case shall depend on the number of requested sizes and is given in the following tables.

No. of anchor sizes (diameter) requested for assessment by manufacturer	No. of diameters to be tested
≤ 5	3
≤ 8	4
≤ 11	5
> 11	6

2 Some tests are applicable to only certain types of mechanical anchors. The notations used in the above table are as follows:

- TC – Torque-controlled expansion anchors
- DC – Displacement-controlled expansion anchors
- UC – Undercut anchors
- CS – Concrete screws

- 3** In the reference tension tests, if the anchors fail in steel then these tests may be omitted.
- 4** If fewer than three sizes of the anchor are tested together and/or different sizes are not similar in respect of geometry, friction between cone and sleeve (internal friction) and friction between sleeve and concrete (external friction), then the number of tests shall be increased to 10 for all sizes of the anchors.
- 5** If the coefficient of variation is higher than the limit defined for test series then the reduction factor β_{vF} shall be calculated according to **D-4** and applied to the characteristic value. The reduction α shall also be calculated according to **D-5**.
- 6** Nominal concrete strength for normalization of test results as per A-1 for tests in standard concrete is 25 MPa and for high strength concrete is 60 MPa. When comparing to tests, it shall be permitted to normalize the results to concrete strength corresponding to reference test.

ANNEX A
(Clause 2)**LIST OF REFERRED INDIAN STANDARDS**

<i>IS No.</i>	<i>Title</i>
CED 02(25733)	Draft standard on Design of Post-installed Anchorage to Concrete - Code of Practice
CED 02(25734)	Draft standard on Testing and Assessment of performance of Post-installed adhesive anchoring systems
1608 (Part 1) : 2022	Mechanical testing of metals - Tensile testing (<i>first revision</i>)
1893 (Part1) : 2016	Criteria for earthquake resistant design of structures (<i>sixth revision</i>)
456 : 2000	Plain and reinforced concrete - Code of practice (<i>fourth revision</i>)
875	Code of practice for design loads (Other Than Earthquake) for buildings and structures
(Part 1) : 1987	Dead loads - Unit weights of building materials and stored materials (<i>second revision</i>)
(Part 2) : 1987	Imposed loads (<i>second revision</i>)
(Part 3) : 2015	Wind Loads (<i>third revision</i>)
(Part 4) : 2021	Snow Loads
(Part 5) : 1987	Special loads and load combinations (<i>second revision</i>)
16700 : 2023	Criteria for structural safety of tall concrete buildings (<i>first revision</i>)

ANNEX B
(Clauses 6.6.11 and 6.6.12)

EXPANSION OF DISPLACEMENT CONTROLLED ANCHORS

B-1 EXPANSION PROCEDURE

B-1.1 The expansion of displacement controlled anchors shall be achieved by use of an impact device as shown in Fig. 22 to impart standard energy as may be defined by the manufacturer (similar to that of proctor tests conducted to test soil compaction).

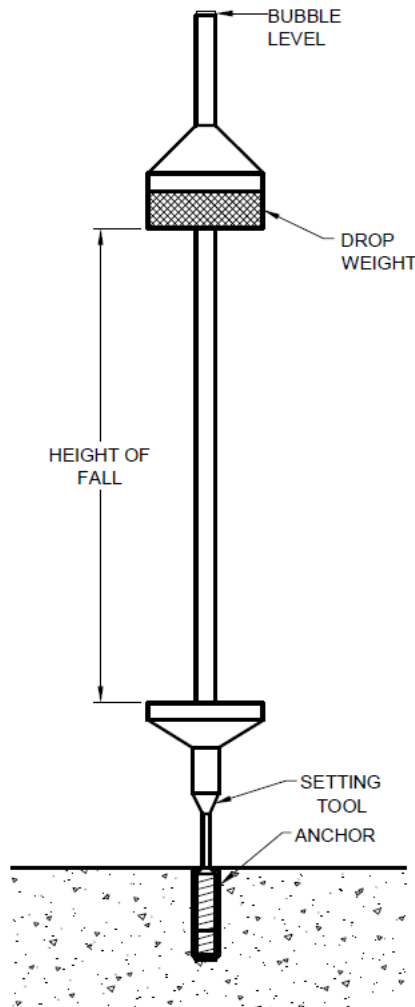

FIG. 22 SCHEMATIC OF ARRANGEMENTS FOR SETTING TESTS (DISPLACEMENT CONTROLLED ANCHOR IS USED AS AN EXAMPLE)

B-1.2 The impact device shall be kept perpendicular to the anchor and the setting tool. Impact device, setting tool and anchor should be in line to prevent energy losses due to additional friction.

B-1.3 The anchor expansion shall be measured before and after application of blows according to Table 10. The anchor expansion shall be measured in terms of the distance between the outer end of the sleeve and the surface of the cone or nail, respectively, for anchors according to Fig. 23(c) to Fig. 23(e).

Table 10 Test Conditions for Setting Tests for Displacement Controlled Anchors
(Clause B-1.3)

Anchor diameter d , in mm	6	8	10	12	16	20
Impact device type	B	B	B	B	C	C
Weight, in kg	4.5	4.5	4.5	4.5	15	15
Height of fall, in mm	450	450	450	450	600	600
Number of blows ¹ for evaluation of reference expansion.	3	5	6	7	4	5
Number of blows ¹ for evaluation of reduced expansion.	2	3	4	5	3	4

Notes –

¹ The tests shall be carried out with a standardized device applying a constant energy per blow. In practice, the energy applied during setting of the anchor by a hand hammer depends on the anchor size. Therefore, the number of blows is different for the different anchor sizes.

B-1.4 If the manufacturer recommends setting of anchor by machine, then it shall be shown that the reduced and reference expansion achieved using machine is at least equal to the corresponding expansion in the robustness test by impact device according to Fig. 22. The robustness tests shall be performed in the same way as described above but using machine setting tool instead of impact device. The setting shall be undertaken vertically upwards by the setting tool with the smallest energy output of the range of machines defined in the MPII. The expansion shall be measured before the first blow and after a maximum of 10 and 15 seconds of setting time. In machine setting tests, reduced expansion and reference expansion shall be achieved on an average after a setting time of maximum 10 seconds and maximum 15 seconds, respectively.

B-1.5 In some types of displacement controlled expansion anchors, the sleeve is expanded by driving in a cone; the extent of expansion in this case is controlled by the length of travel of the cone (Fig. 23A). In other, the sleeve is driven over an expansion element, the extent of expansion is controlled by the travel of the sleeve over the expansion element (Fig. 23B). The expansion forces created during anchor installation along with tension forces are transferred into the concrete mainly by friction. Some of the common types of displacement controlled expansion anchors are – Cone down type anchor e.g., drop-in anchor (Fig. 23C), Sleeve down type anchor (Fig. 23D) and Stud version of sleeve down type anchor (Fig. 23E). Reference expansion (i.e., full expansion) for different types of displacement controlled anchor shall be achieved by setting the anchor according to the MPII, For example: -

- a) For cone down type anchors according to (see Fig. 23C), the shoulder of the setting tool should be flush to the surface of the sleeve
- b) For shank down type anchors according to (see Fig. 23D), the expansion nail should be flush to the stud surface
- c) For sleeve down type anchors according to (see Fig. 23E), the sleeve should be flush to the concrete surface

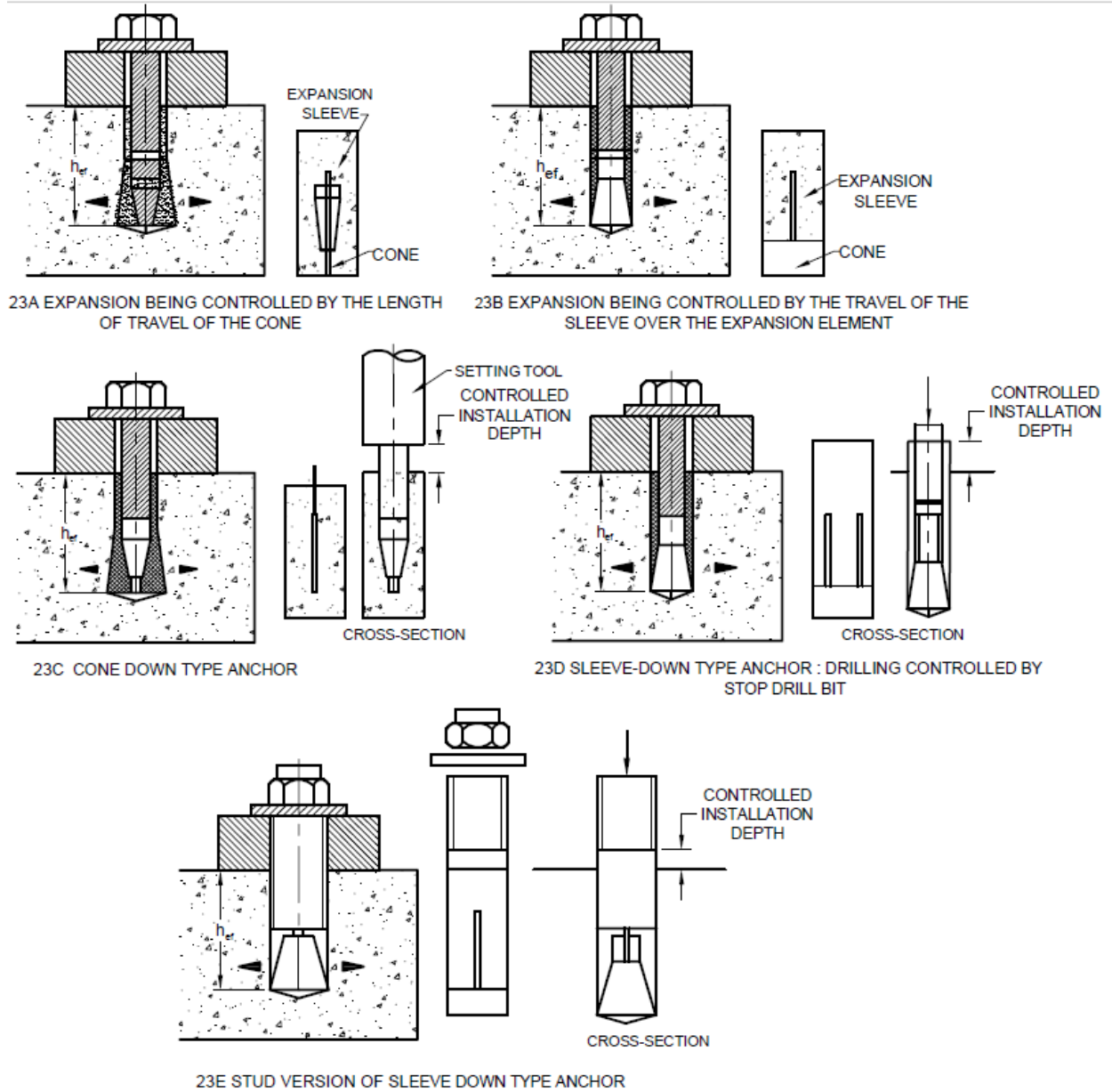

FIG. 23 DISPLACEMENT CONTROLLED EXPANSION ANCHORS

ANNEX C
[Clause 6.6.12(c)]

DIFFERENT TYPE OF UNDERCUT ANCHORS

C-1 UNDERCUT ANCHORS WITH DISPLACEMENT CONTROLLED INSTALALTIONS

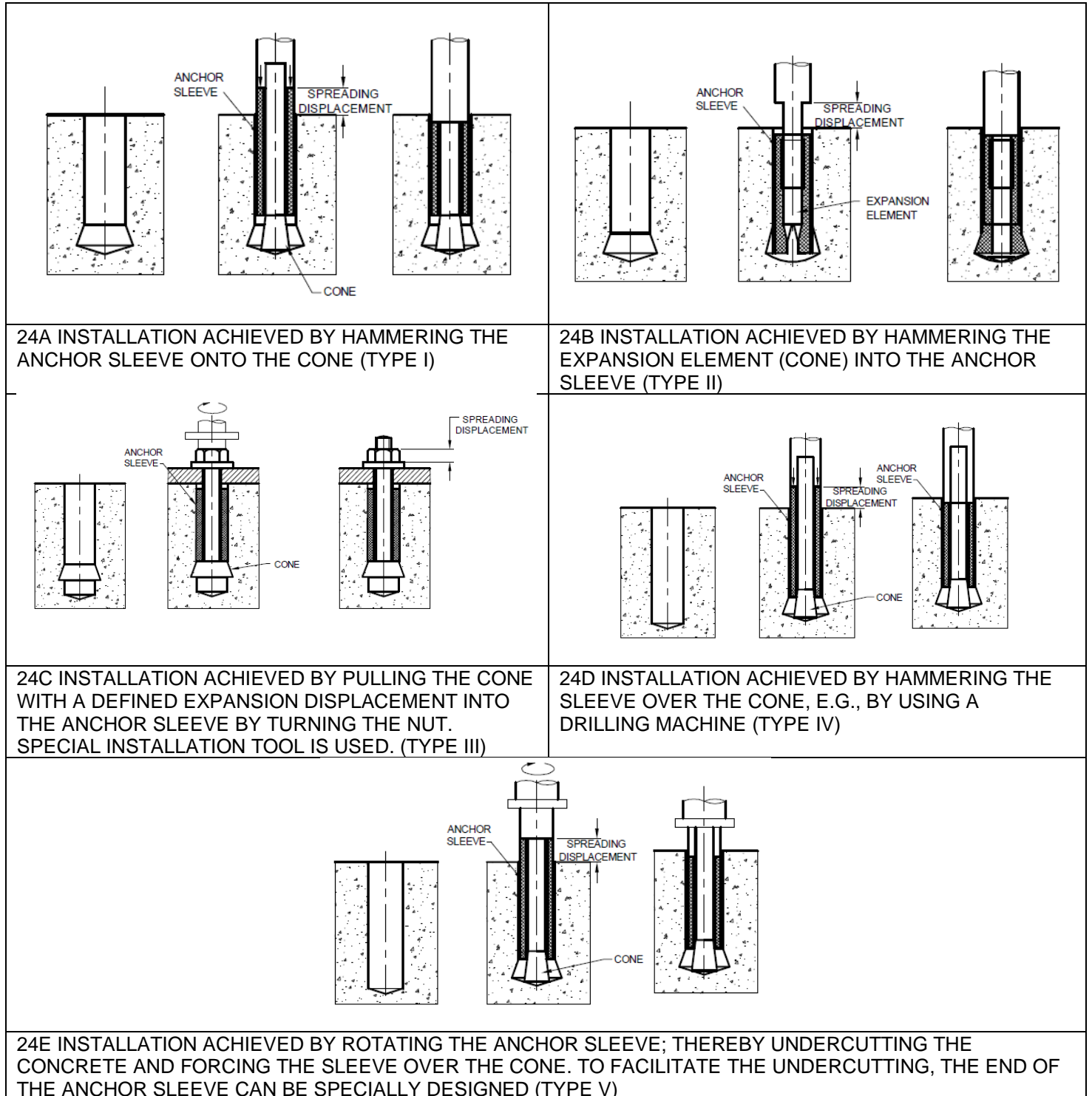

FIG. 24 DISPLACEMENT CONTROLLED INSTALLATION – UNDERCUT (MECHANICAL) ANCHORS

C-2 UNDERCUT ANCHORS WITH TORQUE-CONTROLLED INSTALATIONS

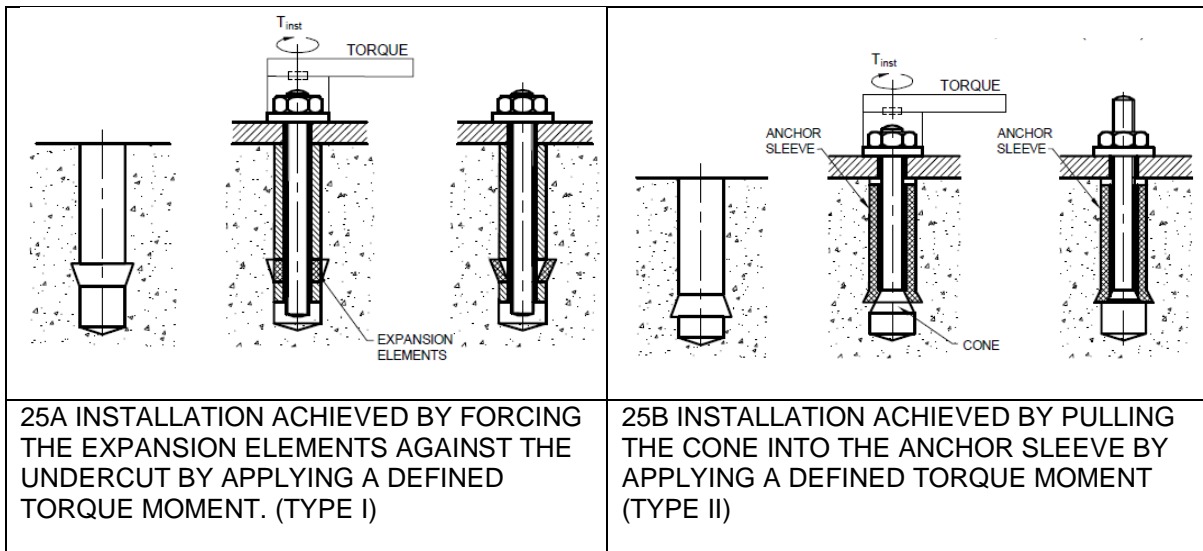

FIG. 25 TORQUE CONTROLLED INSTALLATION – UNDERCUT (MECHANICAL) ANCHORS

ANNEX D

(Clauses 8.1.8, 8.2.1 and 8.2.2)

GENERAL ASSESSMENT METHOD**D-1 CONVERSION OF TEST RESULTS TO NOMINAL STRENGTH**

During conversion of test results to nominal strength the type of failure shall be taken into account.

D-1.1 When the anchor system fails in concrete, the test result shall be normalized to nominal concrete strength f_{cm} as follows:

$$F_{u,c} = F_{u,ts} \left(\frac{f_{cm}}{f_{cm,ts}} \right)^{0.5} \text{ with } f_{cm}/f_{cm,ts} \leq 1$$

where

- $F_{u,ts}$ = Ultimate load measured in a test series,
 $F_{u,c}$ = Ultimate failure load at concrete compressive strength f_{cm} , and
 $f_{cm,ts}$ = Mean compressive cube strength of concrete test member at the time of testing anchor samples.

D-1.2 When the anchor fails in pullout, the test result shall be normalized as follows:

$$F_{u,c} = F_{u,ts} \left(\frac{f_{cm}}{f_{cm,ts}} \right)^{n'} \text{ with } f_{cm}/f_{cm,ts} \leq 1$$

where

- $n' = \log \left(\frac{N_{u,m,ts5}}{N_{u,m,ts4}} \right) / \log(f_{cm,ts5}/f_{cm,ts4}) \leq 0.50$ for uncracked concrete
 $n' = \log \left(\frac{N_{u,m,ts7}}{N_{u,m,ts6}} \right) / \log(f_{cm,ts7}/f_{cm,ts6}) \leq 0.50$ for cracked concrete

NOTE – In case of seismic or seismic assessment, the normalization exponent (n') shall be taken as 0.5 for concrete related failure modes.

D-1.3 When the anchor fails in steel, the test result shall be normalized to the nominal steel strength f_u as follows:

$$F_{u,s} = F_{u,ts} \left(\frac{f_u}{f_{u,ts}} \right)$$

where

- $F_{u,s}$ = Ultimate failure load at nominal steel ultimate strength f_u ,
 $f_{u,ts}$ = Steel ultimate tensile strength corresponding to anchor used for the test, and
 $F_{u,ts}$ = Ultimate load measured in a test series.

For anchors with sleeve in the shear plane, the results of shear test with steel failure shall be normalized using the following equation:

$$V_{u,m} = V_{u,m,ts} \left(\frac{f_{u,bolt,ts,S5} A_{s,bolt}}{f_{u,bolt,ts,S3} A_{s,a}} + \frac{f_{u,sle,ts,S5} A_{s,sle}}{f_{u,sle,ts,S3} A_{s,a}} \right)$$

D-2 DETERMINATION OF 5th PERCENTILE VALUE

The 5th percentile strength shall be calculated from the ultimate loads measured in a test series according to statistical procedures for a confidence level of 90%. A normal distribution and an unknown standard deviation of the population shall be assumed. The 5th percentile strength shall be determined as follows:

$$F_{u,5\%} = F_{u,m,ts}(1 - k_s v_F)$$

where

- $F_{u,5\%}$ = 5th percentile value of the ultimate load in a test series,
 $F_{u,m,ts}$ = Mean ultimate load in a test series,
 v_F = Coefficient of variation [%] related to loads, and
 k_s = Owens no. [$k_s = 3.4$ and 2.57 for test series with 5 and 10 samples, respectively].

D-3 DETERMINATION OF 95th PERCENTILE VALUE

The 95th percentile value shall be calculated from the ultimate loads measured in a test series according to statistical procedures for a confidence level of 90%. A normal distribution and an unknown standard deviation of the population shall be assumed. The 95th percentile shall be determined as follows:

$$F_{u,95\%} = F_{u,m,ts}(1 + k_s v_F)$$

where

- $F_{u,95\%}$ = 95th percentile of the ultimate load in a test series,
 $F_{u,m,ts}$ = Mean ultimate load in a test series,
 v_F = Coefficient of variation [%] related to loads, and
 k_s = Owens no. [$k_s = 3.4$ and 2.57 for test series with 5 and 10 samples, respectively].

D-4 DETERMINATION OF REDUCTION FACTOR β_{v_F}

D-4.1 If the coefficient of variation of the ultimate load in any reference test series exceeds 15% but is less than 30 percent then the mean ultimate load of that series shall be multiplied with the following reduction factor, β_{v_F} , to accommodate for inconsistent behavior:

$$\beta_{v_F} = 1/[1 + 0.03(v_F - 15)] \leq 1$$

D-4.2 If the coefficient of variation of the ultimate load in any test series other than reference test series (exceptions listed on Table 2) exceeds 20 percent but is less than 30 percent then the mean ultimate load of that series shall be multiplied with the following reduction factor, β_{v_F} , to accommodate for inconsistent behavior:

$$\beta_{vF} = 1/[1 + 0.03(v_F - 20)] \leq 1$$

D-4.3 If the coefficient of variation of the ultimate load exceeds 30 percent then the number of test shall be increased until the criteria for coefficient of variation is met.

D-4.4 This modification factor does not apply to test series where the coefficient of variation is less than 15 percent and 20 percent for reference test series and other test series, respectively.

D-5 DETERMINATION OF REDUCTION FACTOR α

D-5.1 The α reduction factor shall be calculated by comparing the ultimate load and characteristic load of any tension test series (other than reference tests) to corresponding value of reference tension test series as follows:

$$\alpha = \min \left[\left(\frac{F_{u,m,ts}}{F_{u,m,r}} \right), \left(\frac{F_{u,5\%,ts}}{F_{u,5\%,r}} \right) \right] \leq 1$$

D-5.2 It shall not be required to determine ratio of characteristic loads equation given in **A-5.1** if the coefficient of variation of the test series is smaller than or equal to the coefficient of variation of the reference test series or if the coefficient of variation in both test series is less than 15 percent.

D-5.3 If the number of tests in both tests series is greater than 10 then the characteristic value for the purpose of determination of factor may be calculated using k value of 1.645.

D-5.4 For all tests except reference test, the following may be used for comparison:

$$F_{u,m,r} = N_{Rk,c}/0.75$$

$$F_{u,5\%,r} = N_{Rk}$$

where

N_{Rk} = Characteristic resistance based on assessment as per this standard i.e., the value expected to be eventually published in AR].

D-6 CRITERIA ACCEPTABLE LOAD DISPLACEMENT BEHAVIOR

D-6.1 The load-displacement curves shall show a steady increase in load as illustrated in Fig. 26. Any reduction in load and /or a horizontal or near-horizontal part in the load-displacement curve caused due to uncontrolled slip of the anchor shall not be acceptable up to a load of N_{sl} . For tests in cracked concrete and uncracked concrete, N_{sl} shall be taken equal to $0.7N_u$ and $0.8N_u$, respective. N_u is the ultimate failure load of a single test in a test series.

NOTES

1 In case of torque-controlled anchor, uncontrolled slip occurs due to movement of expansion sleeve in the drilled hole. This behavior can be determined from any reduction in load and /or a horizontal or near-horizontal part in the load-displacement curve. In case of occurrence of uncontrolled slip, the displacement of the expansion sleeve relative to its position in the drilled

hole should be recorded by appropriate means during or after the tension tests to ascertain the cause if in doubt about anchor behavior.

2 In case of displacement-controlled anchor, uncontrolled slip occurs due to slippage of sleeve in the drilled hole. Fluctuations in the load-displacement curve as shown in Fig. 27(b) and 27(c), may be caused due to the difference in sliding friction and static friction. A reduction of the load as shown in Fig. 27(d) and 27(e) can also occur in cracked concrete tests due to lowered anchor stiffness. This cannot be considered as uncontrolled slip. The maximum load recorded in the test shall be taken as the ultimate load irrespective of the displacement for displacement-controlled anchors.

3 In case of undercut anchor and concrete screws, uncontrolled slip may occur due to movement of expansion sleeve or expansion element in the drilled hole, caused by failure of stressed concrete in the region of undercut. A reduction in load and/or a horizontal or nearly horizontal part in the load-displacement curve with a corresponding displacement of greater than 0.5 mm are typical for this type of slip.

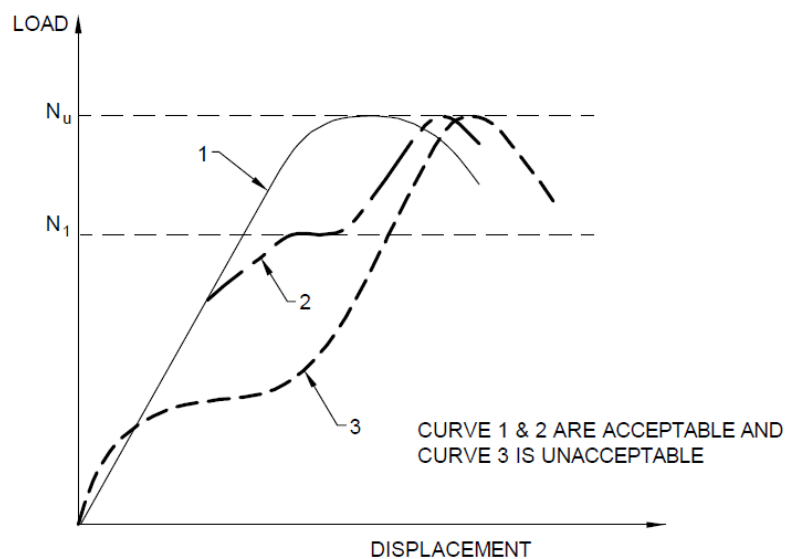

FIG. 26 REQUIREMENT FOR THE LOAD DISPLACEMENT CURVE

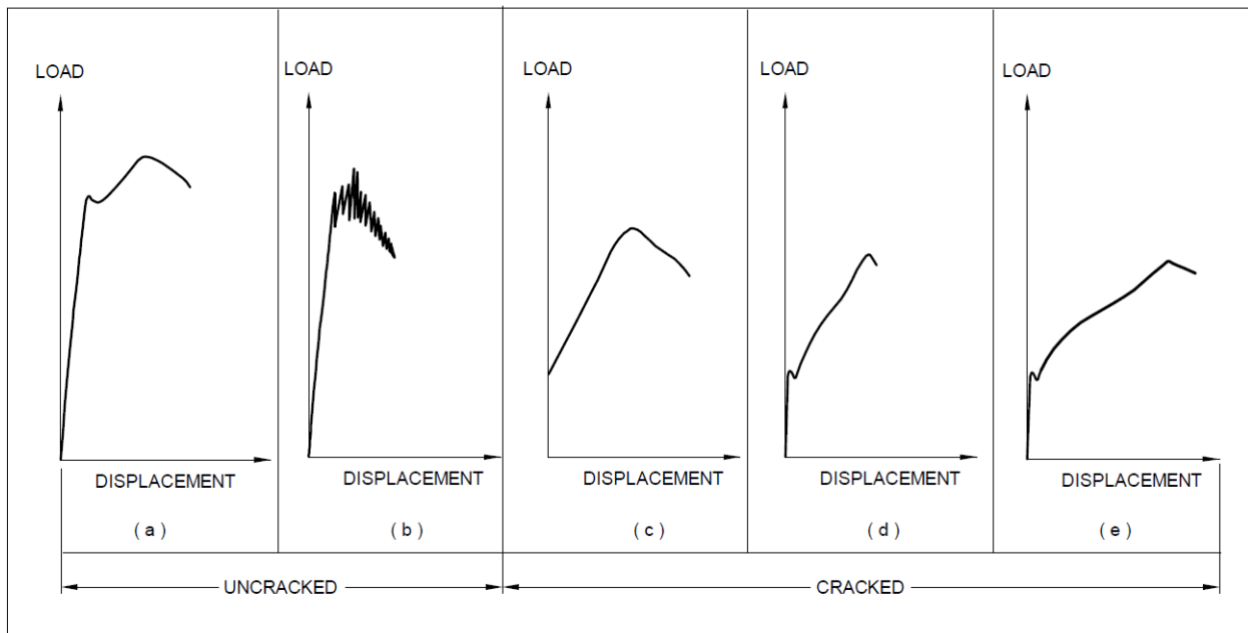

FIG. 27 TYPICAL ACCEPTABLE LOAD DISPLACEMENT BEHAVIOR OF DISPLACEMENT CONTROLLED ANCHORS

D-6.2 If any reduction in load and/or horizontal part in curve is observed in load-displacement curve before reaching the load N_{sl} as defined in **D-6.1**, then the reduction factor α_1 shall be determined for each such test in the test series using the following equation.

$$\alpha_1 = N_{sl,ts} / N_{u,ts}$$

where,

$N_{sl,ts}$ = Load at which uncontrolled slip occurs in the test, and

$N_{u,ts}$ = Ultimate load in the test series

The reduction factor determined using the above equation shall be used to calculate the ratio $\alpha_1 / \alpha_{1,reqd}$, where $\alpha_{1,reqd}$ is 0.7 for tests in cracked concrete and 0.8 for tests in uncracked concrete. The lowest value of the ratio $\alpha_1 / \alpha_{1,reqd}$ determined for all such tests in a test series shall govern.

NOTE – Within an individual test series, this reduction may be omitted if not more than one test shows a load-displacement curve with a short plateau below the load value N_{sl} , provided all of the following conditions are met:

- 1) The deviation is not substantial,
- 2) The deviation can be justified as uncharacteristic of the anchor behavior and is due to a defect in the anchor tested, test procedure, etc.
- 3) The anchor behavior meets the criterion in an additional series of 10 tests.

D-6.3 Uncontrolled slip under sliding friction can be recognized when the extension of the load-displacement curve cuts the displacement axis at displacements δ greater than zero (see Fig. 28A). In this case, the load N_1 shall be defined by the horizontal branch of the load-displacement curve as shown in Fig. 28A. As it may be difficult to draw an extension to a curved line, a line should be drawn connecting the ultimate load and the zero point (see Fig. 28B) for simplification. In this plot, in areas where the load-displacement curve falls below the linear connection between the ultimate load and the zero point should be designated as uncontrolled slip and the load N_1 should be defined as the lower intersection point of the

straight line with the load-displacement curve (see Fig. 28B). In case assessment is done using both methods, then the values obtained using the first method (as shown in Fig. 28A) shall be decisive.

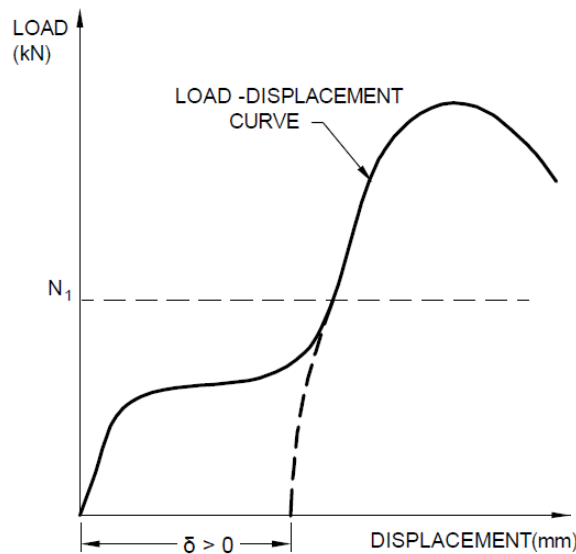

FIG. 28A LOAD DISPLACEMENT BEHAVIOR WITH UNCONTROLLED SLIP

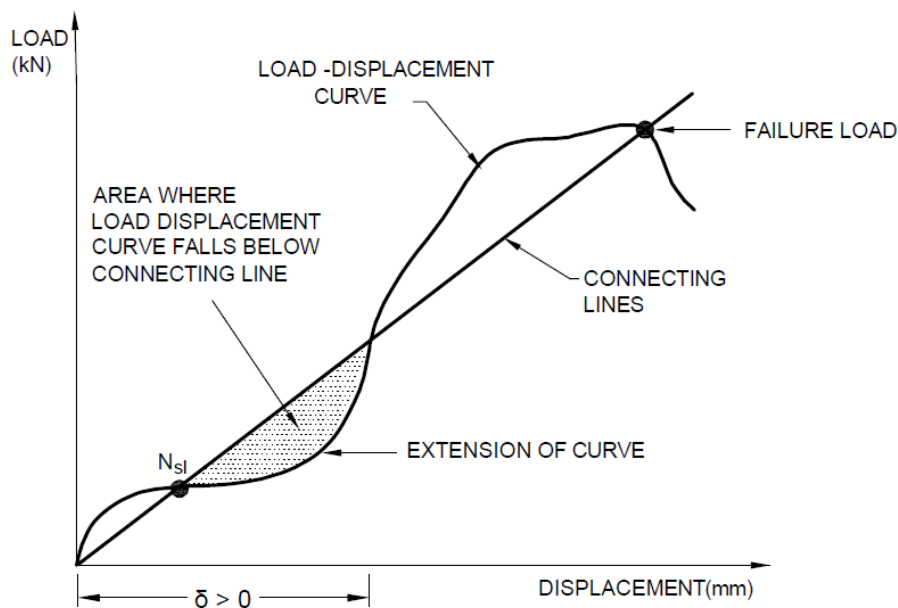

FIG. 28B LOAD DISPLACEMENT BEHAVIOR OF DISPLACEMENT CONTROLLED ANCHOR WITH UNCONTROLLED SLIP

D-7 CRITERIA FOR COEFFICIENT OF VARIATION OF DISPLACEMENT

D-7.1 For reference tests, the coefficient of variation of the anchor displacement at a load corresponding to $0.5 F_{u,m,ts}$ of that test series shall be lower than 25% (that is $v_{\delta} \leq 0.25$). For other tests, this value shall be lower than 40 percent (that is $v_{\delta} \leq 0.40$). It shall be permitted to increase no. of tests in a test series to fulfill this requirement.

D-7.2 The influence of residual prestressing forces on the displacement at a load corresponding to $0.5F_{u,m,ts}$ should be neglected in this evaluation by parallel shifting of all load-displacement curves to the point of lowest remaining prestressing force (see Fig. 29).

D-7.3 It shall not be necessary to observe this limitation on the scatter of the load-displacement curves if in the test series all displacements at a load corresponding to $0.5F_{u,m,ts}$ are smaller than or equal to 0.4 mm.

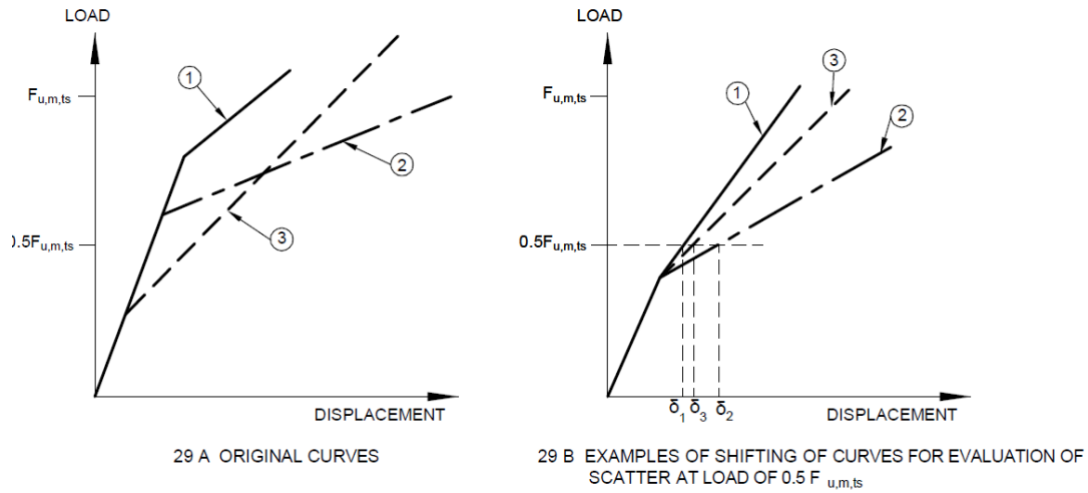

FIG. 29 INFLUENCE OF PRESTRESSING ON LOAD-DISPLACEMENT CURVES

Annex E
(Clause 8.1.9)

SAMPLE FORMAT FOR ASSESSMENT REPORT

E-1 SAMPLE FORMAT FOR ASSESSMENT REPORT (AR)

1. Description of product
NOTE -This section should give an overview of the technical aspects of the product, product types, grades etc.
2. Assumption for assessment
NOTE - This section should give overview of assumption or basis of use and intended design or service life
3. Performance category and assessment method used
NOTE -This section should give information on the assessment type (Option A, B or C) and any other performance criteria.
4. General product drawing, nomenclature and identification markings
NOTE - This section should contain general anchor drawing (without dimensions), the nomenclature used for different parts etc.
5. Material information
NOTE - This section should contain generic information on material that is used to make different parts of anchor along with standard (if applicable).
6. Installation components, condition and instruction
NOTE - This section should contain information on different tools necessary for installation, information on how to install in various conditions, tables for installation parameters etc.
7. Specification of intended use
NOTE – This section should contain information on environment conditions covered, base material information, assumption for applicability of AR for design, supported design method etc.
8. Characteristic resistance table for static conditions for each product type as per assessment (see D-2 and D-3)
9. Characteristic resistance table for seismic conditions for each product type as per assessment (see D-4 and D-5)
10. Information on anchor displacement as per assessment (see D-6 and D-7)

E-2 SAMPLE FORMAT FOR TENSION LOAD FOR STATIC CONDITIONS

Anchor diameter	d_a (mm)	8	10	12	16
Effective embedment depth	h_{ef} (mm)				
Steel failure					
Characteristic steel strength	$N_{Rk,s}$ (kN)				
Partial Safety factor	γ_{Ms}				
Pullout failure					
Characteristic pullout strength in M25 grade uncracked concrete	$N_{Rk,p}$ (kN)				
Characteristic pullout strength in M25 grade cracked concrete	$N_{Rk,p}$ (kN)				
Installation Safety factor	γ_{inst}				
Anchor strength increasing factor for different concrete grades (Ψ_c)	Ψ_c				
Concrete cone and splitting factor					
Critical spacing	$s'_{cr,N}$				

	$s'_{cr,sp}$				
Critical edge distance	$c'_{cr,N}$				
	$c'_{cr,sp}$				
Partial safety factor	γ_{inst}				
	γ_{Mc}				

E-3 SAMPLE FORMAT FOR SHEAR LOAD FOR STATIC CONDITIONS

Anchor diameter	d_a (mm)	8	10	12	16
Effective embedment depth	h_{ef} (mm)				
Steel failure without lever arm					
Characteristic steel strength	$V_{Rk,s}$ (kN)				
Partial Safety factor	γ_{Ms}				
Ductility factor	k_1				
Steel failure with lever arm					
Characteristic steel strength	$M_{Rk,s}^0$ (kN)				
Partial Safety factor	γ_{Ms}				
Concrete pry out					
Pry out factor	k_{cp}				
Partial safety factor	γ_{Mc}				
Concrete edge failure					
Effective length of anchor in shear loading	l				
Partial safety factor	γ_{Mc}				
Critical edge and spacing					
Critical spacing	$s'_{cr,v}$ (mm)				
Critical edge distance	$c'_{cr,v}$ (mm)				

E-4 SAMPLE FORMAT FOR TENSION LOAD FOR SEISMIC CONDITIONS

Anchor diameter	d_a (mm)	8	10	12	16
Effective embedment depth	h_{ef} (mm)				
Steel failure					
Characteristic steel strength	$N_{Rk,s,seis}$ (kN)				
Partial Safety factor	γ_{Ms}				
Pullout failure					
Characteristic pullout strength in M25 grade cracked concrete	$N_{Rk,p,seis}$ (kN)				
Partial Safety factor	γ_{inst}				
Concrete cone failure					
Partial safety factor	γ_{Mc}				
Splitting failure					
Partial safety factor	γ_{Mc}				

E-5 SAMPLE FORMAT FOR SHEAR LOAD FOR SEISMIC CONDITIONS

Anchor diameter	d_a (mm)	8	10	12	16
------------------------	------------	---	----	----	----

Effective embedment depth	h_{ef} (mm)				
Steel failure					
Characteristic steel strength	$V_{Rk,s,seis}$ (kN)				
Partial Safety factor	γ_{Ms}				
Concrete pry out and concrete edge failure					
Partial Safety factor	γ_{Mc}				

E-6 Sample Format for Displacements for Static Conditions

Anchor diameter	d_a (mm)	8	10	12	16
Effective embedment depth	h_{ef} (mm)				
Displacement under tension					
Tension load in uncracked concrete	N (kN)				
Corresponding displacement	δ_{N0} (mm)				
	$\delta_{N\infty}$ (mm)				
Tension load in cracked concrete	N (kN)				
Corresponding displacement	δ_{N0} (mm)				
	$\delta_{N\infty}$ (mm)				
Shear load in cracked and uncracked concrete	V (kN)				
Corresponding displacement	δ_{V0} (mm)				
	$\delta_{V\infty}$ (mm)				

E-7 SAMPLE FORMAT FOR DISPLACEMENTS FOR SEISMIC CONDITIONS

Anchor diameter	d_a (mm)	8	10	12	16
Effective embedment depth	h_{ef} (mm)				
Displacement @ DLS in Tension	$\delta_{N,seis(DLS)}$ (mm)				
Displacement @ ULS in Tension	$\delta_{N,seis(ULS)}$ (mm)				
Displacement @ DLS in Shear	$\delta_{V,seis(DLS)}$ (mm)				
Displacement @ ULS in Shear	$\delta_{V,seis(ULS)}$ (mm)				

ANNEX F

PROCEDURE FOR ISSUING ASSESSMENT REPORT

A suggestive format for the body engaged in assessing and reporting of anchors is given in Fig. 30.

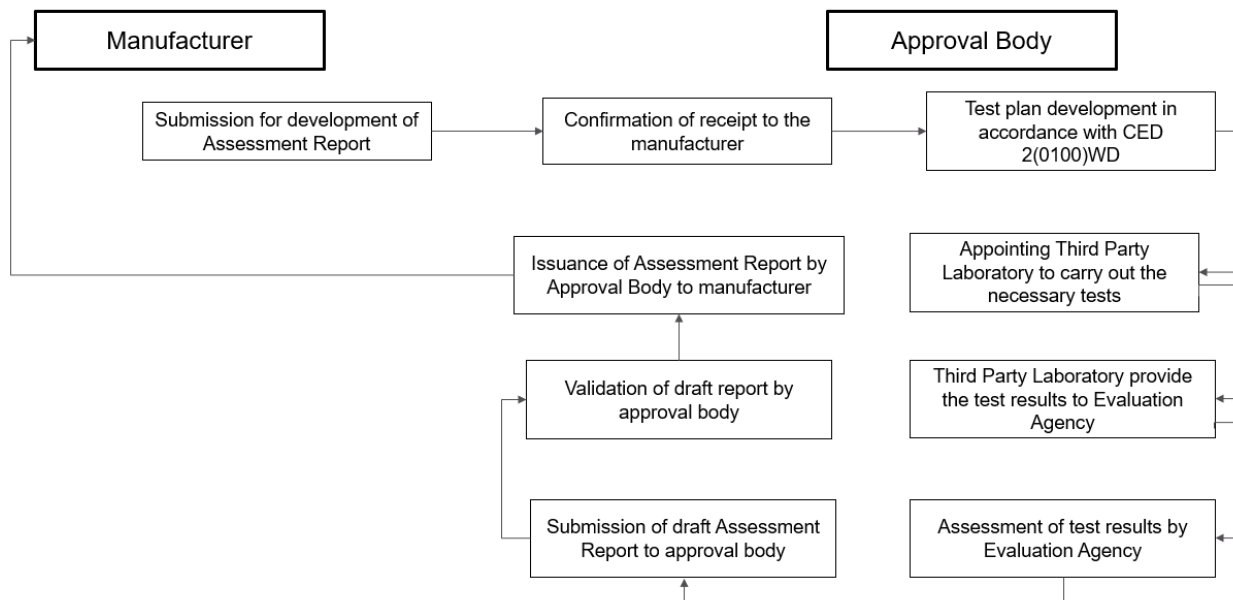

FIG. 30 PROCEDURE OF ASSESSMENT AND REPORTING OF ANCHORS

The following lists the role of respective parties involved in the assessment:

- a) *Approval Body* – It may be an institute of national acceptance/recognition having experience in the field of testing and assessment of post installed anchors.
- b) *Third Party Laboratory* – It may be an independent accredited laboratory or in-house test laboratories of the approval body having experience in the field of testing post installed anchors.
- c) *Evaluation Agency* – It may preferably be an independent institute of national recognition with proven experience in the field of assessment of post installed anchors. They may be the same as Approval Body or separately established.

Limited and isolated research work is available/carried out on date in the country and there is a need for comprehensive testing and assessment of post installed anchors considering the increasing use of such anchors in the country. Adequate training to such bodies and competence development is thus essential so as to have the competent bodies within the country to issue the test reports.

Users of anchors are encouraged to verify the testing/assessment reports issued by reputed bodies who could demonstrate independently the above mentioned criteria.

Annex G

(Committee composition will be added after finalization)
