



## भारतीय मानक ब्यूरो

(उपभोक्ता मामले, खाद्य एवं सार्वजनिक वितरण मंत्रालय, भारत सरकार)

BUREAU OF INDIAN STANDARDS

मानक भवन, 9, बहादुर शाह ज़फर मार्ग, नई दिल्ली - 110002

Manak Bhawan, 9, Bahadur Shah Zafar Marg, New Delhi - 110002

Phones: 23230131 / 2323375 / 23239402

Website: [www.bis.gov.in](http://www.bis.gov.in), [www.manakonline.in](http://www.manakonline.in)

व्यापक परिचालन मसौदा

हमारा संदर्भ : सीईडी 02:2/टी-106

30 मई 2024

तकनीकी समिति : सीमेंट और कंक्रीट अनुभागीय समिति , सीईडी 02

प्राप्तकर्ता :

1. सिविल अभियांत्रिकी विभाग परिषद, सीईडीसी के सभी सदस्य
2. सीमेंट और कंक्रीट अनुभागीय समिति , सीईडी 02
3. सीईडी 02 की उपसमितियों और अन्य कार्यदल के सभी सदस्य
4. रुचि रखने वाले अन्य निकाय।

महोदय/महोदया,

निम्नलिखित मानक का मसौदा संलग्न है:

प्रलेख संख्या	शीर्षक
सीईडी 02(25734)WC	पोस्ट स्थापित चिपकने वाली एंकरिंग प्रणालियों का परीक्षण और मूल्यांकन (आई सी एस संख्या : 91.100.30)

कृपया इस मसौदे का अवलोकन करें और अपनी सम्मतियाँ यह बताते हुए भेजे कि यह मसौदा प्रकाशित हो तो इन पर अमल करने में आपको व्यवसाय अथवा कारोबार में क्या कठिनाइयां आ सकती हैं।

**सम्मतियाँ भेजने की अंतिम तिथि: 30 जुलाई 2024**

सम्मति यदि कोई हो तो कृपया अधोहस्ताक्षरी को ई-मेल द्वारा [ced2@bis.gov.in](mailto:ced2@bis.gov.in) पर या उपरलिखित पते पर, संलग्न फॉर्मेट में भेजें। सम्मतियाँ बीआईएस ई-गवर्नेंस पोर्टल, [www.manakonline.in](http://www.manakonline.in) के माध्यम से ऑनलाइन भी भेजी जा सकती हैं।

यदि कोई सम्मति प्राप्त नहीं होती है अथवा सम्मति में केवल भाषा संबंधी त्रुटि हुई तो उपरोक्त प्रालेख को यथावत अंतिम रूप दे दिया जाएगा। यदि सम्मति तकनीकी प्रकृति की हुई तो विषय समिति के अध्यक्ष के परामर्श से अथवा उनकी इच्छा पर आगे की कार्यवाही के लिए विषय समिति को भेजे जाने के बाद प्रालेख को अंतिम रूप दे दिया जाएगा।

यह प्रालेख भारतीय मानक ब्यूरो की वेबसाइट [www.bis.gov.in](http://www.bis.gov.in) पर भी उपलब्ध है।

धन्यवाद।

भवदीय

ह/-

द्वैपायन भद्र

वैज्ञानिक ई एवं प्रमुख

सिविल अभियांत्रिकी विभाग

संलग्न: उपरलिखित



भारतीय मानक ब्यूरो

(उपभोक्ता मामले, खाद्य एवं सार्वजनिक वितरण मंत्रालय, भारत सरकार)

BUREAU OF INDIAN STANDARDS

(Ministry of Consumer Affairs, Food & Public Distribution, Govt. of India)

मानक भवन, 9, बहादुर शाह ज़फर मार्ग, नई दिल्ली - 110002

Manak Bhawan, 9, Bahadur Shah Zafar Marg, New Delhi - 110002

Phones: 23230131 / 2323375 / 23239402

Website: [www.bis.gov.in](http://www.bis.gov.in), [www.manakonline.in](http://www.manakonline.in)

**WIDE CIRCULATION DRAFT**

Our Reference: CED 02:2/T-106

30 May 2024

**TECHNICAL COMMITTEE: CEMENT AND CONCRETE SECTIONAL COMMITTEE, CED 02**

**ADDRESSED TO:**

1. All Members of Civil Engineering Division Council, CEDC
2. All Members of Cement and Concrete Sectional Committee, CED 02 and its Subcommittees
3. All Members of Subcommittees, Panels and Working Groups under CED 02
4. All others interested.

Dear Sir/Madam,

Please find enclosed the following draft:

Doc No.	Title
CED 02(25734)WC	Testing and Assessment of Post-Installed Adhesive Anchoring Systems ICS 91.100.30

Kindly examine the attached draft and forward your views stating any difficulties which you are likely to experience in your business or profession, if this is finally adopted as National Standard.

**Last Date for comments: 30 July 2024**

Comments if any, may please be made in the enclosed format and emailed at [ced2@bis.gov.in](mailto:ced2@bis.gov.in) or sent at the above address. Additionally, comments may be sent online through the BIS e-governance portal, [www.manakonline.in](http://www.manakonline.in).

In case no comments are received or comments received are of editorial nature, kindly permit us to presume your approval for the above document as finalized. However, in case comments, technical in nature are received, then it may be finalized either in consultation with the Chairman, Sectional Committee or referred to the Sectional Committee for further necessary action if so desired by the Chairman, Sectional Committee.

The document is also hosted on BIS website [www.bis.gov.in](http://www.bis.gov.in).

Thanking you,

Yours faithfully,

Sd/-

Dwaipayan Bhadra

Scientist 'E' & Head

Civil Engineering Department

Encl: As above



**BUREAU OF INDIAN STANDARDS****DRAFT STANDARD FOR COMMENTS ONLY**

*(Not to be reproduced without the permission of BIS or used as an Indian Standard)*

***Draft Indian Standard*****Testing and Assessment of Post-Installed Adhesive Anchoring Systems**

ICS 91.100.30

---

**Cement and Concrete  
Sectional Committee, CED 02****Last Date for Comments:  
30 July 2024**

---

**FOREWORD**

*(Formal clauses of the standard to be added later)*

Various fastening techniques are used extensively for the transfer of loads into concrete structural elements. One such technique that is, post-installed anchors, installed in hardened structural concrete elements, has become quite common in the last two decades in India. Despite the extensive use of post-installed anchors in construction, the level of adequate knowledge regarding their behaviour is only increasing now.

Failure of connections poses risk to human life and considerable economic consequences. Hence, they should be designed, assessed, and evaluated in accordance with the well-established engineering principles. Suitable guidance is therefore required for proper design of such system to ensure safety. CED 02(25733) has been formulated to fulfil the above requirement.

Testing plays an important role in controlling the quality of anchors being used for such post installed connections. This helps achieve a higher efficiency of the anchors used and greater assurance of the performance of the same in adverse environmental and loading conditions. The test methods used should be simple, direct, and convenient to apply. This standard was formulated with this objective in view. This standard would provide thus the requisite guidance regarding the test regime to be adopted for proper assessment, assessment procedure, selection and thereby design of post installed adhesive anchors for use in concrete.

In the formulation of this standard, assistance has been derived from the following publications:

1. EOTA EAD 330499-01-0601 European Assessment Document – Bonded Fasteners for Use in Concrete

An informative annex (see Annex E) detailing out the procedure for issuance of assessment report has been introduced.

## BUREAU OF INDIAN STANDARDS

### DRAFT STANDARD FOR COMMENTS ONLY

*(Not to be reproduced without the permission of BIS or used as an Indian Standard)*

*Draft Indian Standard*

### Testing and Assessment of Post-Installed Adhesive Anchoring Systems

(ICS 91.100.30)

#### 1 SCOPE

**1.1** This standard covers the tests and assessment methods required for evaluating performance of post-installed adhesive anchors and torque controlled adhesive anchors in concrete when subjected to static or quasi-static, and seismic loading conditions. The evaluation is done to determine suitability of use and derive characteristic values for design purposes. This standard does not cover undercut adhesive anchors.

**1.2** This standard outlines the tests required to evaluate the performance of post installed adhesive anchors and torque controlled adhesive anchors in concrete prior to issuance of the assessment report.

NOTE – This does not apply to quality control measures at site.

**1.3** The testing and assessment of post installed mechanical anchors shall be done by a Third party Testing Laboratory and Evaluation Agency, and Assessment Report (AR) shall be issued by the Approval Body in accordance with this standard. The AR is not project specific.

**1.4** The characteristic values reported in AR shall be used for design of post-installed adhesive anchors and torque controlled adhesive anchors in concrete according to CED 02(25733).

NOTE – It is the sole responsibility of the manufacturer to coordinate with the Third Party Testing Laboratory, the Evaluation Agency and the Approval Body to obtain the AR.

*Commentary – European Technical Assessment (ETA) prepared based on European Assessment Document (EAD) is an example of Assessment Report (AR) which is globally adopted.*

#### 2 REFERENCES

The standards (and documents) given in Annex A contain provisions which, through reference in this text, constitute provisions of this standard. At the time of publication, the editions indicated were valid. All standards are subject to revision, and parties to agreements based on these standards are encouraged to investigate the possibility of applying the most recent editions of the standards given in Annex A.

#### 3 TERMINOLOGY

The terminologies given in this standard shall be read in conjunction with the definition of terms given in CED 02(25733). In addition, the following definitions shall apply:

**3.1 Anchor Component Installation Temperature Range** – The temperature range of the adhesive material and embedded part, immediately prior to installation.

**3.2 Anchor Installation** – The process of installing anchor defined by the manufacturer for the subject anchor, unless otherwise specified.

**3.3 Approval Body** – An organization or group of experts that issue the Assessment Report (AR) for post-installed anchoring system tested and assessed according to applicable testing and assessment standards for the designated use.

**3.4 Bond breaker** – A device (such as, pipes) used to create debonding of rebar with concrete of the test member in specific lengths along the length of the rebar to allow free elongation of the rebar (see Fig. 10A).

**3.5 Characteristic Strength** – The value of resistance to be published in the AR document of a post installed anchor for the respective failure mode to be considered in design.

**3.6 Crack inducers** – A device (such as, metal sheets, PVC sheets, etc.) to induce discontinuity in the concrete test member to steer the direction of formation of crack plane close to the anchors (see Fig. 9).

**3.7 Curing Time** – The elapsed time from end of mixing of components of adhesive material in the drilled hole till it achieves required mechanical properties.

**3.8 Evaluation Agency** – An independent body that evaluates the performance of post-installed anchoring products based on test results carried out by a third party testing laboratory, in accordance with applicable testing and assessment standards for the designated use. This independent body should have proven experience of thorough testing and/ or evaluation of the product(s), compliant with the applicable standards.

**3.9 Installation Temperature Range** – The ambient temperature range of the base material recommended by the manufacturer for installation of post-installed anchors.

**3.10 Open Time** – The time from the point of mixing or activating the adhesive and inserting the fastening element (such as, threaded rod); any movement of the fastening element beyond this time may hamper the performance and strength of the connection.

**3.11 Service Temperature Range** – The range of ambient temperatures after installation and during the service lifetime of the anchorage.

**3.12 Short Term Temperature** – The temperature(s) within the service temperature range which vary over short intervals, like, day/night cycles.

**3.13 Long Term Temperature** — The temperature(s) within the service temperature range which will be approximately constant over significant periods of time, and include constant or near constant temperatures.

**3.14 Test Member** – Concrete member in which the anchor is tested.

**3.15 Test Series** – It comprises of a group of identical anchors tested under identical conditions of anchor diameter, length, embedment, spacing, edge distance, drill hole diameter and depth, concrete density/weight, test member thickness and concrete compressive strength

**3.16 Third Party Testing Laboratories (Accreditation and Calibration)** – Testing laboratories that are accredited by an accreditation body and have experience in anchor testing.

**3.17 Unidirectional Crack** – Crack running in one direction with an almost constant width over the member depth.

**3.18 5<sup>th</sup> Percentile value** – The value with 95 percent probability of being exceeded with a confidence level of 90 percent.

## 4 SYMBOLS AND NOTATIONS

For the purpose of this standard, the following letter symbols shall have the meaning indicated against each; where other symbols are used, they are explained at the appropriate place.

### 4.1 Suffixes

a	—	Anchor
c	—	Concrete
cr	—	Critical
cr'	—	Cracked
uncr'	—	Uncracked
d	—	Design Value
fix	—	Base plate/ fixture
ini	—	Initial
inst	—	Installation
m	—	Mean
M	—	Material
max	—	Maximum
min	—	Minimum
mlt	—	Maximum long term temperature
mst	—	Maximum short term temperature
p	—	Pull-out / bond
r	—	reference test
R	—	Strength/ Resistance
R <sub>k</sub>	—	Characteristic Value
s	—	Steel
sp	—	Splitting
sus	—	Sustained
TS		Test series
TM	—	Test member
u	—	Ultimate
y	—	Yield
5%	—	5 <sup>th</sup> percentile
95%	—	95 <sup>th</sup> percentile

### 4.2 Symbols

$A_s$	—	Stressed cross-section area of anchor
$A_{TM}$	—	Cross-section area of test member
$b$	—	Width of test member
$c'$	—	Distance of anchor from its center to edge of concrete member
$c'_{cr,N}$	—	Critical edge distance of an anchor for concrete cone failure
$c'_{cr,Np}$	—	Critical edge distance of an anchor for bond / pull-out failure.

$c'_{cr,sp}$	—	Critical edge distance of an anchor for splitting failure
$c'_{cr,v}$	—	Critical edge distance of an anchor in shear
$c'_{min}$	—	Minimum edge distance of an anchor
$CF$	—	Centric compression force to be applied on test member in crack cycling test
$D$	—	Concrete member or base material thickness
$d_a$	—	Anchor diameter
$d_{cut}$	—	Cutting diameter of drill bit
$d_{cut,m}$	—	Cutting diameter of drill bit in medium tolerance range
$d_{cut,max}$	—	Cutting diameter of drill bit in maximum tolerance range
$d_{cut,min}$	—	Cutting diameter of drill bit in minimum tolerance range
$d_{fix}$	—	Diameter of clearance hole in base plate/ fixture
$D_{min}$	—	Minimum thickness of concrete member in which the anchor can be installed without damaging the concrete member
$d_0$	—	Drill hole diameter
$f_{ck}$	-	Characteristic cube compression strength of concrete (measured on cube with side length of 150 mm)
$f_{cm}$	—	Mean compressive strength of concrete
$f_u$	—	Ultimate tensile stress for steel
$f_y$	—	Yield strength of steel
$h_{ef}$	—	Effective anchorage/ embedment depth
$h_{iz}$	—	Interaction zone between anchor and concrete
$h_{itz}$	—	Effective load transfer zone of anchors
$\ell_b$	—	Bond length
$\ell_{db}$	—	Debonding length
$N$	—	Normal force; positive in tension, negative in compression
$N_{sus}$	—	Sustained tension load applied on anchor during crack cycling test for anchor evaluation for static load conditions
$N_{Rk,p,uncr}$	—	Characteristic tension strength in uncracked concrete corresponding to bond failure
$N_{TM}$	—	Load applied to test member during crack cycling test (anchor evaluation for static load conditions) to obtain specified crack width movement
$s'$	—	Centre-to-center spacing of anchor in an anchor group
$s'_{cr,N}$	—	Critical spacing between anchors for concrete cone failure
$s'_{cr,Np}$	—	Critical spacing between anchors for pull-out failure
$s'_{cr,sp}$	—	Critical spacing between anchors for splitting failure
$s'_{min}$	—	Minimum spacing between anchors
$T_{inst}$	—	Installation torque
$t_{fix}$	—	Thickness of base plate/ fixture
$V$	—	Shear force
$v$	—	Coefficient of variation (COV); It is the ratio of standard deviation to mean value multiplied by 100%. It is denoted as percentage
$w$	—	Crack width
$\Delta w$	—	Difference in crack width during loading of the anchor and crack width after installing the anchor
$\delta$	—	Displacement



$\gamma$	—	Partial safety factor
$\gamma_{inst}$	—	Partial safety factor for installation
$\alpha$	—	Reduction factor
$\beta_{vF}$	—	Reduction factor for coefficient of variation

## 5 APPARATUS

### 5.1 General Practice

The testing equipment shall be rigid enough to prevent yielding of its components under the anticipated ultimate load to ensure that the applied tension loads remain parallel to the axes of the anchors and that the applied shear loads remain parallel to the surface of the test member during testing. The load application device shall be designed to avoid sudden increase in test load especially at the beginning of the test. In addition to equipment covered in this section, other equipment like spring pots, temperature control chamber or equipment such as freezer/oven, torque wrench, borescope etc. may be required.

### 5.2 Load and Displacement Measuring Device

Calibrated load and displacement measuring devices, having traceable calibration record and conforming to national/ international standards, shall only be used. The measuring error of the load measuring equipment shall not exceed 2 percent. Displacement measuring devices with an accuracy of  $\pm 0.02$  mm or 2 percent for displacements larger than 1 mm shall be used. The measuring error for crack width shall not be greater than 0.02 mm.

### 5.3 Fixture

The load shall be applied to the anchor by a fixture that is representative of the conditions found in practice. Steel fixtures shall be used for applying tension or shear loads during the tests. The diameter of the clearance hole to be provided in the fixture (for example, see Fig. 2a) shall be in accordance with the values given in Table 1.

**Table 1 Size of Clearance Holes in Fixture**  
(Clause 5.3)

Anchor diameter $d^1$ (mm)	Diameter $d_{fix}$ of clearance hole in the base plate (mm)
$d < 10$ mm	$d_{fix} = d + 1$
$10 < d < 24$ mm	$d_{fix} = d + 2$
$d > 24$ mm	$d_{fix} = d + 3$

NOTE

$$^1 d = \begin{cases} d_a, & \text{if bolt bears against the fixture} \\ d_{nom}, & \text{if sleeve bears against the fixture} \end{cases}$$

### 5.4 Unconfined Tension Test Set Up

The device shall be such that the load can be applied concentrically to the anchor. This may be achieved by incorporating hinges between the loading device and the anchor. The load shall be applied to the anchor by a fixture which simulate practical loading scenario. A typical unconfined tension test setup is illustrated in Fig. 1. The test setup shall not restrict the formation of rupture concrete cone (of vertex angle  $120^\circ$ ). To fulfill this requirement, the clear

distance between the support reaction and a single anchor or the outer anchor of anchor group shall be at least  $2h_{ef}$  for tension test. Special arrangements as shown in Fig. 2 should be used for the purpose. The inner diameter of the fixture shall correspond to the sizes given in Table 1. An internally threaded bell shaped fixture connected to pullout rod is thread on to this externally threaded adaptor.

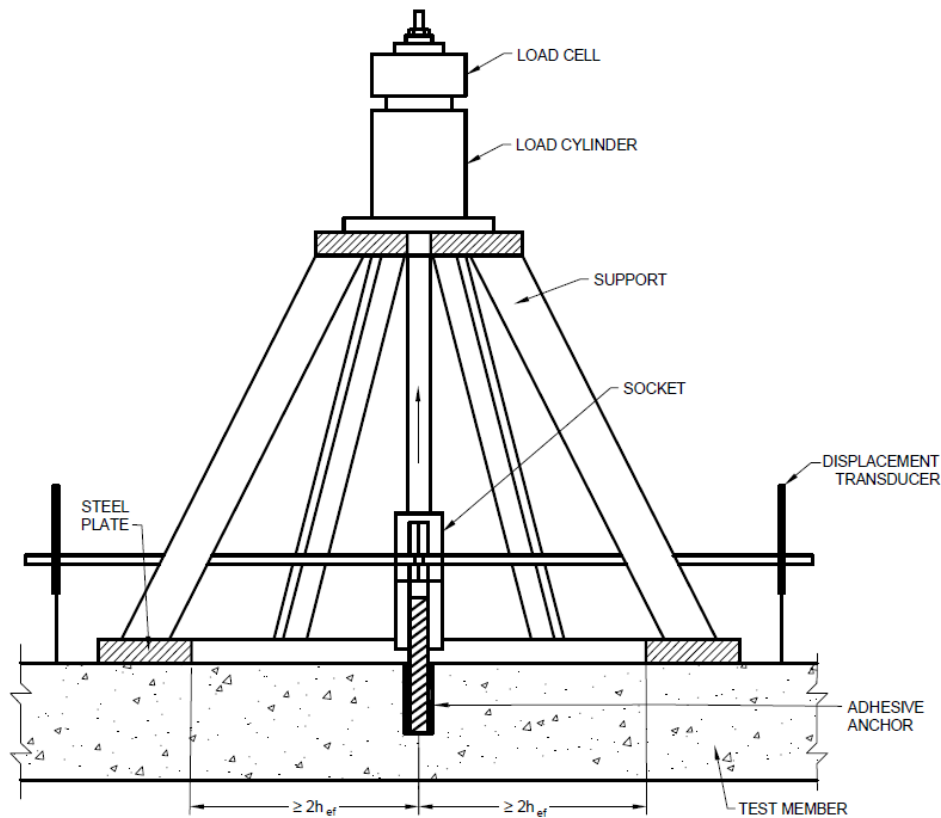

FIG. 1 TYPICAL UNCONFINED TENSION TEST SETUP

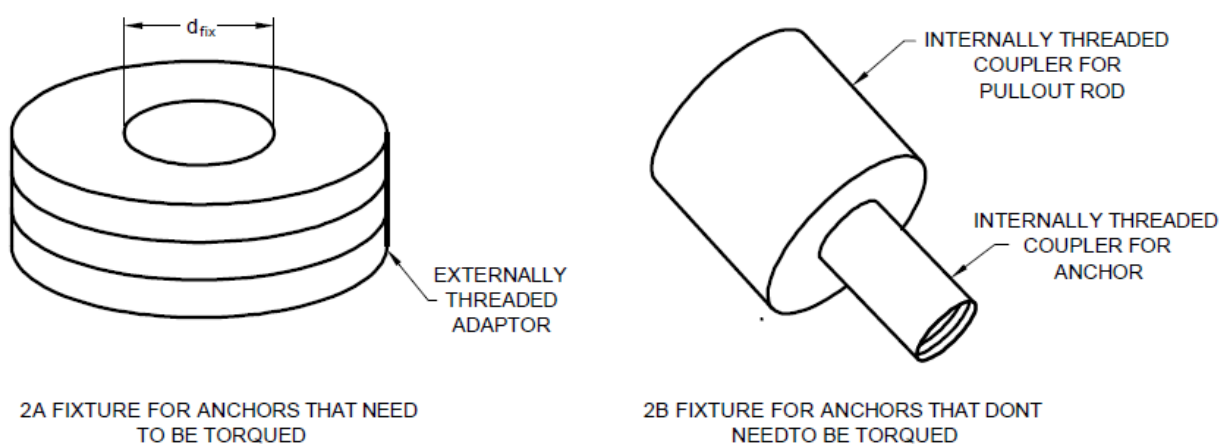

FIG. 2 TYPICAL FIXTURE FOR UNCONFINED TENSION TESTS

### 5.5 Confined Tension Test Set Up

The device shall be such that the load can be applied concentrically to the anchor. This may be achieved by incorporating hinges between the loading device and the anchor. A typical

confined tension test setup is illustrated in Fig. 3. The test setup should restrict the formation of rupture concrete cone. This shall be achieved by using a steel plate. The steel plate required for confined tension test setup should be stiff and the area of support should be large enough to avoid high compressive stresses in concrete. As a recommendation, the compressive stress under the steel plate should be less than 0.7 times of the concrete compressive strength. The clearance hole in steel plate shall be  $1.5d_0$  to  $2d_0$  as shown in Fig. 3. Special adapter as shown in Fig. 2B should be used to load the anchor. The pullout rod is directly thread on to this adapter.

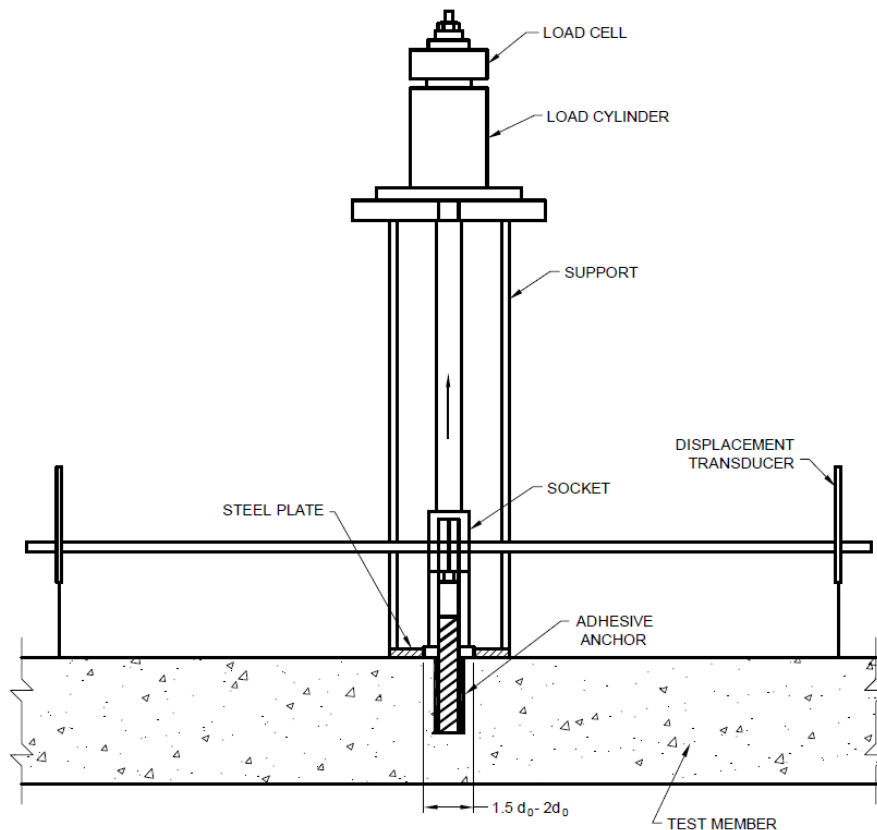

FIG. 3 TYPICAL CONFINED TENSION TEST SETUP

### 5.6 Shear Test Set Up

The device shall be such that the load can be applied parallel to the concrete surface. A plate with interchangeable sleeves may be used for testing anchors of different sizes (see Fig. 4). The sleeves shall be made of hardened steel and have round edges with 0.4 mm radius where in contact with the anchor. The height of the sleeves shall be approximately equal to the outside diameter of the anchor. The inner diameter of the sleeve shall correspond to the sizes given in Table 1. To reduce friction, smooth sheets like Poly-tetra-fluoro-ethylene (PTFE) with a maximum thickness of 2 mm shall be placed between the load plate with sleeve and the test member. A typical horizontal and vertical shear test setup is illustrated in Fig. 5. The test member may be stressed by a torsion moment as there is a lever arm between the applied load and the support reaction. This shall be taken up by placing additional reaction forces sufficiently far away from the anchor. The test setup shall not restrict the formation of rupture concrete cone. To fulfill this requirement, the clear distance between the support reaction and a single anchor or the outer anchor of anchor group shall be at least  $2c'_1$  (edge distance in

direction of the load) for shear test at the edge. It shall be permissible to reduce this clear distance in shear tests without edge influence, where steel failure is expected.

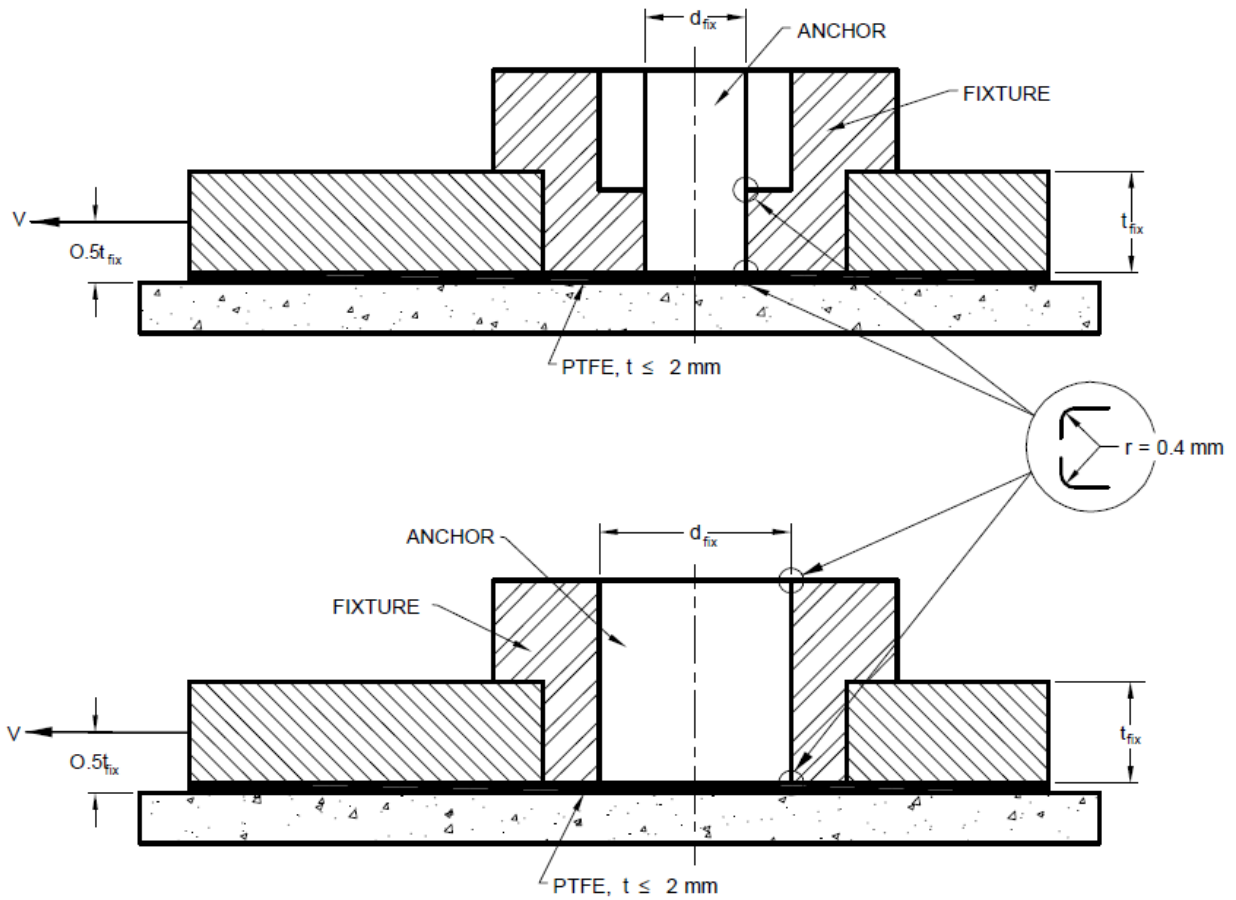
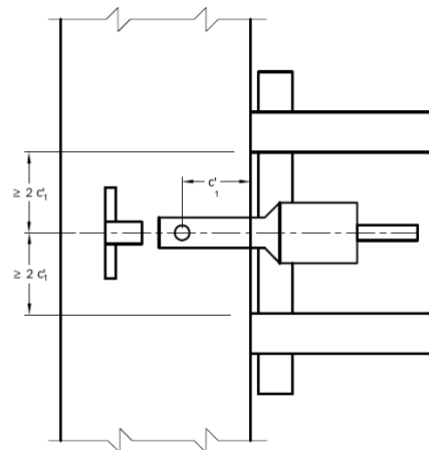

FIG. 4 TYPICAL SHEAR TEST SETUP FIXTURE



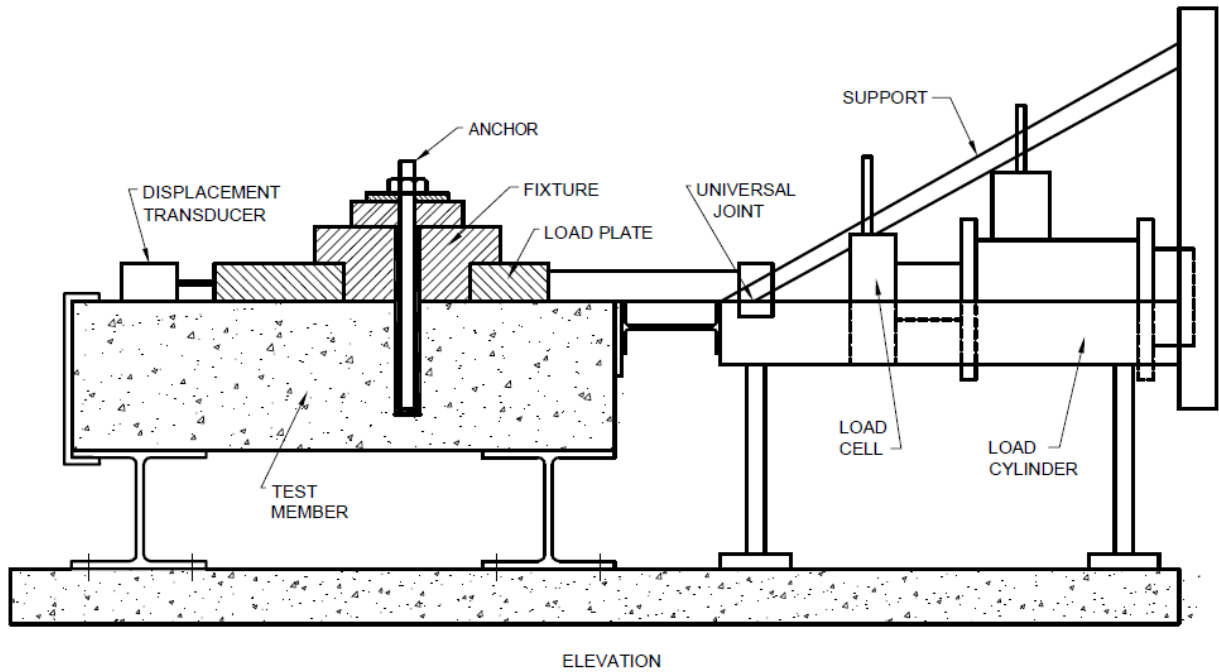

FIG. 5 TYPICAL SHEAR TEST SETUP

### 5.7 Alternating Shear Test Set Up

In addition to the requirements of 5.6, the device shall be such that the uplift of the shear fixture is restrained, that is, significant friction forces are not induced by using roller bearing (see Fig 6). Any exception to annular gap requirement of Table 1 for seismic condition shall be explicitly stated in the AR after testing it accordingly.

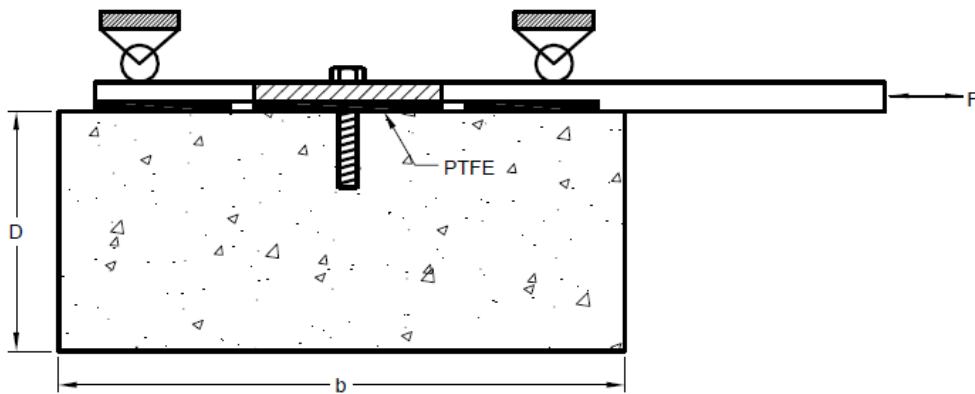

FIG. 6 TYPICAL ALTERNATING SHEAR TEST SETUP

### 5.8 Torque Test Set Up

A calibrated torque wrench and a calibrated load cell shall be used to apply the torque and measure the tensile force generated, respectively. The load cell shall be used as a fixture as shown in Fig. 7. The inner diameter of this fixture ( $d_{fix}$ ) shall correspond to the sizes given in Table 1. The measuring error of the calibrated load cell used for this test should not exceed 3 percent throughout the whole measuring range. Any rotation of the spherical part of the fixture should be prevented.

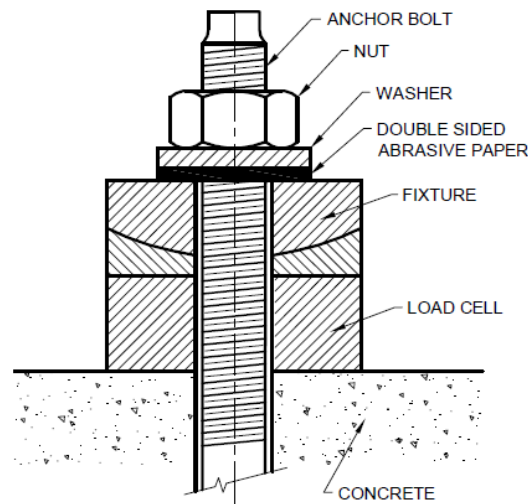

FIG. 7 TYPICAL TORQUE TEST SETUP

### 5.9 Punch Test

A test set up as shown in Fig. 8 shall be used. This test set up shall be such that it permits the metal part, that is, the anchor element of the slice, to be punched through the slice while restraining the surrounding concrete.

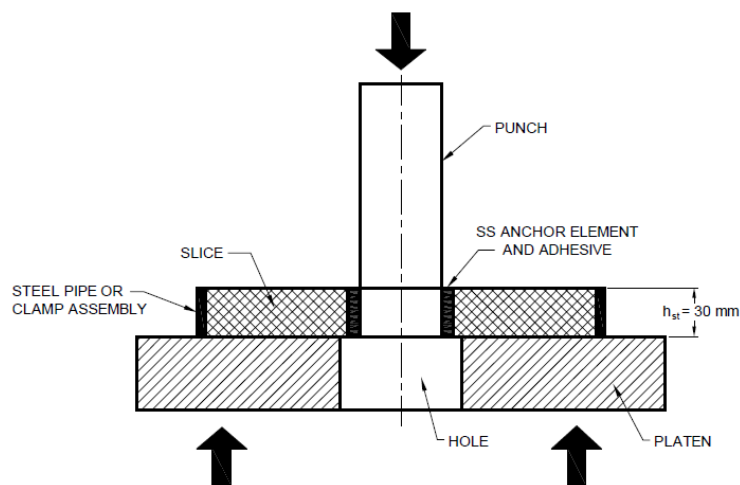

FIG. 8 TYPICAL PUNCH TEST SETUP FOR SLICE TEST

## 6 TEST SPECIMEN

### 6.1 General

**6.1.1** The concrete strength of test member in which the anchor is to be embedded and tested shall be as specified in the test series.

**6.1.2** The average cube compressive strength of 'standard concrete' in the test series shall be in the range of 25 MPa to 35 MPa.

**6.1.3** The average cube compressive strength of 'high strength concrete' shall be in the range of 60 MPa to 70 MPa.

**6.1.4** Test member shall be made of normal weight concrete as per IS 456. The concrete mix, unless otherwise specified, shall not have any additives like fly ash, silica fume, fibers etc. that may alter the concrete properties. The concrete specification and standards shall be clearly documented in the test report.

**6.1.5** The test members shall be cast horizontally with their concrete sampling done as control specimens as test cubes/ cylinders. If cylindrical control specimens are casted, their strength shall be converted into cube strength as per best practice.

**6.1.6** Test members and control specimens shall be cured and stored indoors for seven days. After seven days, the test members and control specimens may be stored outside, provided they are protected from weather conditions such as frost, rain etc. which are likely to cause deterioration of the concrete compression and tension strength. In absence of control specimens, concrete cores from test member may be tested to establish strength at time of testing anchor specimen. The concrete test member shall be at least 28 days old at the time of anchor testing.

**6.1.7** To determine the concrete strength of test member at the time of testing anchor specimen, the concrete control specimens shall be tested on the same day as the anchor test to which they relate. If a test series takes multiple days for completion, then the concrete control specimens should be tested at a time which gives the best representation of the concrete strength at the time of the anchor tests, for example, at the beginning and at the end of the tests. The concrete strength at the time of testing can be determined by interpolation of the results.

**6.1.8** The concrete test member shall be dry at the time of testing, unless noted otherwise in the test series.

**6.1.9** The overall test program for the assessment of adhesive anchors for standard concrete shall be carried out on at least 3 different batches if the concrete comes from different concrete suppliers and on at least 4 different batches if the concrete comes from the same concrete supplier. The overall test program for the assessment of adhesive anchor for high strength concrete shall be carried out on at least 2 different batches if the concrete comes from the same or from different concrete suppliers. If concrete batches come from the same concrete supplier it shall be ensured that each batch is made from a different delivery of either cement or aggregates.

## **6.2 Uncracked Concrete Test Member for Static Tests**

**6.2.1** Test members for uncracked concrete tests shall be unreinforced. Minimal reinforcement may be provided for handling and transportation as per best practice. When test members contain reinforcement to allow handling or for the distribution of loads transmitted by the test equipment, the reinforcement shall be positioned such that the loading capacity of the anchors is not influenced. This requirement shall be considered fulfilled when the reinforcement is located outside the concrete cone area of anchor having a vertex angle of 120°.

**6.2.2** The test member thickness shall be greater than minimum concrete member thickness recommended by the manufacturer ( $D \geq D_{min}$ ).

### 6.3 Cracked Concrete Test Member for Static Tests

**6.3.1** Test members for cracked concrete tests shall be reinforced with reinforcement ratio of the cross section should be about 1 percent and the spacing of the bars not more than or equal to 250 mm. A typical cracked concrete test member is shown in Fig. 9.

NOTE - Cracked concrete member other than recommended in this section shall be permitted as long as it can be demonstrated that the crack requirement of this standard is fulfilled.

**6.3.2** The thickness of the test member shall not be less than  $D_{min}$  as recommended by the manufacturer.

**6.3.3** Crack inducers may be built into the test member to control location and propagation of cracks. The crack inducers shall be located such that they are not close to the anchorage zone and do not influence loading capacity of anchor.

**6.3.4** The cracks shall be unidirectional, and the crack width shall be approximately constant throughout the member thickness.

#### **6.3.5** *Procedure for crack opening to specified crack width*

After anchor is installed in the crack, the crack shall be widened to the specified crack width, as stated in each test series, prior to loading. This process of installation of anchor in crack, followed by crack widening is explained as follows:

- a) The crack (also referred to as "hairline" crack) shall be first initiated / created in the concrete test member using crack inducers as explained herein before.
- b) The anchor shall then be installed at the location of the hairline crack. Depending on the type and size of the anchor to be tested, the crack width may slightly change during the installation procedure. This value should be noted as the crack width after the installation of the anchor.
- c) After installation, the crack width measuring device should be set to zero. The crack width shall be then opened to the specified value  $\Delta w$ . After crack is widened to the specified value, the anchor shall be loaded.



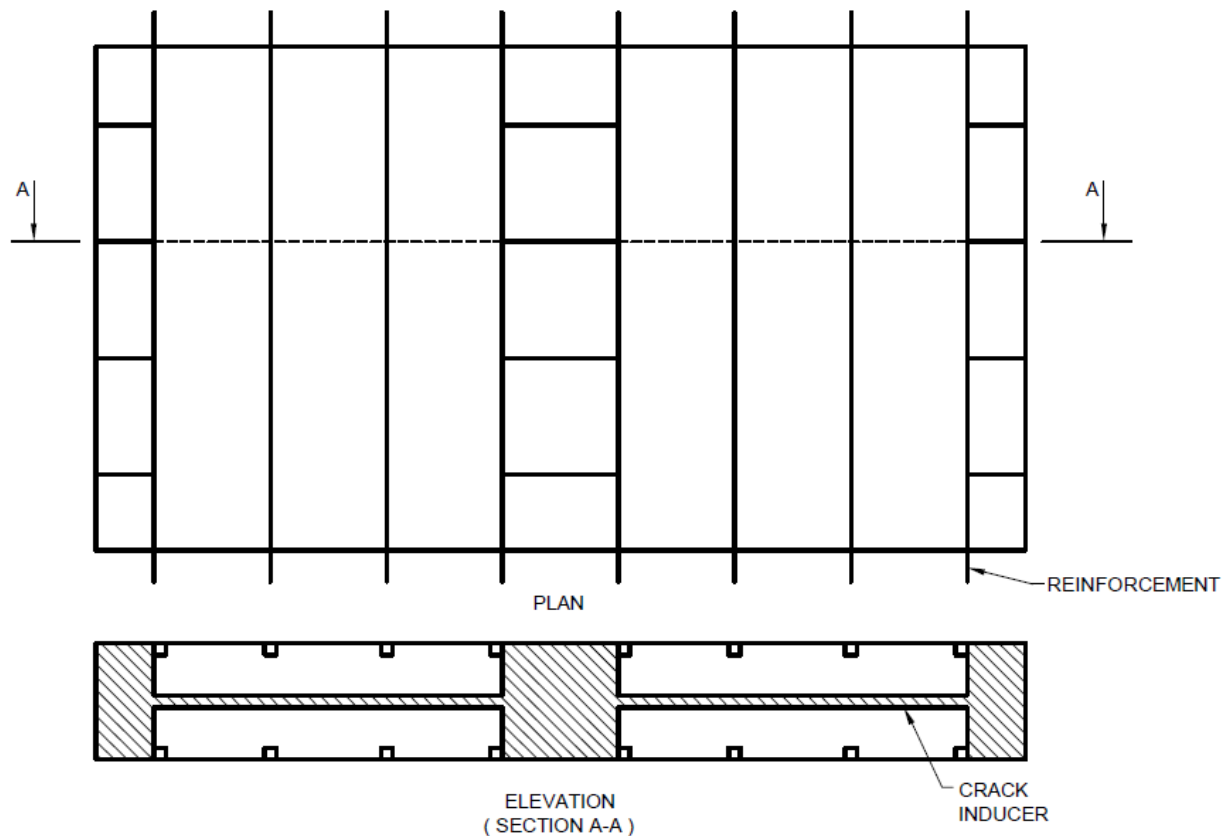

FIG. 9 TYPICAL CRACKED CONCRETE TEST MEMBER

#### 6.4 Cracked Concrete Test Member for Crack Cycling and Seismic Tests

**6.4.1** Test members for cracked concrete condition for seismic tests shall be reinforced. The reinforcement ratio of the cross section should be about 1 percent and the spacing of the bars should be less than or equal to 400 mm. The reinforcement used shall be of equal diameter and placed symmetrically. The reinforcement shall remain in elastic range during each test. The bond length ( $\ell_b$ ) between the potential crack planes and at both end of test member shall be such that the introduction of tension force into concrete is possible (see Fig. 10).

NOTE – Cracked concrete member other than recommended in this section shall be permitted as long as it can be demonstrated that the crack requirement of this standard are fulfilled.

**6.4.2** The thickness of the test member shall not be less than  $D_{min}$  as recommended by the manufacturer. The width of test member shall be large enough to avoid edge influence on anchor behavior. The width requirement shall be considered fulfilled if the concrete cone breakout does not intersect with edge or the edge distance of anchor in all directions is greater than  $2h_{ef}$ .

**6.4.3** To facilitate opening of crack width as required for the test series, a bond breaker (such as, plastic pipe) may be applied at both sides of the crack.

NOTE - A plastic pipe with an inner diameter of about 1.2 times the reinforcement diameter may be used. The debonding length ( $\ell_{db}$ ) should be about 5 times the reinforcement diameter

**6.4.4** The cracks shall be unidirectional, and the crack width shall be approximately constant throughout the member thickness.

**6.4.5** At least three test members shall be tested during designing the cracked concrete member to establish constant crack width for anchor with highest ultimate load to be tested in this member in tension.

**6.4.6** The crack width at the level of embedment and at the top surface of test member where anchor is installed shall be measured as illustrated in Fig. 11. The constant crack width requirement shall be deemed to be established if the ratio of crack width measured at location 3 & 4 to location 1 & 2 is less than 1.05 and the crack width at the level of embedment (location 5 & 6) as illustrated in Fig. 11 is greater than or equal to the specified crack width.

**6.4.7** The anchor test location shall be selected such that the reinforcement does not influence the anchor performance (that is, reinforcement should not be in expected concrete cone area). This requirement shall be considered fulfilled if the distance between the anchor and the nearest reinforcement ( $a_s$ ) is at least greater of 75 mm and  $0.6h_{ef}$  (see Fig. 10A). For confined tests, this spacing requirement shall not apply. If this distance requirement cannot be fulfilled for anchors with large embedment depth with reinforcement spacing of less than 400 mm, then it shall be established during test that the reinforcement does not intersect with concrete cone breakout area.

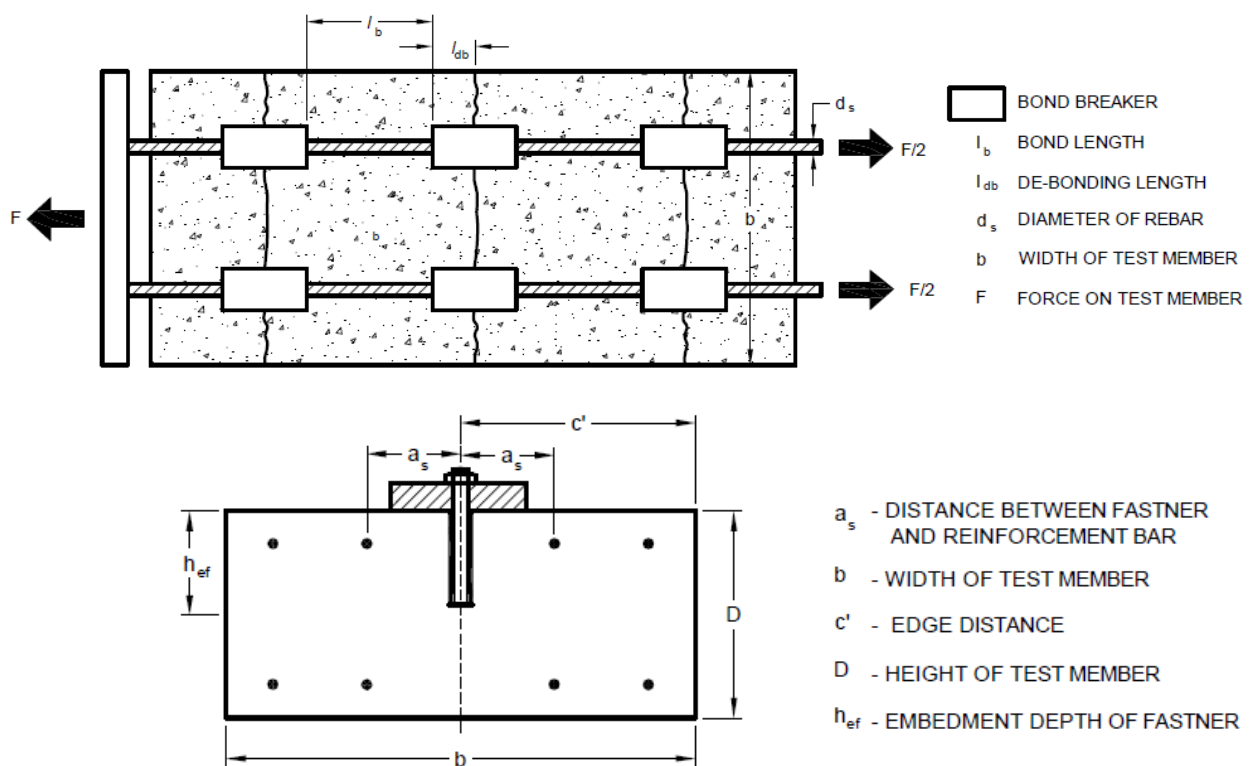

ELEVATION

10A TYPICAL CRACKED CONCRETE TEST MEMBER FOR CRACK CYCLING TEST

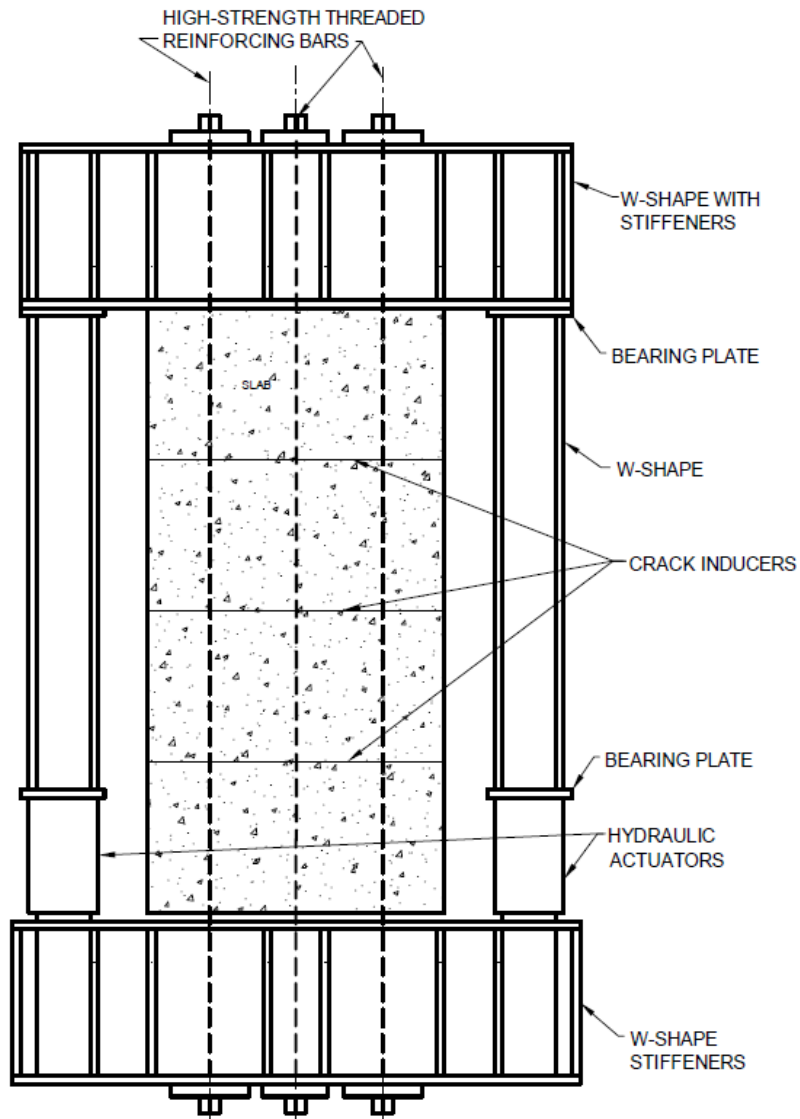

10 B TYPICAL TEST SET UP FOR CRACK CYCLING

FIG. 10 TYPICAL CRACKED CONCRETE TEST MEMBER AND TEST SET UP FOR CRACK CYCLING TEST

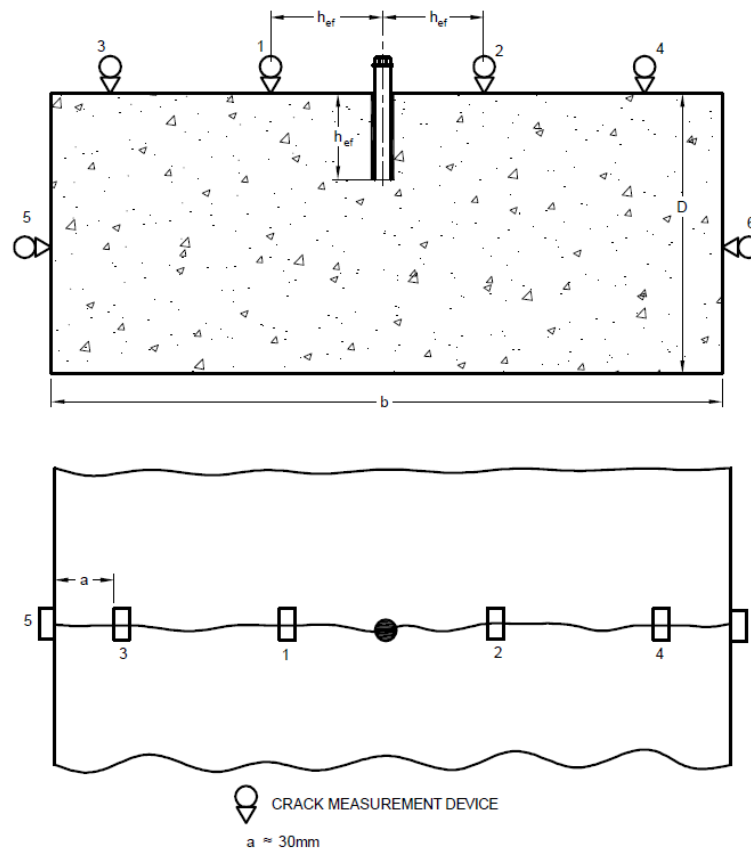

FIG. 11 ILLUSTRATION OF PLACEMENT OF CRACK MEASURING DEVICES TO VERIFY UNIFORM CRACK WIDTH

## 6.5 Anchor Specimen

### 6.5.1 Sampling and Selection of Test Specimen

The anchor samples including bolts, nuts and washers for test shall be selected such that they are representative of regular production of the manufacturer. If the mass production unit of the manufacturer is not established at the time of test, it shall be permitted to use specially manufactured samples, provided it is verified that the anchors subsequently produced conform to the anchors tested, in all respects. The fastening elements, such as screws to be used with internally threaded anchors for test shall be specified by the anchor manufacturer.

NOTE – It may be necessary to use fastening elements like bolts of higher strength than standard in some test series in order to achieve concrete cone failure. This shall be permitted if it does not influence the functioning of the anchor and is clearly documented in the test report.

### 6.5.2 Number of Test Specimen

Minimum of 5 samples per anchor diameter and embedment recommended by manufacturer shall be tested for each test series, unless otherwise noted in the test series (see Table 2).

### 6.5.3 Anchor variants for static tests

- a) The static tests shall be conducted with all types of fastening element and anchor diameters. In some test series, some reduction in anchor diameters to be tested is permitted (see Table 2).

NOTE - If the manufacturer applies for fastening element (such as, threaded rod) which are geometrically identical but of different material then all tests shall be performed with one material. For the other material, only the torque tests shall be carried out. If the fastening element has a reduced section along the length then shear tests for the evaluation of the characteristic shear strength shall be performed. In some cases, it shall be permitted to reduce the variants to be tested if it can be technically established that the performance will not change for the variant.

- b) For each test series, the recommended anchor diameters shall be tested at corresponding embedment in accordance with Table 2. The minimum embedment depth as recommended in Table 2 for unconfined tests shall be chosen in a way such that bond failure is decisive.

NOTE - In order to avoid steel failure in tests with maximum embedment and nominal embedment with capsule type adhesive anchors, the following procedure may be adopted. Stack the two concrete block on top of each other without any permanent connection between the two. Then drill and clean the hole as described in specific test series. Place the adhesive via capsule or injection technique. Remove the block on top and let the adhesive cure. After curing, perform confined test.

- c) If the manufacturer recommends more than one drilling technique, then tests shall be performed with all drilling techniques.

#### 6.5.4 Anchor variants for seismic tests

- a) All anchor diameter for which seismic qualification is sought shall be tested. All inserts or steel element types shall be tested.

NOTE – If the same bond strength is applicable to different type of fastening elements then the most adverse type shall be tested, and the results shall be used for other variants as well.

- b) The tests for seismic evaluation in tension shall be conducted with highest steel grade and lowest ductility for which the approval is sought for. In this case, the displacements measured for the variant that is tested shall be applied to other variants (that is, different steel types and steel grades) and drilling methods for which seismic qualification is sought.

NOTE – If corresponding reference tension tests was not performed for static evaluation then they shall also be conducted. Alternatively, it shall be permitted to calculate resistance from data obtained from tests in cracked concrete for static conditions.

- c) If the manufacturer recommends more than one drilling technique, then tests shall be performed with all drilling techniques.
- d) If the most brittle steel type is tested in shear, the assessment may be applied for the other steel types for which qualification is sought.
- e) If multiple embedment depths are recommended by manufacturer for an anchor diameter, it shall be permitted to test only embedment depth of  $7d_a$  in Test Series S1, S2, S4, and S6, to ensure bond failure. In this case, the reduction factors for seismic loading  $\alpha_N$  and  $\beta_{vF,N}$  determined for this embedment after assessment and the displacements measured shall be applied to other embedment depths as well.

NOTE – If steel failure occurs instead of bond failure at embedment depth then the tests shall be performed with fastening element of higher grade but identical geometry or the embedment depth itself may be reduced.

## 6.6 Installation of Anchor Specimen

**6.6.1** The anchor specimen for test should be installed in the formed face (that is, the side that has been cast against a form) of the concrete test member unless stated otherwise in the test series.

**6.6.2** The concrete test member shall be dry at time of anchor installation and testing, unless noted otherwise in test series.

NOTE – If different packaging of adhesive, nozzles, dispensers are recommended by manufacturer, equal mixing of adhesive shall be checked for all such variants prior to testing.

**6.6.3** The anchor specimen shall be placed at a spacing ( $s' > s'_{cr,N}$ ) and edge distance ( $c' > c'_{cr,N}$ ) higher than the critical value, unless otherwise noted in the test series. Critical spacing shall be taken as  $3h_{ef}$ . The critical edge distance  $c'_{cr,N}$  shall be taken as  $0.5s'_{cr,N}$ .

**6.6.4** The anchor samples shall be located from edge such that the test results are not influenced by the minimal reinforcement provided for handling.

**6.6.5** The anchor specimen shall be installed according to manufacturer's printed installation instruction (MPII), unless stated otherwise in the test series.

NOTE – The test method in this standard is not applicable to bulk type adhesives where mixing ratio is controlled by installer.

**6.6.6** The holes to be drilled for anchor installation shall be perpendicular to the surface of the concrete member; with maximum permissible deviation of  $\pm 5^\circ$ . The drilling should be performed in slab in floor direction. In the tests, the drilling tools including drill bit / core bit type specified by the manufacturer for the anchor specimen shall be used. The cutting diameter  $d_{cut}$  of drill bit shall be of medium tolerance range, unless stated otherwise in the test series. The cutting diameter of drill bit as a function of the nominal drill bit diameter is given in Fig. 12.

NOTE – The test method in this standard is only applicable to anchors installed in holes drilled using rotary hammer drill (by electric drilling machine or by compressed air) or diamond coring machine.

**6.6.7** The diameter of the drill bit shall be checked every 10 drilling operations to ensure continuous compliance.

**6.6.8** If use of special drill bits like stop-drills, hollow drill bits or diamond core drills is recommended by the anchor manufacturer for anchor installation then the anchor manufacturer shall specify the dimensions and tolerances of the bits, as no standards on the specification of these products are available. In this case, the tests shall be performed with drill bits within the specifications provided by manufacturer. The definition of a medium cutting diameter ( $d_{cut,m}$ ) for such cases should be laid down by the third party testing laboratories.

**6.6.9** For test in cracked concrete test member, the anchor specimen shall be placed in the middle of hairline cracks of the test member. The anchor shall be located in crack over the entire load transfer length.

NOTE – A borescope may be used to verify the crack prior to anchor installation.

**6.6.10** Adhesive anchors that do not require torque to activate the fastening mechanism shall be only finger tightened prior to testing, unless stated otherwise in the test series. For torque

controlled adhesive anchors, the torque moment shall be reduced to  $0.5T_{inst}$  after about 10 minutes of applying torque prior to testing, to account for relaxation of the prestressing force with time. The torque moments, when applicable, shall be applied to the anchor by a torque wrench. The measuring error shall not exceed 5 percent of the applied torque.

**6.6.11** For torque test, double-sided abrasive material shall be inserted between washer and fixture so that the washer does not turn w.r.t. the fixture while torquing.

**6.6.12** For internally threaded anchors, at least  $d_a + 5$  mm thread engagement of insert shall be required.

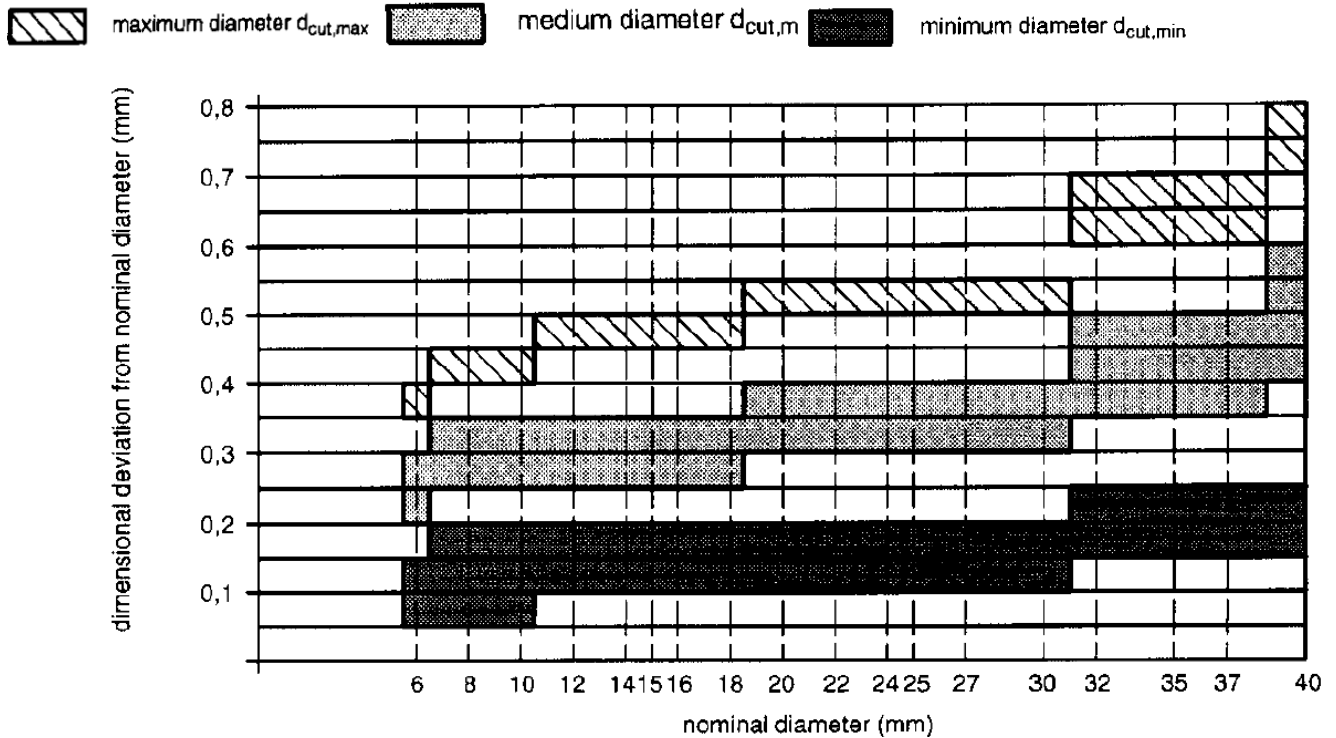

FIG. 12 TOLERANCE OF CUTTING DIAMETER OF HARD METAL HAMMER-DRILL BITS

**6.6.13** For Tests to assess Sensitivity to Reduced Cleaning Effort and Mixing Effort

Anchors shall be installed in standard uncracked concrete test member of same batch as the reference test that it is being compared to. For torque controlled adhesive anchors, the anchors shall be installed in standard cracked concrete. The anchor shall not be installed as per MPII. Instead, the installation procedure described for each test series in this section shall be followed. For installation, the holes shall be drilled with electric hammer drilling machine.

**6.6.13.1** Sensitivity to reduced cleaning in dry concrete

These tests shall be performed in dry concrete. As a preparation for installing the anchor, first the hole shall be drilled in downward direction to the depth specified by the manufacturer. Then, the hole shall be cleaned with cleaning tools and method specified prescribed in the MPII by the manufacturer but with half the effort required. For example, if the MPII specifies cleaning of hole with at least four blowing and two brushing operations then the hole should be cleaned using two blowing and one brushing operation in the order prescribed in the MPII.

If the MPII specifies less than this then the above requirement should be reduced proportionately, and the number of blows/ brushes should be lowered to the next whole number. For example, if the MPII recommends two blowing and one brushing operation then the suitability tests should be carried out without the brushing operation. If precise instructions for hole cleaning are not provided by the MPII, then the anchors shall be installed without hole cleaning. After hole cleaning the fastening element shall be installed in accordance with the MPII. If vacuum cleaning is recommended in the MPII instead of a blowing operation, the above procedure of reduced cleaning shall be applicable. If the vacuum cleaning is part of the drilling process, the drilling shall be done without venting during the drilling process. If the cleaning is performed with a suction bit or a hollow drill bit, then the vacuum with the smallest specified maximum flow rate shall be used during the drilling process.

#### **6.6.13.2** *Sensitivity to reduced cleaning in water saturated concrete*

For these tests, the concrete in the area of anchorage shall be water saturated when the hole is drilled, cleaned and the embedded part is installed. To ensure water saturation in concrete in the anchorage area, first a hole with half the hole diameter of anchor to be tested shall be drilled in the concrete substrate to the recommended depth. The hole shall be then filled with water and shall remain flooded for 8 days until water has percolated into the concrete at a distance equal to 1.5 to 2 times the anchor diameter from the axis of the hole. Water shall be then sucked out of the hole and the hole shall drilled at the recommended diameter  $d_0$ . The hole cleaning and installation shall be done according to **6.6.13.1**.

NOTE - If methods other than those described above for water saturation of concrete are used then it shall be shown by appropriate methods that the concrete in the anchorage area is water saturated.

#### **6.6.13.3** *Sensitivity to reduced cleaning in water filled holes*

For these tests, concrete in the area of anchorage shall be water saturated when the hole is drilled and cleaned. To ensure that concrete is water saturated in anchorage area, the procedure of **6.6.13.2** shall be applied. After cleaning the hole with reduced effort according to **6.6.13.1**, the hole shall be filled with water. Without removing water from the hole, the adhesive material shall be injected, and the embedded part shall be inserted as described in the MPII.

NOTE - This test shall not be required for anchors where the MPII states that water should be completely removed before anchor installation.

#### **6.6.13.4** *Sensitivity to mixing technique*

In this test series, the tests shall be carried out on incomplete mixes, that is, by reducing the specified process by 25 percent. For example, if the manufacturer recommends mixing until color change of adhesive then the test should be carried out after mixing for 75 percent of the time taken to achieve an even color throughout the material.

NOTE - These tests shall only be required for those anchor types where the mixing technique is controlled by the installer, for example: Mixing adhesive components until a color change is affected throughout the material, Mixing with recommended equipment for a specified time, Carrying out a repetitive mixing operation for a specified number of times etc. These tests shall not be required for capsule and injection type anchors.



#### **6.6.14 For Tests to assess Sensitivity to Reduced Installation Torque**

To determine the sensitivity of torque controlled adhesive anchors to reduced torque moment, the anchors shall be installed in standard cracked concrete test member of same batch. The anchor shall be installed as per MPlI. However only 50 percent of the installation torque shall be applied.

### **7 TEST CONDITIONS AND PROCEDURE**

#### **7.1 General Test Conditions**

**7.1.1 Test and Assessment Options** – Seismic (Option A), Cracked concrete assessment (Option B) and Uncracked concrete assessment (Option C) are covered by this standard. Test regime in Table 2 shall apply for the selected assessment option. For Seismic Option, qualification for use in cracked concrete is a prerequisite.

**7.1.2 Test specimen** – Anchors shall be installed as per MPlI, unless stated otherwise in the test series, in concrete test member of specified concrete strength and cracked conditions defined for the test series.

**7.1.3 Temperature** – The tests shall be performed at ambient temperature of  $23 \pm 5$  °C, unless stated otherwise in the test series.

**7.1.4 Loading Rate** – The rate of loading shall be controlled such that the peak load occurs after 1 to 3 minutes from commencement of test.

**7.1.5 Load and Displacement Measurement Frequency** – The load and displacement data shall be recorded either continuously or at least in about 100 intervals or data points. Load, displacement, or hydraulic control shall be used for test. In case of displacement control, the test should be continued up to at least 75% of the maximum load expected to allow the drop of the load-displacement curve for recording purpose.

**7.1.6 Displacement Measurement in Tension Tests** – The displacements of the anchor relative to the concrete surface shall be measured by use of either one displacement transducer on the head of the anchor or at least two displacement transducers on either side placed at a distance of greater than or equal to  $1.5h_{ef}$  from the anchor; the average value shall be recorded in the latter case.

**7.1.7 Displacement Measurement in Shear Tests** – The displacements of the anchor relative to the concrete shall be measured in the direction of the load application. This may be accomplished by use of a displacement transducer fixed behind the anchor, seen from the direction of load application, on the concrete.

#### **7.1.8 Crack width measurement**

The average of measured crack width for each test series for each anchor shall be equal to or greater than the specified crack width for the test series. The individual crack width achieved shall be within the following tolerance:

- a) 20 percent of crack width specified for the test series for  $\Delta w < 0.3$  mm
- b) 10 percent of crack width specified (but not more than 0.04 mm) for the test series for  $\Delta w \geq 0.3$  mm

The average of crack width of a test series, however, shall reflect the required value. The crack width shall be controlled while the anchor is subjected to load, either:

- a) At a constant width, for example, by means of a servo system, or
- b) Limited to a width close to the specified value by means of appropriate reinforcement and depth of the test member.

Use only one sided tolerance for crack width.

Irrespective of the method used, the crack width at the face opposite to that in which the anchor is installed should be maintained close to the specified value.

In case of static tension test, the crack widths shall be measured at a distance of approximately  $h_{ef}$  from anchor (or as close as possible but not at a distance greater than 150 mm from the anchor) and at least on the face of the test member in which the anchors are installed.

In case of static shear test, the crack widths shall be measured at a distance of approximately  $h_{ef}$  behind the anchor (seen from the direction of load application) and the load shall be applied in the direction of the crack towards the edge.

For pulsating tension tests, the crack width shall be measured using devices placed at locations as illustrated in Fig. 11.

For alternating shear tests, the crack width shall be measured within a distance of  $h_{ef}$  in front & behind the anchor or directly on anchor location, if possible.

## 7.2 Steel Capacity Test

This test is performed to determine the characteristic resistance to steel failure. This test may be omitted in case the steel strength of the product can be determined easily (constant diameter and constant steel strength).

**7.2.1** For anchors installed in concrete, steel capacity test shall be conducted with a confined/unconfined test set up (as applicable based on the type of anchor) in high strength concrete.

**7.2.2** Alternatively, this test should be performed on finished anchor product to determine characteristic resistance to steel failure. Universal testing machine should be used to determine the steel capacity of the anchor. Special fixtures may be required to hold the anchor in position for testing. The load and elongation percentage (if applicable) shall be recorded.

## 7.3 Maximum Installation Torque Moment Test

This test is performed to verify that the application of installation torque will not result in steel failure of the bolt. Torque test set up according to **5.8** shall be used. The installed anchor specimen shall be torqued with a calibrated torque wrench until torque cannot be increased further or at least to  $1.3T_{inst}$ . The tension force in the bolt shall be measured as a function of the applied torque moment. The connection should be unscrewed at the end of the test to check if it is possible to remove the nut.

## 7.4 Unconfined Tension test

This test is performed to determine pull-out strength in unconfined set up. After the anchor is installed, it shall be connected to the loading device and pulled in tension to failure using unconfined tension test set up as per **5.4**. In case of tests in cracked concrete, the cracks shall

be opened to specified crack width after anchor installation, prior to testing. These tests shall be carried out with same diameter and in the same slab or at least the same concrete batch as the corresponding tests for resistance to pull-out failure. The load displacement behavior and variation shall be recorded.

The basic reference tension tests to determine characteristic resistance of post installed adhesive anchors, without influence of edge distance and spacing, (Test Series 11 to 14) are performed in an unconfined set-up.

**7.4.1** For “Critical edge distance test to prevent splitting under load”, the unconfined tension test setup shall be placed such that an unrestricted concrete failure towards the edge is possible. As the anchor is located in corner in this test, the test setup should be supported outside the test member (see Fig. 13).

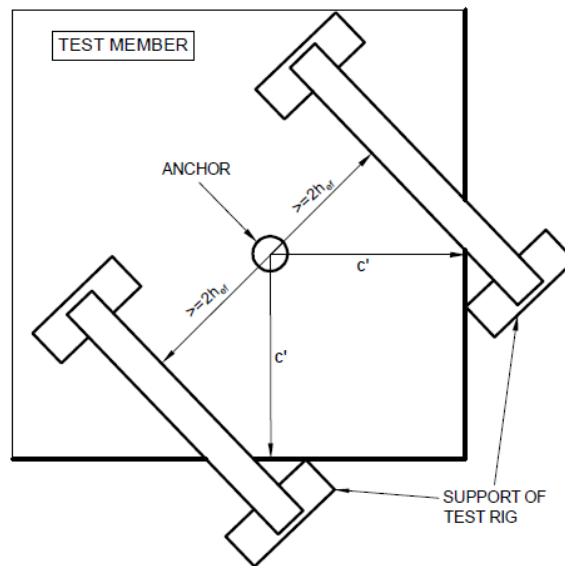

FIG. 13 EXAMPLE OF TENSION TEST SETUP FOR CORNER TEST FIGURE NEEDS TO BE REDRAWN)

**7.4.2** For unconfined tension test to determine minimum embedment depth, group of 4 anchors installed at lesser embedment depth than minimum in standard uncracked concrete test members in accordance with 6.2 with spacing equal to  $s'_{cr,N}$ .

NOTE – This test may be omitted if the embedment depth is in accordance with values mentioned in 5.2.2 of CED 02(25733).

#### 7.4.3 Slip Force Test

The purpose of this test is to determine the force at which the adhesion between the anchor rod and the adhesive is lost for a torque controlled adhesive anchor. For this test, anchors shall be installed in standard cracked concrete test member of same batch in accordance with 6.3. The anchor shall be installed as per MPII however no installation torque shall be applied. Inductive load displacement transducer shall be installed at the unloaded end of the anchor rod. After the anchor is installed, it shall be connected to the loading device. The cracks shall be opened to 0.3 mm and pulled in tension to failure in an unconfined test set-up. The mean slip force and relative displacement of the anchor rod with respect to the concrete shall be measured.

#### 7.4.4 Bond Force Test

This test is performed to determine the force at which the adhesion between the adhesive and the drill hole surface is lost for a torque controlled adhesive anchor. For this test, anchors shall be installed in standard strength cracked concrete test member of same batch in accordance with 6.3. A normal threaded rod of comparable length and diameter is used, which does not generate any expansion force. No installation torque shall be applied. Hole cleaning is carried out according to 6.6.13.1. Inductive load displacement transducer shall be installed at the unloaded end of the anchor rod. After the anchor is installed, it shall be connected to the loading device. The cracks shall be opened to 0.3 mm and pulled in tension to failure in an unconfined test set-up.

NOTE – If the slip force test and bond force tests are carried out for torque controlled adhesive anchors and assessment carried out as per 8.2.2, the number of tests given in Table 2 may be performed with reduced sample size. In case the slip force and bond force tests are not performed, the sample size shall be as per Table 2.

**7.4.5** Unconfined test shall be performed to assess performance to sensitivity of post installed torque controlled adhesive anchors under the following conditions –

1. Reduced cleaning in dry concrete (Test Series 24)
2. Reduced cleaning in water saturated concrete (Test Series 25)
3. Reduced cleaning in water filled holes (Test Series 26)
4. Mixing technique (Test Series 27)
5. Sensitivity to reduced installation torque (Test Series 38)

**7.4.6** Unconfined tension test shall be performed for torque controlled adhesive anchors for reference tension tests in standard strength cracked concrete with large crack width ( $\Delta w = 0.8$  mm) (Test Series S1) and reference tension tests in high strength cracked concrete with large crack width ( $\Delta w = 0.8$  mm) (Test Series S2) without edge and spacing influence for seismic evaluation.

#### 7.5 Confined tension test

This test is performed to determine pull-out (bond) strength in a confined set-up. After the anchor is installed, it shall be connected to the loading device and pulled in tension to failure using confined tension test set up as per 5.5. In case of tests in cracked concrete, the cracks shall be opened to specified crack width after anchor installation, prior to testing. These tests shall be carried out with same diameter and in the same slab or at least the same concrete batch as the corresponding tests for resistance to pull-out failure. The load displacement behavior and variation shall be recorded.

The basic reference tension tests to determine characteristic resistance of post installed adhesive anchors (Test Series 3 to 6) are performed in a confined set-up.

**7.5.1** In addition, the following tension tests are conducted in a confined test set-up –

- a) Test Series 7 – Basic tension test for sensitivity to cleaning.
- b) Test Series 8 – Basic tension test for sustained load (at ambient temperature at maximum long term temperature and at minimum installation temperature  $< 0^{\circ}\text{C}$ )
- c) Test Series 9 – Basic tension test for freeze-thaw

**7.5.2** Confined test shall be performed to assess performance to sensitivity of post installed adhesive anchors under the following conditions –

- a) Reduced cleaning in dry concrete (Test Series 24)
- b) Reduced cleaning in water saturated concrete (Test Series 25)
- c) Reduced cleaning in water filled holes (Test Series 26)
- d) Mixing technique (Test Series 27)

**7.5.3** Confined tension test shall be performed for adhesive anchors for reference tension tests in standard strength cracked concrete with large crack width ( $\Delta w = 0.8$  mm) (Test Series S1) and reference tension tests in high strength cracked concrete with large crack width ( $\Delta w = 0.8$  mm) (Test Series S2) without edge and spacing influence for seismic evaluation.

### **7.6 Minimum Edge Distance and Spacing test**

This test is performed to check that splitting of base material does not occur during the installation of anchor at minimum edge and spacing values recommended by manufacturer.

**7.6.1** An anchor group of two anchor with minimum spacing ( $s' = s'_{min}$ ) is installed at minimum edge distance ( $c' = c'_{min}$ ) shall be installed in uncracked concrete member as per **6.2**. The double anchors are placed on an uncast side of a concrete test member with a distance  $\geq 3h_{ef}$  between neighboring groups. In total, 5 such anchor groups shall be tested.

**7.6.2** If it is necessary to provide edge reinforcement, it shall be permissible to do so, provided this edge reinforcement is stated in the test report and assessment document as a minimum requirement.

**7.6.3** The diameter  $d_{fix}$  of the clearance holes in the fixture shall correspond to the values given in Table 1. The fixture shall be  $3d_{fix}$  in width,  $s_{min} + 3d_{fix}$  in length and  $d_{fix}$  in thickness.

NOTE – The edge distance and spacing shall be rounded to at least 5 mm and should not be less than maximum of  $4d_0$  and 35 mm. If cracks appear during setting then the edge and spacing shall be increased and the test shall be repeated.

**7.6.4** Calibrated torque wrench shall be used to perform this test. The anchors in the anchor group shall be torqued alternately in steps of  $0.2 T_{inst}$ , where  $T_{inst}$  is the installation torque. After each load step, the concrete surface shall be inspected for cracks. The test shall be stopped when the torque moment cannot be increased further. The number of revolutions per load step shall be measured for both anchors.

**7.6.5** The torque moment at the formation of the first hairline crack at one or both anchors and the maximum torque moment that can be applied to the two anchors shall be recorded.

### **7.7 Tests to Determine Influence of Increase in Temperature on Characteristic Strength at Maximum Long Term and Short Term Temperature**

These tests are performed to determine the influence of increase in temperature on characteristic resistance of an adhesive anchor, simulating service conditions that vary within the considered temperature range.

**7.7.1** For this test, anchors shall be installed in standard uncracked concrete test member of same batch in accordance with **6.2**. Alternatively, the tests may be conducted in cube of side length 200 mm to 300 mm ( $15d_a$  to  $25d_a$ ) or steel encased concrete cylinder. The splitting of concrete test cube shall be prevented by confining it. At least 5 samples should be tested per temperature.

**7.7.2** The concrete test member shall be conditioned in temperature controlled (for heating) chambers. Confined tension test in accordance with **7.5** shall be performed.

**7.7.3** The anchor shall be installed at ambient temperature. After curing of specimen, the temperature of test member shall be then raised to required test temperature at a rate of approximately 20°C per hour to achieve temperature recommended in the test series. The test specimen shall be allowed to condition at this temperature for 24 hours. After the conditioning period of 24 hours, confined tension test shall be carried out to failure while maintaining the temperature of the test member in the area of the embedded part at a distance of  $d$  from the concrete surface at  $\pm 2^\circ\text{C}$  of the required value.

**7.7.4** The tests shall be carried out at the following temperatures for maximum long term temperature and maximum short term temperature for the different temperature ranges:

- a) *Temperature range T1* — Maximum short term temperature up to + 40°C: Tests shall be performed with maximum short term temperature at +40°C. The maximum long term temperature at approximately +24°C shall be checked by the tests at ambient temperature.
- b) *Temperature range T2* — Maximum short term temperature up to + 80°C: Tests shall be performed with maximum short term temperature at +80°C and with maximum long term temperature at +50°C.
- c) *Temperature range T3* — as requested by manufacturers: Tests shall be performed with maximum short term temperature and maximum long term temperature specified by the manufacturer within the range of 0.6 times to 1.0 times maximum short term temperature; with maximum short term temperature > 40°C.

#### NOTES

**1** The check to ensure that the requirement on the temperature in the test member is fulfilled should be done once and then the temperature for the test procedure should be kept constant.

**2** For behavior under fire, further testing and assessment is required which is beyond the scope of this standard.

### **7.8 Tests to Determine Effectiveness of Minimum Curing Time at Minimum and Ambient Installation Temperature**

These tests are performed to determine whether the anchor is able to develop its strength when set for minimum curing time at minimum and ambient temperature.

**7.8.1** For this test, anchors shall be installed in standard uncracked concrete test member of same batch in accordance with **6.2**. Alternatively, the tests may be conducted in cube of side length 200 mm to 300 mm ( $15d_a$  to  $25d_a$ ) or steel encased concrete cylinder. The splitting of concrete test cube shall be prevented by confining it. The curing time shall be same as corresponding reference test. The concrete test member shall be conditioned in temperature controlled (for cooling and heating) chambers. Confined tension test in accordance with **7.5** shall be performed. The test specimen should be conditioned and tested as per **7.8.2** for minimum installation temperature and **7.8.3** for ambient temperature.

### 7.8.2 Minimum Curing Time at Minimum Installation Temperature

After cleaning, the temperature of test member shall be lowered to required test temperature. The adhesive and the fastening element shall be cooled to the lowest anchor component installation temperature specified by the manufacturer. The conditioning period of 24 hours shall be observed. The anchor shall be installed, and the temperature of the test member shall be maintained at the lowest installation temperature for the minimum curing time provided by the manufacturer at that temperature. After curing, tension test shall be carried out to failure while maintaining the temperature of the test member in the area of the embedded part at a distance of  $d$  from the concrete surface at  $\pm 2^\circ\text{C}$  of the required value.

### 7.8.3 Minimum Curing Time at Ambient Temperature

The anchors shall be installed at ambient temperature. Minimum curing time recommended by manufacturer at that temperature shall be observed. After curing, confined tension test shall be carried out to failure at ambient temperature. This test shall be repeated with longer curing time. The "longer curing time" is the maximum curing time normally used in reference tests (24 hours for resins, 14 days for cementitious mortars).

## 7.9 Repeated load test

This test is performed to determine influence of repeated load on anchor behavior which simulate service loads that are subject to variation over time.

**7.9.1** After anchor installation, the anchor shall be subjected to  $10^5$  load cycles (assessment for 50 years' service life) or  $2 \times 10^5$  load cycles (assessment for 100 years working life), as applicable, with a maximum frequency of 6 Hz approx.

**7.9.2** During each load cycle, the tensile load applied on anchor shall change as a sine curve between  $N_{max}$  and  $N_{min}$  determined according to the equations given below:

$$N_{max} = \frac{1.1 \tau_{Rk,uncr'} \pi d_a h_{ef}}{1.5 \gamma_{inst}} \frac{1}{\alpha_2} \frac{1}{\alpha_3} \frac{1}{\alpha_4}$$

$$N_{min} = \text{maximum of } 0.25 (\tau_{Rk,uncr'} \pi d_a h_{ef}) \text{ and } (N_{max} - A_s \cdot \Delta \sigma_s)$$

where

$\tau_{Rk,uncr'}$  = Characteristic bond strength in standard uncracked concrete from all confined tension tests in uncracked concrete (corresponding to ambient temperature)

NOTE - Based on performance in other tension tests the expected characteristic bond strength for this test shall be estimated and included in determination of  $\tau_{Rk,uncr'}$  [that is, the value expected to be eventually published in AR].

$A_s$  = Stressed anchor cross-section

$\Delta \sigma_s$  = 120 N/mm<sup>2</sup>

$\gamma_{inst}$  = partial safety factor taking account of the installation safety of an anchor system

$\alpha_2$  = Factor determined after assessment of tests at maximum long term temperature

$\leq 1.0$

$\alpha_3$  = Factor determined after assessment of tests at maximum short term temperature

$$\leq 1.0$$

$\alpha_4$  = Ratio determined after assessment of tests to check sensitivity to high alkalinity

and sulphurous environment  $\leq 1.0$

**7.9.3** The displacements shall be measured during the first loading up to  $N_{max}$  and then either continuously or at least after 1, 10,  $10^2$ ,  $10^3$ ,  $10^4$  and  $10^5$  (or  $2 \times 10^5$ ) of repeated load cycles, as applicable.

**7.9.4** At the end of the load cycle, the anchor shall be unloaded, and the displacement shall be measured. A tension test (i.e., residual load test) to failure shall be performed in a confined test set-up after completion of the load cycle in accordance with **7.5**.

### 7.10 Sustained load test

This test is performed to check the creep behavior of a loaded anchor at normal ambient temperature and at maximum long term temperature without edge and spacing influence.

**7.10.1** The anchors shall be installed in standard uncracked concrete test member of same batch in accordance with **6.2**. The test member and test specimen shall be conditioned in temperature controlled chamber or equipment (oven or freezer) as per requirement of test series. The sustained load should be applied using a hydraulic jack, springs or deadloads applied via a lever arm. The minimum duration of application of sustained load in the test shall be three months for an assessment of 50 years of service life and six months for an assessment of 100 years of service life. The test specimen should be conditioned and tested as per **7.10.2** for ambient temperature and **7.10.3** for maximum long term temperature. The frequency of monitoring displacements during the sustained load period shall be chosen so as to demonstrate the characteristics of the anchor. As displacements are greatest in the early stages, the frequency should be high initially and reduced with time. As an example, the displacement should be measured every 10 minutes during first hour, every hour during the next 6 hours, every day for next 10 days and every 5-10 days from then on. The load displacement behavior and coefficient of variation shall be recorded for the residual load test.

#### 7.10.2 Sustained Load at Ambient Temperature

Anchors shall be installed at ambient temperature. Anchor shall be loaded to  $N_{sus}$  given by

$$N_{sus} = \frac{1.1 (\tau_{Rk,uncr'} \pi d_a h_{ef})}{1.5 \gamma_{inst}} \frac{1}{\alpha_2} \frac{1}{\alpha_3} \frac{1}{\alpha_4}$$

For torque controlled adhesive anchors,  $N_{sus} = \frac{1.1 \cdot N_{Rk,uncr'}}{1.5 \gamma_{inst}} \frac{1}{\alpha_2} \frac{1}{\alpha_3} \frac{1}{\alpha_4}$

$\tau_{Rk,uncr'}$  = Characteristic bond strength in standard uncracked concrete from all confined tension tests in uncracked concrete (corresponding to normal ambient temperature)

$N_{Rk,uncr'}$  = Characteristic pull-out resistance of a torque controlled adhesive anchor in standard uncracked concrete from all unconfined tension tests in uncracked concrete (corresponding to normal ambient temperature).



The load  $N_{sus}$  shall be maintained at ambient temperature (maximum variation of 5 percent). The displacements shall be measured until they appear to have stabilized. The minimum length of this test shall be at least three months or six months depending on the assessment for service life. The test room temperature shall be allowed to vary by  $\pm 3^{\circ}\text{C}$  but the required test room temperature shall be achieved as an average over the test period. To check the residual load capacity after the sustained load test, the anchor shall be unloaded, and a confined tension test shall be carried out at the ambient temperature in accordance with **7.5**.

### 7.10.3 Sustained Load at Maximum Long Term Temperature

Sustained load tests at maximum long term temperature shall be performed in concrete specimen made from the same batch as used for the tests according to **7.10.2**. Anchors shall be installed at standard ambient temperature. Anchor shall be loaded to  $N_{sus}$  given by

$$N_{sus} = \frac{1.1 \tau'_{Rk,uncr',mlt} \pi d_a h_{ef}}{1.5 \gamma_{inst}} \frac{1}{\alpha_3} \frac{1}{\alpha_4}$$

For torque controlled adhesive anchors,  $N_{sus} = \frac{1.1 \cdot N'_{Rk,uncr',mlt}}{1.5 \gamma_{inst}} \frac{1}{\alpha_3} \frac{1}{\alpha_4}$

where,

$\tau'_{Rk,uncr',mlt}$  = Characteristic bond strength in standard uncracked concrete from all confined tension tests in uncracked concrete (corresponding to maximum long term temperature)

$N'_{Rk,uncr',mlt}$  = Characteristic pull-out resistance of a torque controlled adhesive anchor in standard uncracked concrete from all unconfined tension tests in uncracked concrete (corresponding to maximum long term temperature).

The temperature of the test chamber shall be raised to the maximum long term temperature at a rate of approximately  $5^{\circ}\text{C}$  per hour. The load  $N_{sus}$  and maximum long term temperature shall be maintained. The displacements shall be measured until they appear to have stabilized. The minimum length of this test shall be at least three months or six months, as applicable. The test room temperature shall be allowed to vary by  $\pm 3^{\circ}\text{C}$  but the required test room temperature shall be achieved as an average over the test period. To check the residual load capacity after the sustained load test, the anchor shall be unloaded, and a confined tension test shall be carried out at the maximum long term temperature in accordance with **7.5**.

NOTE - It shall not be required to perform these tests for temperature range T1 as defined in 7.7.4 as the effect of the maximum long term temperature ( $+24^{\circ}\text{C}$ ) is tested under standard test temperature.

### 7.11 Slice Test

This test is performed to evaluate sensitivity of adhesives to different environmental exposures. Temperature control chamber or equipment and punch test set up shall be used. Test specimen should be prepared as described in this section. After the storage time in respective test series, the thickness of the slices shall be measured. The peak load in punch test shall be recorded.

**7.11.1** For this test, anchors shall be installed in standard uncracked concrete test member in accordance with **6.2**. Concrete of low compressive strength class shall be used to prepare cylindrical specimens of diameter  $\geq 150$  mm or cubes of side length  $\geq 150$  mm. The concrete test specimens shall be cast, or diamond cored from slabs. Only one anchor shall be installed on the central axis of each concrete cylinder or cube. The anchorage element shall be made of stainless steel. After curing of the adhesive according to MPII, the test specimens shall be carefully sawn into 30 mm thick slices with a diamond saw. The top slice shall be discarded. A minimum of 30 slices shall be prepared, 10 slices for every environmental exposure tests and 10 slices for the comparison tests under standard conditions.

#### **7.11.2** *Reference Slice Test*

The slices shall be stored under standard conditions (dry /  $23^{\circ}\text{C} \pm 5^{\circ}\text{C}$  / relative humidity  $50 \pm 5$  percent) for 2000 hours. After storage period, the punch test shall be carried out on the test specimen.

#### **7.11.3** *Sensitivity to High Alkalinity*

The slices shall be stored under standard conditions in a container filled with an alkaline fluid (pH = 13.2). All slices shall be completely covered for 2000 hours. The alkaline fluid should be produced by mixing water with KOH (potassium hydroxide) powder or tablets until the pH-value of 13.2 is reached. The alkalinity of pH = 13.2 should be kept as close as possible to 13.2 during the storage and should not be allowed to fall below a value of 13.0. The pH-value shall be checked and monitored at regular intervals, at least once every day. After storage period, the punch test shall be carried out on the test specimen.

NOTE - If other materials are used to prepare alkaline fluid then it should be shown that similar results and comparable assessment are achievable.

#### **7.11.4** *Sensitivity to Sulphurous Atmosphere*

The slices with adhesive anchors shall be subjected to condensed water with sulphurous atmosphere. The slices shall be put into the test chamber; the theoretical Sulphur dioxide concentration shall be 0.67 percent at beginning of a cycle. This theoretical Sulphur dioxide concentration corresponds to  $2 \text{ dm}^3$  of  $\text{SO}_2$  for a test chamber volume of  $300 \text{ dm}^3$ . At least 80 cycles shall be carried out. After storage period, the punch test shall be carried out on the test specimen.

NOTE – Specialist literature may be referred to for this test.

#### **7.11.5** *Punch Test*

Within 24 hours after removal of the specimen from storage, the thickness of the slices shall be measured. The slice shall be then placed centrally to the hole of the steel rig plate for punch test. The test apparatus shall permit the metal part, that is, the anchor element of the slice, to be punched through the slice while restraining the surrounding concrete (see **5.9**). The loading punch shall act centrally on the metal element. The peak load for each test shall be recorded.

NOTE – If slices are unreinforced then splitting may be prevented by confinement. Care shall be taken to ensure that the loading punch acts centrally on the anchor rod. Results with splitting failure shall be ignored.

## 7.12 Installation at freezing temperature

This test is performed to determine the performance of an adhesive anchor when installed and cured under freezing condition. For this test, anchors shall be installed in standard uncracked concrete test member in accordance with **6.2**. The concrete test member shall be conditioned in temperature controlled chambers. The minimum installation temperature shall be as per the respective AR of the adhesive anchor. Prior to commissioning of the test, the steel element (that is, the threaded rod) and the concrete test member shall be maintained at the minimum installation temperature as per the MPII for a period of 24 hours. The adhesive shall also be lowered to the same temperature as per the MPII. The adhesive anchors shall be installed and allowed to be cured at the minimum installation temperature. Sustained load corresponding to **7.10** shall be applied. The temperature of the test chamber shall be gradually raised to standard value over a period of 72 to 96 hours. Once the ambient temperature is attained and displacement of the anchors are stabilized, confined tension test to failure shall be conducted on the samples in accordance with **7.5**. In case the displacements do not stabilize in 150 hours from the commencement of temperature rise, the test has to be repeated with appropriate modifications.

NOTE – This test may be omitted if the MPII specifies installation in concrete above 0°C only.

If the manufacturer allows temperature variation within a 12 hour period from 0°C or less to 24°C or more, the test shall be carried out considering this rapid variation of temperature. Prior to commissioning of the test, the steel element (that is, the threaded rod) and the concrete test member shall be maintained at the minimum installation temperature as per the MPII for a period of 24 hours. The adhesive shall be cooled to the lowest installation temperature as specified in the MPII. The adhesive anchors shall be installed and allowed to be cured at the minimum installation temperature. Immediately after the curing period has elapsed, the test member shall be removed from the cooling chamber and the anchor shall be subjected to a tension preload not exceeding 5 percent of the sustained load corresponding to **7.10** or 1.5 KN, prior to making the displacement reading as zero. The load on the anchor shall be increased to the sustained load corresponding to **7.10** and the temperature of the test chamber shall be gradually raised to ambient value at the rate of 5°C/hr. The sustained load shall be maintained (with allowable variation of 5 percent) over a duration of minimum 42 days while the displacement of the anchor is monitored. The monitoring shall be done in every 10 minutes over the first hour, hourly basis during the next 6 hours, daily over the next 10 days and in every 5-10 days interval for the rest of the time.

NOTE – In case the displacements do not stabilize, the test has to be repeated with appropriate modifications.

## 7.13 Crack Cycling Test

This test is performed to ensure effective functioning of anchor in sustained tension in cracked concrete when width of crack is fluctuating in the range covered by this standard. For this test, anchors shall be installed in standard cracked concrete test member in accordance with **6.3**. The initial crack width should be 0.3 mm. Unconfined test set-up shall be used for torque controlled adhesive anchors in accordance with **5.4** and confined set-up shall be used for adhesive anchors in accordance with **5.5**. The unconfined test shall be performed as per **7.4** and confined test shall be performed as per **7.5**.

**7.13.1** In the test, the anchor shall be subject to crack width fluctuations within a defined range. The maximum load (max  $N_{TM}$ ) and minimum load (min  $N_{TM}$ ) for load cycle to be applied to the test member after anchor installation, shall be determined such that the crack width under max  $N_{TM}$  is  $\Delta w_1 = 0.3$  mm and under min  $N_{TM}$  is  $\Delta w_2 = 0.1$  mm.

**7.13.2** Up to 10 load cycles varying between max  $N_{TM}$  and min  $N_{TM}$  shall be applied to the test member to stabilize crack formation. Then a tensile load  $N_{sus}$  determined according to the following equation shall be applied to the anchor in an unconfined set-up after opening the crack to  $\Delta w_1 = 0.3$  mm.  $N_{sus}$  shall remain constant during the test with a tolerance of  $\pm 5\%$ .

$$N_{sus} = \frac{0.75\tau_{Rk,cr'}\pi d_a h_{ef}}{1.5\gamma_{inst}} \frac{1}{\alpha_2} \frac{1}{\alpha_3} \frac{1}{\alpha_4}$$

where

$\tau_{Rk,cr'}$  = Characteristic bond strength in standard cracked concrete from all confined tension tests in cracked concrete (corresponding to ambient temperature)

NOTE – Based on performance in other tension tests the expected characteristic bond strength for this test shall be estimated and included in determination of  $\tau_{Rk,cr'}$  (that is, the value expected to be eventually published in AR).

For torque controlled adhesive anchor,

$$N_{sus} = \frac{0.75 \cdot N_{Rk,cr'}}{1.5\gamma_{inst}} \frac{1}{\alpha_2} \frac{1}{\alpha_3} \frac{1}{\alpha_4}$$

$N_{Rk,cr'}$  = Characteristic pull-out resistance of a torque controlled adhesive anchor in standard cracked concrete from all unconfined tension tests in cracked concrete (corresponding to ambient temperature)

**7.13.3** After  $N_{sus}$  is applied, the crack shall be opened and closed 1000 times at frequency of approximately 0.2 Hz for evaluation of 50 years working life. For 100 year service life assessment, the number of crack cycling shall be 2000, other parameters remaining same.

**7.13.4** During opening of the cracks, the crack width  $\Delta w_1$  shall be kept approximately constant (see Fig. 14); for this purpose the max  $N_{TM}$  load applied to the test member may have to be reduced. The min  $N_s$  load shall be kept constant.

NOTE – As min  $N_{TM}$  load is kept constant the crack width  $\Delta w_2$  may increase during the test.

**7.13.5** The difference in crack width  $\Delta w_1 - \Delta w_2$ , shall be maintained at least  $\geq 0.1$  mm during the crack cycling. If this condition cannot be satisfied with  $\Delta w_1 = 0.3$  mm, then either min  $N_s$  should be reduced or  $\Delta w_1$  should be increased accordingly.

**7.13.6** The load-displacement behavior shall be measured up to the load  $N_{sus}$ . Afterwards under constant load  $N_{sus}$ , the displacement of the anchor and the crack widths  $\Delta w_1$  and  $\Delta w_2$  shall be measured either continuously or at least after 1, 2, 5, 10, 20, 50, 100, 200, 500 and 1000/ 2000 crack cycles.

**7.13.7** The anchor shall be unloaded, the displacement shall be measured and a tension test to failure shall be conducted using confined tension test set as per **7.5** up with  $\Delta w = 0.3$  mm, after completion of the crack cycling.

NOTE – In case an adhesive anchor is already tested for 50 years service life, only the three smallest diameters must be tested for 100 years service life.

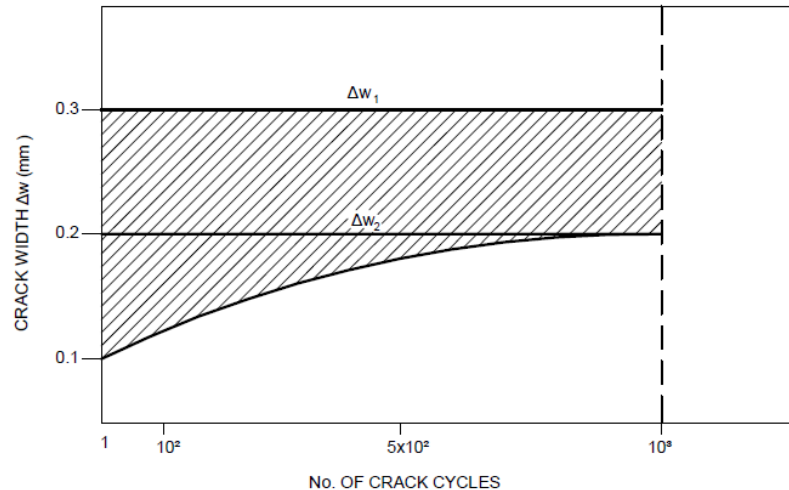

FIG. 14 ALLOWABLE CRACK OPENING VARIATIONS DURING THE CRACK CYCLING TEST

#### 7.14 Sensitivity to Freeze/Thaw

This test is performed to determine sensitivity of anchor to freeze/thaw.

**7.14.1** For this test, anchors shall be installed in high strength uncracked concrete test cube in accordance with **6.2**. The concrete member used shall be freeze thaw resistant. The tests shall be conducted in cube of side length 180 mm to 300 mm ( $15d_a$  to  $25d_a$ ) or steel encased concrete cylinder. The splitting of concrete test cube shall be prevented by confining it. The top surface of the test member shall be covered with tap water up to a depth of 12 mm. Other exposed surfaces of the test cube shall be sealed to prevent evaporation of water.

**7.14.2** The test specimen shall be conditioned in temperature controlled chamber or equipment as per requirement of test series. The displacements shall be measured during the temperature cycles. The rate of increase of displacement shall reduce with increase in number of freeze/thaw cycles to a value almost equal to zero. Confined tension test set up in accordance with **5.5** shall be used for testing. The load displacement behavior and coefficient of variation shall be recorded for residual load test.

**7.14.3** The installed anchor shall be loaded to  $N_{sus}$  given by

$$N_{sus} = \frac{\tau_{Rk,uncr'60} \pi d_a h_{ef}}{(2.1 \gamma_{inst})}$$

where

$\gamma_f$  = Partial safety factor for installation  
 $\tau_{Rk,uncr'60}$  = Characteristic bond strength in uncracked concrete that correspond to 60

## MPa concrete strength

For torque controlled adhesive anchor,  $N_{sus} = \frac{N_{Rk,uncr160}}{(2.1\gamma_{inst})}$

$N_{Rk,uncr160}$  = Characteristic pull-out strength in uncracked concrete that correspond to

## 60 MPa concrete strength

**7.14.4** To perform the test the temperature of chamber shall be first raised to  $(+ 20 \pm 2)$  °C within 1 hour and the chamber temperature shall be maintained at  $(+ 20 \pm 2)$  °C for next 7 hours. The temperature of chamber shall be then lowered to  $(-20 \pm 2)$  °C within 2 hours and the chamber temperature shall be maintained at  $(-20 \pm 2)$  °C for next 14 hours. In total 50 such freeze/thaw cycle of raising and lowering the temperature shall be carried out. In case the test is interrupted, the samples shall be stored at a temperature of  $(-20 \pm 2)$  °C between the cycles. The displacements shall be measured during the temperature cycles. After completion of 50 cycles, a confined tension test as per **7.5** shall be carried out to failure (residual load test) at ambient temperature.

**7.15 Sensitivity to Large Crack Width**

The test is performed to determine sensitivity of anchor to large crack width passing through the anchor location.

NOTE - This test series may be omitted for anchors intended for use in uncracked concrete only.

**7.15.1** The anchors shall be installed in standard and high strength cracked concrete test member ( $\Delta w = 0.5$  mm) in accordance with **6.3**.

**7.15.2** The anchor specimen shall be connected to the loading device and pulled in tension to failure, after opening of crack to specified crack width.

**7.15.3** Confined tension test in accordance with **7.5** shall be performed for testing for adhesive anchors and unconfined tension in accordance with **7.4** shall be performed for torque controlled adhesive anchors.

**7.16 Sensitivity to Installation Direction**

These tests are performed to determine sensitivity to unfavorable installation direction.

**7.16.1** The anchors shall be installed in standard concrete test member of desired crack condition in accordance with **6.3**.

**7.16.2** If the manufacturer permits installation in all direction in MP11, then the anchor shall be installed and cured in overhead direction. If the manufacturer permits installation in vertically downward and horizontal direction only in MP11, then the anchor shall be installed and cured in horizontal direction.

**7.16.3** The test shall be carried out on the largest diameter of anchor specific to the manufacturer. After the anchor is cured the test member shall be rotated to floor position and the anchor shall be pulled in tension to failure in floor position. Observation (such as complete filling of annular gap, no dripping or loss of adhesive material after installation) during anchor installation shall be noted.

**7.16.4** Confined tension test in accordance with **7.5** shall be used for testing for adhesive anchors. For torque controlled adhesive anchors, unconfined tension test in accordance with **7.4** shall be performed.

NOTE – This test may be omitted if the MPII allows only downward installation of anchors.

### **7.17 Shear test**

This test is performed to determine characteristic strength of an anchor in shear in standard uncracked concrete, without edge and spacing influence. This test shall be required only if the distribution of steel strength along the length of the finished product cannot be easily determined. After the anchor is installed as required, it shall be connected to the shear test set up in accordance with **5.6**. There should be no gap between the anchor and the interchangeable sleeve/ fixture in the loading plate. The anchor shall be then loaded in shear to failure. The load displacement behavior and variation shall be recorded. The coefficient of variation shall be calculated.

**7.17.1** For tests to determine strength of anchor in shear in standard cracked concrete without edge and spacing influence for seismic evaluation, if different embedment depths are recommended for specific anchor diameter, the most unfavorable condition shall be tested. If the failure is caused by pull-out of anchor then the tests shall be repeated with larger embedment till these failure types are avoided.

NOTE – This test series may be omitted if the tests according to reference shear test are performed. In this case, the steel properties of reference shear test shall be used for normalizing results of Test Series S5.

### **7.18 Pry-out test**

The test is performed to determine the response of an anchor to pry-out failure. The test is performed with a group of four anchors installed in standard uncracked concrete. The spacing to be maintained as  $s = s'_{cr,N}$  and edge distance  $c \geq c'_{cr,N}$ . After the anchor is installed, it shall be connected to the shear test set up in accordance with **5.6**. The anchor shall be then loaded in shear to failure. The load displacement behavior and variation shall be recorded. The coefficient of variation shall be calculated. If steel failure is observed in the test, the spacing shall be reduced.

### **7.19 Pulsating tension tests**

This test is performed to determine strength of anchor in tension in standard cracked concrete without edge and spacing influence for seismic evaluation.

**7.19.1** For this test, anchors shall be installed in standard cracked concrete test member for seismic tests (with  $\Delta w = 0.5$  to  $0.8$  mm) in accordance with **6.4**. After the anchor is installed, the crack shall be opened to  $0.5$  mm.

**7.19.2** The anchor shall be then connected to the loading device and subjected to sinusoidal tension loads as recommended in Table 3 and as illustrated in Fig. 15, with load cycling frequency less than or equal to  $0.5$  Hz.

**7.19.3** The crack width shall be increased to  $0.8$  mm after completion of  $0.5 N/N_{max}$  load level cycle. The crack width shall be controlled during load cycle.

**7.19.4** To avoid servo control problems, the bottom of tension load pulses may be taken to a value slightly greater than zero but less than maximum of  $0.02N_{max}$  and 200 N.

**7.19.5** The maximum load of tension load cycle shall be determined using the following equations depending on the failure type observed in Test Series S1. If mixed failure type occurred in Test Series S1 then the largest value of the following equations shall be used.

$$N_{max} = \left[ \begin{array}{ll} 0.75N_{u,m,ts,S1} (f_{u,ts,S4}/f_{u,ts,S1}) & \text{For steel failure} \\ 0.75N_{u,m,ts,S1} (f_{cm,ts,S4}/f_{cm,ts,S1})^{n'} & \text{For bond failure} \\ 0.75N_{u,m,ts,S1} (f_{cm,ts,S4}/f_{cm,ts,S1})^{0.5} & \text{For all other failure types} \end{array} \right]$$

where

$N_{u,m,ts,S1}$  = Mean ultimate load in tension from Test Series S1

$f_{u,ts,S4}$  = Mean ultimate steel strength of anchor being used in Test Series S4

$f_{u,ts,S1}$  = Mean ultimate steel strength of anchor used in Test Series S1

$f_{cm,ts,S4}$  = Mean compressive strength of the concrete test member at the time of anchor testing in Test Series S4

$f_{cm,ts,S1}$  = Mean compressive strength of the concrete test member at the time of anchor testing in Test Series S1

$n'$  = Normalization factor to account for concrete strength

**7.19.6** The anchor shall be unloaded after completion of the tension load cycles and the dimension of crack width shall be checked.

**7.19.7** If the crack width decreases during the unloading of anchor then it shall be again opened to 0.8 mm. The residual capacity of anchor shall be then determined by conducting a pullout test to failure using confined tension set-up for adhesive anchors and unconfined test set-up for torque controlled adhesive anchors.

*Commentary – The test may be conducted with crack width of 0.8 mm for all load levels. Triangular load cycles may be used instead of sinusoidal load cycles.*

NOTE – If anchors from same production lot are used for Test Series S1 and this test then no normalization shall be required when calculating using following equation.

**7.19.8** The anchor displacement, crack width and the applied tension load cycle shall be continuously recorded using a data acquisition system. The displacement at maximum and minimum load cycles shall be plotted as a function of no. of load cycles.

**7.19.9** The load displacement behavior and variation of residual tension load test shall be recorded. The coefficient of variation shall be calculated.



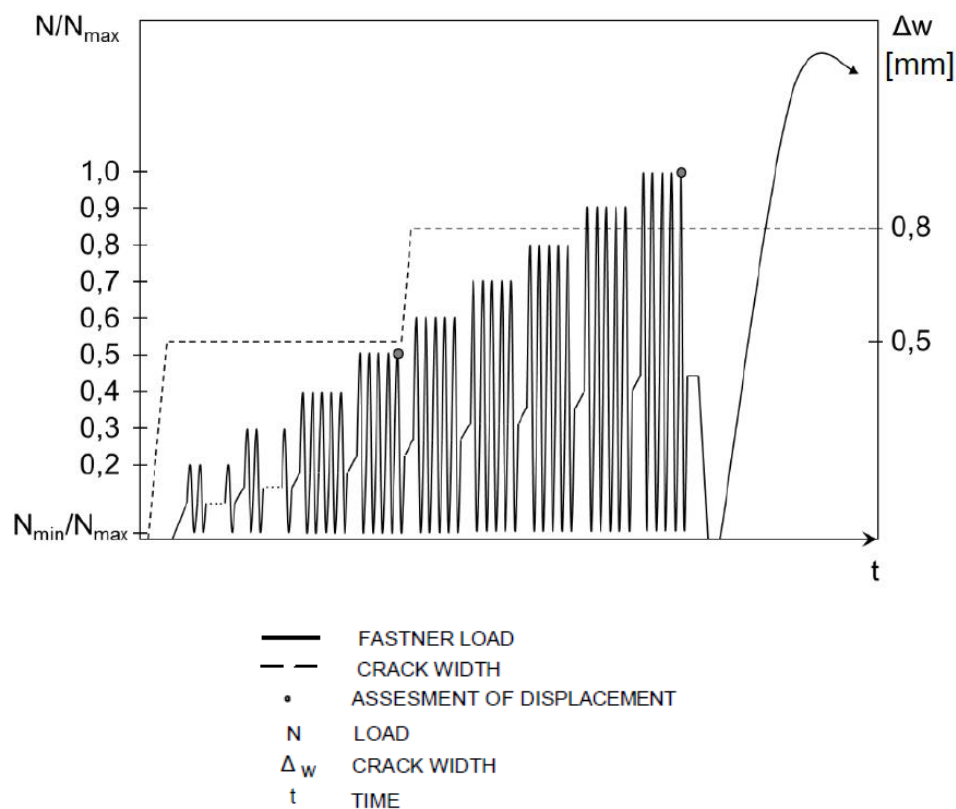

FIG. 15 VARIATION IN TENSION LOAD AMPLITUDE WITH NO. OF CYCLES

**Table 3 Variation in Tension Load Amplitude with No. of Cycles**

(Clause 7.19.2 and 8.2.5)

SI No.	$N/N_{max}$	No. of tension cycles	Variation in crack width $\Delta w$ with no. of tension cycles (mm)
(1)	(2)	(3)	(4)
i)	0.2	25	0.5
ii)	0.3	15	0.5
iii)	0.4	5	0.5
iv)	0.5	5	0.5
v)	0.6	5	0.8
vi)	0.7	5	0.8
vii)	0.8	5	0.8
viii)	0.9	5	0.8
ix)	1	5	0.8
	Total	75	

## 7.20 Alternating Shear tests

This test is performed to determine strength of anchor in shear in standard cracked concrete without edge and spacing influence for seismic evaluation.

**7.20.1** For this test, anchors shall be installed in standard cracked concrete test member for seismic tests (with  $\Delta w = 0.8$  mm) in accordance with **6.4**.

**7.20.2** Shear test set up for alternating shear in accordance with **5.6** shall be used for testing. After the anchor is installed, the crack shall be opened to 0.8 mm.

**7.20.3** The anchor shall be then connected to the loading device and subjected to sinusoidal shear loads as recommended in Table 4 and as illustrated in Fig. 16, with load cycling frequency less than or equal to 0.5 Hz. The load direction shall be parallel to the crack. The crack width shall be controlled during load cycle.

**7.20.4** To avoid servo control problems, the bottom of shear load pulses may be taken to a value slightly greater than zero but less than maximum of  $0.02V_{max}$  and 200 N.

The maximum load of shear load cycle is given by.

NOTE – If the anchors in Test Series S3 and S5 are from same production lot then the adjustment for different steel strength is not required in the equation for determining  $V_{max}$ .

$$V_{max} = 0.85V_{u,m,ts\_S3} (f_{u,ts\_S5} / f_{u,ts\_S3})$$

where

$V_{u,m,ts\_S3}$  = Mean ultimate shear load in shear from Test Series S3

$f_{u,ts\_S5}$  = Mean ultimate steel strength of anchor being used in Test Series S5

$f_{u,ts\_S3}$  = Mean ultimate steel strength of anchor used in Test Series S3

NOTE - To avoid or reduce occurrence of uncontrolled slip during load reversal, an approximation by two half sinusoidal load cycles (connected by a reduced speed & ramped load) or a simple triangular load cycle pattern may be used as illustrated in Fig. 17.

**7.20.5** The anchor shall be unloaded after completion of the shear load cycles and the dimension of crack width shall be checked.'

**7.20.6** If the crack width decreases during the unloading of anchor then it shall be again opened to 0.8 mm. The residual capacity of anchor shall be then determined by conducting a shear test to failure using shear test set up. If pull-out or pull-through failure occurs then the test shall be repeated with longer embedment depth to avoid these failure types.

**7.20.7** The anchor displacement, crack width and the applied shear load cycle shall be continuously recorded using a data acquisition system. The displacement at maximum and minimum load cycles shall be plotted as a function of no. of load cycles.

**7.20.8** The load displacement behavior and variation of residual shear load test shall be recorded.

NOTE – During the shear load cycle, failure may occur in embedded portion of the anchor. If such a failure occurs close to the embedded end of the fastener the residual capacity may not be significantly affected. Hence, in this case the failure of anchor may be overlooked. Attention should be paid to this aspect.

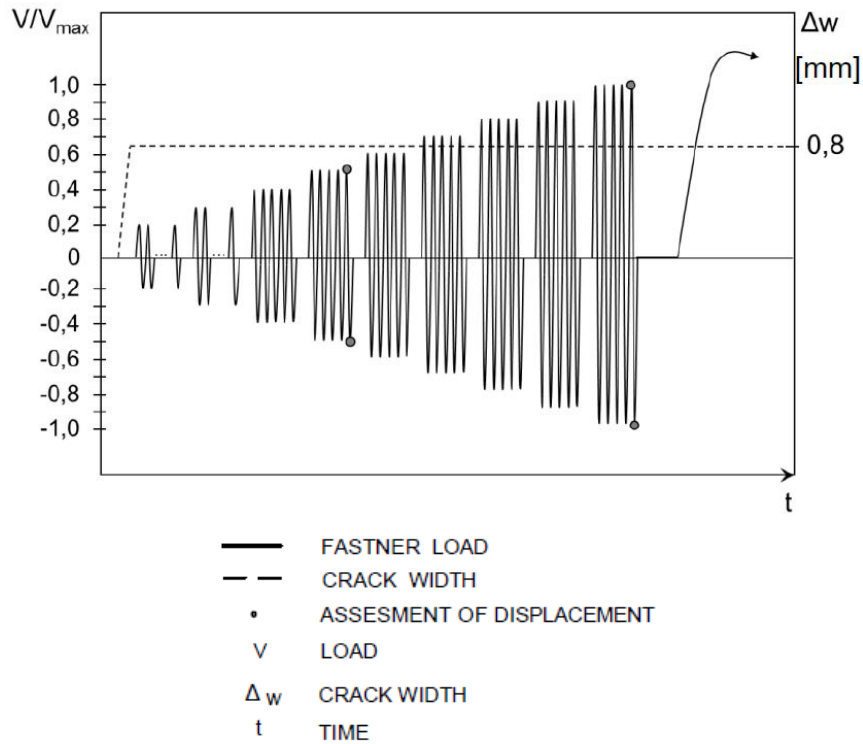

FIG. 16 VARIATION IN SHEAR LOAD AMPLITUDE WITH NO. OF CYCLES

**Table 4 Variation in Shear Load Amplitude with No. of Cycles**

(Clauses 7.20.3 and 8.2.6)

SI No. (1)	$V/V_{max}$ (2)	No. of shear load cycles (3)	Crack width $\Delta w$ (mm) (4)
1	0.2	25	0.8
2	0.3	15	0.8
3	0.4	5	0.8
4	0.5	5	0.8
5	0.6	5	0.8
6	0.7	5	0.8
7	0.8	5	0.8
8	0.9	5	0.8
9	1	5	0.8
	Total	75	

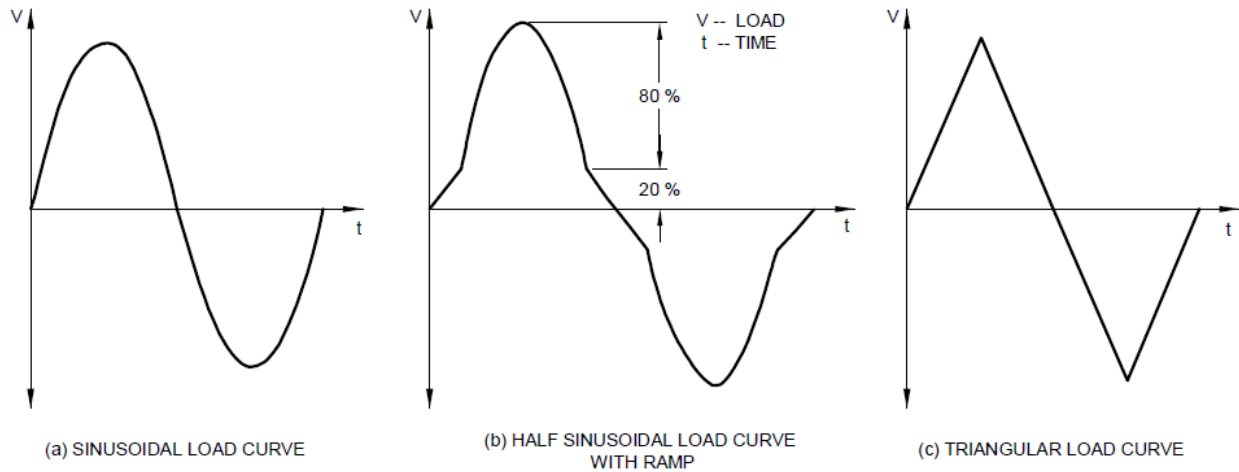

FIG. 17 PERMITTED SHEAR LOAD CYCLE PATTERNS

### 7.21 Crack Cycling Test

To determine strength of anchor in tension in standard cracked concrete without edge and spacing influence, when subjected to variation in crack width. This test is used for seismic evaluation.

**7.21.1** For this test, anchors shall be installed in standard cracked concrete test members for seismic tests (with  $\Delta w = 0.8$  mm) in accordance with 6.4. Only one anchor shall be tested at a time, that is, no other anchor shall be installed in the same crack.

**7.21.2** The load cycles to initiate crack and stabilize crack width w.r.t load applied on test member shall be carried out in accordance with Section 5, prior to installation of anchor. The initiated hairline crack should be closed by applying a centric compression force on test member in order to create similar initial conditions when either a test member with one crack plane or with multiple crack planes is used. The initial centric compression force,  $CF_{ini}$ , (applied prior to anchor installation) shall not be larger than the value given by

$$CF_{ini} = 0.01f_{cm,ts_{S6}}A_{TM}$$

where

$f_{cm,ts_{S6}}$  = Mean compressive strength of concrete test member at the time anchor testing in Test Series S6

$A_{s,TM}$  = Cross-section area of concrete test member

At the time of installation of adhesive anchor, the compression force  $CF_{ini}$  shall be released. The compression force  $CF_{ini}$  shall be reapplied only after the curing of adhesive anchor.

**7.21.3** Confined tension test set up in accordance with 5.5 shall be used for testing. For torque controlled adhesive anchors, unconfined tension test set-up in accordance with 5.4 shall be used for testing. The dial gauges for measuring crack width shall be set to zero prior to test. Any slack in loading mechanism shall be removed by application of sufficient load, prior to recording anchor displacements.

**7.21.4** After the anchor is installed, it shall be subjected to load  $N_{w1}$ . The load  $N_{w1}$  shall be determined using the following equations depending on the failure type observed in Test

Series S1. If mixed failure type occurred in Test Series S1 then the largest value of the following equations shall be used.

$$N_{w1} = \left[ \begin{array}{ll} 0.4N_{u,m,ts,S1} (f_{u,ts,S6}/f_{u,ts,S1}) & \text{For steel failure} \\ 0.4N_{u,m,ts,S1} (f_{cm,ts,S6}/f_{cm,ts,S1})^n & \text{For bond failure} \\ 0.4N_{u,m,ts,S1} (f_{cm,ts,S6}/f_{cm,ts,S1})^{0.5} & \text{For all other failure types} \end{array} \right]$$

where

$N_{u,m,ts,S1}$  = Mean ultimate load in tension from Test Series S1

$f_{u,ts,S6}$  = Mean ultimate steel strength of anchor being used in Test Series S6

$f_{u,ts,S1}$  = Mean ultimate steel strength of anchor used in Test Series S1

$f_{cm,ts,S6}$  = Mean compressive strength of the concrete test member at the time of anchor testing in Test Series S6

$f_{cm,ts,S1}$  = Mean compressive strength of the concrete test member at the time of anchor testing in Test Series S1

**7.21.5** The anchor with tension load  $N_{w1}$  shall be subjected to crack cycle as recommended in Table 5 and as illustrated in Fig. 18, with load cycling frequency less than or equal to 0.5 Hz. The first crack cycle shall be in the direction of crack closure achieved by application of compression load on the test member.

**7.21.6** During crack cycling, the crack shall be closed (that is  $\Delta w \leq 0.1 \text{ mm}$ ) by applying a centric compression force,  $CF$ , given by

$$CF = 0.1f_{cm,ts,S6}A_{TM}$$

#### NOTES

- 1 The initial crack  $w_{ini}$  width after applying the load  $N_{w1}$  may exceed the value of 0.1 mm. In this case, the crack cycle is performed starting with  $\Delta w = 0.1 \text{ mm}$ .
- 2 The centric compression force,  $CF$ , may be increased to a maximum value of  $0.15f_{c,ts,S6}A_{TM}$  if it is not possible to achieve crack with value of less than 0.1 mm using the centric compression force of  $0.1f_{c,ts,S6}A_{TM}$ .

**7.21.7** The crack width shall be increased in step by step manner as shown in Table 5. Before starting with crack cycle with width of 0.6 mm, the tension load on the anchor shall be increased to  $N_{w2}$ . The load  $N_{w2}$  shall be determined using the following equations depending on the failure type observed in Test Series S1. If mixed failure type occurred in Test Series S1 then the largest value of the following equations shall be used.

$$N_{w2} = \left[ \begin{array}{ll} 0.5N_{u,m,ts,S1} (f_{u,ts,S6}/f_{u,ts,S1}) & \text{For steel failure} \\ 0.5N_{u,m,ts,S1} (f_{cm,ts,S6}/f_{cm,ts,S1})^n & \text{For bond failure} \\ 0.5N_{u,m,ts,S1} (f_{cm,ts,S6}/f_{cm,ts,S1})^{0.5} & \text{For all other failure types} \end{array} \right]$$

NOTE – If anchors from same production lot are used for Test Series S1 and this test then no normalization shall be required when calculating the load  $N_{w1}$  and  $N_{w2}$ .

**7.21.8** The anchor shall be unloaded after completion of the tension load cycles and the dimension of crack width shall be checked.

**7.21.9** If the crack width decreases during the unloading of anchor then it shall be again opened to 0.8 mm. The residual capacity of anchor shall be then determined by conducting a pullout test to failure.

**7.21.10** The anchor displacement, crack width and the applied tension load shall be continuously recorded using a data acquisition system. The displacement at maximum and minimum crack width along with applied tension load shall be plotted as a function of no. of crack cycles.

**7.21.11** The load displacement behavior and coefficient of variation of residual tension load test shall be recorded.

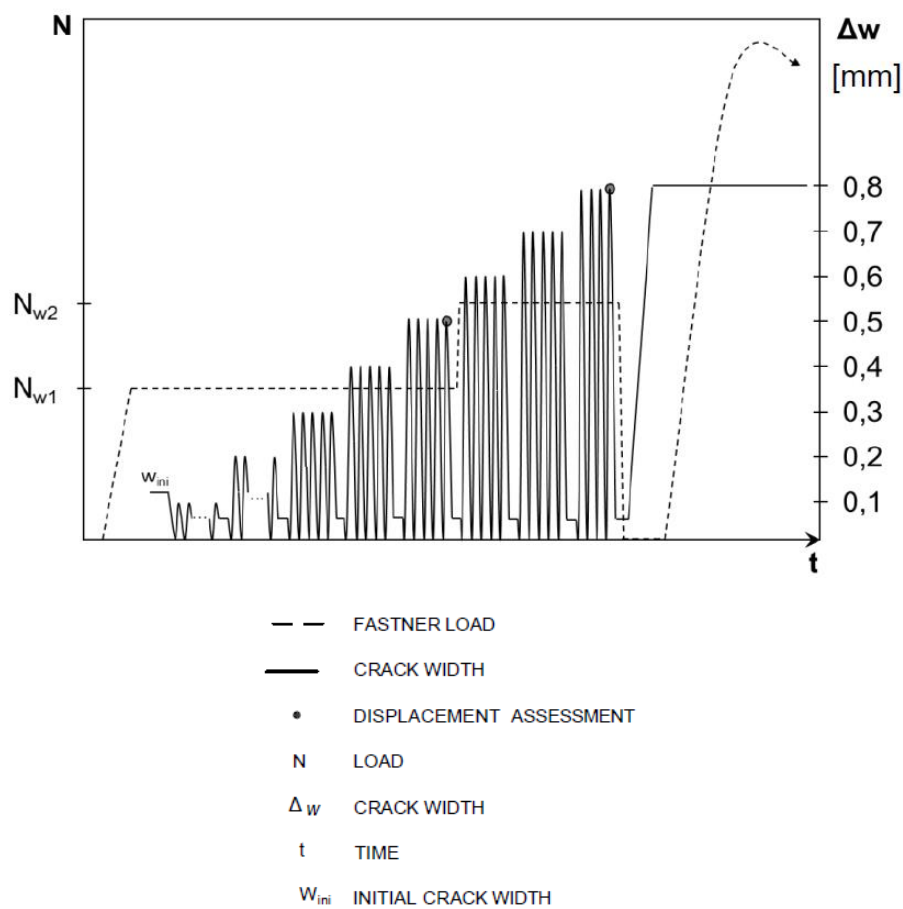

FIG. 18 VARIATION IN CRACK WIDTH WITH NO. OF CYCLES

**Table 5 Variation in Crack Width with No. of Cycles**

(CLAUSES 7.21.5 AND 7.21.7)

SI No.	Anchor load	No. of crack cycles	Variation in crack width $\Delta w$ with no. of cycles (mm)
(1)	(2)	(3)	(4)
i)	$N_{w1}$	20	0.1
ii)	$N_{w1}$	10	0.2
iii)	$N_{w1}$	5	0.3
iv)	$N_{w1}$	5	0.4
v)	$N_{w1}$	5	0.5
vi)	$N_{w2}$	5	0.6
vii)	$N_{w2}$	5	0.7
viii)	$N_{w2}$	4	0.8
	Total	59	

**7.22 Test Report**

As a minimum requirement, the report shall include at least the following information.

**7.22.1 General**

- a) Type of anchor along with description
- b) Parameters for anchor identification such as, dimensions, materials, coating, production method
- c) Name and address of manufacturer & test laboratory
- d) Date on which the test was performed
- e) Name of person responsible for test
- f) Type and number of tests such as, tension, shear, short term or repeated load test
- g) Test setup, illustrated by sketches or photographs
- h) Particulars concerning support of test setup on the test member

**7.22.2 Test Members**

- a) Grade of hardened concrete
- b) Composition and properties of fresh concrete such as, consistency, density, aggregate type etc.
- c) Date of manufacture/ casting
- d) Dimension of control specimens, and/or cores (if applicable); measured value of compression strength at the time of testing (individual and average value)
- e) Dimensions of test member
- f) Nature and positioning of any reinforcement
- g) Test face of concrete – form face or cast face

**7.22.3 Anchor Installation**

- a) Information on the positioning of the anchor such as, placed on the formed or cast face of the test member
- b) Distances of anchors from edges of test member and between adjacent anchors

- c) Tools employed for anchor installation, such as, impact drilling tool, drilling hammer, other equipment like torque wrench, etc.
- d) Type of drill bit, manufacturer's mark, and measured drill bit dimensions, particularly the effective diameter,  $d_{cut}$ , of the hard metal drill bit
- e) Information on the direction of drilling
- f) Information on cleaning of the hole
- g) Depth of drill hole
- h) Width of crack when installing the anchor (where applicable)
- i) Depth of anchorage
- j) Tightening torque or other parameters for control of installation, such as, penetration depth of the expansion element of displacement controlled anchors
- k) Displacement of anchor at the applied torque moment (if measured)
- l) Quality and type of screws and nuts employed
- m) Length of thread engagement (where applicable)

#### **7.22.4 Measured Values**

- a) Parameters of load application e.g., rate of increase of load, size of load increase steps, etc.
- b) Displacements measured as a function of the applied load
- c) Any special observations concerning application of the load
- d) Width of crack during the loading of the anchor (where applicable)
- e) Failure load & cause(s) of rupture or failure
- f) Radius (maximum radius, minimum radius) and height of a concrete cone produced in the test (where applicable)
- g) Particulars of tests with crack cycles
  - 1) Constant load on anchor and method of applying it
  - 2) Frequency of crack openings
  - 3) Anchor displacements and crack width  $\Delta w_1$ ,  $\Delta w_2$  as a function of the number of crack openings
- h) Particulars of repeated load tests
  - 1) Minimum and maximum load
  - 2) Frequency & number of cycles
  - 3) Displacements as function of the number of cycles
- j) Particulars of test for determining the minimum spacing and edge distance
  - 1) Increment of torque
  - 2) Number of revolutions
  - 3) Torque moment at the forming of a hairline crack at each anchor
  - 4) Maximum torque moment applied to each anchor
- k) Particulars of torque test
  - 1) Increment of torque
  - 2) Tension force as a function of the applied torque moment

#### **7.22.5 Particulars of Identification**

- a) Dimensions of the parts of the anchor and the drilling & installation tools
- b) Properties such as, tensile strength, elastic limit, elongation at rupture, hardness and surface conditions of anchor cone and sleeve, if applicable

The above measurements in **7.22.1** to **7.22.4** shall be recorded for each test.



**Table 2 Summary of Tests for Evaluating Performance of Post-Installed Adhesive Anchors**  
(Clauses 6.5.2, 6.5.3, 7.1.1, 7.4.3, 8.2.1 and Annex B)

Test Series No. (1)	Title (2)	Concrete Strength (3)	Crack width $\Delta w$ (mm) (4)	Anchor diameters to be tested <sup>(1)</sup> (5)	Effective embedment $(h_{ef})^2$ (6)	Minimum no. of samples to be tested for each anchor size (7)	Other deviations from standard installation and test conditions, if any (8)	Measurement and Assessment Checks (TS – Test Series) (9)	Test Applicable to (10)	Test Reference section (11)	Assessment option (12)
<b>Tests to check steel strength</b>											
1	Steel capacity test	-	-	All	-	5		Assessment as per <b>8.2.1(a)</b>	AA, TCAA	<b>7.2</b>	B, C
2	Maximum torque moment test	High	0	All	$7d_a$	5		Determine $N_{u,m}$ and $N_{u,95\%}$ @ $1.3T_{inst}$ Assessment as per <b>8.2.1(b)</b>	AA, TCAA	<b>7.3</b>	B, C
<b>Reference tension tests with confined test set up <sup>(4)</sup></b>											
3	Tension test for bond strength	Standard	0	All	$7d_a$	5		Determine $N_{u,m}$ , $N_{u,5\%}$ and $v_F$ Determine $\tau_{u,m}$ and $\tau_{u,5\%}$ Check $v_F \leq 15\%$ Check $v_{\delta}^{(9)} \leq 25\%$ Determine $\beta_{vF}^{(8)}$ Assessment as per <b>8.2.2</b> and <b>8.2.8</b>	AA, TCAA	<b>7.5</b>	B, C
4	Tension test for bond strength	High	0	S/M/L	$7d_a$	5		Determine $N_{u,m}$ , $N_{u,5\%}$ and $v_F$ Determine $\tau_{u,m}$ and $\tau_{u,5\%}$ Check $v_F \leq 15\%$ Check $v_{\delta}^{(9)} \leq 25\%$ Determine $\beta_{vF}^{(8)}$ Assessment as per <b>8.2.2</b> and <b>8.2.8</b>		<b>7.5</b>	B, C
5	Tension test for bond strength	Standard	0.3	S/M/L	$7d_a$	5		Determine $N_{u,m}$ , $N_{u,5\%}$ and $v_F$ Determine $\tau_{u,m}$ and $\tau_{u,5\%}$ Check $v_F \leq 15\%$		<b>7.5</b>	B

Test Series No. (1)	Title (2)	Concrete Strength (3)	Crack width $\Delta w$ (mm) (4)	Anchor diameters to be tested <sup>(1)</sup> (5)	Effective embedment $(h_{ef})^2$ (6)	Minimum no. of samples to be tested for each anchor size (7)	Other deviations from standard Installation and test conditions, if any (8)	Measurement and Assessment Checks (TS – Test Series) (9)	Test Applicable to (10)	Test Reference section (11)	Assessment option (12)
								Check $v_{\delta}^{(9)} \leq 25\%$ Determine $\beta_{vF}^{(8)}$ Assessment as per <b>8.2.2</b> and <b>8.2.8</b>			
6	Tension test for bond strength	High	0.3	S/M/L	$7d_a$	5		Determine $N_{u,m}$ , $N_{u,5\%}$ and $v_F$ Determine $\tau_{u,m}$ and $\tau_{u,5\%}$ Check $v_F \leq 15\%$ Check $v_{\delta}^{(9)} \leq 25\%$ Determine $\beta_{vF}^{(8)}$ Assessment as per <b>8.2.2</b> and <b>8.2.8</b>		7.5	B
7	Tension test for sensitivity to cleaning	Standard	0	S/M/L	Max	5		Determine $N_{u,m}$ , $N_{u,5\%}$ and $v_F$ Determine $\tau_{u,m}$ and $\tau_{u,5\%}$ Check $v_F \leq 15\%$ Check $v_{\delta}^{(9)} \leq 25\%$ Determine $\beta_{vF}^{(8)}$ Assessment as per <b>8.2.2</b>		7.5	B, C
8	Tension test for sustained load <sup>(6)</sup> (a) at ambient temperature (b) at maximum long term temperature (c) at minimum installation temperature < 0°C	Standard	0	M	$7d_a$	(a) 5 (b) 5 (c) 5		Determine $N_{u,m}$ , $N_{u,5\%}$ and $v_F$ Determine $\tau_{u,m}$ and $\tau_{u,5\%}$ Check $v_F \leq 15\%$ Check $v_{\delta}^{(9)} \leq 25\%$ Determine $\beta_{vF}^{(8)}$ Assessment as per <b>8.2.2</b>		7.5	B, C
9	Tension test for freeze-thaw	High	0	M	$7d_a$	5		Determine $N_{u,m}$ , $N_{u,5\%}$ and $v_F$ Determine $\tau_{u,m}$ and $\tau_{u,5\%}$ Check $v_F \leq 15\%$ Check $v_{\delta}^{(9)} \leq 25\%$ Determine $\beta_{vF}^{(8)}$		7.5	B, C

Test Series No. (1)	Title (2)	Concrete Strength (3)	Crack width $\Delta w$ (mm) (4)	Anchor diameters to be tested <sup>(1)</sup> (5)	Effective embedment $(h_{ef})^2$ (6)	Minimum no. of samples to be tested for each anchor size (7)	Other deviations from standard Installation and test conditions, if any (8)	Measurement and Assessment Checks (TS – Test Series) (9)	Test Applicable to (10)	Test Reference section (11)	Assessment option (12)
								Assessment as per <b>8.2.2</b>			
10	Slice test	Standard	0	M	30 mm	10	Installation as per 7.11	Assessment as per <b>8.2.2(j)</b>		7.11	B, C
<b>Reference tension tests with unconfined test set up</b>											
11	Tension test to determine characteristic resistance (without end and spacing influence) <sup>3,7</sup>	Standard	0	S/M/L	Min	5		Determine $N_{u,m}$ , $N_{u,5\%}$ and $v_F$ Check $v_F \leq 15\%$ Check $v_\delta^{(9)} \leq 25\%$ Determine $\beta_{vF}^{(8)}$ Assessment as per <b>8.2.2</b>	AA, TCAA	7.4	B, C (optional for AA)
12		High	0	S/M/L	Min	5		Determine $N_{u,m}$ , $N_{u,5\%}$ and $v_F$ Check $v_F \leq 15\%$ Check $v_\delta^{(9)} \leq 25\%$ Determine $\beta_{vF}^{(8)}$ Assessment as per <b>8.2.2</b>		7.4	B, C (optional for AA)
13		Standard	0.3	S/M/L	Min	5		Determine $N_{u,m}$ , $N_{u,5\%}$ and $v_F$ Check $v_F \leq 15\%$ Check $v_\delta^{(9)} \leq 25\%$ Determine $\beta_{vF}^{(8)}$ Assessment as per <b>8.2.2</b>		7.4	B (optional for AA)
14		High	0.3	S/M/L	Min	5		Determine $N_{u,m}$ , $N_{u,5\%}$ and $v_F$ Check $v_F \leq 15\%$ Check $v_\delta^{(9)} \leq 25\%$ Determine $\beta_{vF}^{(8)}$ Assessment as per <b>8.2.2</b>		7.4	Option B (optional for AA)
15	Test to determine critical edge distance to prevent splitting under load	Standard	0	S/M/L	Min	4	$c = c'_{cr,sp}$ from both edge $D = D_{min}$	Determine $N_{u,m}$ , $N_{u,5\%}$ and $v_F$ Check $v_F \leq 15\%$ Assessment as per <b>8.2.7</b>	AA, TCAA	7.4	B, C

Test Series No. (1)	Title (2)	Concrete Strength (3)	Crack width $\Delta w$ (mm) (4)	Anchor diameters to be tested <sup>(1)</sup> (5)	Effective embedment $(h_{ef})^2$ (6)	Minimum no. of samples to be tested for each anchor size (7)	Other deviations from standard Installation and test conditions, if any (8)	Measurement and Assessment Checks (TS – Test Series) (9)	Test Applicable to (10)	Test Reference section (11)	Assessment option (12)
16	Tension test for minimum embedment depth	Standard	0	S	Min.	20	Anchor group as per <b>7.4.2</b>	Determine the theoretical concrete cone capacity ( $N_{Rk,c}$ ) Ultimate failure load $\geq (0.9 N_{Rk,c} / 0.75)$	AA, TCAA	<b>7.4</b>	B, C
<b>Test to determine shear strength</b>											
17	Shear test to determine characteristic resistance (without end and spacing influence)	Standard	0	All	Min	5		Determine $V_{u,m}$ , $V_{u,5\%}$ and $v_F$ Check $v_F \leq 15\%$ Assessment as per <b>8.3.1 and 8.3.4</b>	AA, TCAA	<b>7.17</b>	B, C
18	Pry-out test	Standard	0	All	Min	5		Determine $V_{u,m}$ , $V_{u,5\%}$ and $v_F$ Check $v_F \leq 15\%$ Assessment as per <b>8.3.2</b>		<b>7.18</b>	B, C
<b>Tests to determine pull-out strength</b>											
19	Minimum edge and spacing	Standard	0	S/M/L	Min	5 (double anchor group)	Anchor group as per <b>7.6</b>	Assessment as per <b>8.2.6</b>	AA, TCAA	<b>7.6</b>	B, C
20	Tension test to determine characteristic resistance at maximum long term temperature	Standard	0	M	Min	5	Installation as per <b>7.7</b>	Determine $N_{u,m}$ , $N_{u,5\%}$ and $v_F$ Check $v_F \leq 20\%$ Check $v_\delta^{(9)} \leq 25\%$ Determine $\beta_{vF}^{(8)}$ Determine $\alpha_2$ Assessment as per <b>8.2.2</b>	AA, TCAA	<b>7.7</b>	B, C
21	Tension test to determine characteristic resistance at maximum short term temperature	Standard	0	M	Min	5	Installation as per <b>7.7</b>	Determine $N_{u,m}$ , $N_{u,5\%}$ and $v_F$ Check $v_F \leq 20\%$ Check $v_\delta^{(9)} \leq 25\%$ Determine $\beta_{vF}^{(8)}$ Determine $\alpha_3$ Assessment as per <b>8.2.2</b>		<b>7.7</b>	B, C

Test Series No. (1)	Title (2)	Concrete Strength (3)	Crack width $\Delta w$ (mm) (4)	Anchor diameters to be tested <sup>(1)</sup> (5)	Effective embedment $(h_{ef})^2$ (6)	Minimum no. of samples to be tested for each anchor size (7)	Other deviations from standard Installation and test conditions, if any (8)	Measurement and Assessment Checks (TS – Test Series) (9)	Test Applicable to (10)	Test Reference section (11)	Assessment option (12)
22	Minimum curing time at minimum installation temperature	Standard	0	M	Min	5	Installation as per <b>7.8.2</b>	Determine $N_{u,m}$ , $N_{u,5\%}$ and $v_F$ Check $v_F \leq 15\%$ Check $v_\delta^{(9)} \leq 25\%$ Determine $\beta_{vF}^{(8)}$ Assessment as per <b>8.2.2</b>	AA, TCAA	<b>7.8</b>	B, C
23	Minimum curing time at ambient temperature	Standard	0	M	Min	5+5	Installation as per <b>7.8.3</b>	Determine $N_{u,m}$ , $N_{u,5\%}$ and $v_F$ Check $v_F \leq 15\%$ Check $v_\delta^{(9)} \leq 25\%$ Determine $\beta_{vF}^{(8)}$ Assessment as per <b>8.2.2</b>		<b>7.8</b>	B, C
24	Tension test for sensitivity to reduced cleaning in dry concrete <sup>(4)</sup>	Standard	0	S/M/L	Max	5	Installation as per <b>6.6</b> and <b>6.6.13</b>	Determine $N_{u,m}$ , $N_{u,5\%}$ and $v_F$ Determine $\tau_{u,m}$ and $\tau_{u,5\%}$ Check $v_F \leq 20\%$ Check $v_\delta^{(9)} \leq 40\%$ Determine $\beta_{vF}^{(8)}$ Determine $\alpha$ (using Ref TS 7) Assessment as per <b>8.2.2 (a)</b> and <b>8.2.5</b>	AA	<b>7.5,</b>	B, C
		Standard	0.3	S/M/L	-	10	Installation as per <b>6.6</b> and <b>6.6.13</b>	Determine $N_{u,m}$ , $N_{u,5\%}$ and $v_F$ Check $v_F \leq 20\%$ Check $v_\delta^{(9)} \leq 40\%$ Determine $\beta_{vF}^{(8)}$ Determine $\alpha$ (using Ref TS 7) Assessment as per <b>8.2.2</b> and <b>8.2.5</b>	TCAA	<b>7.4,</b>	B
25	Tension test for sensitivity to reduced cleaning in water saturated concrete <sup>(4)</sup>	Standard	0	S/M/L	Max	5	Installation as per <b>6.6</b> and <b>6.6.13</b>	Determine $N_{u,m}$ , $N_{u,5\%}$ and $v_F$ Determine $\tau_{u,m}$ and $\tau_{u,5\%}$ Check $v_F \leq 20\%$ Check $v_\delta^{(9)} \leq 40\%$ Determine $\beta_{vF}^{(8)}$	AA	<b>7.5,</b>	B, C

Test Series No. (1)	Title (2)	Concrete Strength (3)	Crack width $\Delta w$ (mm) (4)	Anchor diameters to be tested <sup>(1)</sup> (5)	Effective embedment $(h_{ef})^2$ (6)	Minimum no. of samples to be tested for each anchor size (7)	Other deviations from standard Installation and test conditions, if any (8)	Measurement and Assessment Checks (TS – Test Series) (9)	Test Applicable to (10)	Test Reference section (11)	Assessment option (12)
								Determine $\alpha$ (using Ref TS 7) Assessment as per <b>8.2.2</b> and <b>8.2.5</b>			
		Standard	0.3	S/M/L	-	10	Installation as per <b>6.6</b> and <b>6.6.13</b>	Determine $N_{u,m}$ , $N_{u,5\%}$ and $v_F$ Check $v_F \leq 20\%$ Check $v_\delta^{(9)} \leq 40\%$ Determine $\beta_{v_F}^{(8)}$ Determine $\alpha$ (using Ref TS 7) Assessment as per <b>8.2.2</b> and <b>8.2.5</b>	TCAA	<b>7.4</b>	B
26	Tension test for sensitivity to reduced cleaning in water filled holes <sup>(4)</sup>	Standard	0	S/M/L	Max	5	Installation as per <b>6.6</b> and <b>6.6.13</b>	Determine $N_{u,m}$ , $N_{u,5\%}$ and $v_F$ Determine $\tau_{u,m}$ and $\tau_{u,5\%}$ Check $v_F \leq 20\%$ Check $v_\delta^{(9)} \leq 40\%$ Determine $\beta_{v_F}^{(8)}$ Determine $\alpha$ (using Ref TS 7) Assessment as per <b>8.2.2</b> and <b>8.2.5</b>	AA	<b>7.5</b>	B, C
		Standard	0.3	S/M/L	-	10	Installation as per <b>6.6</b> and <b>6.6.13</b>	Determine $N_{u,m}$ , $N_{u,5\%}$ and $v_F$ Check $v_F \leq 20\%$ Check $v_\delta^{(9)} \leq 40\%$ Determine $\beta_{v_F}^{(8)}$ Determine $\alpha$ (using Ref TS 7) Assessment as per <b>8.2.2</b> and <b>8.2.5</b>	TCAA	<b>7.4</b>	B
27	Tension test for sensitivity to mixing technique	Standard	0	M	Max	5	Installation as per <b>6.6</b> and <b>6.6.13</b>	Determine $N_{u,m}$ , $N_{u,5\%}$ and $v_F$ Determine $\tau_{u,m}$ and $\tau_{u,5\%}$ Check $v_F \leq 20\%$	AA	<b>7.5</b>	B, C

Test Series No. (1)	Title (2)	Concrete Strength (3)	Crack width $\Delta w$ (mm) (4)	Anchor diameters to be tested <sup>(1)</sup> (5)	Effective embedment $(h_{ef})^2$ (6)	Minimum no. of samples to be tested for each anchor size (7)	Other deviations from standard Installation and test conditions, if any (8)	Measurement and Assessment Checks (TS – Test Series) (9)	Test Applicable to (10)	Test Reference section (11)	Assessment option (12)
								Check $v_{\delta}^{(9)} \leq 40\%$ Determine $\beta_{vF}^{(8)}$ Determine $\alpha$ (using Ref TS 7) Assessment as per <b>8.2.2</b> and <b>8.2.5</b>			
		Standard	0.3	M	-	10	Installation as per <b>6.6</b> and <b>6.6.13</b>	Determine $N_{u,m}$ , $N_{u,5\%}$ and $v_F$ Check $v_F \leq 20\%$ Check $v_{\delta}^{(9)} \leq 40\%$ Determine $\beta_{vF}^{(8)}$ Determine $\alpha$ (using Ref TS 7) Assessment as per <b>8.2.2</b> and <b>8.2.5</b>	TCAA	<b>7.4</b>	B
28	Repeated load test <sup>5</sup>	Standard	0	M	$7d_a$	5		For residual load test: Determine $N_{u,m}$ , $N_{u,5\%}$ and $v_F$ Check $v_F \leq 20\%$ & $v_{\delta} \leq 40\%$ Determine $\beta_{vF}^{(5)}$ Determine $\alpha$ (using Ref TS 3) <sup>(5)</sup> ; $\alpha_{reqd}=1.0$ Assessment as per <b>8.2.2</b>	AA, TCAA	<b>7.9</b>	B, C
29	Sensitivity to large crack width in standard concrete	Standard	0.5	S/M/L	$7d_a$	5	Confined test set up	Determine $N_{u,m}$ , $N_{u,5\%}$ and $v_F$ Check $v_F \leq 20\%$ Check $v_{\delta}^{(9)} \leq 40\%$ Determine $\beta_{vF}^{(8)}$ Determine $\alpha$ (using Ref TS 5) <sup>(5)</sup> ; $\alpha_{reqd}=0.8$ Assessment as per <b>8.2.2</b>	AA	<b>7.15</b>	B
	Sensitivity to large crack width in high strength concrete	High	0.5	S/M/L	$7d_a$	5	Confined test set up	Determine $N_{u,m}$ , $N_{u,5\%}$ and $v_F$ Check $v_F \leq 20\%$	AA	<b>7.15</b>	B

Test Series No. (1)	Title (2)	Concrete Strength (3)	Crack width $\Delta w$ (mm) (4)	Anchor diameters to be tested <sup>(1)</sup> (5)	Effective embedment $(h_{ef})^2$ (6)	Minimum no. of samples to be tested for each anchor size (7)	Other deviations from standard Installation and test conditions, if any (8)	Measurement and Assessment Checks (TS – Test Series) (9)	Test Applicable to (10)	Test Reference section (11)	Assessment option (12)
								Check $v_{\delta}^{(9)} \leq 40\%$ Determine $\beta_{vF}^{(8)}$ Determine $\alpha$ (using Ref TS 6) <sup>(5)</sup> ; $\alpha_{reqd}=0.8$ Assessment as per <b>8.2.2</b>			
	Sensitivity to large crack width in standard concrete for torque controlled adhesive anchors	Standard	0.5	S/M/L	-	10	Unconfined test set up	Determine $N_{u,m}$ , $N_{u,5\%}$ and $v_F$ Check $v_F \leq 20\%$ Check $v_{\delta}^{(9)} \leq 40\%$ Determine $\beta_{vF}^{(8)}$ Determine $\alpha$ (using Ref TS 13) <sup>(5)</sup> ; $\alpha_{reqd}=0.8$ Assessment as per <b>8.2.2</b>	TCAA	<b>7.15</b>	B
	Sensitivity to large crack width in high strength concrete for torque controlled adhesive anchors	High	0.5	S/M/L	-	10	Unconfined test set up	Determine $N_{u,m}$ , $N_{u,5\%}$ and $v_F$ Check $v_F \leq 20\%$ Check $v_{\delta}^{(9)} \leq 40\%$ Determine $\beta_{vF}^{(8)}$ Determine $\alpha$ (using Ref TS 14) <sup>(5)</sup> ; $\alpha_{reqd}=0.8$ Assessment as per <b>8.2.2</b>	TCAA	<b>7.15</b>	B
30	Crack cycling test	Standard	0.1 to 0.3	All	$7d_a$	5	Confined test set up	For residual load test: Determine $N_{u,m}$ , $N_{u,5\%}$ and $v_F$ Check $v_F \leq 20\%$ & $v_{\delta} \leq 40\%$ Determine $\beta_{vF}^{(5)}$ Determine $\alpha$ (using Ref TS 5) <sup>(5)</sup> ; $\alpha_{reqd}=0.9$ Assessment as per <b>8.2.2</b> and <b>8.2.8</b>	AA	<b>7.13</b>	B
		Standard	0.1 to 0.3	All	-	10	Unconfined	For residual load test: Determine $N_{u,m}$ , $N_{u,5\%}$ and $v_F$ Check $v_F \leq 20\%$ & $v_{\delta} \leq 40\%$	TCAA	<b>7.13</b>	B



Test Series No. (1)	Title (2)	Concrete Strength (3)	Crack width $\Delta w$ (mm) (4)	Anchor diameters to be tested <sup>(1)</sup> (5)	Effective embedment $(h_{ef})^2$ (6)	Minimum no. of samples to be tested for each anchor size (7)	Other deviations from standard Installation and test conditions, if any (8)	Measurement and Assessment Checks (TS – Test Series) (9)	Test Applicable to (10)	Test Reference section (11)	Assessment option (12)
								Determine $\beta_{vF}$ <sup>(5)</sup> Determine $\alpha$ (using Ref TS 13) <sup>(5)</sup> ; $\alpha_{reqd}=0.9$ Assessment as per <b>8.2.2</b> and <b>8.2.8</b>			
31	Sustained load test at ambient temperature	Standard	0	M	$7d_a$	5	Confined test set up	For residual load test: Determine $N_{u,m}$ , $N_{u,5\%}$ and $v_F$ Check $v_F \leq 20\%$ & $v_\delta \leq 40\%$ Determine $\beta_{vF}$ <sup>(5)</sup> Determine $\alpha$ (using Ref TS 8a) <sup>(5)</sup> ; $\alpha_{reqd}=0.9$ Assessment as per <b>8.2.2</b> and <b>8.2.8</b>	AA	<b>7.10</b>	B, C
		Standard	0	M	-	5	Confined test set up	For residual load test: Determine $N_{u,m}$ , $N_{u,5\%}$ and $v_F$ Check $v_F \leq 20\%$ & $v_\delta \leq 40\%$ Determine $\beta_{vF}$ <sup>(5)</sup> Determine $\alpha$ (using Ref TS 8a) <sup>(5)</sup> ; $\alpha_{reqd}=0.9$ Assessment as per <b>8.2.2</b> and <b>8.2.8</b>	TCAA	<b>7.10</b>	B, C
32	Sustained load test at maximum long term temperature	Standard	0	M	$7d_a$	5	Confined test set up	For residual load test: Determine $N_{u,m}$ , $N_{u,5\%}$ and $v_F$ Check $v_F \leq 20\%$ & $v_\delta \leq 40\%$ Determine $\beta_{vF}$ <sup>(5)</sup> Determine $\alpha$ (using Ref TS 8b) <sup>(5)</sup> ; $\alpha_{reqd}=0.9$ Assessment as per <b>8.2.2</b> and <b>8.2.8</b>	AA	<b>7.10</b>	B, C

Test Series No. (1)	Title (2)	Concrete Strength (3)	Crack width $\Delta w$ (mm) (4)	Anchor diameters to be tested <sup>(1)</sup> (5)	Effective embedment $(h_{ef})^2$ (6)	Minimum no. of samples to be tested for each anchor size (7)	Other deviations from standard Installation and test conditions, if any (8)	Measurement and Assessment Checks (TS – Test Series) (9)	Test Applicable to (10)	Test Reference section (11)	Assessment option (12)
		Standard	0	M	-	5	Confined test set up	For residual load test: Determine $N_{u,m}$ , $N_{u,5\%}$ and $v_F$ Check $v_F \leq 20\%$ & $v_\delta \leq 40\%$ Determine $\beta_{v_F}^{(5)}$ Determine $\alpha$ (using Ref TS 8b) <sup>(5)</sup> ; $\alpha_{reqd}=0.9$ Assessment as per <b>8.2.2</b> and <b>8.2.8</b>	TCAA	<b>7.10</b>	B, C
33	Sensitivity to freeze-thaw conditions	High	0	M	$7d_a$	5	Installation as per 7.14	For residual load test: Determine $N_{u,m}$ , $N_{u,5\%}$ and $v_F$ Check $v_F \leq 20\%$ & $v_\delta \leq 40\%$ Determine $\beta_{v_F}^{(5)}$ Determine $\alpha$ (using Ref TS 9) <sup>(5)</sup> ; $\alpha_{reqd}=0.9$ Assessment as per <b>8.2.2</b>	AA	<b>7.14</b>	B, C
		High	0	M	-	5	Installation as per 7.14	For residual load test: Determine $N_{u,m}$ , $N_{u,5\%}$ and $v_F$ Check $v_F \leq 20\%$ & $v_\delta \leq 40\%$ Determine $\beta_{v_F}^{(5)}$ Determine $\alpha$ (using Ref TS 9) <sup>(5)</sup> ; $\alpha_{reqd}=0.9$ Assessment as per <b>8.2.2</b>	TCAA	<b>7.14</b>	B, C
34	Sensitivity to installation direction	Standard	0	Max	$7d_a$	5	Installation as per 7.16 Confined test set up	For residual load test: Determine $N_{u,m}$ , $N_{u,5\%}$ and $v_F$ Check $v_F \leq 20\%$ & $v_\delta \leq 40\%$ Determine $\beta_{v_F}^{(5)}$ Determine $\alpha$ (using Ref TS 3) <sup>(5)</sup> ; $\alpha_{reqd}=0.9$ Assessment as per <b>8.2.2</b>	AA	<b>7.16</b>	B, C

Test Series No. (1)	Title (2)	Concrete Strength (3)	Crack width $\Delta w$ (mm) (4)	Anchor diameters to be tested <sup>(1)</sup> (5)	Effective embedment $(h_{ef})^2$ (6)	Minimum no. of samples to be tested for each anchor size (7)	Other deviations from standard Installation and test conditions, if any (8)	Measurement and Assessment Checks (TS – Test Series) (9)	Test Applicable to (10)	Test Reference section (11)	Assessment option (12)
		Standard	0.3	Max	-	5	Installation as per 7.16 Unconfined test set up	For residual load test: Determine $N_{u,m}$ , $N_{u,5\%}$ and $v_F$ Check $v_F \leq 20\%$ & $v_\delta \leq 40\%$ Determine $\beta_{vF}$ <sup>(5)</sup> Determine $\alpha$ (using Ref TS 11) <sup>(5)</sup> ; $\alpha_{reqd}=0.9$ Assessment as per <b>8.2.2</b>	TCAA	<b>7.16</b>	B
35	Sensitivity to high alkalinity	Standard	0	M	30 mm	10	Installation as per 7.11	Assessment as per <b>8.2.2(h)</b>	AA, TCAA	<b>7.11</b>	B, C
36	Sensitivity to sulphurous atmosphere	Standard	0	M	30 mm	10	Installation as per 7.11	Assessment as per <b>8.2.2(h)</b>	AA, TCAA	<b>7.11</b>	B, C
37	Installation at freezing condition	Standard	0	12 mm	$7d_a$	5	Installation as per 7.12	Assessment as per <b>8.2.2(k)</b>	AA, TCAA	<b>7.12</b>	B, C
38	Sensitivity to reduced installation torque	Standard	0.3	All	-	10	Unconfined Dry concrete Anchors as per MPII but with reduced torque of 0.5Tinst (as per <b>6.6.14</b> )	Determine $N_{u,m}$ , $N_{u,5\%}$ and $v_F$ Check $v_F \leq 20\%$ Check $v_\delta$ <sup>(9)</sup> $\leq 40\%$ Determine $\beta_{vF}$ <sup>(8)</sup> Determine $\alpha$ (using Ref TS 7) Assessment as per <b>8.2.2</b> and <b>8.2.5</b>	TCAA	<b>7.4</b>	B
39	Slip force test	Standard	0.3	All	-	5		Assessment as per <b>8.2.2</b>	TCAA	<b>7.4</b>	B
40	Bond force test	Standard	0.3	All	-	5		Assessment as per <b>8.2.2</b>	TCAA	<b>7.4</b>	B
<b>Seismic tests</b>											
S1	Reference tension tests for seismic evaluation	Standard	0.8	All	$7d_a$	5	Confined for AA; Unconfined for TCAA	Determine $N_{u,m}$ , $N_{u,5\%}$ and $v_F$ $v_F < 20\%$ Determine $\beta_{vF}$ <sup>(5)</sup> Determine $\alpha$ (using Ref TS 5 for AA and Ref TS 14 for TCAA)	AA, TCAA	<b>7.4, 7.5</b>	A

Test Series No. (1)	Title (2)	Concrete Strength (3)	Crack width $\Delta w$ (mm) (4)	Anchor diameters to be tested <sup>(1)</sup> (5)	Effective embedment $(h_{ef})^2$ (6)	Minimum no. of samples to be tested for each anchor size (7)	Other deviations from standard Installation and test conditions, if any (8)	Measurement and Assessment Checks (TS – Test Series) (9)	Test Applicable to (10)	Test Reference section (11)	Assessment option (12)
								Assessment as per <b>8.4.2</b>			
S2	Reference tension tests for seismic evaluation	High	0.8	All	$7d_a$	5	Confined for AA; Unconfined for TCAA	Determine $N_{u,m}$ , $N_{u,5\%}$ and $v_F$ $v_F < 20\%$ Determine $\beta_{vF}$ <sup>(5)</sup> Determine $\alpha$ (using Ref TS 6 for AA and Ref TS 14 for TCAA) Assessment as per <b>8.4.2</b>	AA, TCAA	<b>7.4, 7.5</b>	A
S3	Shear test in large crack	Standard	0.8	All	$7d_a$	5		Determine $V_{u,m}$ , $V_{u,5\%}$ and $v_F$ $v_F < 15\%$ Determine $\beta_{vF}$ <sup>(5)</sup> Determine $\alpha$ (using Ref TS 17) Assessment as per <b>8.4.3</b>	AA, TCAA	<b>7.17</b>	A
S4	Tests for pulsating tension load	Standard	0.5 to 0.8	All	$7d_a$	5	Confined for AA; Unconfined for TCAA	For residual load test: Determine $N_{u,m}$ , $N_{u,5\%}$ and $v_F$ $v_F < 20\%$ Determine $\beta_{vF}$ <sup>(5)</sup> Determine $\alpha$ (using TS S1) Assessment as per <b>8.4.4</b>	AA, TCAA	<b>7.19</b>	A
S5	Tests for alternating shear load	Standard	0.8	All	$7d_a$	5		For residual load test: Determine $N_{u,m}$ , $N_{u,5\%}$ and $v_F$ $v_F < 15\%$ Determine $\beta_{vF}$ <sup>(5)</sup> Determine $\alpha$ (using TS S3) Assessment as per <b>8.4.5</b>	AA, TCAA	<b>7.20</b>	A
S6	Crack cycling test with large crack width	Standard	0.8	All	$7d_a$	5		For residual load test: Determine $N_{u,m}$ , $N_{u,5\%}$ and $v_F$ $v_F < 20\%$ Determine $\beta_{vF}$ <sup>(5)</sup>	AA, TCAA	<b>7.21</b>	A

Test Series No. (1)	Title (2)	Concrete Strength (3)	Crack width $\Delta w$ (mm) (4)	Anchor diameters to be tested <sup>(1)</sup> (5)	Effective embedment $(h_{ef})^2$ (6)	Minimum no. of samples to be tested for each anchor size (7)	Other deviations from standard Installation and test conditions, if any (8)	Measurement and Assessment Checks (TS – Test Series) (9)	Test Applicable to (10)	Test Reference section (11)	Assessment option (12)
								Determine $\alpha$ (using TS S1) Assessment as per <b>8.4.6</b>			

NOTES

1 A reduced range of anchor sizes indicated by S/M/L only shall be tested. The number of diameters to be tested in this case shall depend on the number of requested sizes and is given in the following tables. The tests shall be performed with single anchors except in the test series with anchor groups. In tests where it is recommended to test M diameter anchors, 12 mm or the smallest applicable size shall be used if the specimens being tested are larger than 12 mm. In static tension tests, steel failure shall be avoided. This may be achieved by using steel fastening element of higher grade for the test. If steel failure cannot be avoided even after increasing steel grade then embedment depth may be reduced.

No. of anchor sizes (diameter) requested for assessment by manufacturer	No. of diameters to be tested
Up to 5	3
6 to 8	4
9 to 11	5
> 11	6

- 2 Min and Max refer to minimum and maximum embedment recommended by manufacturer, respectively. The embedment depth value of  $7d_a$  and max may be reduced if steel failure occurs in test, except for test series 7. Alternatively, fastening element with higher steel grade may be used to avoid steel failure. For capsule type adhesive anchors, the embedment depth recommended by manufacturer shall be used instead of recommended embedment depth of  $7d_a$ . If only one embedment is recommended by the manufacturer then all tests shall be performed with that embedment.
- 3 Test in unconfined test are only required if characteristic bond strength is being calculated using  $\alpha_{setup}$  equal to 1.
- 4 The reference tests shall be performed in the same concrete batch as that of the test to which they will be compared
- 5 Repeated load test is optional for assessment as per Option 2.
- 6 This test shall only be required if the Test Series 3 has been carried out in a different concrete batch than the long term performance test.
- 7 This test may be omitted for adhesive anchors if the characteristic strength is determined using confined setup along with default values of  $\alpha_{setup}$  corresponding to confined test setup
- 8 If the coefficient of variation is higher than the limit defined for test series then the reduction factor  $\beta_{vF}$  shall be calculated according to **D-4** and applied to the characteristic value. The reduction  $\alpha$  shall also be calculated according to **D-5**.
- 9 In this case,  $v_\delta$  is the coefficient of variation of displacement corresponding to displacement at 50 percent of the mean ultimate failure load.

## 8 ASSESSMENT CRITERIA AND METHOD

### 8.1 General Procedure

The assessment method defined in this standard shall be used to assess mechanical strength and stability of post-installed adhesive anchors and torque controlled adhesive anchors. The assessment method given in this standard shall be applicable only to the following:

**8.1.1** Anchors of diameter greater than or equal to 6 mm.

**8.1.2** Anchors with embedment depth greater than maximum of 60 mm and  $4d_a$  but less than  $20d_a$ .

**8.1.3** Base material of thickness greater than  $2h_{ef}$  but not less than 100 mm, unless specified otherwise.

**8.1.4** Exposure to temperature range of  $-40^{\circ}\text{C}$  to  $T_{mst}/T_{mlt}$  during service life.

**8.1.5** Anchors for use in “uncracked” concrete only or “cracked and uncracked” concrete.

**8.1.6** Anchors subjected to static, quasi static or seismic conditions.

**8.1.7** Anchors with estimated service life of 50 years and 100 years, as applicable.

*Commentary – The actual service life of a product is dependent on the specific exposure condition, intended use, quality of installation, maintenance etc. This requirement on the service life is only a means of defining appropriate assessment procedure. It should not be interpreted as a guarantee given by the manufacturer or the approval body but regarded only as a means for expressing the expected economically reasonable working life of the anchor.. The assessment provisions in this standard are based on available knowledge and experience.*

**8.1.8** General Assessment Method given in Annex B shall apply.

**8.1.9** The results of assessment shall be reported in AR for design according to CED 02(25733). Sample format for AR is given in Annex C.

### 8.2 Method for Assessing Characteristic Resistance to Tension

#### 8.2.1 Resistance to Steel Failure

Resistance to steel failure shall be established by assessing results of Steel Capacity Test (Test Series 1) and Torque test (Test series 2).

- a) Determination of characteristic steel strength – The characteristic resistance to steel failure shall be calculated using the following equation. The smallest area of cross-section in area of load transfer shall apply.

$$N_{Rk,s} = A_s f_u$$

- 1) If the steel strength varies along the length of anchor then the steel capacity shall be calculated using the above equation for all such sections and the minimum value shall govern.
- 2) If it is not possible to establish distribution of steel strength along the length of the anchor then steel capacity test shall be performed in accordance with Steel Capacity Test (Test Series 1) to determine the characteristic resistance. The

modulus of elasticity may be taken as per structural properties of material of the anchor.

- 3) The 5<sup>th</sup> percentile determined from the tests shall be normalized as per Annex B to specified steel strength to account for over strength. In this case, the normalized 5<sup>th</sup> percentile value shall be taken as the characteristic value.
- b) Verification of installation torque – The mean value of the tension force and 95<sup>th</sup> percentile of the tension force at  $1.3T_{inst}$  shall be determined after completion of the test. It shall be established that the installation torque recommended by manufacturer will not result in steel failure of bolt during application. To establish this parameter tests shall be performed in accordance with “Maximum Installation Torque Moment Test” (Test Series 2). The following criteria shall be fulfilled: -
  - 1) The 95th percentile of the pre-stressing tension force generated in torque tests at an installation torque moment  $T$  equal to 1.3 times  $\max T_{inst}$  for adhesive anchors and 1.3 times  $T_{inst}$  for torque-controlled adhesive anchors, shall be smaller than the nominal yield force ( $A_s f_y$ ) of the embedded anchor.
  - 2) The 95th percentile of the pre-stressing tension force generated in torque tests at an installation torque moment  $T$  equal to 1.3 times  $\max T_{inst}$  for adhesive anchors and 1.3 times  $T_{inst}$  for torque-controlled adhesive anchors, shall be smaller than the characteristic pullout strength ( $N_{Rk,p}$ ) corresponding to minimum embedment given by  $(\pi \cdot \tau_{Rk,uncr'} \cdot d_a \cdot h_{ef,min})$ .
  - 3) The tension force generated in the torque test shall be less than the concrete cone capacity determined according to CED 02(25733).
  - 4) The connection should be capable of being un-torqued (or unscrewed) after completion of the test.
  - 5) The tension force generated in the torque test shall be less than the concrete cone capacity corresponding to 25 MPa uncracked concrete determined according to CED 02(25733), for minimum embedment depth.
  - 6) The connection should be capable of being un-torqued after completion of the test.

### 8.2.2 Resistance to Pull-out Failure

The tests are performed to determine the tension capacity of a single anchor without edge influence. The following assessment criteria shall apply to these tests.

- a) Assessment of ultimate failure load
  - 1) The mean ultimate failure load and the 5<sup>th</sup> percentile value (see **B-2**) of all test series shall be converted to nominal concrete strength as per **B-1** depending on failure type (also see Table 1), taking into account influence of concrete batch as per **B-5**. The normalized values shall be used for calculating reduction factors.

NOTE – If mixed failure types occur in a test series then the normalization shall be performed assuming the failure type which was observed in majority of tests in that test series.

- 2) The coefficient of variation of the test series shall be determined. It shall be less than 15% for reference test and 20% for other tests. If the coefficient of



variation is higher than the limit defined for corresponding test series then the reduction factor  $\beta_{vF}$  shall be calculated according to **B-6**.

- 3) The reduction factor  $\alpha$  for the test series (except for reference tests) shall be calculated according to **B-8** using corresponding reference test as mentioned in Table 2 for each test series.
- 4) The ratio  $\alpha/\alpha_{reqd}$  shall be then determined using the calculated  $\alpha$  factor and the  $\alpha_{reqd}$  factor recommended in Table 2 for each test series. If all anchor diameters have not been tested then the smallest reduction factor  $\alpha$  shall apply for other diameters as well for that test series.
- 5) If the requirements on uncontrolled slip are not fulfilled, then the reduction factor  $\alpha_1$  and the ratio  $\alpha_1/\alpha_{1,reqd}$  shall be calculated according to **B-9**.

#### NOTES

**1** When comparing to tests, it shall be permitted to normalize the results to concrete strength corresponding to reference test.

**2** It is not permitted to reduce the characteristic value if the requirement is not met. The test need to be repeated with longer curing duration until the requirement is met.

- b) Assessment of load-displacement behavior – The load-displacement curves shall be examined for indication of uncontrolled slip according to **B-9**. The displacement at 50% of the mean ultimate failure load (for each test of test series) along with its corresponding coefficient of variation of displacement shall be determined. If the displacements at 50% of the mean ultimate failure load are larger than 0.4 mm then the coefficient of variation of displacement corresponding to displacement at 50% of the mean ultimate failure load shall not exceed 25% for reference tension tests as well as temperature tests and 40% for other tests (see **B-10**), except when noted otherwise in Table 2.

- 1) For the slip force test of torque controlled adhesive anchors, the mean slip force  $N_{slip,m}$  and 95<sup>th</sup> percentile of the slip ( $N_{slip,95\%}$ ) force shall be determined.
- 2) For the bond force test of torque controlled adhesive anchors, the load at loss of adhesion shall be carried out in accordance with **B-9**. The mean bond force  $N_{bond,m}$  and 5<sup>th</sup> percentile of the bond force ( $N_{bond,5\%}$ ) shall be determined.

One of the following conditions must be satisfied –

1.  $N_{bond,m}/N_{slip,m} \geq 3$
2.  $N_{bond,5\%}/N_{slip,95\%} \geq 1.3$

This is applicable if the coefficient of variation of ultimate loads is less than or equal to 15% for Test Series 39 and less than or equal to 10% for Test Series 40.

NOTE – In case of torque-controlled adhesive anchors in cracked concrete, a short plateau (max length of plateau – 0.5 mm) along with minor load drop may be observed in load-displacement curves. This indicates the point when the

adhesion between bonding material and fastening element is destroyed. This is acceptable and shall not be interpreted as uncontrolled slip.

- c) Additional requirements on load-displacement behavior of specific test series
- 1) The ultimate load of reference test in high strength concrete (Test series 4 and 6) shall not be less than the corresponding test in standard concrete (Test series 3 and 5).
  - 2) Similar provisions apply for the basic tension test with unconfined test set up (Test Series 11 to 14).
  - 3) For assessing the sensitivity to increased temperature (Test Series 20 and 21), the factor  $\alpha_2$  and  $\alpha_3$  for test at maximum long term (MLT) and maximum short term temperature (MST), respectively shall be determined using the following equations. For temperature range (a) as defined in 7.7.4, the results of tests at ambient temperature may be taken for MLT evaluation.

$$\alpha_2 = \min \left( \frac{N_{u,m,mlt}}{N_{u,m,r}}; \frac{N_{5\%,mlt}}{N_{5\%,r}} \right) \leq 1$$

$$\alpha_3 = \min \left( \frac{N_{u,m,mst}}{0.8N_{u,m,mlt}}; \frac{N_{5\%,mst}}{0.8N_{5\%,mlt}} \right) \leq 1$$

- d) The following shall apply for assessing Test Series 22 (Minimum curing time test at minimum installation temperature): - The mean ultimate load and 5<sup>th</sup> percentile load measured in tests at the minimum installation temperature shall be at least equal to the corresponding values measured in tests at ambient temperature and corresponding minimum curing time. If the required test condition is not fulfilled, then the minimum curing time at the minimum installation temperature shall be increased and the tests at minimum installation temperature shall be repeated until the condition is fulfilled.
- e) The following shall apply for assessing Test Series 23 (Minimum curing time test at ambient temperature):- The mean ultimate load and the 5<sup>th</sup> percentile load measured in tests at the standard ambient temperature and corresponding minimum curing time shall be at least 0.9 times the corresponding value measured in reference tests with a "long curing time" (24 hours for resins and 14 days for cementitious mortars). If this condition is not fulfilled, then the minimum curing time at standard ambient temperature shall be increased and the tests shall be repeated with revised curing time.

The comparison of characteristic load shall not be considered for evaluation in test series mentioned in **8.2.2 (c) to (e)** if: -

- 1) the coefficient of variation of the test series is smaller than or equal to the coefficient of variation of the reference test series or
- 2) the coefficient of variation of ultimate loads is less than or equal to 15% in both test series.

The residual tension load test shall be assessed according to **8.2.2(a)** and **8.2.2(b)**.

- f) For repeated load test (Test Series 28), the increase in anchor displacements when subjected to repeated load cycle shall stabilize during cycling in a manner such that application of some additional cycles shall not cause failure. No failure shall occur

during the repeated load cycles. If these requirements are not met then the tension loads for repeated cycles shall be calculated with reduced characteristic strength and the tests shall be repeated until these requirements are not met. In this case, a reduction factor  $\alpha_p$  shall be calculated as a ratio of the reduced characteristic strength to the maximum load on the anchor imposed for repeated load cycles as per **B-7**. The residual tension load test shall be assessed according to **8.2.2(a)** and **8.2.2(b)**. The above assessment is applicable for adhesive anchors for a working life of 50 years when the number of load cycles is  $10^5$  and 100 years for  $2 \times 10^5$  load cycles.

- g) For assessing the sensitivity to crack cycling (Test Series 30), the rate of increase of anchor displacement in crack cycling tests shall either decrease or be almost constant when plotted in a half-logarithmic scale (see Fig 19).

NOTE – The displacements may be considered to be stabilized if the increase of displacements during cycle no. 750 to 1000 is smaller than the displacement recorded during cycle no. 500 to 750.

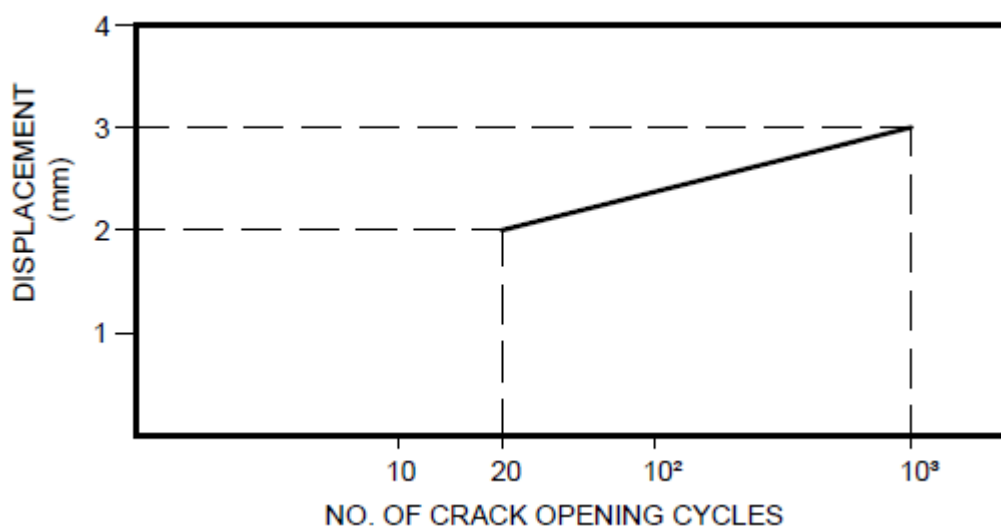

FIG. 19 CRITERIA FOR RESULTS OF TESTS WITH INDUCED CRACKS

The criteria of the allowable displacement  $\delta_{20}$  after 20 cycles (applicable for both 50 and 100 years assessment) and  $\delta_{1000}$  after 1000 cycles (applicable for 50 years assessment) and  $\delta_{2000}$  after 2000 cycles (applicable for 100 years assessment) of crack opening shall be graduated as a function of the number of tests as per Table 6.

**Table 6 Limit for Allowable Displacement for Crack Cycling Test  
(as per Option B)**

[Clause 8.2.2(g)]

Number of tests	Limits for allowable displacement depending on no. of samples tested
5 to 9	$\delta_{20} \leq 2$ mm $\delta_{1000} \leq 3$ mm
10 to 20	$\delta_{20} \leq 2$ mm; one test is allowed up to 3 mm $\delta_{1000} \leq 3$ mm; one test is allowed to up to 4 mm
> 20 tests	$\delta_{20} \leq 2$ mm; 5% of tests are allowed to 3 mm $\delta_{1000} \leq 3$ mm; 5% of tests are allowed to 4 mm

If these requirements w.r.t to stabilization of displacement and allowable displacement are not met then the crack cycle test shall be repeated with reduced sustained tension load on the anchor. In this case, a reduction factor  $\alpha_p$  shall be calculated as a ratio of the reduced load to the actual sustained load  $N_{sus}$  applied on the anchor during crack cycles as per **B-7**. The residual tension load test shall be assessed according to **8.2.2(a)** and **8.2.2(b)**.

- h) For evaluating durability according to slice test (Test Series 10, 35 and 36), it shall be shown that the bond strength of the slices stored in alkaline liquid ( $\tau_{um,ts35}$ ) is at least as high as that of the bond strength of the reference tests on slices stored under standard conditions ( $\tau_{um,ts10}$ ). The bond strength of the slices stored in sulphurous atmosphere media ( $\tau_{um,ts36}$ ) is at least 90% of the bond strength of the reference tests on slices stored under standard conditions ( $\tau_{um,ts10}$ ). If the following equation for factor  $\alpha_4$  is fulfilled then this requirement shall be considered satisfied.

$$\alpha_4 = \left( \frac{\tau_{um,ts35}}{\tau_{um,ts10}}; \frac{\tau_{um,ts36}}{0.9\tau_{um,ts10}} \right) \leq 1$$

Where,

$$\tau_{u,m} = N_{u,ts} / (\pi d_a D_{sl})$$

$D_{sl}$  = Measured thickness of slice

- j) For sustained load tests (Test Series 31 and 32), the increase in displacement of anchor during sustained load test shall reduce with time in a manner which indicates that failure is unlikely to occur in its design life. The displacements measured in the tests shall be extrapolated according to the following equation as per Findley approach to 50 years for tests at ambient temperature or 10 years for tests at maximum long term temperature. The trend line according to following equation shall be constructed with data from not less than the last 20 days and not less than 20 data points of the sustained load test.

For assessment against 100 years of working life, the displacement measured in test have to be extrapolated according to the same equation to 100 years for tests at ambient temperature or 20 years for tests at maximum long term temperature. The trend line according to the following equation shall be constructed with data covering at least the final 70% of the time under sustained loading.

The extrapolated displacements shall be less than the average value of the displacements  $\delta_{u,adh}$  in the corresponding reference tests at standard ambient temperature or maximum long term temperature respectively.  $\delta_{u,adh}$  is the displacement at  $N_{u,adh}$  (see **B-9**).

$$\delta(t) = \delta_0 + x \cdot t^y$$

where

$\delta_0$  = Initial displacement under the sustained load at  $t = 0$ ; this value shall be measured directly after applying the sustained load

x, y = Constants (tuning factors); evaluated by a regression analysis of the deformations measured during the sustained load tests

t = Time

If the test criteria are not fulfilled then the test shall be repeated with reduced sustained tension load or reduced temperature. In this case, a reduction factor  $\alpha_p$  shall be calculated.

The factor  $\Psi_{sus}^0$  due to the influence of sustained load on the bond strength of the adhesive anchor shall be calculated for every temperature range requested by the manufacturer for a working of 50 years as follows -

$$\Psi_{sus}^0 = 1.15 \cdot \frac{\tau'_{Rk,uncr,t}}{\tau_{Rk,uncr,t}} \leq 1.0$$

$\tau'_{Rk,uncr,t}$  = Basic characteristic long term bond strength at maximum long term temperature for uncracked concrete for the corresponding temperature range

$\tau_{Rk,uncr,t}$  = Characteristic short term bond strength at maximum short term temperature for uncracked concrete for the corresponding temperature range as per AR

$$\tau'_{Rk,uncr,t} = \tau_{sus} \cdot \alpha_3 \cdot \alpha_4 \cdot k_{sus} \cdot \alpha_{setup} \cdot \min(\beta_{vF})$$

$$\tau_{sus} = \frac{N_{sus}}{\pi d_a h_{ef}} \cdot \min\left(1; \frac{\alpha}{0.9}\right)$$

$\alpha$  = Reduction factor for test series 31 or 32

$N_{sus}$  = Sustained load applied at MLT, which meet the criteria, normalized to M25 concrete

$\alpha_{setup}$  = 0.75, reduction factor for uncracked concrete

$\alpha_3$  = Reduction factor according to section 8.2.2 (c) (maximum short term temperature)

$\alpha_4$  = Reduction factor according to section 8.2.2 (h) (durability)

$k_{sus}$  = 1,135, Factor to take into consideration beneficial effects under long term loading

$\alpha_{setup}$  = 0.75, reduction factor for confined test setup for uncracked concrete

k) For Freeze-Thaw test (Test Series 33), the rate of increase of displacement shall reduce with increase in number of freeze/thaw cycles to a value almost equal to zero. If the test criteria are not fulfilled then the test shall be repeated with reduced sustained tension load. In this case, a reduction factor  $\alpha_p$  shall be calculated.

m) For assessing the performance for installation at freezing conditions (installation temperature equal or less than 0°C) (Test series 37), the displacements measured in the standard test (96 hours) shall stabilize within 150 hours from start of the temperature rise. In case displacements do not stabilize the test may be repeated with modified parameters e.g., reduced sustained load or increased minimum installation temperature. If the test is repeated with reduced sustained load the reduction factor  $\alpha_p$  shall be calculated.

In case the MPII allows a temperature variation within 12 hours from a low installation temperature (equal or less than 0 °C) to temperature equal or higher than 24°C tests to check the rapid variation of temperature (42 days) shall be performed.

Determine the displacement after 42 days for assessment of Test Series 37 and of Test Series 31.

Following condition shall be satisfied for rapid variation of temperature:

$$\delta_{N\infty,m} \leq \delta_{u,adh,m} - (\delta_{dt,42d,m} - \delta_{sust,42d,m})$$

where

$\delta_{N\infty,m}$  = Mean value of the extrapolated displacements in the sustained load test at normal ambient temperature (test series 31)

$\delta_{u,adh,m}$  = Mean displacement in the tension tests at loss of adhesion according to section B-9

$\delta_{dt,42d,m}$  = Mean displacement in the sustained load tests for rapid variation of temperature at 42 days (test series 37)

$\delta_{sust,42d,m}$  = Mean displacement measured in the sustained load test at normal ambient temperature at 42 days (test series 31)

### 8.2.3 Determination of Characteristic Pull-Out Strength

The characteristic bond strength ( $\tau_{Rk}$ ) in tension for cracked and uncracked concrete shall be determined as follows.

$$\tau_{Rk} = \tau_{5\%} \cdot \alpha_{setup} \cdot \min(\alpha_p) \cdot \min(\alpha_1 \cdot \min(\alpha/\alpha_{reqd})) \alpha_2 \cdot \alpha_3 \cdot \alpha_4 \cdot \min(\beta_{vF})$$

For torque controlled adhesive anchors,

$$N_{Rk,p} = N_{5\%} \cdot \alpha_{setup} \cdot \min(\alpha_p) \cdot \min(\alpha_1 \cdot \min(\alpha/\alpha_{reqd})) \alpha_2 \cdot \alpha_3 \cdot \alpha_4 \cdot \min(\beta_{vF})$$

The basic characteristic strength shall be based on reference tests with confined test setup (Test Series 3 to 6) or unconfined test set-up (Test Series 11 to 14)

If the basic characteristic bond strength is based on confined reference test then assume  $\alpha_{setup}$  equal to 0.75 for tests in uncracked concrete (Test Series 3 and 4) and 0.7 for tests in cracked concrete (Test Series 5 and 6).

If the basic characteristic bond strength is based on unconfined reference test (Test Series 11 to 14) then assume  $\alpha_{setup}$  equal to 1.

NOTE - Concrete cone failure may occur at minimum embedment in these tests for unconfined set-up. In addition to the minimum embedment depth, it is advised to select embedment depths such that pull-out failure occurs.

The concrete factor  $\Psi_c$  may be used to express the bond strength corresponding to different concrete grades.

NOTE – As per test data if it is established that the bond strength varies in a defined manner with respect to anchor diameter then the characteristic bond strength values may be evaluated as a function of anchor diameter.

### 8.2.4 Resistance to Concrete Cone Failure

The concrete cone strength shall be calculated according to CED 02(25733).

NOTE - No additional test and assessment shall be required to establish concrete cone strength when the design method given in CED 02(25733) is used.

### 8.2.5 Partial Safety Factor for Installation

For anchors installed in accordance with **6.6.13**, Table 7 shall be referred for  $\alpha_{reqd}$  values. The calculated  $\alpha$  factor shall be used to determine installation safety factor according to Table 3. For example, if the calculated  $\alpha$  is 0.75 for Test Series 24 then the  $\gamma_{inst}$  factor shall be taken as 1.4. The largest value of  $\gamma_{inst}$  obtained from all test series shall govern. If for any of the Test Series 24 to 27, and 38  $\alpha$  is less than the value corresponding to  $\gamma_{inst} = 1.4$  then the calculated  $\alpha$  value and  $\alpha_{reqd}$  value of 0.7 shall be used to determine the ratio  $\alpha/\alpha_{reqd}$ . This ratio  $\alpha/\alpha_{reqd}$  shall also be used in evaluation of characteristic bond strength as per **8.2.3** and the  $\gamma_{inst}$  shall be taken as 1.4.

**Table 7 Values of Req.  $\alpha$  in the Installation Safety Tests**  
(Clause 8.2.5)

Partial safety factor $\gamma_{inst}$ (1)	$\alpha_{reqd}$ for Test Series 24, 27, 38 (2)	$\alpha_{reqd}$ for Test Series 25, 26 (3)
1.0	$\geq 0.95$	$\geq 0.90$
1.2	$\geq 0.8$	$\geq 0.75$
1.4	$\geq 0.7$	$\geq 0.65$

**8.2.6** To determine permissible minimum edge and spacing (Test Series 19), tests shall be performed according to **7.6** on double anchor group. The characteristic torque moment,  $T_{Rk}$ , shall be determined from the test results according to **B-3**.

The characteristic torque moment determined from test shall fulfill the following equation in case of concrete failure.

*Commentary - The partial safety factor  $k_1$  is based on whether or not the scatter of the friction coefficients (between nut and washer), which determine the magnitude of the splitting forces at the required torque (req.  $T_{inst}$ ) is controlled during production to the values corresponding to the anchors used in the approval tests. The choice between the two shall be indicated in the Factory Production Control program.*

NOTE – If steel failure occurs, this check is not required as increase in edge distance and spacing will not affect the failure type. The tested edge distance and spacing shall be accepted.

$$T_{Rk} \geq k_1 T_{inst} \left( \frac{f_{ck}}{f_{c,ts}} \right)^{0.5}$$

**Table 8 Values of  $k_1$**   
(Clause 8.2.6)

Scatter of the friction coefficients (between nut and washer)	$k_1$	
	Anchors in uncracked concrete	Anchors in cracked concrete
Controlled during production	1.7	1.3
Not controlled during production	2.1	1.5

If the minimum edge and spacing value recommended by manufacturer does not fulfill the test requirement then the edge distance and spacing may be increased without repeating the test based on following assessment.

Step 1: Calculated projected splitting area  $A_{sp,t} = (3c'_{min} + s'_{min})(1.5c'_{min} + h_{ef})$

Step 2: Determine  $k_1$  from Table 4 based on test data

Step 3: Calculate  $A_{sp}$  with increased value of  $c'_{min}$  and  $s'_{min}$  till the following condition is fulfilled.

$$A_{sp} > reqd. k_1 / (k A_{sp,t})$$

**8.2.7** The critical splitting edge distance ( $c'_{cr,sp}$ ) shall be determined from Test Series 15. The critical spacing ( $s'_{cr,sp}$ ) shall be taken as twice the critical splitting edge distance. The mean bond strength of anchors at the corner shall be statistically equivalent as that of reference tension test (Test Series 3) when normalized for the same concrete strength. If this condition is not fulfilled, then the tests shall be repeated with larger edge distance.

NOTE - If the critical splitting edge distance is found to be smaller than or equal to  $c'_{cr,N}$ , then the calculation of the splitting strength may be neglected in the design of anchorages. This should be explicitly mentioned in AR.

### 8.2.8 Displacement under Static and Quasi-Static Loading

a) Displacements under short term tension - The displacements under short term tension ( $\delta_{N0}$ ) shall be evaluated from the reference tension tests on single anchors (Test Series 3 to 6), depending on assessment option selected. The maximum displacement value corresponding to load F calculated according to the following equation, shall be noted for each test series. The values shall correspond to 95<sup>th</sup> percentile. The maximum displacement value obtained in the test series shall govern.

$$F = \frac{F_{Rk}}{1.4\gamma_M}$$

where

$F_{Rk}$  = Characteristic strength evaluated based on all tests for a given load direction (Tension or shear)

$\gamma_M$  = Material partial safety factor according to CED 02(25733) for the corresponding failure mode



b) *Displacements under long term tension*

- 1) For assessment according to Option B, the displacements under long term tension loading ( $\delta_{N\infty}$ ), shall be evaluated from crack cycling tests (Test Series 30) using the following equation.

$$\delta_{N\infty} = \delta_{m1} / 1.5$$

where

$$\delta_{m1} = \text{Average anchor displacement after 1000 crack cycles.}$$

- 2) For assessment according to Option C, the displacements under long term tension loading ( $\delta_{N\infty}$ ) shall be evaluated from sustained load tests (Test Series 31 and 32) using the following equation.

$$\delta_{N\infty} = \delta_{m2} / 2.0$$

where

$$\delta_{m2} = \text{Displacement corresponding to the sustained load tests.}$$

### 8.3 Method for Assessing Strength of Anchor in Shear

#### 8.3.1 Determination of Characteristic Strength of Single Anchor in case of Steel Failure

Steel strength of anchors with uniform strength along length of anchor shall be calculated according to CED 02(25733) and provided in AR.

Steel strength of anchors with non-uniform strength or significantly reduced cross section along length of anchor shall be evaluated based on results of shear test (Test Series 17).

The mean ultimate load, 5<sup>th</sup> percentile of load and coefficient of variation shall be determined.  $V_{Rk,s}^0$  shall be taken as 5<sup>th</sup> percentile of ultimate load after normalization. The characteristic load determined from shear test shall be used.

The characteristic resistance of a group of anchors in case of steel failure is influenced by the ductility of the anchor. The influence factor  $k_1$  [7.2.3.10 of CED 02(25733)] may be taken from the AR of the anchor based on manufacturer recommendation. The commonly acceptable value is 1.0 for rupture elongation > 8% and 0.8 for rupture elongation ≤ 8%.

#### 8.3.2 Concrete Pry-out Strength

The assessment of performance of a post installed mechanical anchor against concrete pry-out test shall be carried in accordance with Test Series 18.

The value of  $k_{cp}$  shall be obtained from the respective AR.

#### 8.3.3 Concrete Edge Strength

The concrete edge strength shall be calculated according to CED 02(25733). The effective length of anchor for transfer of shear shall be provided in the AR.

NOTE - No additional test and assessment shall be required to establish concrete edge strength when the design method given in CED 02(25733) is used.

#### 8.3.4 Displacement under static and quasi-static loading

a) Displacements under short term shear loading ( $\delta_{V0}$ ) shall be evaluated from the shear tests on single anchors (Test Series 17). The displacement value corresponding to load  $F$  calculated according to the equation in **8.2.8 (a)** shall be noted for each test series. The maximum displacement value obtained shall govern.

NOTE - It should be sufficient to give one value each for the short term tension and short term shear displacement. This value should represent the most unfavorable condition and should be valid for all concrete strength classes and state of concrete (cracked/uncracked).

b) Displacements under long term shear loading ( $\delta_{V\infty}$ ) shall be assumed to be equal to 1.5 times the displacements under short term shear loading ( $\delta_{V0}$ ).

NOTE – The load at which the first slip occurs cannot be ensured in long term because of the influence of shrinkage and creep of the concrete, crack formation etc.

#### 8.4 Method for Assessing Characteristic Strength When Subjected to Seismic Conditions

**8.4.1** The reduction factor shall be calculated as per **B-6** and this section. The load-displacement scatter requirement shall be as per **B-10** and this section. In case of conflict, the requirement of this section shall be applicable. In case the load-displacement behavior requirements are not met, it shall be permitted to increase the no. of tests to meet the requirements.

##### 8.4.2 Assessment of Test Series S1 and S2

The mean ultimate load and 5<sup>th</sup> percentile of ultimate load shall be determined. The coefficient of variation shall also be determined.

a) Assessment of ultimate failure load of Test Series S1 and S2 – The reduction factor for each test series shall be determined as follows. Prior to comparison of results of both test series, the load values shall be normalized to 25 MPa concrete strength, depending on the failure type observed in the test series.

Reduction factor for Test Series S1:

$$\alpha_{ts\_S1} = \begin{cases} 1 & \text{if } N_{u,m,ts\_S1} \geq 0.8N_{u,m,cr',ts8} \\ N_{u,m,ts\_S1}/0.8N_{u,m,cr',ts8} & \text{if } N_{u,m,ts\_S1} < 0.8N_{u,m,cr',ts8} \end{cases}$$

Reduction factor for Test Series S2:

$$\alpha_{ts\_S2} = \begin{cases} 1 & \text{if } N_{u,m,ts\_S2} \geq 0.8N_{u,m,cr',ts9} \\ N_{u,m,ts\_S2}/0.8N_{u,m,cr',ts9} & \text{if } N_{u,m,ts\_S2} < 0.8N_{u,m,cr',ts9} \end{cases}$$

For torque controlled adhesive anchors, reference to Test Series 29 for standard cracked concrete shall be made.

b) The scatter of ultimate failure load of Test Series S1 and S2 shall be assessed as per **8.2.2 (a) (2)**. The minimum of the two  $\beta_{VF}$  values shall govern. If the coefficient of variation is higher than 30% then the anchor shall be deemed unsuitable for use in seismic situation. It shall be permitted to increase no. of tests in the test series to fulfill the limit for coefficient of variation.

- c) The load-displacement behavior of Test Series S1 and S2 shall be assessed as per **8.2.2(b)**. If this condition is not met then the anchors shall be deemed unsuitable for use in seismic conditions.

NOTE – This requirement is not applicable if this displacement (i.e., at 50% of the mean ultimate failure load) is less than or equal to 0.4 mm.

- d) The final reduction factor of Test Series S1 and S2 shall be calculated as follows.

$$\alpha_{ts\_S1,S2} = \min (\alpha_{ts\_S1}; \alpha_{ts\_S2})$$

#### 8.4.3 Assessment of Test Series S3

The mean ultimate load and 5<sup>th</sup> percentile of ultimate load shall be determined. The coefficient of variation shall also be determined.

- a) Assessment of ultimate failure load of Test Series S3 – The reduction factor shall be determined as follows. Prior to comparison of results of both test series, the load values shall be normalized to 25 MPa concrete strength, depending on the failure type observed in the test series. If pull-out or pull-through failure occurs in this test series, the anchor shall be deemed unsuitable for use in seismic conditions. It shall be permitted to test with larger embedment to avoid pull-out or pull-through failure.

$$\alpha_{ts\_S3} = \begin{cases} 1 & \text{if } V_{u,m,ts\_S3} \geq 0.8V_{u,m,uncr,ts20} \\ V_{u,m,ts\_S3}/0.8V_{u,m,uncr,ts20} & \text{if } V_{u,m,ts\_S3} < 0.8V_{u,m,uncr,ts20} \end{cases}$$

- c) The scatter of ultimate failure load of Test Series S3 shall be assessed as per **8.2.2(a)(2)**. If the coefficient of variation is higher than 30% then the anchor shall be deemed unsuitable for use in seismic situation.

#### 8.4.4 Assessment of Test Series S4

The mean ultimate load and 5<sup>th</sup> percentile of ultimate load shall be determined. The coefficient of variation shall also be determined.

- a) Assessment of pulsating tension load cycle

- 1) If the anchor fails to develop required resistance in any of the tension load cycles prior to completion of all cycles, then the test shall be recorded as unsuccessful and the test shall be repeated with reduced  $N_{max}$  ( $N_{max, reduced}$ ), i.e., maximum load of tension load cycle, until the anchor successfully completes the load cycle. In this case, the reduction factor  $\alpha_{ts\_S4}$  shall be calculated as follows.

$$\alpha_{ts\_S4} = (N_{max, reduced})/N_{max}$$

- 2) The anchor displacements shall be assessed for the last load cycle corresponding to load value  $0.5 N/N_{max}$  and  $1.0 N/N_{max}$ . If the  $N_{max}$  is reduced then the revised value of  $N_{max}$  (that is,  $N_{max, reduced}$ ) shall be used to determine the corresponding load value at which displacements shall be assessed. Mean of the displacements measured at both load values shall be recorded after the anchor successfully completes the load cycle. The mean displacement corresponding to  $0.5 N/N_{max}$  or  $0.5 N/(N_{max, reduced})$  shall be less than 7 mm. If this displacement limit is not met then the tests shall be repeated with further reduced “maximum load of tension cycle” and  $\alpha_{ts\_S4}$  shall

be recalculated with this reduced load value. Minimum of the  $\alpha_{ts\_S4'}$  value calculated as per **8.4.4(a) (1)** and **(2)** shall be used.

b) Assessment of residual load test of Test Series S4

- 1) Assessment of ultimate failure load of Test Series S4 – The reduction factor shall be determined as follows. Prior to comparison of results of both test series, the load values shall be normalized to 25 MPa concrete strength, depending on the failure type observed in the test series. Alternatively, the results of Test Series S1 may be normalized to that of S4.

$$\alpha_{ts\_S4''} = \begin{cases} 1 & \text{if } N_{u,m,ts\_S4} \geq 0.9N_{u,m,ts\_S1} \\ N_{u,m,ts\_S4}/0.9N_{u,m,ts\_S1} & \text{if } N_{u,m,ts\_S4} < 0.9N_{u,m,ts\_S1} \end{cases}$$

NOTE – Instead of calculating, it may also be permitted to repeat pulsating tension load cycle with further reduced value of  $N_{max}$  to fulfill the above requirement.

- 2) The scatter of ultimate failure load of Test Series S4 shall be assessed as per **8.2.2(a)(2)**. If the coefficient of variation is higher than 30% then the anchor shall be deemed unsuitable for use in seismic situation.
- 3) The load-displacement behavior of Test Series S4 shall be assessed as per **8.2.2(b)**. If this condition is not met then the anchors shall be deemed unsuitable for use in seismic conditions.

NOTE – This requirement is not applicable if this displacement (that is, at 50 percent of the mean ultimate failure load) is less than or equal to 0.4 mm.

- 4) The final reduction factor of Test Series S4 shall be calculated as follows.

$$\alpha_{ts\_S4} = \alpha_{ts\_S4'} * \alpha_{ts\_S4''}$$

#### 8.4.5 Assessment of Test Series S5

The mean ultimate load and 5<sup>th</sup> percentile of ultimate load shall be determined. The coefficient of variation shall also be determined.

a) Assessment of alternating shear test

- 1) If the anchor fails to develop required resistance in any of the shear load cycles prior to completion of all cycles, then the test shall be recorded as unsuccessful and the test shall be repeated with reduced  $V_{max}$  ( $V_{max, reduced}$ ), i.e., maximum load of shear load cycle, until the anchor successfully completes the load cycle. In this case, the reduction factor  $\alpha_{ts\_S5'}$  shall be calculated as follows.

$$\alpha_{ts\_S5'} = (V_{max, reduced})/V_{max}$$

- 2) The anchor displacements shall be assessed for the last load cycle corresponding to load value  $\pm 0.5V/V_{max}$  and  $\pm 1.0V/V_{max}$ . If the  $V_{max}$  is reduced then the revised value of  $V_{max}$  (*that is,  $V_{max, reduced}$* ) shall be used to determine the corresponding load value at which displacements shall be assessed. After the anchor successfully completes the load cycle, displacements measured at both load values shall be recorded as the

maximum of mean of absolute displacement values in positive and in negative load direction for each load value (i.e.,  $\pm 0.5 V/V_{max}$  and  $\pm 1.0 V/V_{max}$ ). The mean displacement corresponding to  $\pm 0.5 V/V_{max}$  or  $\pm 0.5 V/(V_{max, reduced})$  shall be less than 7 mm. If this displacement limit is not met then the tests shall be repeated with further reduced “maximum load of shear cycle” and  $\alpha_{ts\_S5}$ , shall be recalculated with this reduced load value. Minimum of the  $\alpha_{ts\_S5}$ , value calculated as per **8.4.5(a)(1)** and **(2)** shall be used.

b) Assessment of residual load test of Test Series S5

1) Assessment of ultimate failure load of Test Series S5 – The reduction factor shall be determined as follows. Prior to comparison of results of both test series, the load values shall be normalized to 25 MPa concrete strength, depending on the failure type observed in the test series. Alternatively, the results of Test Series S3 may be normalized to that of S5. If pull-out or pull-through failure occurs in this test series, the anchor shall be deemed unsuitable for use in seismic conditions. It shall be permitted to test with larger embedment to avoid pull-out or pull-through failure.

$$\alpha_{ts\_S5''} = \begin{cases} 1 & \text{if } V_{u,m,ts\_S5} \geq 0.95V_{u,m,ts\_S3} \\ V_{u,m,ts\_S5}/0.95V_{u,m,ts\_S3} & \text{if } V_{u,m,ts\_S5} < 0.95V_{u,m,ts\_S3} \end{cases}$$

NOTE – Instead of calculating, it may also be permitted to repeat alternating shear load cycle with further reduced value of  $V_{max}$  to fulfill the above requirement.

2) The load-displacement behavior of Test Series S4 shall be assessed as per **8.2.2(b)**. If this condition is not met then the anchors shall be deemed unsuitable for use in seismic conditions.

3) The final reduction factor of Test Series S5 shall be calculated as follows.

$$\alpha_{ts\_S5} = \alpha_{ts\_S5'} * \alpha_{ts\_S5''}$$

#### 8.4.6 Assessment of Test Series S6

The mean ultimate load and 5<sup>th</sup> percentile of ultimate load shall be determined. The coefficient of variation shall also be determined.

a) Assessment of pulsating tension load cycle

1) If the anchor fails to develop required resistance in any of the cycles prior to completion of all crack cycles, then the test shall be recorded as unsuccessful and the test shall be repeated with proportionally reduced values of  $N_{w1}$  ( $N_{w1, reduced}$ ) and  $N_{w2}$  ( $N_{w2, reduced}$ ), that is, maximum sustained load the anchor is subjected to during crack cycle, until the anchor successfully completes the crack cycle. In this case, the reduction factor  $\alpha_{ts\_S6'}$ , shall be calculated as follows.

$$\alpha_{ts\_S6'} = (N_{w2, reduced})/N_{w2}$$

2) The anchor displacements shall be assessed for the last load cycle corresponding to crack width  $\Delta w = 0.5 \text{ mm}$  and  $\Delta w = 0.8 \text{ mm}$ . Mean of the

displacements measured at both crack widths shall be recorded after the anchor successfully completes the crack cycle. The mean displacement corresponding to  $\Delta w = 0.5 \text{ mm}$  shall be less than 7 mm. If this displacement limit is not met then the tests shall be repeated with further reduced value of  $N_{w1}$  &  $N_{w2}$  and  $\alpha_{ts,S6}$ , shall be recalculated with this reduced load value. Minimum of the  $\alpha_{TS,S6}$  value calculated as per **8.4.6(a)(1)** and **(2)** shall be used.

b) Assessment of residual load test of Test Series S6

1) Assessment of ultimate failure load of Test Series S6 – The reduction factor shall be determined as follows. Prior to comparison of results of both test series, the load values shall be normalized to 25 MPa concrete strength, depending on the failure type observed in the test series. Alternatively, the results of Test Series S1 may be normalized to that of S6.

$$\alpha_{ts,S6'} = \begin{cases} 1 & \text{if } N_{u,m,ts,S6} \geq 0.9N_{u,m,ts,S1} \\ N_{u,m,ts,S6}/0.9N_{u,m,ts,S6} & \text{if } N_{u,m,ts,S6} < 0.9N_{u,m,ts,S1} \end{cases}$$

NOTE – Instead of calculating, it may also be permitted to repeat crack cycle with further reduced value of  $N_{w1}$  &  $N_{w2}$  to fulfill the above requirement.

2) The scatter of ultimate failure load of Test Series S6 shall be assessed as per **8.2.2(a)(2)**. If the coefficient of variation is higher than 30% then the anchor shall be deemed unsuitable for use in seismic situation.

3) The load-displacement behavior of Test Series S6 shall be assessed as per **8.2.2(b)**. If this condition is not met then the anchors shall be deemed unsuitable for use in seismic conditions.

NOTE – This requirement is not applicable if this displacement (that is, at 50 percent of the mean ultimate failure load) is less than or equal to 0.4 mm.

4) The final reduction factor of Test Series S6 shall be calculated as follows.

$$\alpha_{ts,S6} = \alpha_{ts,S6'} * \alpha_{ts,S6''}$$

#### 8.4.7 Determination of Governing Reduction Factors

a) The governing reduction factors for tension for seismic shall be determined as follows

$$\alpha_N = \min(\alpha_{ts,S4}; \alpha_{ts,S6}) \cdot \alpha_{ts,S1,S2}$$

$$\beta_{vF,N} = \min(\beta_{ts,S4}; \beta_{ts,S6}) \cdot \beta_{ts,S1,S2}$$

The calculated reduction factor shall be applicable to the embedment depth that has been tested as well as to shorter embedment depths than the one tested.

NOTE – If multiple embedment depths have been tested for an anchor diameter and different failure type were observed in these tests then it shall be permitted to calculate different reduction factor for steel and pull-out failure.

b) The governing reduction factors for shear for seismic shall be determined as follows

$$\alpha_V = \alpha_{ts,S3} * \alpha_{ts,S5}$$

$$\beta_{vF,V} = \min(\beta_{ts,S3}; \beta_{ts,S5})$$

The calculated reduction factor shall be applicable to the embedment depth that has been tested as well as longer embedment depths than the one tested.

NOTE – If multiple embedment depths have been tested for an anchor diameter then the reduction factors for intermediate depths may be determined by linear interpolation.

#### 8.4.8 Determination of Characteristic Strength under Seismic Conditions

a) The characteristic steel strength in tension under seismic conditions,  $N_{Rk,s,seis}$ , shall be determined as follows.

$$N_{Rk,s,seis} = \alpha_N \beta_{vF,N} N_{Rk,s}$$

where

$N_{Rk,s}$  = Characteristic steel strength determined for static conditions as per **8.2.1**.

b) The characteristic pull-out strength in tension under seismic conditions,  $N_{Rk,p,seis}$ , shall be determined as follows.

$$N_{Rk,p,seis} = \alpha_N \beta_{vF,N} N_{Rk,0}$$

where

$N_{Rk,0}$  = Characteristic strength determined from Test series 8 and 9 after normalization of test loads to 25 MPa concrete strength.

NOTE

Characteristic strength may be determined from Test Series 8 and 9 by using any of the following methods:

- a) Minimum of characteristic strength value of Test Series 8 and 9
- b) Characteristic strength determined from combined test data of Test Series 8 and 9
- c) Maximum of (a) and (b)

The calculated  $N_{Rk,p,seis}$  shall be applicable to the embedment depth that has been tested as well as to shorter embedment depths than the one tested.

c) The characteristic steel strength in shear under seismic conditions,  $V_{Rk,s,seis}$ , shall be determined as follows. Only steel failure type is considered in seismic evaluation for shear.

$$V_{Rk,s,seis} = \alpha_V \beta_{vF,V} V_{Rk,s}^0$$

where

$V_{Rk,s}^0$  = Characteristic steel strength determined for static conditions as per **8.3.1**

The calculated  $V_{Rk,s,seis}$  shall be applicable to the embedment depth that has been tested as well as to longer embedment depths than the one tested. If multiple embedment depths have been tested for an anchor diameter then the characteristic resistance for intermediate depths may be determined by linear interpolation.

d) The anchor displacement at damage limit state and ultimate limit state for seismic conditions shall be determined as per Table 9.

**Table 9 Displacements to be Reported in AR**

[Clause 8.4.7(d)]

Displacement <sup>1</sup>	Determination process <sup>2</sup>
$\delta_{N,seis(DLS)}$	Maximum of mean value of displacements at $0.5 N/N_{max}$ as per (Test Series S4 and at $\Delta w = 0.5 \text{ mm}$ (as per Test Series S6)
$\delta_{N,seis(ULS)}$	Maximum of mean value of displacements at $1.0 N/N_{max}$ as per (Test Series S4 and at $\Delta w = 0.8 \text{ mm}$ (as per Test Series S6)
$\delta_{V,seis(DLS)}$	Mean value of displacement at $0.5 V/V_{max}$ (as per Test Series S5)
$\delta_{V,seis(ULS)}$	Mean value of displacement at $1.0 V/V_{max}$ (as per Test Series S5)

**NOTES**

<sup>1</sup> DLS is Damage limit state and ULS is Ultimate limit state.

<sup>2</sup> If  $N_{max}$  or  $V_{max}$  had to be reduced in the test series then the ratio  $N/(N_{max, \text{reduced}})$  or  $V/(V_{max, \text{reduced}})$  shall be used (as applicable).

e) The partial safety factor for seismic design shall be taken as same as static.



**ANNEX A***(Clause 2)***LIST OF REFERRED INDIAN STANDARDS**

<i>IS No.</i>	<i>Title</i>
CED 02 (25733)	Draft standard on Design of Post-installed Anchorage to Concrete - Code of Practice
CED 02 (25735)	Draft standard on Testing and Assessment of performance of post-installed mechanical Anchoring Systems
1608 (Part 1) : 2022	Mechanical testing of metals - Tensile testing ( <i>first revision</i> )
1893 (Part1) : 2016	Criteria for earthquake resistant design of structures ( <i>sixth revision</i> )
456 : 2000	Plain and reinforced concrete - Code of practice ( <i>fourth revision</i> )
875	Code of practice for design loads (Other Than Earthquake) for buildings and structures
(Part 1) : 1987	Dead loads - Unit weights of building materials and stored materials ( <i>second revision</i> )
(Part 2) : 1987	Imposed loads ( <i>second revision</i> )
(Part 3) : 2015	Wind Loads ( <i>third revision</i> )
(Part 4) : 2021	Snow Loads
(Part 5) : 1987	Special loads and load combinations ( <i>second revision</i> )
16700 : 2023	Criteria for structural safety of tall concrete buildings ( <i>first revision</i> )

## ANNEX B

### GENERAL ASSESSMENT METHOD

#### B-1 CONVERSION OF TEST RESULTS TO NOMINAL STRENGTH

During conversion of test results to nominal strength the type of failure shall be taken into account.

**B-1.1** When the anchor system fails in concrete, the test result shall be normalized to nominal concrete strength  $f_{cm}$  as follows:

$$F_{u,c} = F_{u,ts} \left( \frac{f_{cm}}{f_{cm,ts}} \right)^{0.5} \text{ with } f_{cm}/f_{cm,ts} \leq 1$$

where

$F_{u,ts}$  = Ultimate load measured in a test series

$F_{u,c}$  = Ultimate failure load at concrete compressive strength  $f_{cm}$

$f_{cm,ts}$  = Mean compressive cube strength of concrete test member at the time of testing anchor samples

**B-1.2** When the anchor fails in pullout (bond failure), the test result shall be normalized as follows:

$$F_{u,c} = F_{u,ts} \left( \frac{f_{cm}}{f_{cm,ts}} \right)^{n'} \text{ with } f_{cm}/f_{cm,ts} \leq 1$$

where

For uncracked concrete (confined test):  $n' = \log(N_{u,m,ts4}/N_{u,m,ts3})/\log(f_{cm,ts4}/f_{cm,ts3}) \leq 0.5$

For cracked concrete (confined test):  $n' = \log(N_{u,m,ts6}/N_{u,m,ts5})/\log(f_{cm,ts6}/f_{cm,ts5}) \leq 0.5$

For uncracked concrete (unconfined test):

$$n' = \log(N_{u,m,ts12}/N_{u,m,ts11})/\log(f_{cm,ts12}/f_{cm,ts11}) \leq 0.5$$

For cracked concrete (unconfined test):

$$n' = \log(N_{u,m,ts14}/N_{u,m,ts13})/\log(f_{cm,ts14}/f_{cm,ts13}) \leq 0.5$$

NOTE – If no distinction is made between cracked and uncracked conditions then the normalization factor,  $n'$ , shall be taken as minimum of all equations above for  $n'$ .

**B-1.3** When the anchor fails in steel, the test result shall be normalized to the nominal steel strength  $f_u$  as follows:

$$F_{u,s} = F_{u,ts} \left( \frac{f_u}{f_{u,ts}} \right)$$

where

$F_{u,s}$  = Ultimate failure load at nominal steel ultimate strength  $f_u$

- $f_{u,ts}$  = Steel ultimate tensile strength corresponding to anchor used for the test  
 $F_{u,ts}$  = Ultimate load measured in a test series

## B-2 DETERMINATION OF 5<sup>th</sup> PERCENTILE VALUE

The 5<sup>th</sup> percentile of the ultimate load shall be calculated from the ultimate loads measured in a test series according to statistical procedures for a confidence level of 90%. A normal distribution and an unknown standard deviation of the population shall be assumed. The 5<sup>th</sup> percentile shall be determined as follows:

$$F_{5\%} = F_{u,m,ts}(1 - k_s v_F)$$

where

- $F_{5\%}$  = 5<sup>th</sup> percentile value of the load in a test series  
 $F_{u,m,ts}$  = Mean ultimate load in a test series  
 $k_s$  = Owens no. [ $k_s = 3.4$  and  $2.57$  for test series with 5 and 10 samples, respectively]  
 $v_F$  = Coefficient of variation [%] related to loads

## B-3 DETERMINATION OF 95<sup>th</sup> PERCENTILE VALUE

The 95<sup>th</sup> percentile value shall be calculated from the ultimate loads measured in a test series according to statistical procedures for a confidence level of 90%. A normal distribution and an unknown standard deviation of the population shall be assumed. The 95<sup>th</sup> percentile shall be determined as follows:

$$F_{95\%} = F_{u,m,ts}(1 + k_s v_F)$$

$$\tau_{Rk,95\%} = \tau_{u,m,ts}(1 + k_s v_F)$$

where

- $F_{95\%}$  = 95<sup>th</sup> percentile of the ultimate load in a test series  
 $F_{u,m,ts}$  = Mean ultimate load of a test series  
 $\tau_{95\%}$  = 95<sup>th</sup> percentile of bond strength determined in a test series  
 $\tau_{u,m,ts}$  = Mean ultimate load bond strength of a test series  
 $k_s$  = Owens no. [ $k_s = 3.4$  and  $2.57$  for test series with 5 and 10 samples, respectively]  
 $v_F$  = Coefficient of variation (in %) related to loads

## B-4 CONVERSION OF TEST RESULTS TO BOND STRENGTH

The failure load of a test series with bond failure shall be converted to bond strength corresponding to the nominal diameter of fastening element tested as follows.

$$\tau_{u,m} = N_{u,m}/(\pi d_a h_{ef})$$

$$\tau_{Rk} = N_{Rk}/(\pi d_a h_{ef})$$

## B-5 CONVERSION OF TEST RESULTS TO ACCOUNT FOR CONCRETE BATCH INFLUENCE

The failure load of a test series with bond failure, carried out in “i” concrete batch, shall be converted as follows. This conversion is applicable only for bond failure. The factor  $\alpha_{ref,i}$  shall be taken as 1 if the coefficient of variation of ultimate loads in reference test series with medium diameter is less than or equal to 15%. In this case the 5<sup>th</sup> percentile of the bond resistance in the reference test series (TS 3 to TS 6 and TS 11 to TS 14) shall be determined with a coefficient of variation of 15%.

$$N_{u,p} = N_{u,ts,i} \alpha_{ref,i}$$

Where,

$\alpha_{ref,i}$  = Factor to account for sensitivity of adhesive anchor to specific concrete batch using results of reference test

$$\alpha_{ref,i} = \frac{\min(\tau_{u,m,r,12mm})}{\tau_{u,m,i,12mm}} \leq 1$$

$\min(\tau_{u,m,r,12mm})$  = Minimum value of mean bond strength determined from reference tests with medium size (i.e. 12 mm) anchor.

NOTE – The mean bond strength shall be calculated for each applicable reference test and the minimum value shall be taken.

$\tau_{u,m,i,12mm}$  = Mean bond strength determined from tests carried out in “i” concrete batch with medium size (i.e. 12 mm) anchor.

## B-6 DETERMINATION OF REDUCTION FACTOR $\beta_{vF}$

**B-6.1** If the coefficient of variation of the ultimate load in any reference test series, basic tension tests with unconfined test set up and test to determine shear strength exceeds 15% but is less than 30% then the mean ultimate load of that series shall be multiplied with the following reduction factor,  $\beta_{vF}$ , to accommodate for inconsistent behavior.

$$\beta_{vF} = 1/[1 + 0.03(v_F - 15)] \leq 1$$

**B-6.2** If the coefficient of variation of the ultimate load in any test series other than the reference test series (except slice test and minimum edge & spacing test) exceeds 20% but is less than 30% then the mean ultimate load of that series shall be multiplied with the following reduction factor,  $\beta_{vF}$ , to accommodate for inconsistent behavior.

$$\beta_{vF} = 1/[1 + 0.03(v_F - 20)] \leq 1$$

**B-6.3** If the coefficient of variation of the ultimate load exceeds 30% then the number of test shall be increased until the criteria for coefficient of variation is met.

**B-6.4** This modification factor does not apply to test series where the coefficient of variation is less than defined limit of 15% and 20% depending on the test series as defined in **B-6.1** and **B-6.2**.

**B-6.5** The smallest value of  $\beta_{vF}$  in any test shall be taken for assessment.

## B-7 DETERMINATION OF REDUCTION FACTOR $\alpha_p$

If the sustained load applied on the anchor in sustained load tests, repeated load test and crack cycling test (of static condition assessment) is reduced to fulfill the requirement of the test the reduction factor,  $\alpha_p$ , shall be calculated as follows.

$$\alpha_p = \frac{\text{Reduced } N_{sus,ts}}{\text{Required } N_{sus,ts}} \leq 1$$

Where,

*Reduced*  $N_{sus,ts}$  = The reduced sustained load applied on the anchor to fulfill requirement of test

*Required*  $N_{sus,ts}$  = Required sustained load calculated for the test series.

The smallest value of  $\alpha_p$  in any test shall be taken for assessment.

## B-8 DETERMINATION OF REDUCTION FACTOR $\alpha$

**B-8.1** For some of the tests series as mentioned in this standard, the  $\alpha$  reduction factor shall be calculated by comparing the ultimate load and characteristic load of the respective tension test series to corresponding reference tension test series as follows.

$$\alpha = \min \left[ \left( \frac{F_{u,m,ts}}{F_{u,m,r}} \right), \left( \frac{F_{5\%,ts}}{F_{5\%,r}} \right) \right] < 1$$

**B-8.2** It shall not be required to determine ratio of characteristic loads equation given in **B-8.1** if the coefficient of variation of the test series is smaller than or equal to the coefficient of variation of the reference test series or if the coefficient of variation in both test series is less than 15%.

NOTE – With the exception of various installation condition tests, the characteristic value expected to be derived from this standard (that is, the value expected to be published in AR) may be used as reference for comparison.

## B-9 CRITERIA ACCEPTABLE LOAD DISPLACEMENT BEHAVIOR AND ANALYSIS OF DISPLACEMENTS

**B-9.1** The load-displacement curves shall show a steady increase in load. For adhesive anchors, uncontrolled slip may occur when the adhesive with the embedded part of adhesive anchor is pulled out of the drilled hole and the change in stiffness of load-displacement curve indicates occurrence of this slip.

**B-9.2** The load at loss of adhesion  $N_{u,adh}$ , that is the load at onset of uncontrolled slip, shall be determined for every test from the load-displacement curve. It is characterized as the load at which stiffness changes [see Fig. 20(a)]. If a definite point on the load-displacement curve does not indicate change in stiffness, e.g., see Fig. 20(b), then the load at loss of adhesion shall be determined using the following steps:

Step 1 – The tangent to the load-displacement curve shall be computed at  $0.3N_{u,test}$ . The tangent stiffness shall be taken as the secant stiffness between the points (0,0) and  $(0.3N_{u,test}, \delta_{0.3})$ , where  $\delta_{0.3}$  is displacement at load of  $0.3N_{u,test}$ .

Step 2 – The tangent stiffness determined in step 1 shall be divided with a factor of 1.5.

Step 3 – A line shall be drawn through the point (0,0) with the factored stiffness as calculated in step 2 above.

Step 4 – The point of intersection between line drawn in step 3 and the load-displacement curve shall be taken as the load  $N_{u,adh}$  [see Fig. 20(b)]. If the peak of the load-displacement curve lies to the left of this line and is higher than the load at intersection, then the peak load shall be taken as  $N_{u,adh}$  (see Fig. 20(c)). If the load-displacement curve is very stiff at the beginning ( $\delta_{0.3} \leq 0.05$  mm) then steps 1 to 4 should be carried out at  $0.6N_{u,test}$  using corresponding displacement  $\delta_{0.6}$  [see Fig. 20(d)].

Factor  $\alpha_1$  shall be determined according to the following equation. The minimum value of factor  $\alpha_1$  obtained shall be decisive.

$$\alpha_1 = \frac{N_{u,adh}}{N_{Rk,p}} \frac{1.5\gamma_{inst}}{1.3} \leq 1$$

where

$N_{u,adh}$  = Load at loss of adhesion

$N_{Rk,p}$  = Characteristic pull-out strength in concrete strength class and state of concrete (cracked or uncracked)

$\gamma_{inst}$  = Partial safety factor for installation

If failure occurs between adhesive and embedded part along the entire embedment depth, then evaluation of the load at loss of adhesion shall not be required and the factor  $\alpha_1$  shall be taken as 1.0.

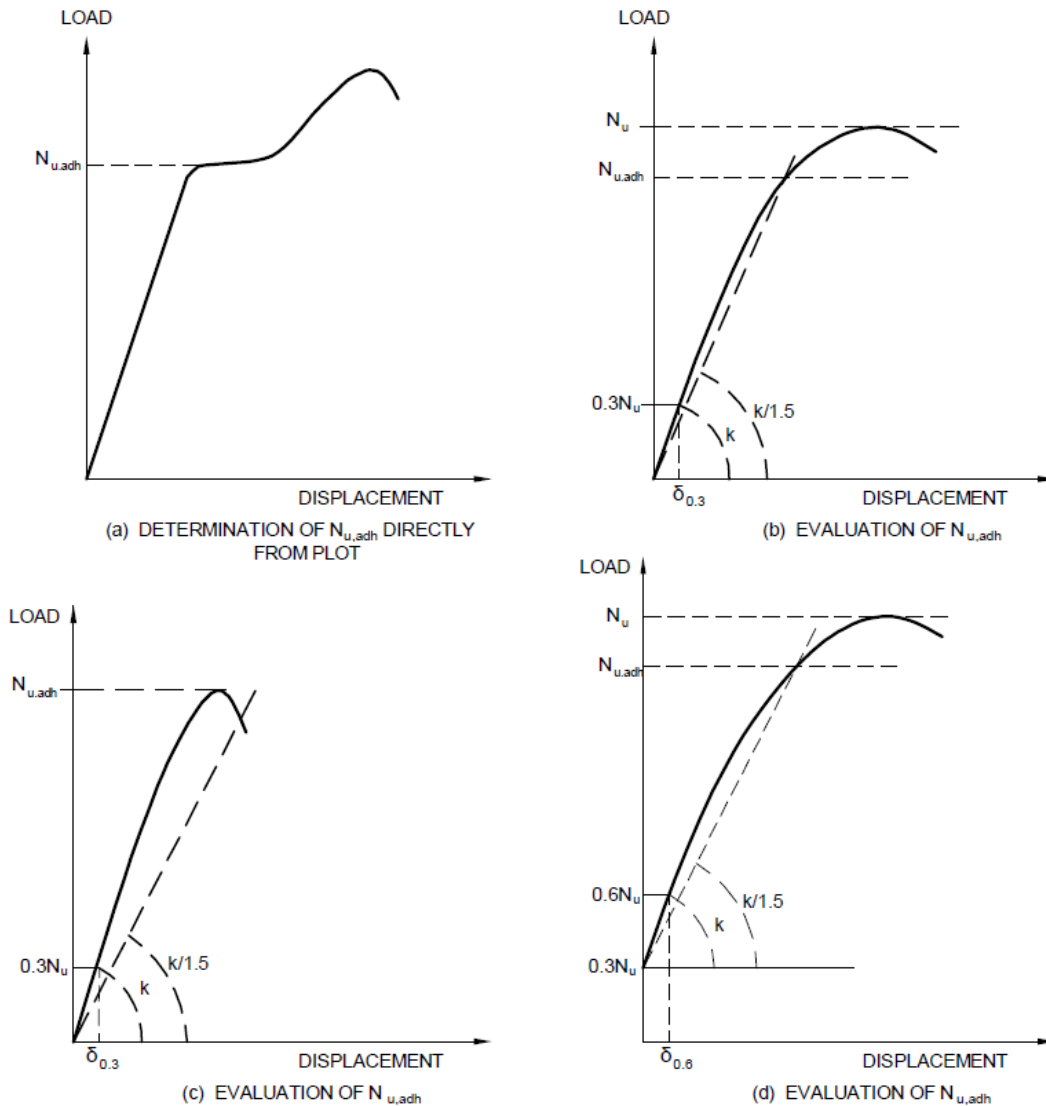

FIG. 20 PROCESS OF DETERMINATION OF  $N_{u,adh}$

**B-10 CRITERIA FOR COEFFICIENT OF VARIATION OF DISPLACEMENT**

**B-10.1** For reference tests, the coefficient of variation of the anchor displacement at a load corresponding to  $0.5F_{u,m,ts}$  of that test series shall be lower than 25% (i.e.  $v_\delta \leq 0.25$ ). For other tests, this value shall be lower than 40% (i.e.  $v_\delta \leq 0.40$ ), unless otherwise mentioned in Table 2.

It shall be permitted to increase no. of tests in a test series to fulfill this requirement.

**B-10.2** The load-displacement curves shall be shifted according to Fig. 21 for determination of displacement at  $0.5F_{u,m,ts}$ .

**B-10.3** It shall not be necessary to observe this limitation on the scatter of the load-displacement curves if in the test series all displacements at a load corresponding to  $0.5F_{u,m,ts}$  are smaller than or equal to 0.4 mm.

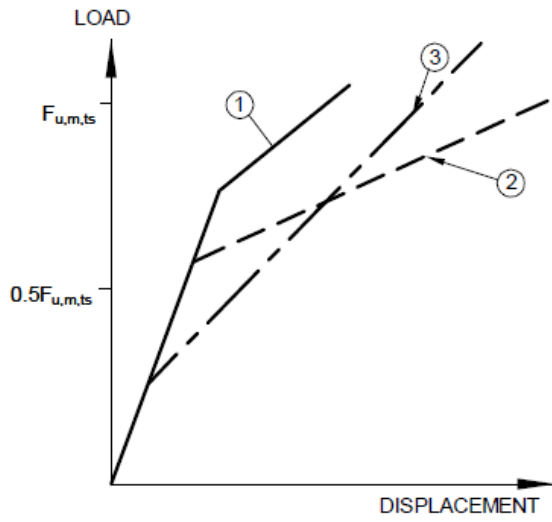

21 A ORIGINAL CURVES

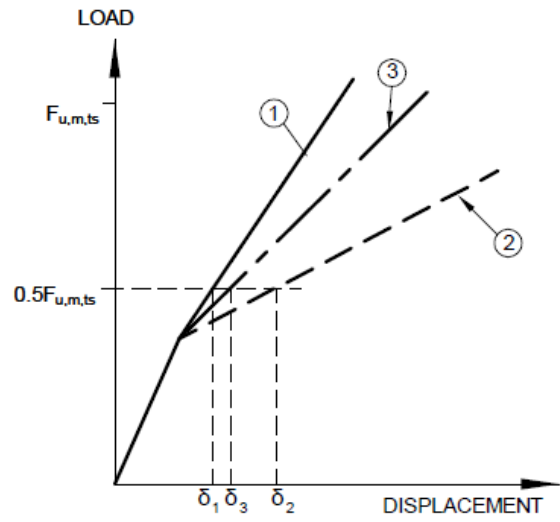

21 B EXAMPLES OF SHIFTING OF CURVES FOR EVALUATION OF SCATTER AT LOAD OF  $0.5 F_{u,m,ts}$

FIG. 21 INFLUENCE OF PRESTRESSING ON LOAD-DISPLACEMENT CURVES



**ANNEX C**

(Clauses 3.1.4, 3.2, 3.4.1)

**SAMPLE FORMAT FOR ASSESSMENT REPORT****C-1 Sample format for Assessment Report (AR)**

1. Description of product
NOTE -This section should give an overview of the technical aspects of the product, product types, grades etc.
2. Assumption for assessment
NOTE - This section should give overview of assumption or basis of use and intended design or service life
3. Performance category and assessment method used
NOTE -This section should give information on the assessment type (Option 1, 2 or 3) and any other performance criteria.
4. General product drawing, nomenclature and identification markings
NOTE - This section should contain general anchor drawing (without dimensions), the nomenclature used for different parts etc.
5. Material information
NOTE - This section should contain generic information on material that is used to make different parts of anchor along with standard (if applicable). For example bolt – 316 Stainless steel
6. Installation components, condition and instruction
NOTE - This section should contain information on different tools necessary for installation, the condition for installation (e.g., dry environment, temperature etc.), information on how to install in various conditions, tables for installation parameters etc.
7. Specification of intended use
NOTE – This section should contain information on environment conditions covered, base material information, assumption for applicability of AR for design, supported design method etc.
8. Characteristic load table for static conditions for each product type as per assessment (see <b>B-2</b> and <b>B-3</b> )
9. Characteristic load table for seismic conditions for each product type as per assessment (see <b>B-4</b> and <b>B-5</b> )
10. Information on anchor displacement as per assessment (see <b>B-6</b> and <b>B-7</b> )

**C-2 Sample Format for Tension Load for Static Conditions**

<b>Anchor diameter</b>	$d_a$ (mm)	8	10	12	16 etc.
------------------------	------------	---	----	----	------------

<b>Effective embedment depth</b>	$h_{ef}$ (mm)				
<b>Steel failure</b>					
Characteristic steel strength	$N_{Rk,s}$ (kN)				
Partial Safety factor	$\gamma_{Ms}$				
<b>Pull-out failure</b>					
Characteristic pull-out strength in uncracked concrete for 50 years service life					
Temperature range (a):	$\tau_{Rk,uncr',50}$ (N/mm <sup>2</sup> )				
Temperature range (b):	$\tau_{Rk,uncr',50}$ (N/mm <sup>2</sup> )				
Temperature range (c):	$\tau_{Rk,uncr',50}$ (N/mm <sup>2</sup> )				
Characteristic bond resistance in cracked concrete					
Temperature range (a):	$\tau_{Rk,cr',50}$ (N/mm <sup>2</sup> )				
Temperature range (b):	$\tau_{Rk,cr',50}$ (N/mm <sup>2</sup> )				
Temperature range (c):	$\tau_{Rk,cr',50}$ (N/mm <sup>2</sup> )				
Partial Safety factor	$\gamma_{Mp}$				
Influencing factor for sustained loading					
Temperature range (a):	$\Psi_{sus,50}^0$				
Temperature range (b):	$\Psi_{sus,50}^0$				
Temperature range (c):	$\Psi_{sus,50}^0$				
Bond strength increasing factor for different concrete grades ( $\Psi_c$ )	$\Psi_c$				
Characteristic pull-out strength in uncracked concrete for 100 years service life					
Temperature range (a):	$\tau_{Rk,uncr',100}$ (N/mm <sup>2</sup> )				
Temperature range (b):	$\tau_{Rk,uncr',100}$ (N/mm <sup>2</sup> )				
Temperature range (c):	$\tau_{Rk,uncr',100}$ (N/mm <sup>2</sup> )				
Characteristic bond resistance in cracked concrete					
Temperature range (a):	$\tau_{Rk,cr',100}$ (N/mm <sup>2</sup> )				
Temperature range (b):	$\tau_{Rk,cr',100}$ (N/mm <sup>2</sup> )				
Temperature range (c):	$\tau_{Rk,cr',100}$ (N/mm <sup>2</sup> )				
Partial Safety factor	$\gamma_{Mp}$				

Influencing factor for sustained loading					
Temperature range (a):	$\Psi_{sus,100}^0$				
Temperature range (b):	$\Psi_{sus,100}^0$				
Temperature range (c):	$\Psi_{sus,100}^0$				
Bond strength increasing factor for different concrete grades ( $\Psi_c$ )	$\Psi_c$				
<b>Concrete cone and splitting factor</b>					
Critical spacing	$s'_{cr,N}$				
	$s'_{cr,sp}$				
Critical edge distance	$c'_{cr,N}$				
	$c'_{cr,sp}$				
Partial safety factor	$\gamma_{inst}$				
	$\gamma_{Mc}$				

### C-3 Sample Format for Shear Load for Static Conditions

Anchor diameter	$d_a$ (mm)	8	10	12	16
Effective embedment depth	$h_{ef}$ (mm)				
<b>Steel failure without lever arm</b>					
Characteristic steel strength	$V_{Rk,s}$ (kN)				
Partial Safety factor	$\gamma_{Ms}$				
Ductility factor <sup>1</sup>	$k_1$				
<b>Steel failure with lever arm</b>					
Characteristic steel strength	$M_{Rk,s}^0$ (kN)				
Partial Safety factor	$\gamma_{Ms}$				
<b>Concrete pryout</b>					
Pryout factor	$k_{cp}$				
Partial safety factor	$\gamma_{Mc}$				
<b>Concrete edge failure</b>					
Lever arm or effective length of anchor in shear loading	$l$				
Partial safety factor	$\gamma_{Mc}$				

<b>Critical edge and spacing</b>					
Critical spacing	$s'_{cr,v}$ (mm)				
Critical edge distance	$c'_{cr,v}$ (mm)				

**C-4 Sample Format for Tension Load for Seismic Conditions**

<b>Anchor diameter</b>	$d_a$ (mm)	8	10	12	16
<b>Effective embedment depth</b>	$h_{ef}$ (mm)				
<b>Steel failure</b>					
Characteristic steel strength	$N_{Rk,s,seis}$ (kN)				
Partial Safety factor	$\gamma_{Ms}$				
<b>Pullout/Bond failure</b>					
Characteristic bond resistance in cracked concrete					
Temperature range (a):	$\tau_{Rk,seis}$ (N/mm <sup>2</sup> )				
Temperature range (b):	$\tau_{Rk,seis}$ (N/mm <sup>2</sup> )				
Temperature range (c):	$\tau_{Rk,seis}$ (N/mm <sup>2</sup> )				

**C-5 Sample Format for Shear Load for Seismic Conditions**

<b>Anchor diameter</b>	$d_a$ (mm)	8	10	12	16
<b>Effective embedment depth</b>	$h_{ef}$ (mm)				
<b>Steel failure</b>					
Characteristic steel strength	$V_{Rk,s,seis}$ (kN)				
Partial Safety factor	$\gamma_{Ms}$				
<b>Concrete pryout and concrete edge failure</b>					
Partial Safety factor	$\gamma_{Mc}$				

**C-6 Sample Format for Displacements for Static Conditions**

<b>Anchor diameter</b>	$d_a$ (mm)	8	10	12	16
<b>Effective embedment depth</b>	$h_{ef}$ (mm)				
<b>Displacement under tension for Temperature range (a)</b>					
Displacement in tension in uncracked concrete	$\delta_{N0}$ (N/mm <sup>2</sup> )				
	$\delta_{N\infty}$ (N/mm <sup>2</sup> )				

Displacement in tension in cracked concrete	$\delta_{N0}$ (N/mm <sup>2</sup> )				
	$\delta_{N\infty}$ (N/mm <sup>2</sup> )				
Displacement in shear	$\delta_{V0}$ (N/mm <sup>2</sup> )				
	$\delta_{V\infty}$ (N/mm <sup>2</sup> )				

### C-7 Sample Format for Displacements for Seismic Conditions

<b>Anchor diameter</b>	$d_a$ (mm)	8	10	12	16
<b>Effective embedment depth</b>	$h_{ef}$ (mm)				
Displacement @ DLS in Tension	$\delta_{N,seis(DLS)}$ (mm)				
Displacement @ ULS in Tension	$\delta_{N,seis(ULS)}$ (mm)				
Displacement @ DLS in Shear	$\delta_{V,seis(DLS)}$ (mm)				
Displacement @ ULS in Shear	$\delta_{V,seis(ULS)}$ (mm)				

**ANNEX D**

**PROCEDURE FOR ISSUING ASSESSMENT REPORT**

A suggestive format for the body engaged in assessing and reporting of anchors is given in Fig. 30.

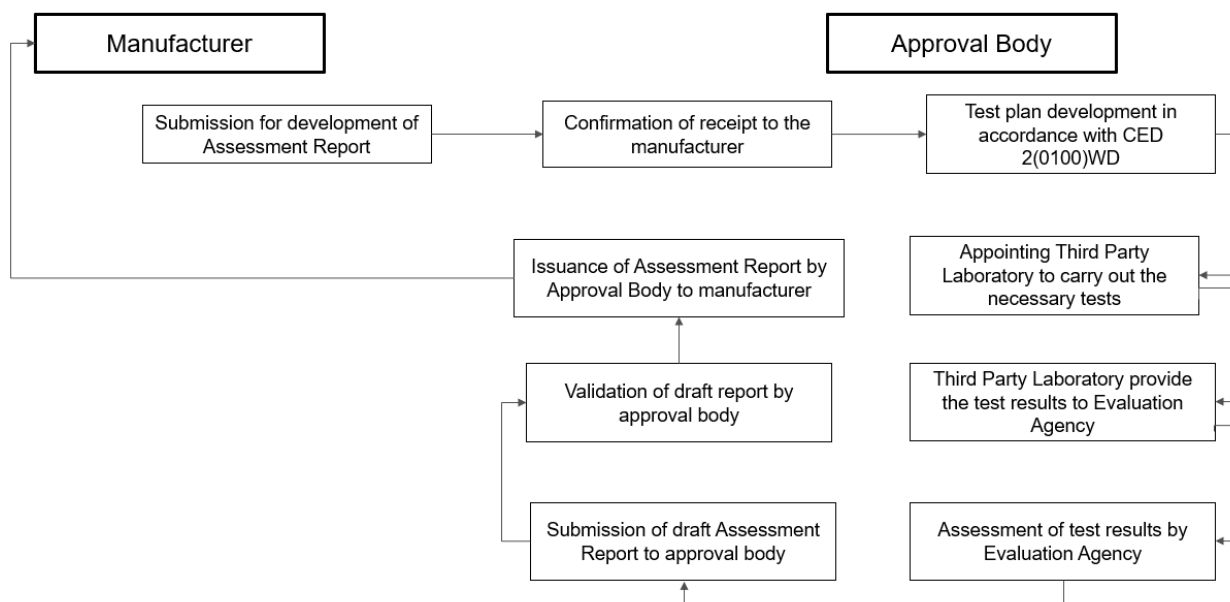

FIG. 30 PROCEDURE OF ASSESSMENT AND REPORTING OF ANCHORS

The following lists the role of respective parties involved in the assessment:

- a) *Approval Body* – It may be an institute of national acceptance/recognition having experience in the field of testing and assessment of post installed anchors.
- b) *Third Party Laboratory* – It may be an independent accredited laboratory or in-house test laboratories of the approval body having experience in the field of testing post installed anchors.
- c) *Evaluation Agency* – It may preferably be an independent institute of national recognition with proven experience in the field of assessment of post installed anchors. They may be the same as Approval Body or separately established.

Limited and isolated research work is available/carried out on date in the country and there is a need for comprehensive testing and assessment of post installed anchors considering the increasing use of such anchors in the country. Adequate training to such bodies and competence development is thus essential so as to have the competent bodies within the country to issue the test reports.

Users of anchors are encouraged to verify the testing/assessment reports issued by reputed bodies who could demonstrate independently the above mentioned criteria.

**Annex E**

(Committee composition will be added after finalization)

\*\*\*\*\*