



भारतीय मानक ब्यूरो

(उपभोक्ता मामले, खाद्य एवं सार्वजनिक वितरण मंत्रालय, भारत सरकार)

BUREAU OF INDIAN STANDARDS

मानक भवन, 9, बहादुर शाह ज़फर मार्ग, नई दिल्ली - 110002

Manak Bhawan, 9, Bahadur Shah Zafar Marg, New Delhi - 110002

Phones: 23230131 / 2323375 / 23239402

Website: www.bis.gov.in, www.manakonline.in

व्यापक परिचालन मसौदा

हमारा संदर्भ : सीईडी 02:2/टी-105

30 मई 2024

तकनीकी समिति : सीमेंट और कंक्रीट अनुभागीय समिति , सीईडी 02

प्राप्तकर्ता :

- सिविल अभियांत्रिकी विभाग परिषद, सीईडीसी के सभी सदस्य
- सीमेंट और कंक्रीट अनुभागीय समिति , सीईडी 02
- सीईडी 02 की उपसमितियों और अन्य कार्यदल के सभी सदस्य
- रुचि रखने वाले अन्य निकाय।

महोदय/महोदया,

निम्नलिखित मानक का मसौदा संलग्न है:

प्रलेख संख्या	शीर्षक
सीईडी 02(25733)WC	कंक्रीट पर पोस्ट स्थापित एंकरेज का डिज़ाइन - रीति संहिता (आई सी एस संख्या : 91.100.30)

कृपया इस मसौदे का अवलोकन करें और अपनी सममतियाँ यह बताते हुए भेजे कि यह मसौदा प्रकाशित हो तो इन पर अमल करने में आपको व्यवसाय अथवा कारोबार में क्या कठिनाइयाँ आ सकती हैं।

सममतियाँ भेजने की अंतिम तिथि: 30 जुलाई 2024

सममति यदि कोई हो तो कृपया अधोहस्ताक्षरी को ई-मेल द्वारा ced2@bis.gov.in पर या उपरलिखित पते पर, संलग्न फॉर्मेट में भेजें। सममतियाँ बीआईएस ई-गवर्नेंस पोर्टल, www.manakonline.in के माध्यम से ऑनलाइन भी भेजी जा सकती हैं।

यदि कोई सममति प्राप्त नहीं होती है अथवा सममति में केवल भाषा संबंधी त्रुटि हुई तो उपरोक्त प्रालेख को यथावत अंतिम रूप दे दिया जाएगा। यदि सममति तकनीकी प्रकृति की हुई तो विषय समिति के अध्यक्ष के परामर्श से अथवा उनकी इच्छा पर आगे की कार्यवाही के लिए विषय समिति को भेजे जाने के बाद प्रालेख को अंतिम रूप दे दिया जाएगा।

यह प्रालेख भारतीय मानक ब्यूरो की वेबसाइट www.bis.gov.in पर भी उपलब्ध हैं।

धन्यवाद।

भवदीय

ह/-

द्वैपायन भद्र

वैज्ञानिक ई एवं प्रमुख

सिविल अभियांत्रिकी विभाग

संलग्न: उपरलिखित



भारतीय मानक ब्यूरो

(उपभोक्ता मामले, खाद्य एवं सार्वजनिक वितरण मंत्रालय, भारत सरकार)

BUREAU OF INDIAN STANDARDS

(Ministry of Consumer Affairs, Food & Public Distribution, Govt. of India)

मानक भवन, 9, बहादुर शाह ज़फर मार्ग, नई दिल्ली - 110002

Manak Bhawan, 9, Bahadur Shah Zafar Marg, New Delhi - 110002

Phones: 23230131 / 2323375 / 23239402

Website: www.bis.gov.in, www.manakonline.in

WIDE CIRCULATION DRAFT

Our Reference: CED 02:2/T-105

30 May 2024

TECHNICAL COMMITTEE: CEMENT AND CONCRETE SECTIONAL COMMITTEE, CED 02

ADDRESSED TO:

1. All Members of Civil Engineering Division Council, CEDC
2. All Members of Cement and Concrete Sectional Committee, CED 02 and its Subcommittees
3. All Members of Subcommittees, Panels and Working Groups under CED 02
4. All others interested.

Dear Sir/Madam,

Please find enclosed the following draft:

Doc No.	Title
CED 02(25733)WC	Design of Post - Installed Anchorage to Concrete - Code of Practice ICS 91.100.30

Kindly examine the attached draft and forward your views stating any difficulties which you are likely to experience in your business or profession, if this is finally adopted as National Standard.

Last Date for comments: 30 July 2024

Comments if any, may please be made in the enclosed format and emailed at ced2@bis.gov.in or sent at the above address. Additionally, comments may be sent online through the BIS e-governance portal, www.manakonline.in.

In case no comments are received or comments received are of editorial nature, kindly permit us to presume your approval for the above document as finalized. However, in case comments, technical in nature are received, then it may be finalized either in consultation with the Chairman, Sectional Committee or referred to the Sectional Committee for further necessary action if so desired by the Chairman, Sectional Committee.

The document is also hosted on BIS website www.bis.gov.in.

Thanking you,

Yours faithfully,

Sd/-

Dwaipayan Bhadra

Scientist 'E' & Head

Civil Engineering Department

Encl: As above

FORMAT FOR SENDING COMMENTS ON THE DOCUMENT

[Please use A4 size sheet of paper only and type within fields indicated. Comments on each clause/sub-clause/ table/figure, etc, be stated on a fresh row. Information/comments should include reasons for comments, technical references and suggestions for modified wordings of the clause. Comments through e-mail to ced2@bis.gov.in shall be appreciated.]

Doc. No.: CED 02(25733)WC

BIS Letter Ref: CED 02:2/T-105

Title: Design Of Post-Installed Anchorage To Concrete – Code of Practice

Last date of comments: 30 July 2024

Name of the Commentator/ Organization: _____

SI No.	Clause/ Para/ Table/ Figure No. commented	Type of Comment (General/ Technical/ Editorial)	Comments/ Modified Wordings	Justification of Proposed Change

NOTE- Kindly insert more rows as necessary for each clause/table, etc

BUREAU OF INDIAN STANDARDS**DRAFT STANDARD FOR COMMENTS ONLY**

(Not to be reproduced without the permission of BIS or used as an Indian Standard)

Draft Indian Standard

DESIGN OF POST-INSTALLED ANCHORAGE TO CONCRETE – CODE OF PRACTICE

ICS 91.100.30

**Cement and Concrete
Sectional Committee, CED 02****Last Date for Comments:
30 July 2024**

FOREWORD

(Formal clauses of the standard to be added later)

Various fastening techniques are used extensively for the transfer of loads into concrete structural elements. One such technique that is, post-installed anchors, installed in hardened structural concrete elements, has become quite common in the last two decades in India. Despite the extensive use of post-installed anchors in construction, the level of adequate knowledge regarding their behaviour is only increasing now.

Failure of connections poses risk to human life and considerable economic consequences. Hence, they should be designed, assessed and evaluated in accordance with the well-established engineering principles. Suitable guidance is therefore required for proper design of such system to ensure safety.

This standard has, therefore, been formulated to fulfill the above requirements. It addresses a variety of loading types and failure modes and takes into account the current state-of-the-art practices for post-installed anchorages in new concrete construction as well as for their use in the repair and strengthening of existing concrete structures. This standard would provide, thus, the requisite guidance regarding design and use of anchorages to concrete and would be of help to the designers, contractors and users alike.

In this standard, assumption has been made that the design of anchorages is entrusted to a qualified engineer and that the installation of anchorages to concrete is carried out under the direction of a qualified and experienced supervisor.

In the formulation of this standard, assistance has been derived from the following publications:

1. EN 1992-4 : 2018, Eurocode 2 - Design of concrete structures - Part 4: Design of fastenings for use in concrete
2. AS 5216 : 2018 Design of post-installed and cast-in fastenings in concrete, Standards Association of Australia
3. CEB-FIP Model Code 2011, Design of anchorages in concrete

An informative annex (see Annex C) on general requirements of installation and inspection of anchors to be adopted on the site has been included.

For the purpose of deciding whether a particular requirement of this standard is complied with, the final value, observed or calculated, expressing the result of a test or analysis shall be rounded off in accordance with IS 2: 2022 'Rules for rounding off numerical values (*revised*)'. The number of significant places retained in the rounded off value should be the same as that of the specified value in this standard.

BUREAU OF INDIAN STANDARDS

DRAFT STANDARD FOR COMMENTS ONLY

(Not to be reproduced without the permission of BIS or used as an Indian Standard)

Draft Indian Standard

DESIGN OF POST-INSTALLED ANCHORAGE TO CONCRETE - CODE OF PRACTICE

ICS 91.100.30

1 SCOPE

1.1 This standard deals with the design of post-installed mechanical anchors and post installed adhesive anchors in concrete when subjected to static, quasi-static or earthquake loads. The design method given in this standard is applicable only to anchors which have been tested and assessed according to CED 02(25734) and CED 02(25735). The Assessment Report (AR) of the anchor generated based on this assessment shall be referred to for various design parameters. The concrete that forms the base material for the connection shall be in conformity with IS 456 and IS 1343.

1.2 The provisions of this standard do not apply to cast-in anchors and to anchors in plastic hinge area.

1.3 Specialist literature may be referred for guidance in relation to fire, fatigue, or blast loads, where applicable.

2 REFERENCES

The standards (and documents) given in Annex A contain provisions which, through reference in this text, constitute provisions of this standard. At the time of publication, the editions indicated were valid. All standards are subject to revision, and parties to agreements based on these standards are encouraged to investigate the possibility of applying the most recent editions of the standards given in Annex A.

3 TERMINOLOGY

For the purpose of this standard, the definition of terms given below shall apply unless otherwise stated.

3.1 Adhesive — A bonding material which is used in adhesive anchor systems.

3.2 Anchor – Steel element, either cast into concrete or post installed into suitable base material, used to transmit the applied loads.

3.3 Anchorage or Anchoring System – An assembly of anchor or anchor group, fixture, and base material (example concrete) surrounding each anchor in which it is installed.

3.4 Anchor Displacement – Movement of the loaded end of the anchor relative to the concrete member into which it is installed, in the direction of the applied load.

3.5 Anchor Group – A number of anchors with identical dimension and characteristics acting together to support a common attachment.

3.6 Annular gap – Gap between the fastening element and concrete when embedded.

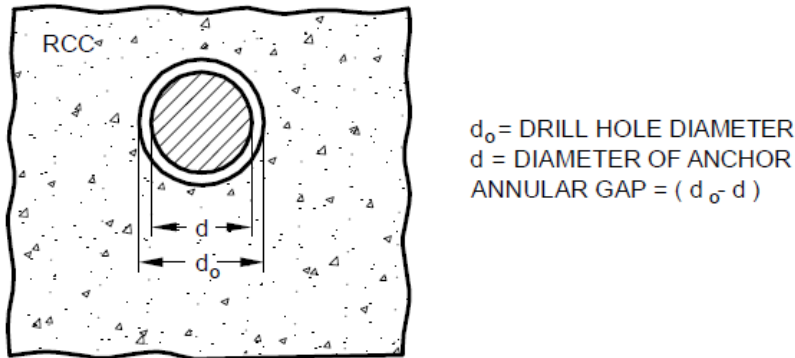

FIG. 1 ANNULAR GAP

3.7 Assessment report (AR) – Assessment report of a product (in this case post installed anchor) is the summary of prequalification of the anchor based on Technical Assessment Document (TAD) or a transparent and reproducible assessment that complies with the requirement relevant to the TAD.

3.8 Base material — The material in which post-installed anchor is installed.

NOTE: For the given standard, the scope is limited to cast in situ concrete or precast concrete.

3.9 Base plate – Metal assembly that transmits loads to the anchor.

3.10 Characteristic Value — The value below which not more than 5 percent of the test results are expected to fall.

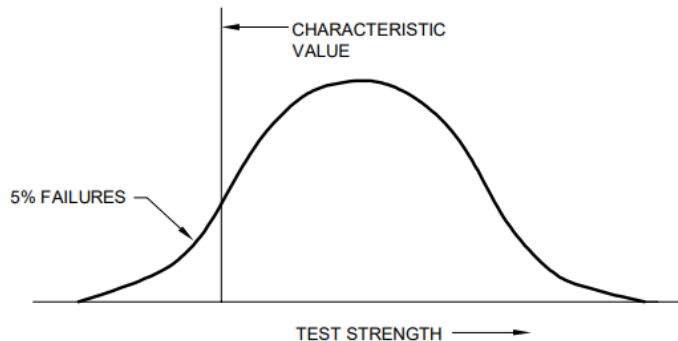

FIG. 2 TYPICAL CHARACTERISTIC VALUE

3.11 Concrete

3.11.1 Cracked Concrete – Concrete where there is probability of formation of cracks after installation of anchor or significant expansion of existing cracks during the service life of the anchors.

3.11.2 Uncracked Concrete – Concrete where there is no probability of the formation of cracks after installation, or the expansion of any existing crack (like shrinkage crack) is within the permissible limits during the service life of the anchors.

3.12 Durability – Ability of the anchorage system to contribute during the design service life of the structure under the corresponding service conditions at a performance level compatible with the structural requirements.

3.13 Edge distance – Distance perpendicular to the axis of the anchor from the center of anchor to the respective edge of the concrete member.

3.13.1 Critical Edge Distance – The edge distance of an anchor from the face of concrete at which there is no influence of edge on its characteristic strength.

3.13.2 Minimum Edge Distance – The minimum edge distance at which the anchor can be installed without damaging the concrete member.

NOTES

- 1 The critical edge distance is reflected in as the actual projected concrete cone area of the anchorage at the concrete surface. The critical dimension is representative of the idealized condition where presence of concrete edges or adjacent anchors does not influence the resistance of an anchor in a group.
- 2 Minimum edge distance is the minimum dimension needed to ensure the concrete is not damaged during installation. This minimum edge distance is less than the critical dimension. In such cases, the influence of limited concrete edge reduces the resistance of an anchor in a group.

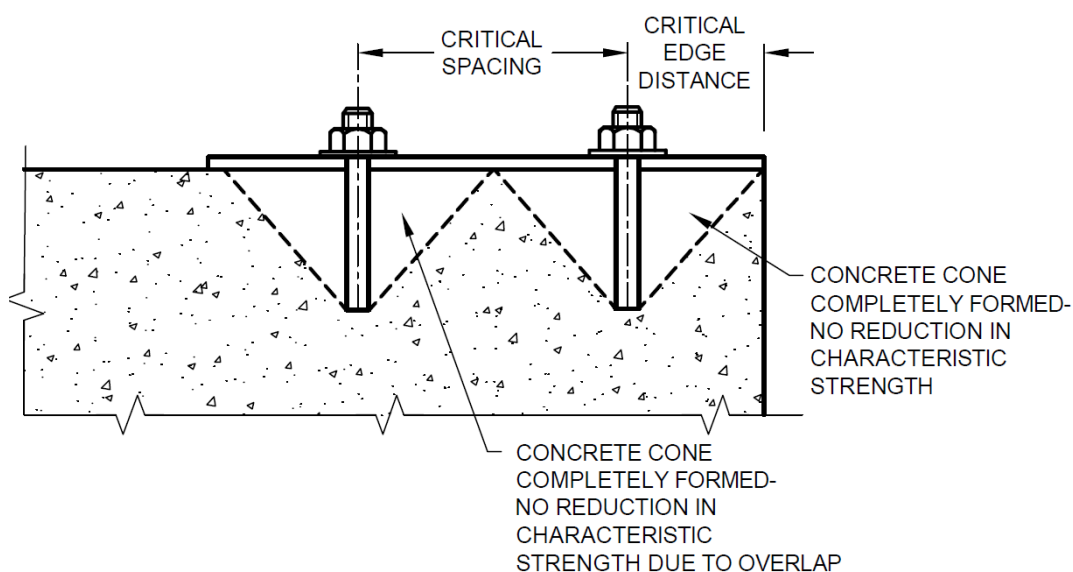

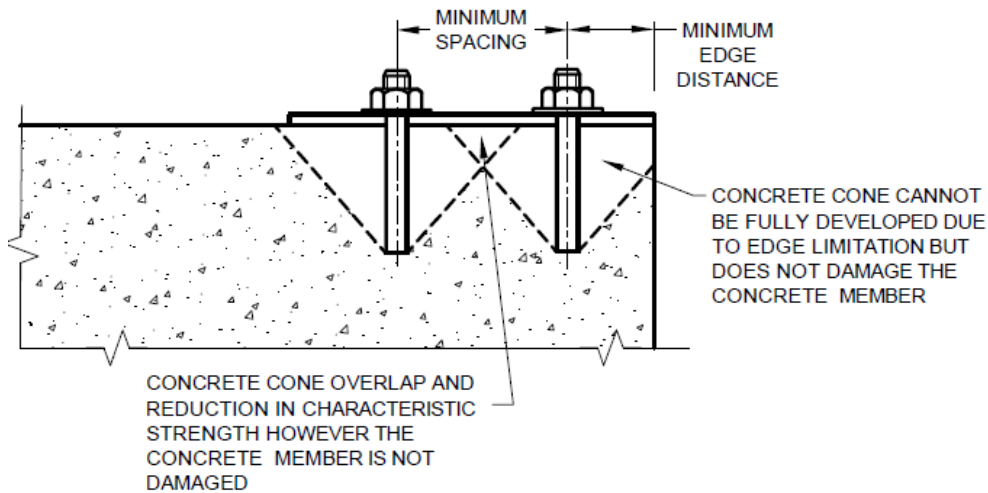

FIG. 3 CRITICAL AND MINIMUM EDGE DISTANCE

3.14 Embedment depth

3.14.1 Effective embedment (h_{ef}) – The effective depth which actually transfers the forces in the anchor into the concrete.

3.14.2 Nominal embedment – The depth at which the bottom of the anchor rests in the drilled hole of the concrete.

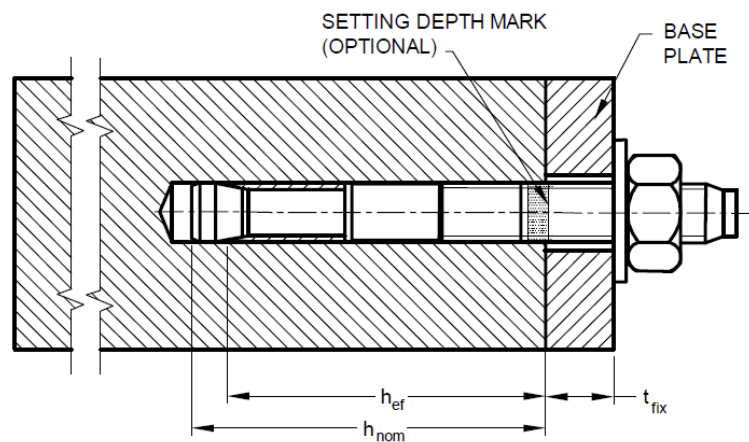

FIG. 4 EFFECTIVE AND NOMINAL EMBEDMENT DEPTH

3.15 Hole Clearance – Gap in the base plate between the anchor and plate.

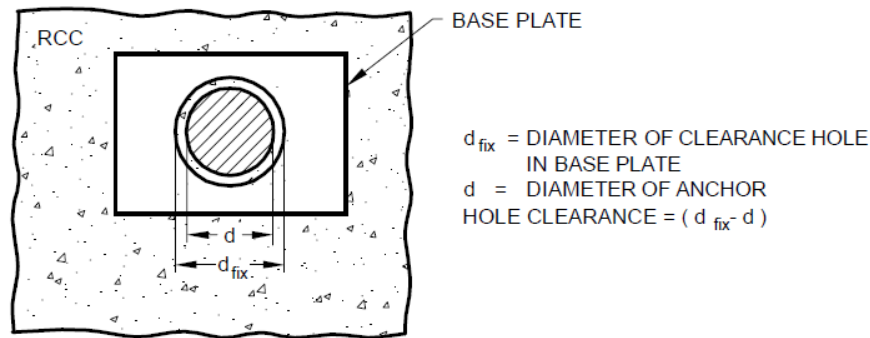

FIG. 5 HOLE CLEARANCE

3.16 Mechanical Interlock – A load transfer mechanism in which the load is transferred to a concrete member via interlocking surfaces.

3.17 Post Installed Anchors – A type of anchor in which the anchor is installed into cured and hardened concrete. It can transfer applied loads through friction, keying, adhesion or a combination of these working principles (see Fig. 6). Post-installed anchors are broadly divided in two categories – Mechanical anchors and Adhesive anchors.

3.18 Prying force – The additional tensile force which is developed in the anchors due to deformation of the base plate and deformation of anchors.

3.19 Reference Expansion – The expansion achieved by applying specified expansion energy.

3.20 Spacing – The center to center distance between the anchors.

3.20.1 Critical Spacing – The spacing between anchors at which there is no influence of spacing on its characteristic strength (see Fig. 23).

3.20.2 Minimum Spacing – The minimum spacing at which the anchor can be installed without damaging the base material (see Fig. 23).

NOTES

- 1 The critical spacing is reflected in as the actual projected concrete cone area of the anchorage at the concrete surface. The critical dimension is representative of the idealized condition where presence of adjacent anchors does not influence the resistance of an anchor in a group.
- 2 Minimum spacing is the minimum dimension needed to ensure the concrete is not damaged during installation. This minimum spacing is less than the critical dimension. In such cases, the presence of adjacent anchors reduces the resistance of an anchor in a group.

3.20 Stretch Length – The length of the anchor that extends beyond concrete surface in which it is anchored.

3.21 Technical Assessment Document (TAD) – A uniform technical specification developed by the approval body which lays down the procedure to qualify and assess a product for a specific application or use (and refers to a designated design method, if applicable)

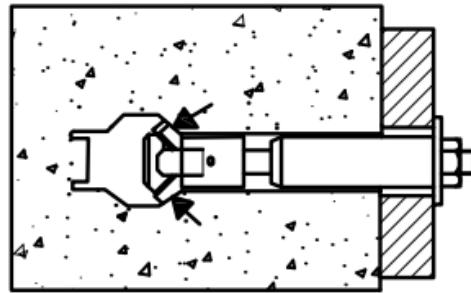

(6A) LOAD TRANSFER DUE TO FRICTION & KEYING BETWEEN METAL PARTS & CONCRETE.

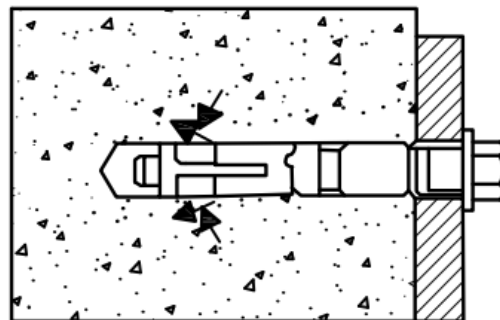

(6B) LOAD TRANSFER DUE TO MECHANICAL INTERLOCK (BEARING) BETWEEN METAL PART & CONCRETE.

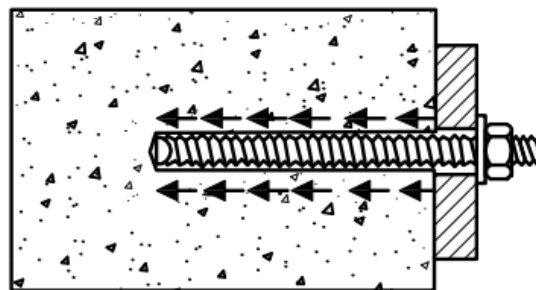

(6C) LOAD TRANSFER DUE TO BOND BETWEEN METAL PARTS & ADHESIVE AND BETWEEN CONCRETE & ADHESIVE

FIG. 6 TYPICAL LOAD TRANSFER MECHANISM OF POST-INSTALLED ANCHORS

4 TYPES OF POST INSTALLED ANCHOR

4.1 Adhesive Anchor

It consist of threaded anchor rods or reinforcement bars, which are anchored in pre-drilled holes in hardened concrete by bonding the metal parts of the anchor/reinforcement to the sides of the drilled hole with an adhesive. The adhesives used comprise of chemical components formulated from organic polymers (like,

epoxies, polyurethanes, etc.), inorganic materials (usually cementitious) that hardens on curing. Tensile loads are transmitted to the concrete through bonding between metal parts and adhesive, and between adhesive and concrete face of the drilled hole (see Fig. 7).

NOTE – While deciding the use of adhesives, comprised particularly of organic polymers, their temperature range is needed to be accounted for as per the temperature of the base material at the time of installation and expected application during its service life.

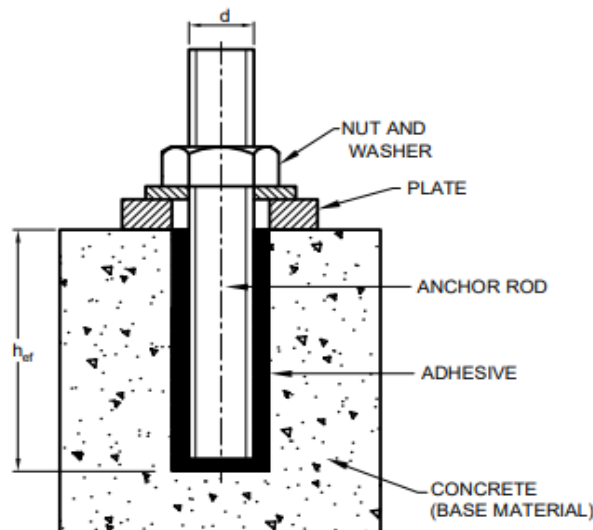

FIG. 7 ADHESIVE ANCHOR

4.1.1 Special Type Of Adhesive Anchor

- a) **Torque-controlled Adhesive Anchor** – A type of adhesive anchor designed such that its outward/upward movement relative to the hardened adhesive compound results in a follow-up expansion of the adhesive. The working principle is triggered by application of torque (see Fig. 8)

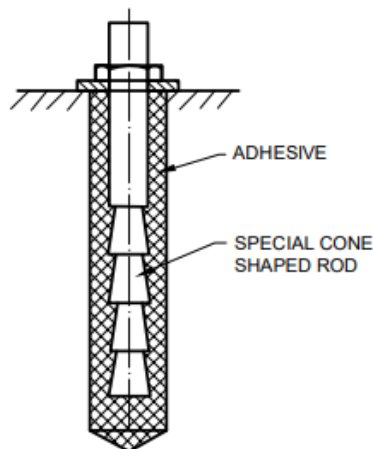

FIG. 8 TYPICAL TORQUE-CONTROLLED ADHESIVE ANCHOR

- b) **Undercut Adhesive Anchor** – A type of adhesive anchor. It combines the undercut concept of mechanical anchor with bonding mechanism of adhesive anchor (see Fig. 9).

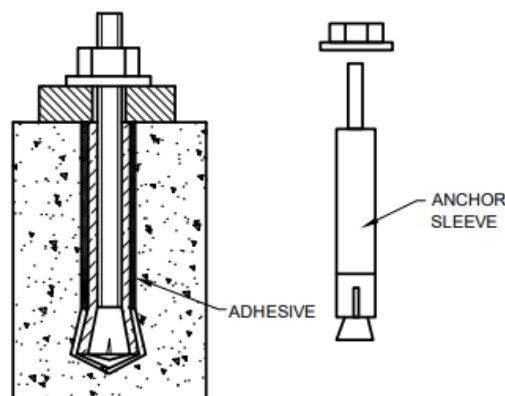

FIG. 9 TYPICAL UNDERCUT ADHESIVE ANCHOR

4.1.2 Adhesive Anchor Types Based On Dispensing Technique – Adhesive anchor systems are classified into bulk, capsule type and cartridge type adhesive anchoring systems.

- a) **Bulk Adhesive Anchor System** – This is one of the systems for large application for installing adhesive anchors. This system comprises of two-component adhesive (resin and hardener) that are supplied either in barrels or cans. These incorporate bulk dispensing and mixing machine whereby preset quantities of the components are automatically controlled during dispensing (see Fig. 10).

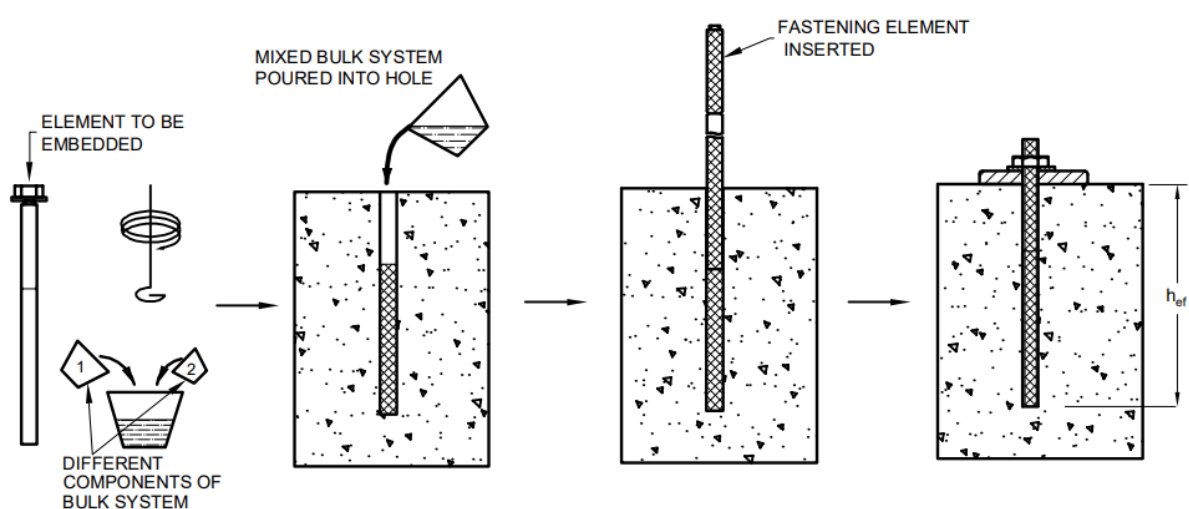

FIG. 10 TYPICAL BULK ADHESIVE SYSTEM

- b) **Capsule Adhesive Anchor System** – This is one of the systems of installing adhesive anchors. In this system, the adhesive is packaged in glass or foil

capsules. The diameter of capsule corresponds approximately to nominal anchor diameter. The quantity of resin and hardener in each capsule is such that it is suitable for single anchor application. Mixing of various components in each capsule is achieved during anchor installation process. The capsule gets fragmented, and it becomes part of the hardened resin matrix during anchor installation process (see Fig. 11).

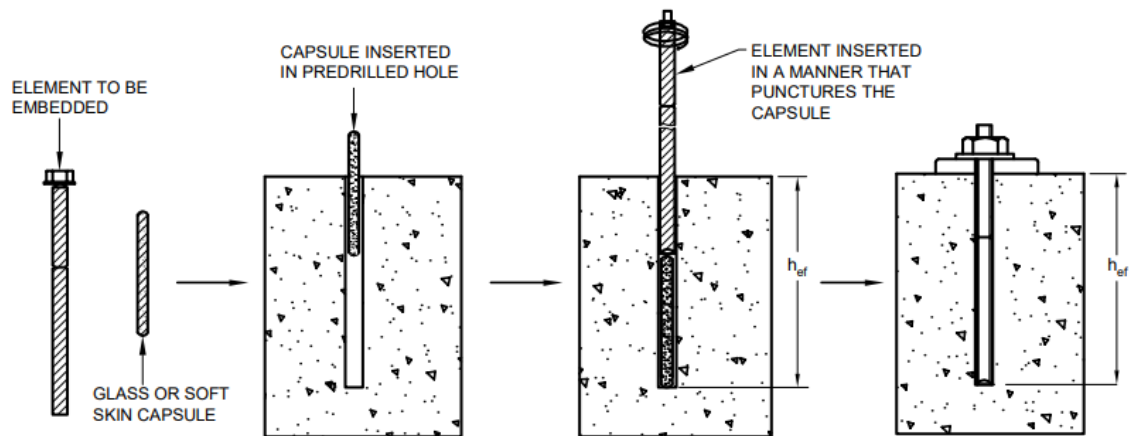

FIG. 11 TYPICAL CAPSULE ADHESIVE SYSTEM

- c) **Cartridge Adhesive Anchor System** – This is one of the systems of installing adhesive anchors. In this system, two-component adhesives (resin and hardener) are packaged in cartridges for use with either manually- or power-driven dispensers. Metering and mixing of the components is automatically controlled as the adhesive is dispensed through a manifold and disposable mixing nozzle (see Fig. 12).

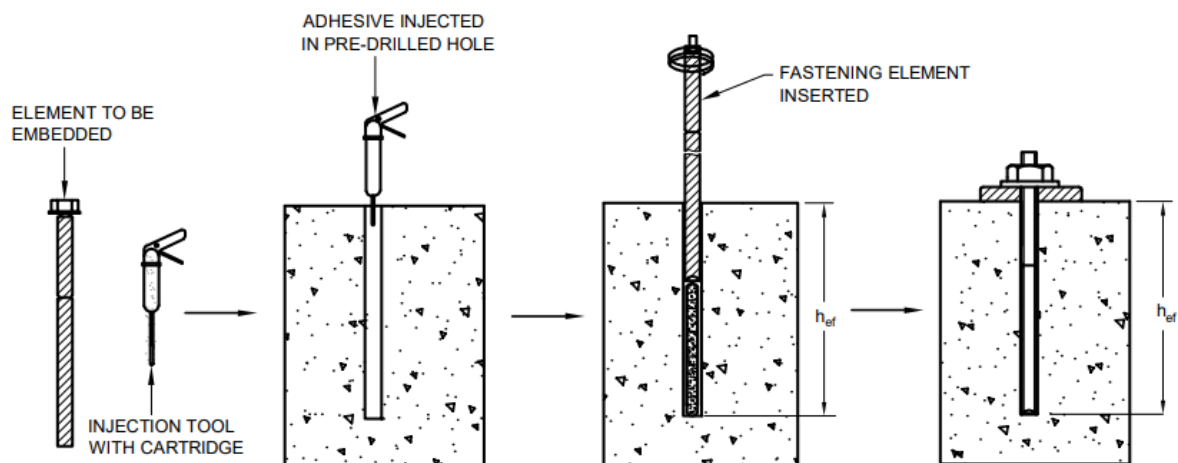

FIG. 12 TYPICAL CARTRIDGE ADHESIVE SYSTEM

4.2 Mechanical Anchor

Mechanical anchors typically transfer load to concrete through friction, keying, mechanical interlocking, or combination of any of these three working principles. The

post- installed mechanical anchoring systems are further subdivided into three categories – concrete screws, expansion anchors and undercut anchors, depending on their working principles.

4.2.1 Concrete Screw

A type of post-installed anchor with threads that are screwed into a predrilled hole where threads create a mechanical interlock with the concrete (see Fig. 13)

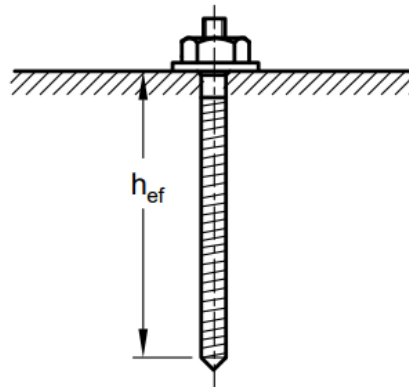

FIG.13 TYPICAL CONCRETE SCREW

4.2.2 Expansion Anchors

A type of post-installed mechanical anchor. They are anchored in predrilled holes in hardened concrete by forced expansion of sleeve. A tensile force applied to the anchor is transferred to the concrete by friction and some keying between an expanded sleeve and the concrete. Expansion anchors can be broadly classified into two types - Displacement-controlled expansion anchor [see Fig. 14(a)] and Torque-controlled expansion anchor [see Fig. 14(b)].

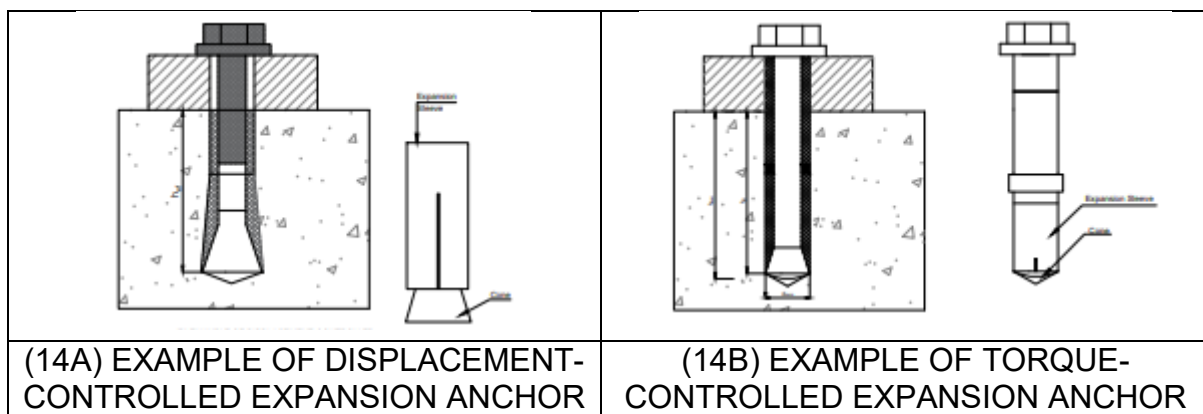
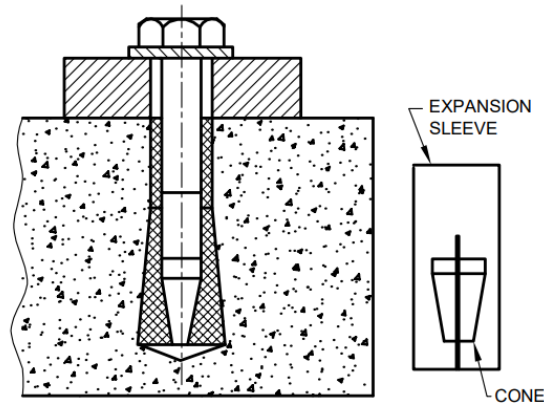

FIG. 14 DIFFERENT TYPES OF EXPANSION ANCHORS.

4.2.2.1 Displacement-controlled expansion anchor

A type of mechanical expansion anchor. It is set by expansion against the sides of the drilled hole through movement of an internal plug in the sleeve or through movement of the sleeve over an expansion element (like plug). This is achieved by driving through hammer blows or by percussion of a machine. Once set, no further expansion can occur. Displacement-controlled expansion anchors are installed by hammer blows or by percussion of a machine. In some types of displacement-controlled expansion anchors, the sleeve is expanded by driving in a cone; the extent of expansion in this case is controlled by the length of travel of the cone [see Fig. 15(a)]. In other types, the sleeve is driven over an expansion element, wherein the extent of expansion is controlled by the travel of the sleeve over the expansion element [see Fig. 15(b)]. The expansion forces created during anchor installation along with tension forces are transferred into the concrete mainly by friction. Some of the common types of displacement-controlled expansion anchors are – Cone down type anchor like drop-in anchor [see Fig. 15(c)], sleeve-down type anchor [see Fig. 15(d)] and Stud version of sleeve-down type anchor [see Fig. 15(e)].



(15A) EXPANSION BEING CONTROLLED BY LENGTH OF TRAVEL OF THE CONE.

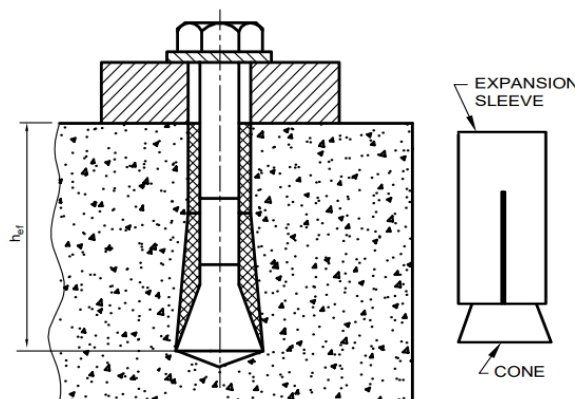

(15B) EXAMPLE OF DISPLACEMENT-CONTROLLED EXPANSION ANCHOR.

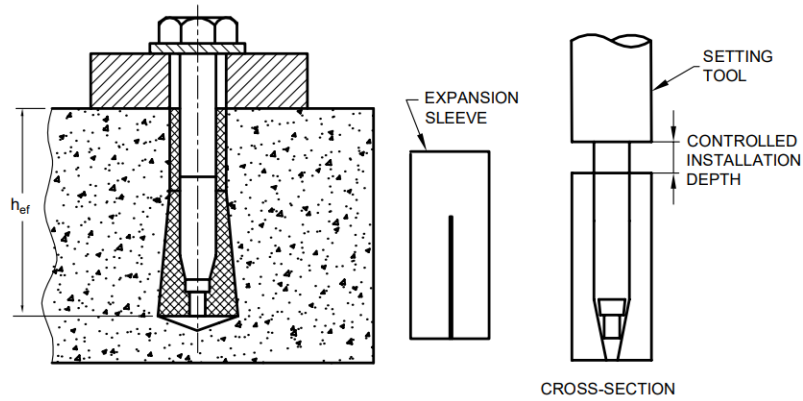

(15C) CONE-DOWN TYPE ANCHOR.

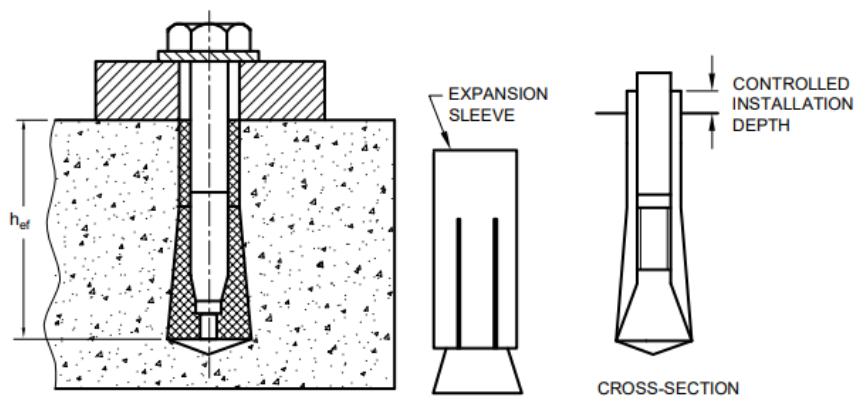

(15D) SLEEVE-DOWN TYPE ANCHOR DRILLING CONTROLLED BY STOP-DRILL BIT.

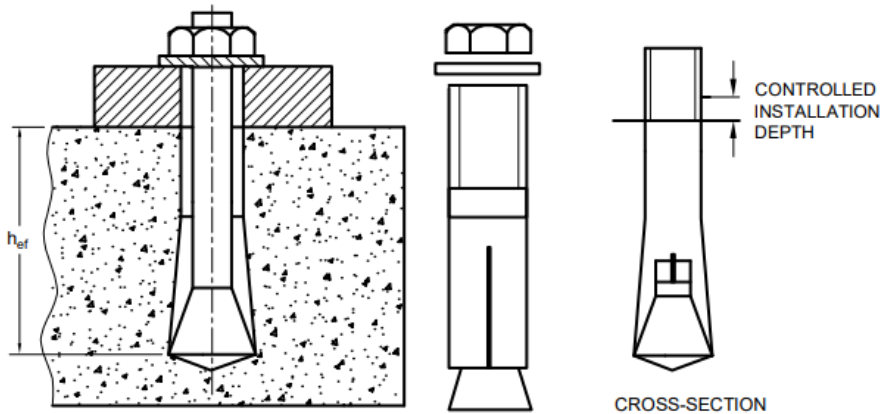

(15E) STUD VERSION OF SLEEVE-DOWN TYPE ANCHOR.

FIG.15 DISPLACEMENT-CONTROLLED EXPANSION ANCHORS.

4.2.2.2 Torque-controlled expansion anchor

A type of mechanical expansion anchor. It is set by the expansion of one or more sleeves or other elements against the sides of the drilled hole through the application of torque, which pulls the cone(s) into the expansion sleeve(s). Tensile loading can cause additional expansion (follow-up expansion) after setting up of anchor. Some of the common types of torque-controlled expansion anchors are sleeve type expansion anchors with one cone [see Fig.16 (a)] or more than one cone, bolt type expansion anchors with one cone [see Fig. 16 (b)] or more than one cone and combination of sleeve and bolt type.

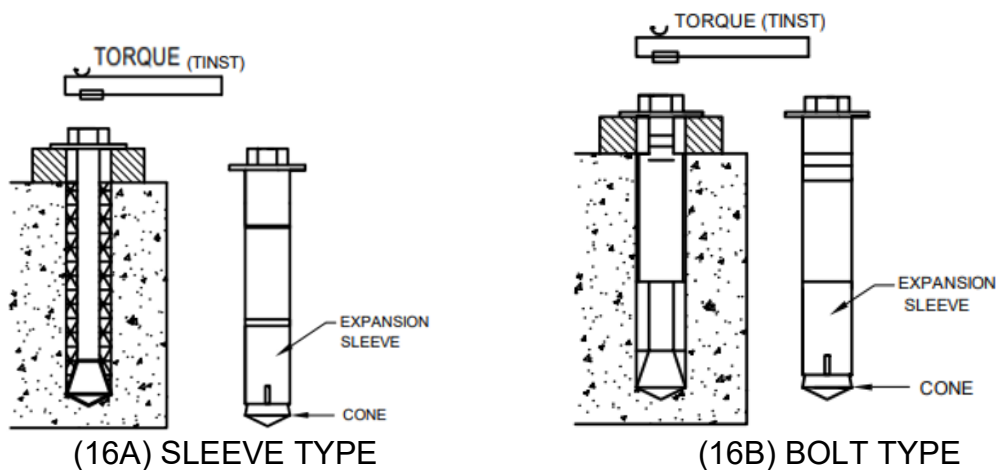

FIG. 16 TYPICAL TORQUE-CONTROLLED EXPANSION ANCHOR

4.2.2 Undercut anchor

A type of mechanical anchor. It is anchored by mechanical (bearing) interlock provided by an undercut in the concrete. It is a type of anchor which derives its strength from mechanical interlock provided by an undercut in the concrete at the embedded end of the anchor. The undercutting in undercut anchors may be achieved by:

- a) Hammering or turning (or both) the anchor sleeve into a drilled undercut hole.
- b) Hammering or turning (or both) the anchor sleeve on to the tapered bolt in a cylindrical hole. In this case, the concrete is mostly cut away rather than compressed.

Installation of undercut anchors can be sub-divided into displacement-controlled installations and torque-controlled installations. In case of displacement-controlled installations, the holes are drilled with a stop-drill to ensure correct installation depth for anchors. In case of torque-controlled installations, the expansion is controlled by defined torque moment (see Fig. 17).

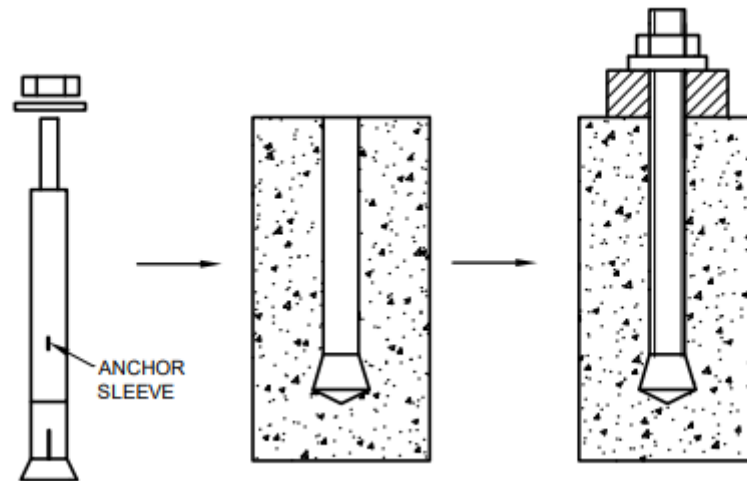

(17A) UNDERCUT ANCHOR THAT REQUIRES UNDERCUT TO BE CREATED TO INSTALLATION

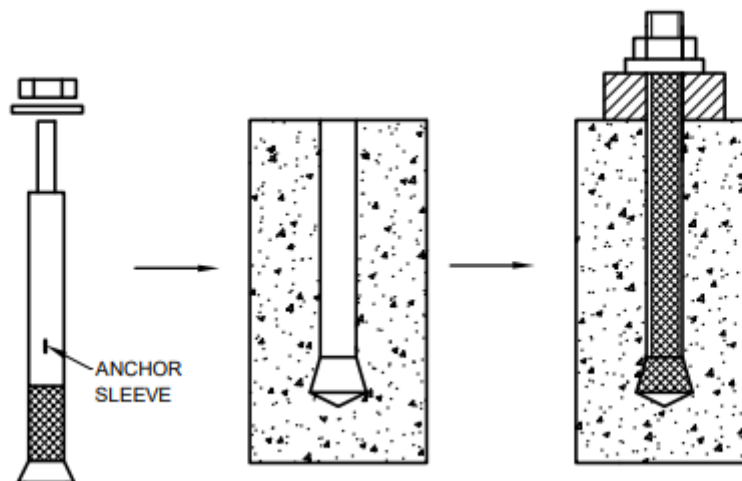

(17B) UNDERCUT ANCHOR THAT DOES NOT REQUIRE UNDERCUT TO BE CREATED PRIOR TO INSTALLATION.

FIG. 17 TYPICAL UNDERCUT (MECHANICAL) ANCHOR

NOTES

- 1 The selection of the appropriate type of anchor shall be governed by multiple factors like condition of the existing concrete, area of application, type of load, magnitude of load, feasibility of application. For example in a poorly compacted concrete, for high tension load or for close to the edge applications, adhesive anchors may be preferred. For high shear dominated applications, mechanical anchors may be preferred. However, this is not restrictive in nature as to use of the anchors. The selection may be made by the concerned structural engineer and confirmed by the manufacturer.
- 2 Special care must be exercised while designing post installed anchors in case of fire and the characteristic resistance of the anchor as per the assessment report of the anchor corresponding to the given fire rating shall be referred to. Design of anchor for fire is out of scope of this standard.

5 FAILURE MODES OF POST INSTALLED ANCHORS

5.1 Bond Failure

A failure type observed for adhesive anchors in tension. This failure occurs either at the interface between the adhesive and the base material or between the adhesive and the embedded element (like threaded rod) of the adhesive anchor. This failure is typically accompanied with a shallow concrete cone at the loaded end of anchor. Bond failure is a sub type of pullout failure which is applicable only for adhesive anchors (see Fig. 18)

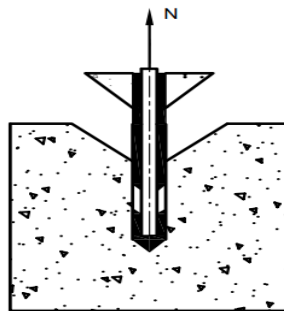

(18 A) BOND FAILURE BASE MATERIAL AND ADHESIVE INTERFACE

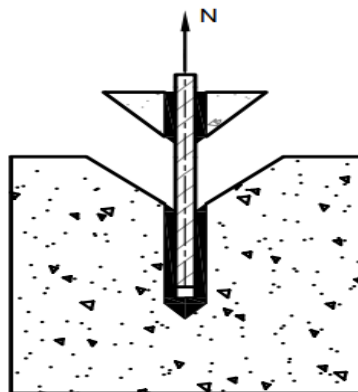

(18 B) BOND FAILURE AT ADHESIVE AND EMBEDDED ELEMENT INTERFACE

FIG. 18 BOND FAILURE

5.2 Concrete Cone Failure

This failure type is typically observed in both mechanical and adhesive anchors installed at shallow embedment depths under tension loading. This failure mechanism is characterized by the formation of a conical fracture surface originating at or near the embedded end of the anchor element and projecting to the surface of the concrete member. This failure mode is also observed in groups of mechanical and adhesive anchors installed at less than critical spacing. This type of failure can also occur when the anchor is located at a distance less than the critical distance (see Fig. 19).

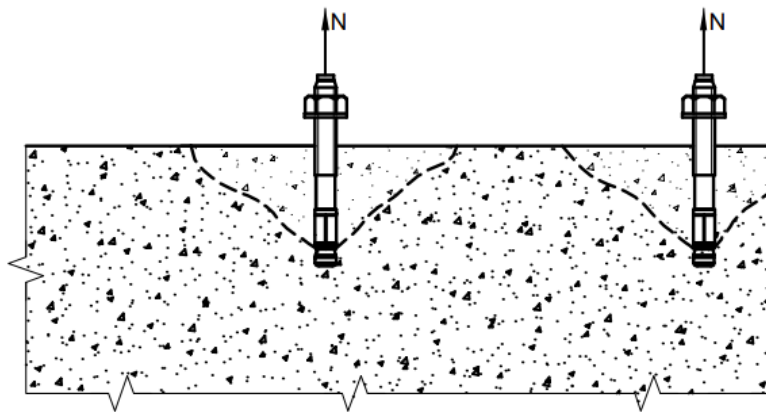

FIG. 19 TYPICAL CONCRETE CONE FAILURE

5.3 Concrete Edge Failure

This failure type is observed for both mechanical and adhesive anchors installed at less than critical edge distance under shear loading (with shear acting towards the free edge) (see Fig. 20).

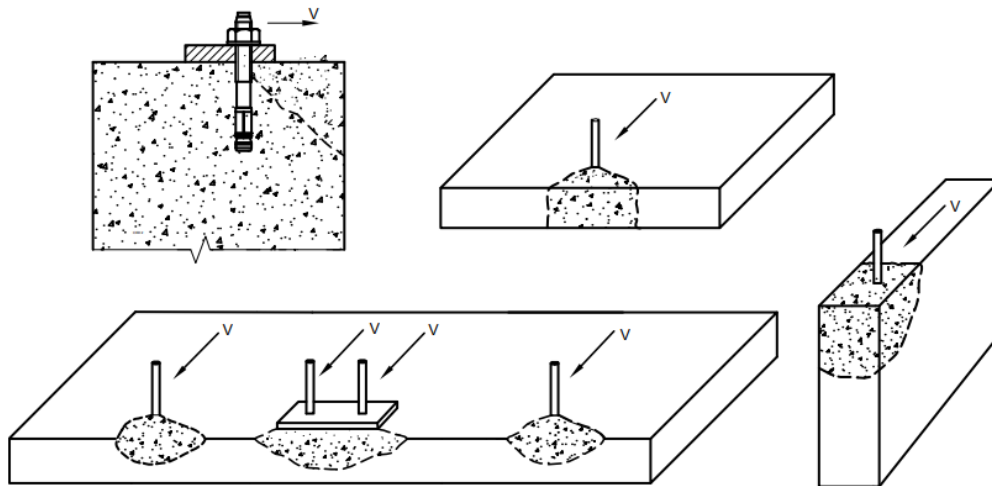

FIG. 20 TYPICAL CONCRETE EDGE FAILURE

5.4 Concrete Pry-out Failure

This failure type is observed for both mechanical and adhesive anchors installed at shallow embedment under shear loading (see Fig. 21). Concrete pry-out failure corresponds to the formation of a concrete spall opposite to the loading direction under shear loading.

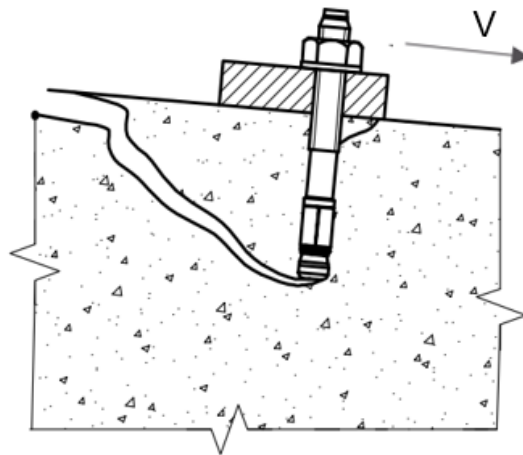

FIG. 21 TYPICAL CONCRETE PRY-OUT FAILURE

5.5 Pull-out Failure

This failure type is observed for mechanical anchors under tension loading. It is characterized by the withdrawal of the anchor element from the concrete without rupture of the embedded part. The formation of limited-depth conical breakout surfaces are also considered as pullout failures (see Fig. 22).

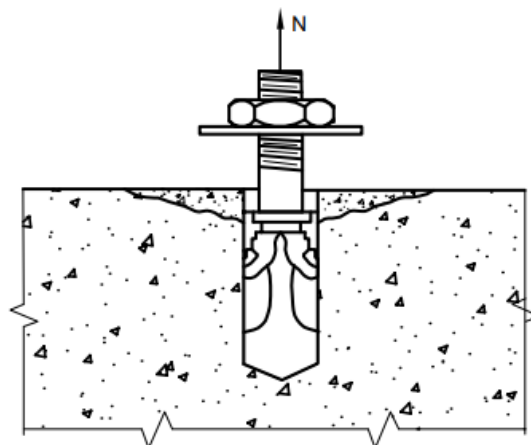

FIG. 22 TYPICAL PULL-OUT FAILURE

5.6 Pull-through Failure

This failure type is observed for mechanical anchors under tension loading in which the anchor body pulls through the expansion sleeve without development of the full steel or concrete capacity (see Fig. 23).

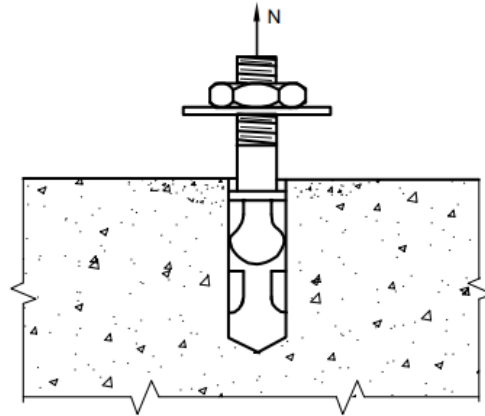

FIG. 23 TYPICAL PULL-THROUGH FAILURE

5.7 Splitting Failure

This failure type is observed for both mechanical and adhesive anchors installed in a 'thin' concrete member under tension loading. It is essentially a concrete failure mode in which the concrete fractures along a plane passing through the axis of the anchor or anchor group (see Fig. 24).

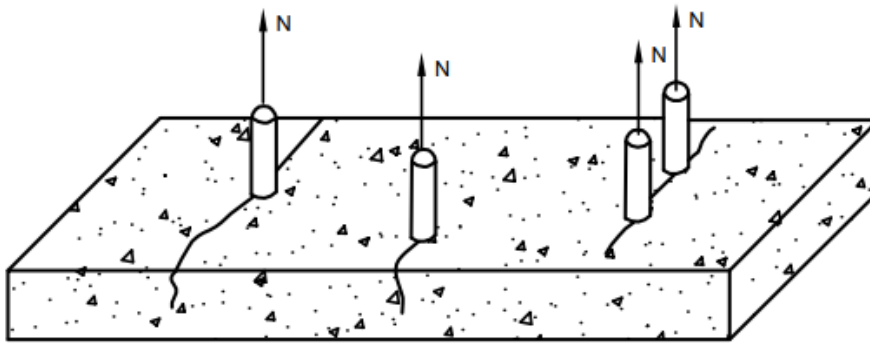
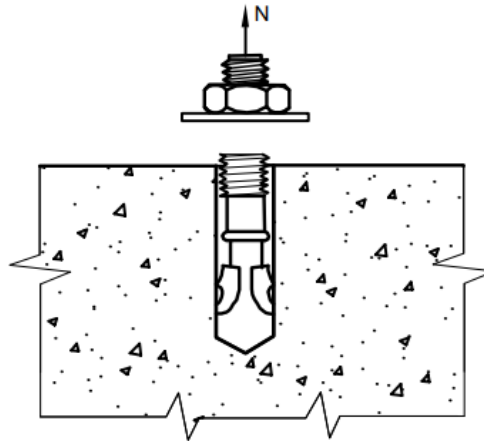

FIG. 24 TYPICAL SPLITTING FAILURE

5.8 Steel Failure

This failure mode is observed for both mechanical and adhesive anchors under tension or shear loading. In this failure type, the steel anchor parts are fractured (see Fig 25).



(25 A) STEEL FAILURE IN TENSION

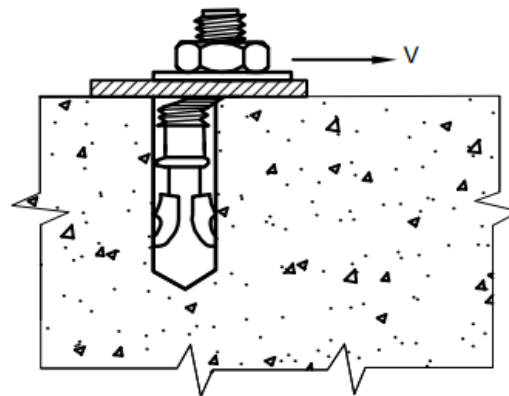

(25 B) STEEL FAILURE IN SHEAR

FIG. 25 TYPICAL STEEL FAILURE

6 SYMBOLS AND NOTATIONS

For the purpose of this standard, the following letter symbols shall have the meaning indicated against each; where other symbols are used, they are explained at the appropriate place.

6.1 Suffixes

a	—	Anchor
c	—	Concrete
cp	—	Concrete pry-out
cr	—	Critical
cr'	—	Cracked
d	—	Design value
g	—	Group
H	—	Horizontal
i	—	Individual
inst	—	Installation

L	—	Load
M	—	Material
m	—	Mean
mod	—	modified
p	—	Pull-out / Pull-through
red	—	Reduced
Rk	—	Characteristic value
s	—	Steel
seis	—	Seismic/ earthquake
sp	—	Splitting
u	—	Ultimate
uncr'	—	Uncracked
V	—	Vertical
y	—	Yield
σ^*	—	Most stressed
0	—	Basic or idealized
X	—	In direction X
Y	—	In direction Y

6. 2 Symbols and Notations

A	—	Area
A_s	—	Stressed cross section area of steel
E_s	—	Modulus of elasticity of steel
E_c	—	Modulus of elasticity of concrete
c'	—	Distance of anchor from its center to edge of concrete member
c'_1	—	Distance of anchor from its center to edge in direction 1; c'_1 is the edge distance in direction of the shear load for anchorages close to an edge loaded in shear
c'_2	—	Distance of anchor from its center to edge in direction 2; direction 2 is perpendicular to direction 1
$c'_{cr,N}$	—	Critical edge distance of an anchor for concrete cone failure
$c'_{cr,Np}$	—	Critical edge distance of an anchor for bond / pull-out failure.
$c'_{cr,sp}$	—	Critical edge distance of an anchor for splitting failure
c'_{min}	—	Minimum edge distance of an anchor
d_a	—	Anchor diameter of anchor bolt or thread diameter (in case of internally threaded sockets outside diameter of socket)
D	—	concrete member or base material thickness
d_{fix}	—	Diameter of clearance hole in base plate
D_{min}	—	Minimum thickness of concrete member in which the anchor can be installed without damaging the concrete member
d_{nom}	—	Outside diameter of anchor
d_0	—	Drill hole diameter
e_N	—	Eccentricity of the resulting tensile load acting on the tensioned anchors w.r.t center of gravity
e_V	—	Eccentricity of the resulting shear load acting on the anchors w.r.t center of gravity
F	—	Force

f_{ck}	— Characteristic cube compression strength of concrete (measured on cube with side length of 150 mm)
f_y	— Yield strength of steel
f_u	— Ultimate tensile stress for steel
$F_{k,sp}$	— Splitting force
h_{ef}	— Effective anchorage/ embedment depth
I_p	— Radial moment of inertia
M	— Moment
N	— Normal force; positive in tension, negative in compression
n	— Number of anchors in an anchor group
N_{Ld,σ^*}	— Design load on most stressed anchor of group
R	— Strength or resistance
s'	— Spacing of anchor in an anchor group
s'_1	— Centre-to-center spacing of anchors in an anchor group in direction 1
s'_2	— Centre-to-center spacing of anchors in an anchor group in direction 2
$s'_{cr,N}$	— Critical spacing between anchors for concrete cone failure
$s'_{cr,Np}$	— Critical spacing between anchors for bond pullout failure
$s'_{cr,sp}$	— Critical spacing between anchors for splitting failure
s'_{min}	— Minimum spacing between anchors
T	— Torsion
V	— Shear force
Z_{el}	— Elastic section modulus of anchor calculated from the stressed cross section of steel ($\pi d^3 / 32$)
τ	— Bond strength
σ_L	— Stress (taken as positive, if tension) in the concrete induced by external loads, including anchors loads
σ_R	— Stress (taken as positive, if tension) in the concrete due to restraint of intrinsic imposed deformations or extrinsic imposed deformations
α_{gap}	— Reduction factor to account for inertia effects due to a gap between anchor and base plate in shear
α_M	— Factor to account for degree of fixity of the anchor
α_{seis}	— Reduction factor to account for the influence of large cracks and scatter of load-displacement curves under earthquake conditions
α_V	— Angle between shear load on anchors and a line perpendicular to the edge for which the verification for concrete edge failure is being carried out
γ_f	— Partial safety factor for load
γ_c	— Partial safety factor for concrete
γ_{inst}	— Partial safety factor for installation
γ_M	— Partial safety factor for material
γ_{Mc}	— Partial safety factor for concrete failure types (cone failure, pull-out /pull-through failure, concrete pry-out failure, concrete edge failure)
γ_{Mp}	— Partial safety factor for bond failure
γ_{Msp}	— Partial safety factor for splitting failure
γ_{Ms}	— Partial safety factor for steel failure
l	— Lever arm of shear load

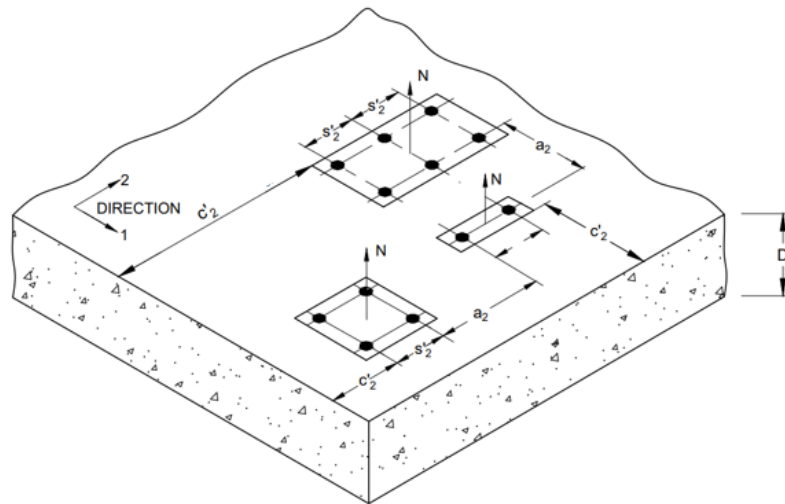

(26A) ANCHOR GROUPS SUBJECTED TO TENSILE LOAD

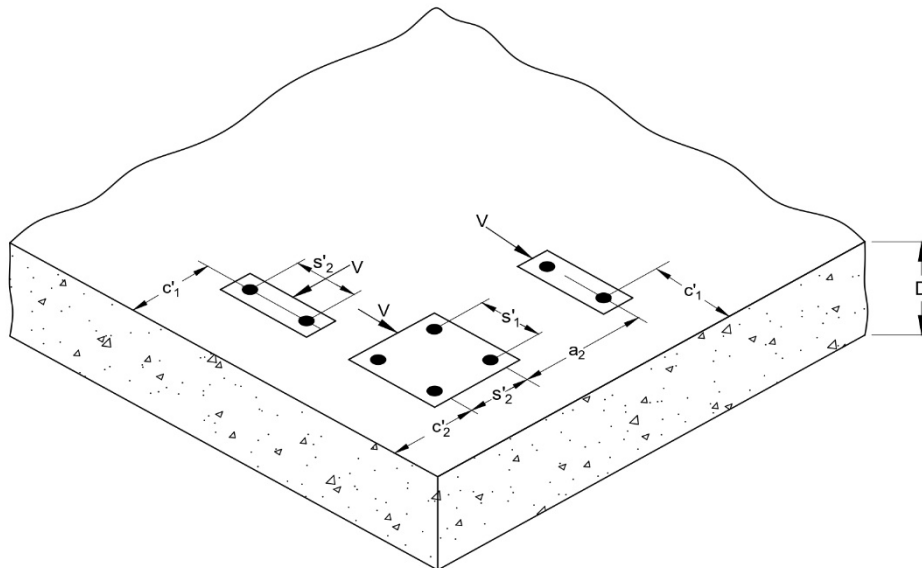

(26B) ANCHOR GROUPS SUBJECTED TO SHEAR LOAD

FIG. 26 NOTATIONS AND SYMBOLS

7 ANCHORS AND ANCHOR GROUP CONFIGURATIONS

The connection in a structure shall be designed so as to be consistent with the assumptions made in analysis of the structure and comply with requirements specified in this standard. The connections shall be capable of transmitting the calculated design loads in tension, shear or combined tension and shear. A suitable grouting material of sufficient compressive strength (non-shrink cementitious grout based) shall be provided between the concrete surface and the base plate. The thickness of the grouting material shall be such that it does not create any stand-off between the base material and the plate.

7.1 Anchor

The anchors may be subjected to tension, shear, or combination of both and bending (in case of stand-off). The anchors are not considered to transfer any compression force. The anchors may be made of suitable materials such as carbon steel, stainless steel or malleable cast iron. The anchors may include non-load bearing material such as plastic parts for rotation prevention.

NOTE – Undercut adhesive anchors are not covered in this standard.

7.2 Anchor Diameter and Embedment

7.2.1 The anchors shall have a minimum diameter of 6 mm.

7.2.2 For mechanical anchors, the embedment depth of the anchor shall be at least 6 times the anchor diameter, but not less than 40 mm. For fastening statically indeterminate non-structural elements, minimum embedment depth of anchor shall be 30 mm.

7.2.3 For adhesive anchors, the maximum embedment depth for design of the anchor shall be 20 times the anchor element diameter. Any embedment depth in excess of 20 times diameter shall be ignored in design calculation. The minimum embedment depth (h_{ef}) shall be as follows:

For

$d_a \leq 10 \text{ mm},$	$h_{ef} = 60 \text{ mm}.$
$d_a = 12 \text{ mm},$	$h_{ef} = 70 \text{ mm};$
$d_a = 16 \text{ mm},$	$h_{ef} = 80 \text{ mm};$
$d_a = 20 \text{ mm},$	$h_{ef} = 90 \text{ mm};$ and
$d_a \geq 24 \text{ mm},$	$h_{ef} = 4d_a .$

7.3 Location Details of Anchors

7.3.1 Clearance Holes in Base Plate for Anchors

The diameter of clearance hole (d_{fix}) in the base plate shall not be larger than the values given below with the following exception that for an individual anchor or anchor groups loaded in pure tension, a larger diameter of the clearance hole is acceptable if a suitable washer is used.

For, $d < 10 \text{ mm}$	$d_{fix} = d + 1$
$10 \leq d \leq 24 \text{ mm}$	$d_{fix} = d + 2$
$d > 24 \text{ mm}$	$d_{fix} = d + 3$

$d = d_a$, if bolt bears against the base plate

$d = d_{nom}$, if sleeve bears against the base plate

Note – The above dimensions shall not be applicable for concrete screws. For concrete screws, reference shall be made to the AR of the anchor.

7.3.2 Permissible Anchor Group Configurations

The anchor group configurations illustrated in Fig. 27 are valid for all loading directions and all edge distances, provided the gap between anchor and plate is filled during installation. The gap shall be filled up by a suitable filling material of compatible strength.

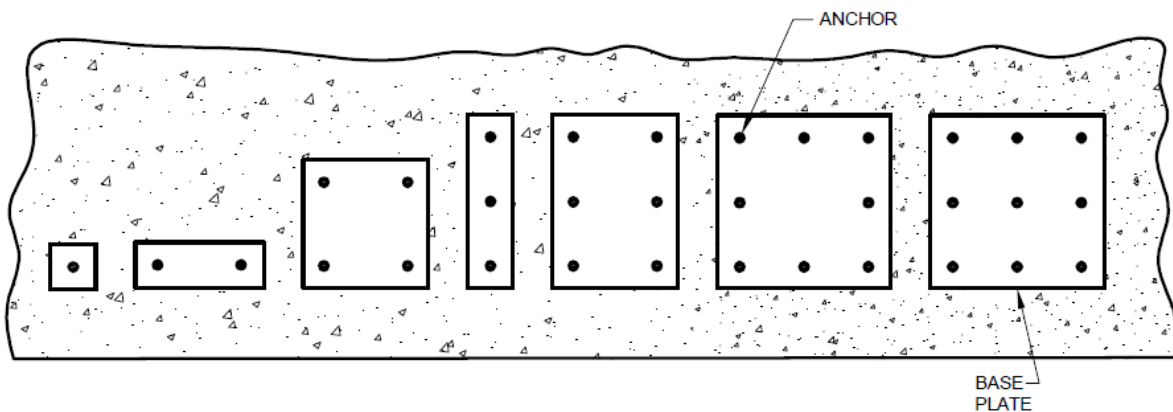

FIG. 27 ANCHOR GROUP CONFIGURATION WHEN GAPS BETWEEN THE PLATE AND THE ANCHOR ARE FILLED UP FOR ALL EDGE DISTANCE AND FOR ALL LOAD DIRECTIONS (SHEAR FORCE IS TAKEN UP BY ALL ANCHORS)

In case hole filling cannot be ensured at site, the following arrangements are allowed (see Fig. 28).

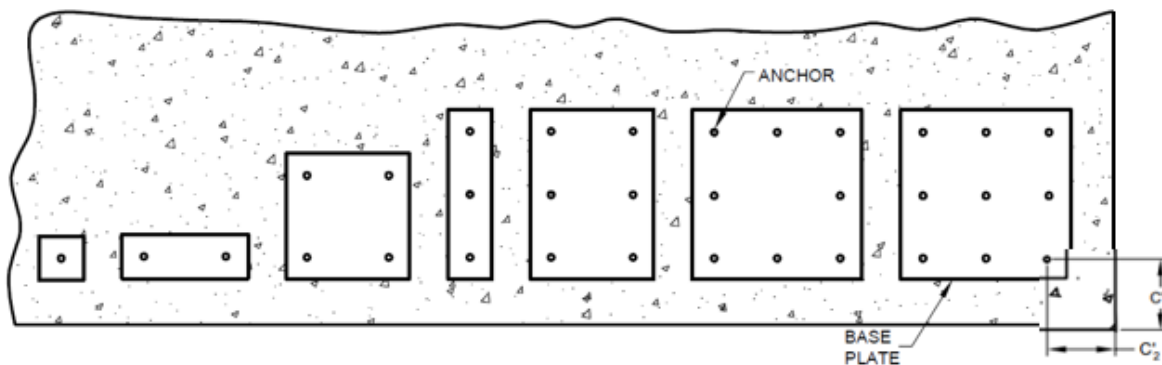

FIG. 28 ANCHORS WITH HOLE CLEARANCE ACCORDING TO 7.3.1. (WHEN GAPS BETWEEN THE PLATE AND ANCHOR ARE NOT FILLED UP) FOR ALL LOAD DIRECTIONS (SHEAR FORCE IS TAKEN UP BY THE FRONT ROW OF ANCHORS)

NOTE – Other anchor arrangements such as triangular or circular pattern may be allowed; however, the provisions of this standard should be applied with required engineering judgment in such cases.

7.4 Concrete Base Material

The concrete thicknesses required for post-installed mechanical anchors shall be at least $2h_{ef}$, but not less than 120 mm. The concrete thicknesses required for post-installed adhesive anchors shall be at least equal to $(h_{ef} + \Delta_D)$, but not less than 100 mm, Δ_D shall be taken as $2d_0$ or 30 mm whichever is larger. Concrete shall be assumed to be cracked for design purpose.

NOTE – In some cases, uncracked concrete may be assumed if under service conditions the anchor with its entire anchorage depth is located in compression zone. This will be satisfied if the following equation is observed.

$$\sigma_L + \sigma_R \leq 0$$

where, σ_L = Stress (taken as positive, if tension) in the concrete induced by external loads, including anchors loads.

σ_R = Stress (taken as positive, if tension) in the concrete due to restraint of intrinsic imposed deformations or extrinsic imposed deformations such as displacement of support and temperature variations (see IS 456).

8 STRUCTURAL ANALYSIS

Loads and moments acting on the anchorage shall be determined using general principles of structural analysis (elastic) taking into account partial safety factors.

8.1 Tension Load

8.1.1 The direct tension forces and bending moments acting on the base plate shall be resolved into tension load acting on each anchor and shall be calculated according to the theory of elasticity using the following assumptions:

a) The anchor plate shall not deform under the design loads.

NOTE – For this assumption to be valid, the anchor plate shall be sufficiently stiff. Guidance may be taken from IS 800 on steel plate design.

b) The axial stiffness ($E_s A_s$) of all anchors shall be equal, where E_s shall be taken as per structural properties of material of the anchor.

c) The anchors shall not be considered to contribute in the transmission of normal forces in the zone of compression under the base plate. The compression forces shall be assumed to be transferred to concrete through the grout layer.

d) The modulus of elasticity of concrete (E_c) shall be considered as per IS 456.

8.1.2 If the magnitude of tension force acting on individual anchors ($N_{L,i}$) of an anchor group is different, then the eccentricity e_N of the total tension force acting on the anchor group ($N_{L,g}$) shall be calculated to enable accurate assessment of strength of the anchor group (see Fig. 28).

NOTE – Prying forces may occur due to deformation of base plates and displacement of anchors, and shall be taken into account. Prying forces are avoided using rigid base plates.

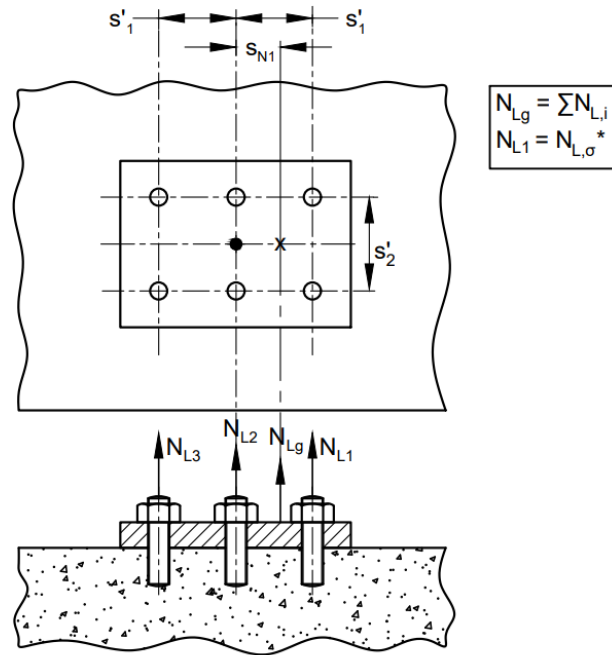

(29A) ECCENTRICITY IN ONE DIRECTION WHEN ALL ANCHORS ARE IN TENSION

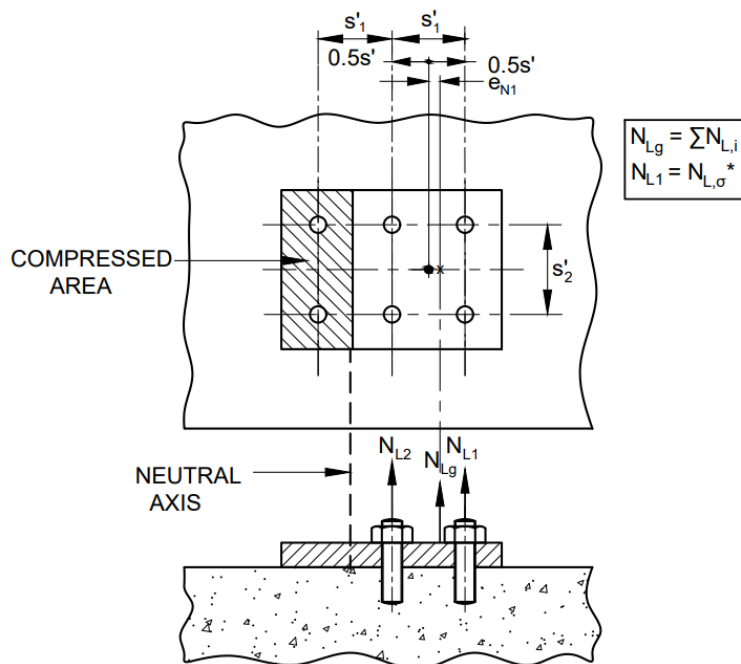

(29B) ECCENTRICITY IN ONE DIRECTION WHEN ONLY SOME OF THE ANCHORS OF AN ANCHOR GROUP ARE LOADED IN TENSION

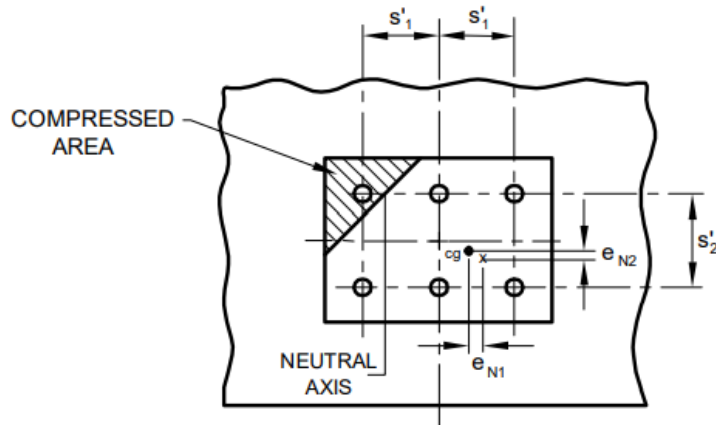

(29C) ECCENTRICITY IN TWO DIRECTIONS WHEN ONLY SOME OF THE ANCHORS OF AN ANCHOR GROUP ARE LOADED IN TENSION

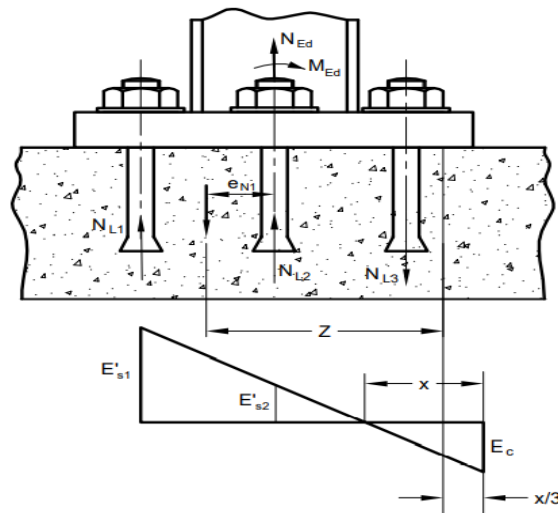

(29D) ANCHORAGE LOADED BY A BENDING MOMENT AND TENSION FORCE

Key:

- ⊕ Tensioned anchors
- Center of gravity of anchors in tension
- x Point of resulting tensile force of tensioned anchors

FIG. 29 TYPICAL ANCHOR GROUPS SUBJECTED TO ECCENTRIC LOAD

8.2 Shear Load

8.2.1 Distribution of Shear Loads

The distribution of shear loads is dependent on the effectiveness of the anchors to resist shear loads which is influenced by the hole clearance and the edge distance.

- a) In case of steel failure and concrete pry-out failure, it shall be assumed that all anchors of an anchor group will take up shear load (see Fig. 30).

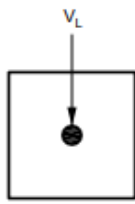

(30A) ANCHOR TAKING SHEAR LOAD

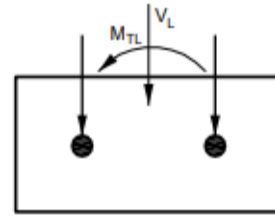

(30B) TWO ANCHORS
 SUBJECTED TO SHEAR
 SUBJECTED TO SHEAR AND
 MOMENT

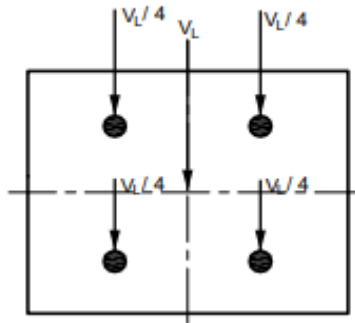

(30C) MULTIPLE ANCHORS SUBJECTED TO SHEAR

FIG. 30 EXAMPLE OF LOAD DISTRIBUTION FOR CASES WHEN ALL ANCHORS TAKE UP SHEAR LOAD

b) In case of concrete edge failure and filled clearance holes between the anchor and the base plate, it shall be assumed that all anchors take up shear forces perpendicular and parallel to the edge (see Fig. 31).

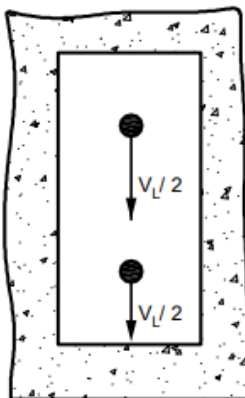

(31A) TWO ANCHOR GROUP

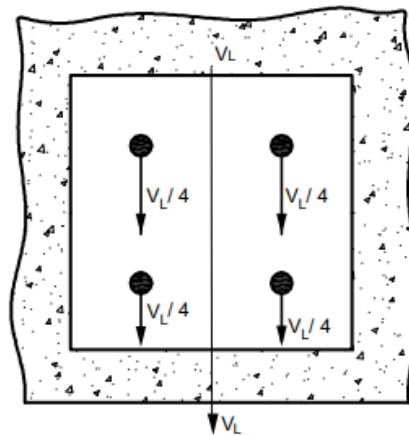

(31B) FOUR ANCHOR GROUP

FIG. 31 EXAMPLE OF DISTRIBUTION OF SHEAR LOAD - ANCHOR LOCATED NEAR THE EDGE (WHEN GAP BETWEEN THE ANCHOR AND THE BASE PLATE IS FILLED UP)

- c) In case of concrete edge failure with an unfilled clearance hole according to 7.3.1, it shall be assumed that only the most unfavorable anchor (first row of anchor) will take up shear loads acting perpendicular towards the edge (see Fig. 32). In case the shear is acting parallel to the edge then all anchors shall be assumed to take up shear load.

NOTE — The slotted holes in base plates in the direction of shear load prevent anchors from taking up shear loads and may be used in case of fastenings close to an edge (see Fig. 32). In this case, the anchors near to the edge would not take shear but other anchors can be designed for their full capacity.

For, eccentrically loaded connections, shear load transfer shall follow similar principles as above and load distribution shall be in accordance with Fig. 33.

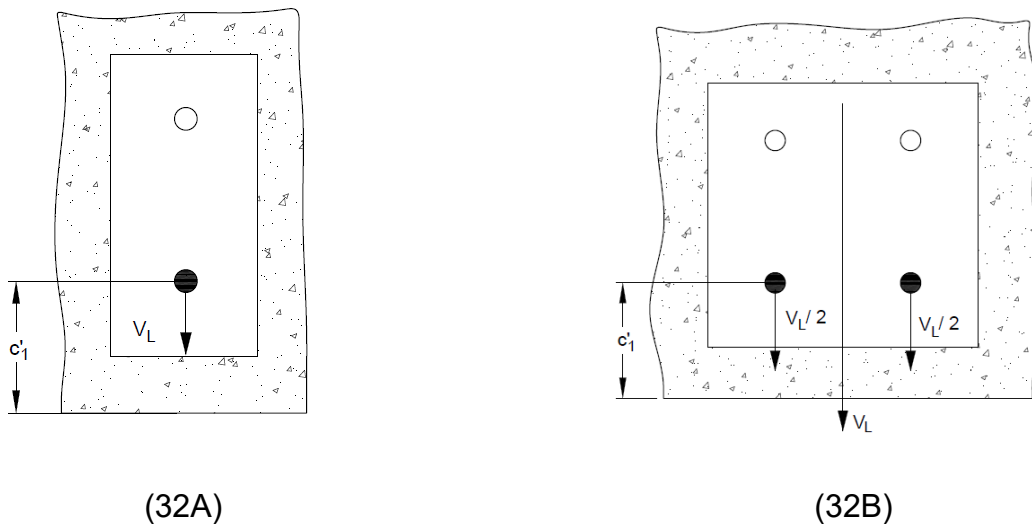

FIG. 32 EXAMPLE OF DISTRIBUTION OF SHEAR LOAD - ANCHOR LOCATED NEAR THE EDGE (WHEN GAP BETWEEN THE ANCHOR AND THE BASE PLATE IS NOT FILLED UP)

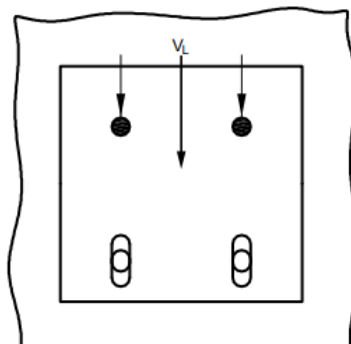

FIG. 33 EXAMPLE OF LOAD DISTRIBUTION FOR ANCHORAGE WITH SLOTTED HOLES

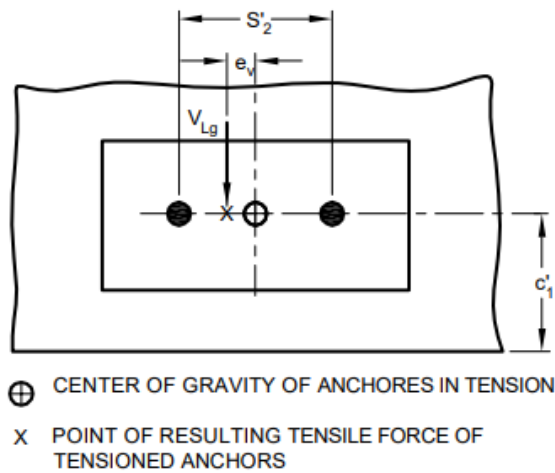
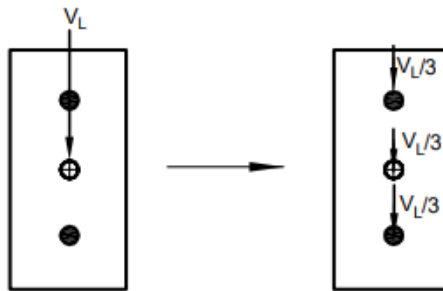

FIG. 34 EXAMPLE OF ANCHORAGE SUBJECTED TO ECCENTRIC SHEAR LOAD

8.2.2 Determination of Shear Loads

The direct shear forces and torsion acting on the base plate shall be resolved into shear load acting on each anchor and shall be calculated according to the theory of elasticity assuming equal stiffness for all anchors in an anchor group. Equilibrium shall be satisfied (see Fig. 34).



(35A) GROUP OF THREE ANCHORS SUBJECTED TO SHEAR

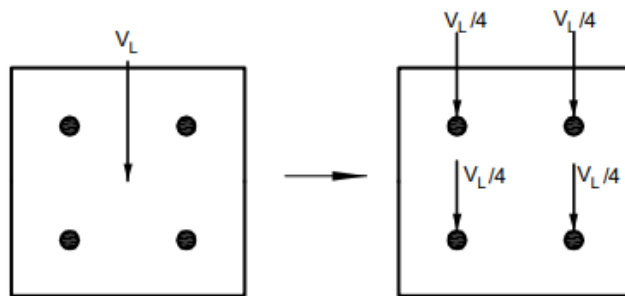

(35B) GROUP OF FOUR ANCHORS SUBJECTED TO SHEAR

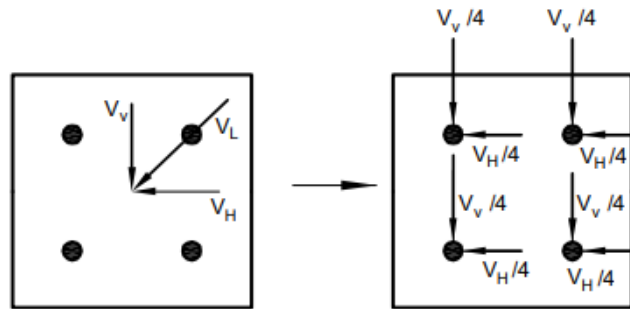

(35C) GROUP OF FOUR ANCHORS SUBJECTED TO INCLINED SHEAR

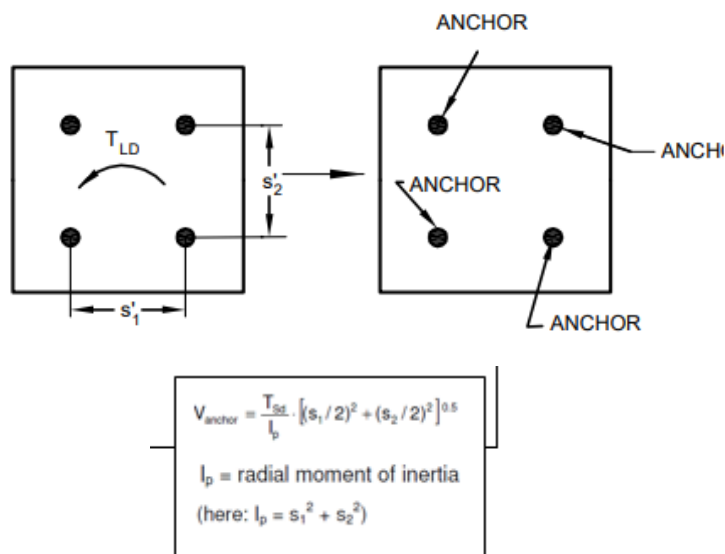

(35D) GROUP OF FOUR ANCHORS SUBJECTED TO TORSION MOMENT

FIG. 35 DETERMINATION OF SHEAR LOADS FOR CASES WHEN LOAD IS TAKEN UP BY ALL ANCHORS, IN CASE OF STEEL AND CONCRETE PRY-OUT FAILURE

In case of anticipated concrete edge failure (that is, when anchors are located close to edge), it shall be assumed that all anchors take up shear forces perpendicular and parallel to the edge, given that the gap between the anchor and base plate is filled up (see Fig. 36). In case the shear is acting parallel to the edge then all anchors shall be assumed to take up shear load.

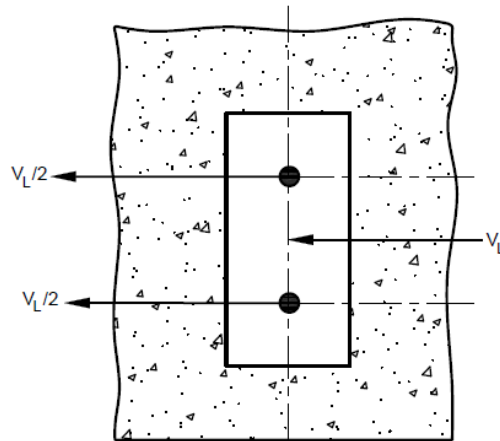

(36A) GROUP OF TWO ANCHORS WHEN LOADED IN SHEAR PARALLEL TO THE EDGE

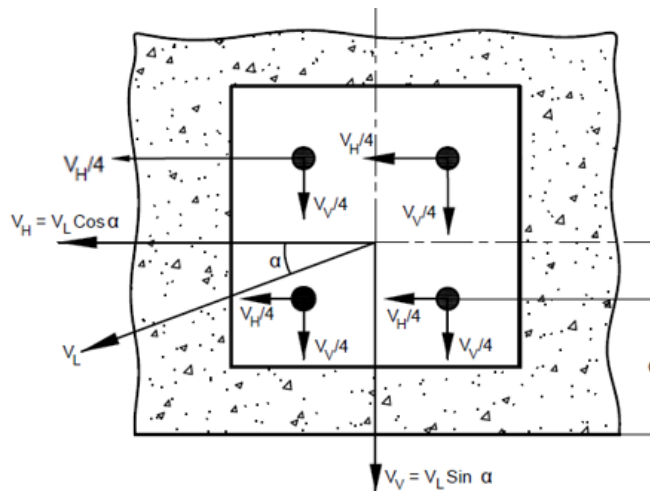

(36B) GROUP OF FOUR ANCHORS WHEN LOADED BY INCLINED SHEAR LOAD

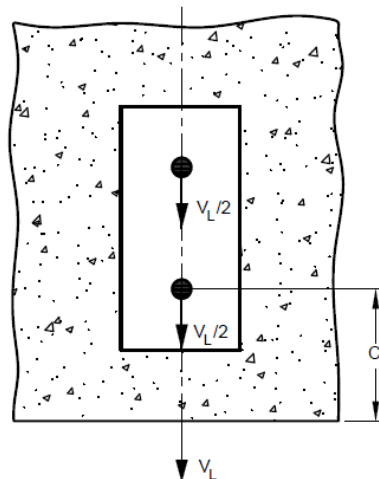

(36C) GROUP OF TWO ANCHORS WHEN LOADED IN SHEAR PERPENDICULAR TO THE EDGE

FIG. 36 DETERMINATION OF SHEAR LOADS FOR CASES WHEN LOAD IS TAKEN UP BY ALL ANCHORS (THAT IS, GAP BETWEEN THE ANCHOR AND THE BASE PLATE IS FILLED UP)

In special cases where the gap between the base plate and the anchor cannot be filled up or in case of seismic shear loading, the anchors located in most unfavorable position (that is anchors located closest to the edge) in case of concrete edge failure shall take up load. In case the shear load is acting parallel to the edge then all anchors shall be assumed to take up shear load. In case of concrete edge failure, if the anchor group is subjected to inclined shear, then the load components acting perpendicular to the edge shall be taken up by the most unfavorable anchors, while the load components acting parallel to the edge shall be equally distributed to all anchors of the group (see Fig. 37).

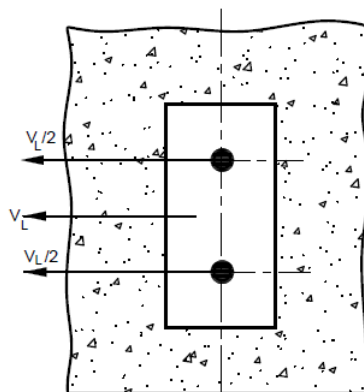

(37A) GROUP OF TWO ANCHORS WHEN LOADED IN SHEAR PARALLEL TO THE EDGE

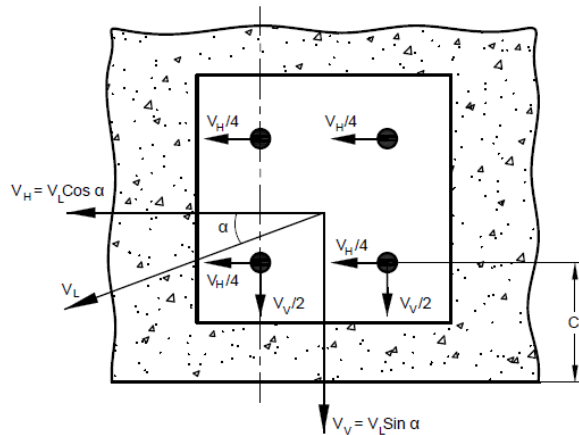

(37B) GROUP OF FOUR ANCHORS WHEN LOADED BY INCLINED SHEAR LOAD

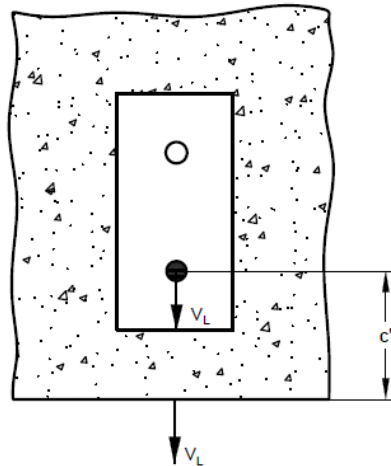

(37C) GROUP OF TWO ANCHORS WHEN LOADED IN SHEAR PERPENDICULAR TO THE EDGE

FIG. 37 DETERMINATION OF SHEAR LOADS FOR CASES WHEN LOAD IS TAKEN UP BY EDGE ANCHORS (THAT IS, GAP BETWEEN THE ANCHOR AND THE BASE PLATE IS NOT FILLED UP)

8.2.2.1 If the following conditions are met then it shall be assumed that anchors are subjected to shear loads without lever arm:

- The base plate is made of metal. In the area of the anchorage, the base plate is fixed directly to the concrete either without an intermediate layer or with a leveling layer of mortar with compression strength of at least 30 N/mm² and thickness $\leq d_a/2$.
- The base plate is in contact with the anchor over its entire thickness.

8.2.2.2 If the conditions given in **8.2.2.1** are not fulfilled then lever arm of shear load (l) shall be calculated according to the following equation (see Fig. 38).

$$l = a_3 + e_1$$

where,

$a_3 = 0.5d_a$ [exception: if a washer and a nut is directly clamped to the concrete surface (see Fig. 38B), then $a_3 = 0$]

e_1 = Distance between shear load and concrete surface (see Fig. 38A and 38B)

d_a = Anchor diameter; in case sleeve bears against the base plate use sleeve diameter (d_{nom}) (see Fig. 38A).

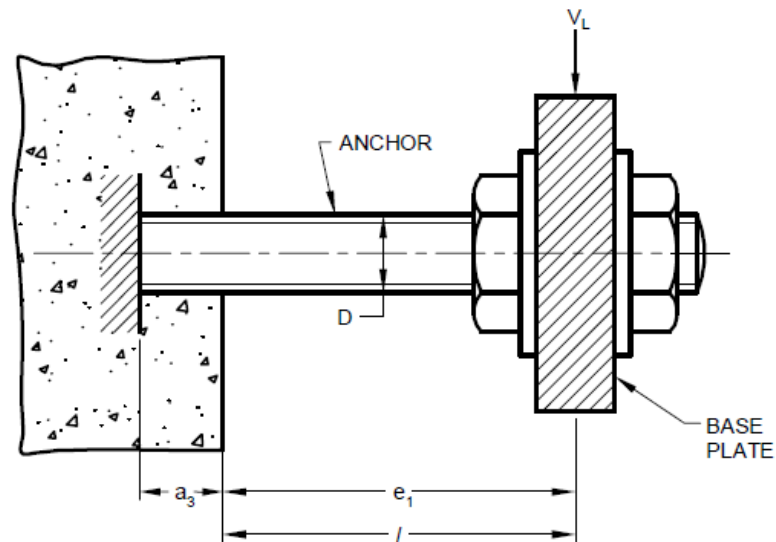

(38A) FOR ANCHORS DRILLED AND GROUTED

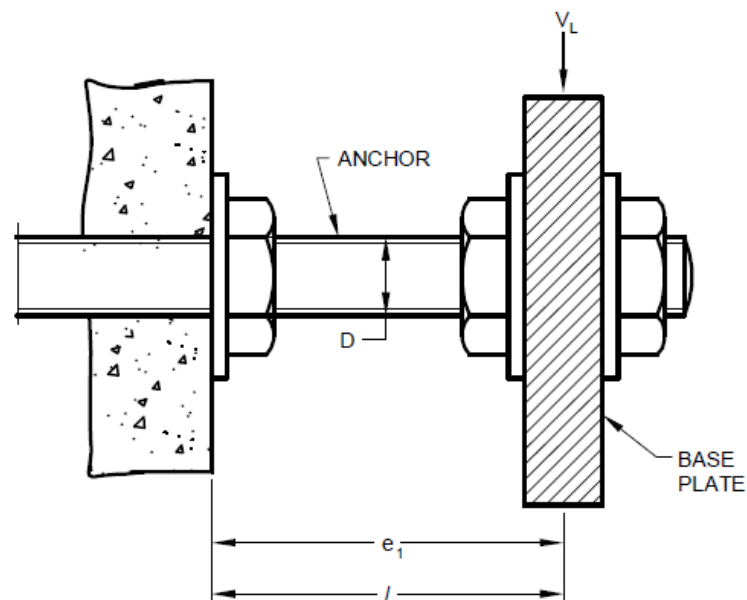

(38B) FOR ANCHORS BOLTED ON THE SURFACE

FIG. 38 DETERMINATION OF LEVER ARM

8.2.2.3 The design moment acting on the anchor due to shear load with lever arm shall be calculated according to the following equation:

$$M_{Ld} = V_{Ld}(l/\alpha_M)$$

The value of α_M depends on the degree of fixity of the anchor at the side of the base plate of the application in question. It shall be judged according to sound engineering practice.

- a) If the base plate can rotate freely (see Fig. 39A), then no fixity ($\alpha_M = 1.0$) shall be assumed.
- b) If the base plate is not free to rotate (see Fig. 39B), then full fixity ($\alpha_M = 2.0$) shall be assumed.

The base plate shall be able to take up the fixing moment in case restraint of the anchor is assumed.

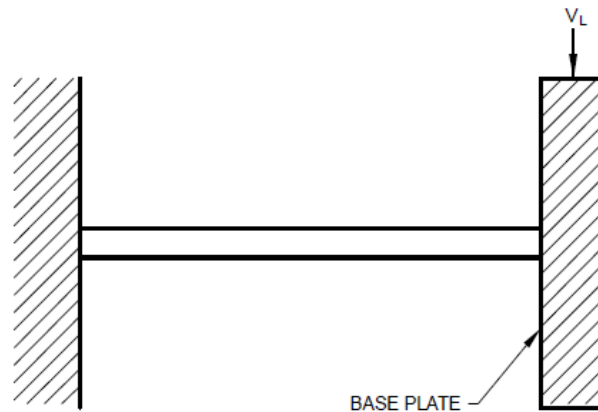

(39A) BASE PLATE WITHOUT ROTATIONAL RESTRAINT ($\alpha_M = 1.0$)

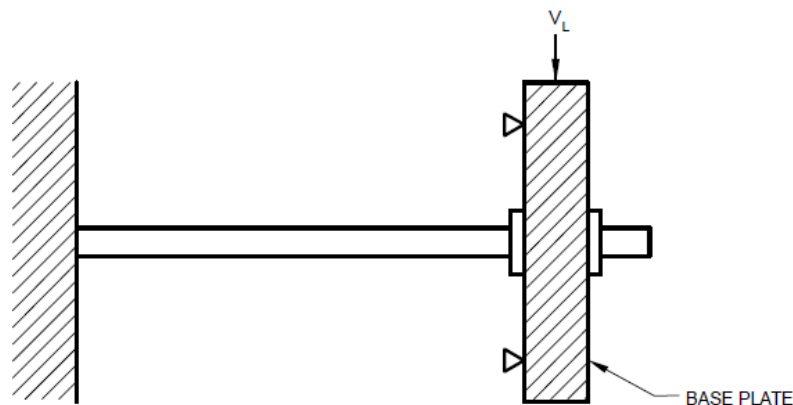

(39B) BASE PLATE WITH ROTATIONAL RESTRAINT ($\alpha_M = 2.0$)

FIG. 39 BASE PLATE RESTRAINT CONDITIONS

9 DESIGN OF POST-INSTALLED ANCHORING SYSTEMS FOR STATIC OR QUASI-STATIC CONDITIONS

9.1 General

The characteristic values of the anchor to be used for the calculation of anchor strength and parameters like spacing, edge distance, minimum thickness of concrete member, etc. shall be taken from the assessment report (AR) of the anchor.

9.1.1 Limit State Design

The design of anchorages shall be done using limit state design method. It shall be established that the value of the design load, L_d does not exceed the value of the design strength, R_d .

$$L_d \leq R_d$$

where,

$$L_d = \gamma_f L_e$$

L_e = Unfactored loads shall be obtained from IS 875 (all parts)

γ_f = Partial safety factor for loads (as per IS 456)

$$R_d = R_k / \gamma_M$$

R_k = Characteristic strength of a single anchor or an anchor group

γ_M = Partial safety factor for material.

9.1.2 Limit State of Strength

The limit state of strength are those associated with failures, under the action of most critical combination of loads on the anchorages using the appropriate partial safety factors, which may endanger the safety of life and property.

9.1.3 Limit State of Serviceability

In the serviceability limit state, it shall be ensured that the displacements of anchors occurring under the design loads are not larger than the admissible displacement as may be decided by the structural engineer.

NOTE — The admissible displacement depends on the application in question and shall be decided by the structural designer.

9.1.3.1 Displacements

The characteristic displacement of the anchor under defined tension and shear loads shall be taken from the Assessment Report. The displacements shall be assumed as a linear function of the applied load. In the case of combined tension and shear load, the displacements for the tension and the displacement for the shear component of the resultant load shall be geometrically added. The influence of the hole clearance in the base plate on the expected displacement of the whole anchorage system shall be taken into account in case of shear loads.

9.2 Design Method

The design strength shall be calculated according to limit state method of design for all load directions, namely tension, shear individually or combined as well as for all applicable failure modes. The minimum strength shall govern after verification of interaction of tension and shear forces for the load case.

9.2.1 Partial Safety Factors

a) Partial safety factor for concrete failure

These could be cone failure (γ_{Mc}), pull-out / pull-through failure (γ_{Mp}), concrete pry-out failure (γ_{Mc}), concrete edge failure (γ_{Mc}), splitting failure (γ_{Msp}) and bond failure (γ_{Mp}).

$$\gamma_{Mc} = \gamma_{Msp} = \gamma_{Mp} = \gamma_c \cdot \gamma_{inst}$$

γ_c = Partial safety factor for concrete (as per IS 456) = 1.5

γ_{inst} = Installation safety factor of an anchor system in tension shall be taken from AR of the anchor. Installation safety factor of an anchor system in shear shall be taken as 1.0.

b) Partial safety factor for Steel failure (γ_{Ms})

For tension loading: $\gamma_{Ms} = 1.2 / (f_y / f_u) \geq 1.4$

For shear loading of the anchor with and without lever arm:

$$\gamma_{Ms} = 1.0 / (f_y / f_u) \geq 1.25 \quad (\text{for } f_u \leq 800 \text{ N/mm}^2 \text{ and } f_y / f_u \leq 0.8)$$

$$\gamma_{Ms} = 1.5 \quad (\text{for } f_u > 800 \text{ N/mm}^2 \text{ or } f_y / f_u > 0.8)$$

9.2.2 Design Strength in Tension

The design strength in tension shall be calculated and checked according to limit state of design for all applicable failure modes as per Table 1, and the minimum strength shall govern.

Table 1 Design Strength Checks in Tension
(Clause 9.2.2)

SI No. (1)	Strength to Resist Expected Failure Types (2)	Checks for Single Anchor (3)	Checks for Anchor Group (4)
i)	Steel strength	$N_{Ld} \leq N_{Rk,s} / \gamma_{Ms}$	$N_{Ld,\sigma^*} \leq N_{Rk,s} / \gamma_{Ms}$
ii)	Concrete cone strength	$N_{Ld} \leq N_{Rk,c} / \gamma_{Mc}$	$N_{Ld,g} \leq N_{Rk,c} / \gamma_{Mc}$
iii)	Pull-out strength of mechanical anchor/ torque controlled adhesive anchor	$N_{Ld} \leq N_{Rk,p} / \gamma_{Mp}$	$N_{Ld,\sigma^*} \leq N_{Rk,p} / \gamma_{Mp}$
iv)	Pull-out strength of adhesive anchor	$N_{Ld} \leq N_{Rk,p} / \gamma_{Mp}$	$N_{Ld,g} \leq N_{Rk,p} / \gamma_{Mp}$
v)	Splitting strength	$N_{Ld} \leq N_{Rk,sp} / \gamma_{Msp}$	$N_{Ld,g} \leq N_{Rk,sp} / \gamma_{Msp}$

9.2.2.1 Determination of steel strength

The characteristic steel strength ($N_{Rk,s}$) of an anchor shall be taken from the AR of the anchor and the steel strength check in tension shall be performed according to Table 1.

NOTE – If the value of characteristic steel strength is not available in the AR or then it may be calculated using the following equation, $N_{Rk,s} = A_s f_u$

9.2.2.2 Determination of concrete cone strength

The characteristic concrete cone strength of an individual anchor or an anchor group, respectively, shall be determined according to the following equation:

$$N_{Rk,c} = N_{Rk,c}^0 (A_{c,N} / A_{c,N}^0) \Psi_{s,N} \Psi_{re,N} \Psi_{ec,N} \Psi_{M,N}$$

where

$N_{Rk,c}^0$ = The characteristic strength of a single anchor placed in cracked or uncracked concrete in tension not influenced by adjacent fasteners or edges of the concrete member

$$N_{Rk,c}^0 = 7.2 \sqrt{f_{ck}} h_{ef}^{1.5} \text{ (for applications in cracked concrete)}$$

$$N_{Rk,c}^0 = 10.1 \sqrt{f_{ck}} h_{ef}^{1.5} \text{ (for applications in uncracked concrete)}$$

NOTE – In case, higher performance is observed in the assessment report for the performance of an anchor for concrete cone strength, the same may be considered for design.

$$s'_{cr,N} = 3h_{ef} = 2c'_{cr,N}$$

$\Psi_{s,N}$ = Factor to account for discontinuities in the symmetric stress distribution in the concrete due to edges of the concrete member. The smallest edge distance shall be used as c' in the following equation.

$$\Psi_{s,N} = 0.7 + 0.3(c' / c'_{cr,N}) \leq 1.0$$

$\Psi_{re,N}$ = Factor to account for the effect of dense reinforcement between which the fastener is installed.

$$\Psi_{re,N} = 0.5 + (h_{ef} / 200) \leq 1.0$$

NOTE – If in the area of the anchorage there is reinforcement with a spacing ≥ 150 mm (any diameter) or with a diameter ≤ 10 mm and a spacing ≥ 100 mm then the factor $\Psi_{re,N}$ shall be taken as 1.0.

$\Psi_{ec,N}$ = Factor to account for group effect when different tension loads are acting on the individual anchors of an anchor group. Where there is an eccentricity in two directions, $\Psi_{ec,N}$ shall be determined separately for each direction and the product of both factors shall be inserted the above equation for determining $N_{Rk,c}$.

$$\Psi_{ec,N} = \frac{1}{[1 + (2e_N / s'_{cr,N})]} \leq 1$$

$A_{c,N}^0$ = Idealized projected concrete cone area of an individual anchor with no influence of edge and spacing on the concrete cone strength of the anchor. It shall be calculated by idealizing the concrete cone as a pyramid with a height equal to h_{ef} and a base length equal to $s'_{cr,N}$ (see Fig. 40), $A_{c,N}^0 = s'_{cr,N} \cdot s'_{cr,N}$

$A_{c,N}$ = Actual projected concrete cone area of the anchorage at the concrete surface. It is limited by overlapping concrete cones of adjoining anchors as well as by edges of the concrete member when edge and spacing are less than the critical values (see Fig. 41).

$\Psi_{M,N}$ = Factor to account for the influence of a compression force between the base plate and the concrete on the tensile strength of the anchor. The value shall be considered as 1 if either of the following criteria are met:

- a) The anchor is located close to the edge $c' < 1.5 h_{ef}$
- b) Anchors which are located away from the edge ($c' > 1.5 h_{ef}$) and loaded by bending moment as well as tension force, satisfy the equation $\frac{N_c''}{N_{Ld}} < 0.8$
- c) $\frac{z}{h_{ef}} > 1.5$

For all other applications, it should be taken as $\left(2 - \frac{z}{h_{ef}}\right) \geq 1$

(z = lever arm and N_c'' is the resultant compression force between the base plate and the concrete)

For direct tension forces the factor $\Psi_{M,N}$ shall be considered as 1.

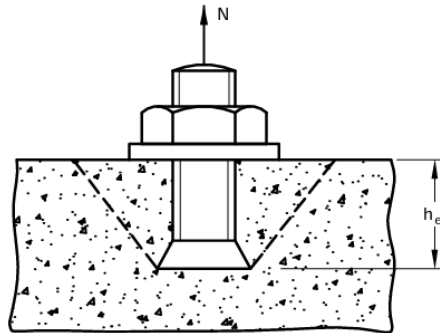

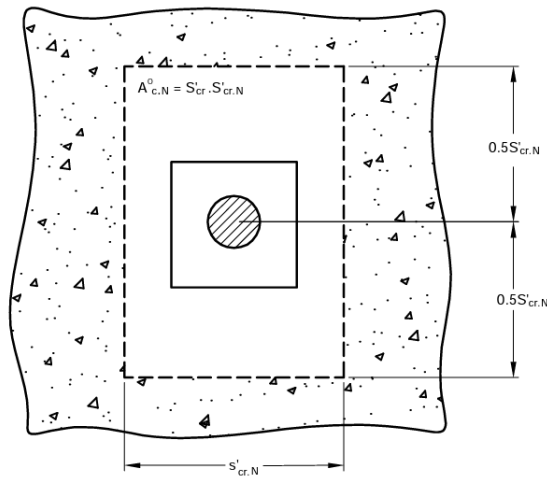
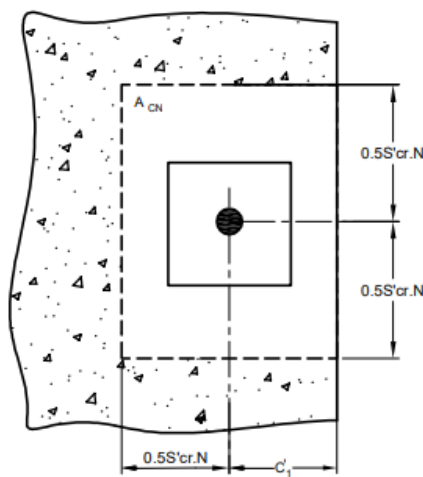

FIG. 40 IDEALIZED PROJECTED CONE AREA OF AN INDIVIDUAL ANCHOR



$$A_{c,N} = (c'_1 + 0.5s'_{cr,N}) * s'_{cr,N}$$

where

$$c'_1 \leq c'_{cr,N}$$

(41A) INDIVIDUAL ANCHOR LOCATED CLOSE TO THE EDGE OF CONCRETE MEMBER

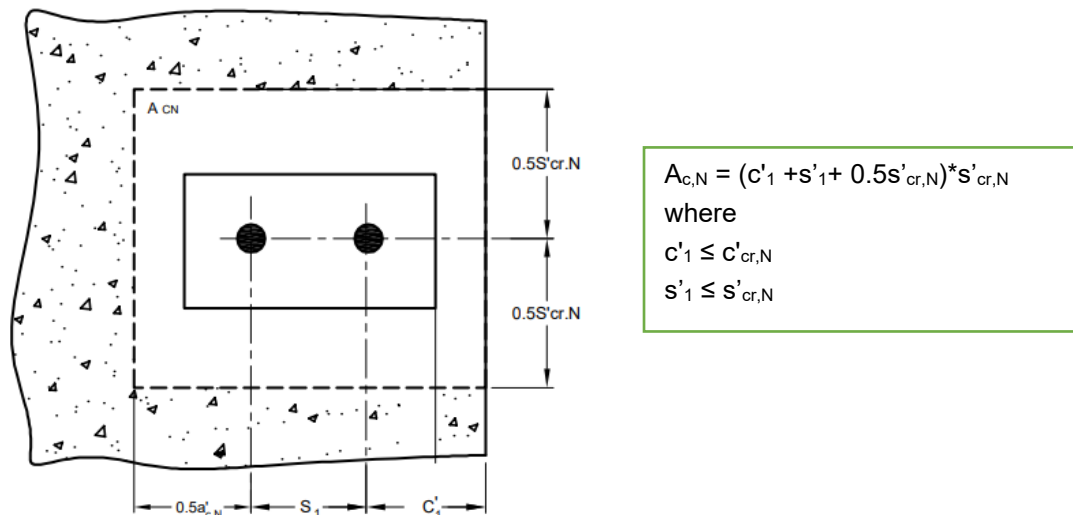

(41B) GROUP OF TWO ANCHORS LOCATED CLOSE TO THE EDGE OF CONCRETE MEMBER

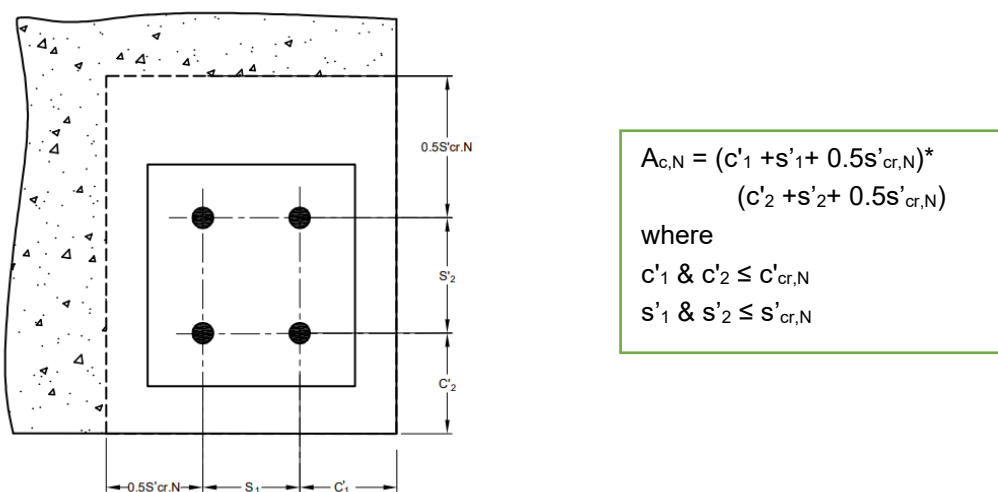

(41C) GROUP OF FOUR ANCHORS LOCATED AT A CORNER OF CONCRETE MEMBER

FIG. 41 EXAMPLES OF ACTUAL PROJECTED CONCRETE CONE AREA FOR DIFFERENT ANCHOR CONFIGURATIONS

9.2.2.2.1 Special case

For anchorages with three or more edges with the largest edge distance less than the critical edge distance for concrete cone in tension (see Fig. 42), the calculation of strength as above may lead to very conservative values. For such cases, the embedment depth, h_{ef} , spacing, $s'_{cr,N}$ and edge distance, $c'_{cr,N}$ shall be substituted with their modified values as indicated below for determining the characteristic concrete cone strength, $N_{Rk,C}$ according to 9.2.2.2. However, $\Psi_{re,N}$ shall be calculated with h_{ef} only.

$$h_{ef,mod} = \max\left[\left(c'_{max}/c'_{cr,N}\right)h_{ef}, \left(s'_{max}/s'_{cr,N}\right)h_{ef}\right]$$

$$s'_{cr,N,mod} = \left(h_{ef,mod}/h_{ef}\right)s'_{cr,N}$$

$$c'_{cr,N,mod} = \left(h_{ef,mod}/h_{ef}\right)c'_{cr,N}$$

where c'_{max} is the maximum distance from the center of the anchor to the edge of concrete member ($< c'_{cr,N}$), and

s'_{max} is the maximum center to center distance between anchors ($< s'_{cr,N}$)

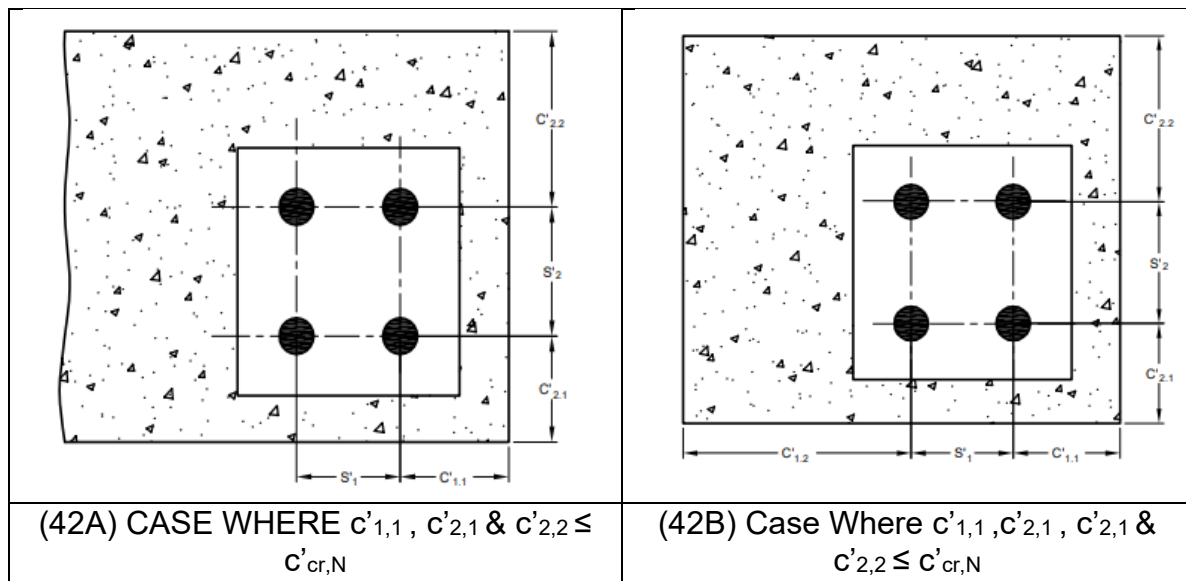

FIG. 42 EXAMPLES OF SPECIAL CASES

9.2.2.3 Pull-out strength of mechanical anchors

The characteristic pull-out strength shall be taken from the AR of the anchor, depending on the concrete strength and the state of concrete (cracked or uncracked) assumed for design. The pullout strength shall be checked for anchor that is most stressed due to load.

9.2.2.4 Pull-out (bond) strength of adhesive anchors

The characteristic pull-out strength of an individual anchor or an anchor group, shall be determined according to the following equation:

$$N_{RK,p} = N_{RK,p}^0 \left(A_{p,N} / A_{p,N}^0 \right) \Psi_{s,Np} \Psi_{re,Np} \Psi_{ec,Np} \Psi_{g,Np}$$

where,

$N_{RK,p}^0$ = The characteristic pull-out strength of an adhesive anchor placed in cracked or uncracked concrete and not influenced by adjacent fasteners or edges of the concrete member.

$$N_{RK,p}^0 = \Psi_{sus} \pi d_a h_{ef} \tau_{RK,cr'} \quad (\text{for applications in cracked concrete})$$

$$N_{RK,p}^0 = \Psi_{sus} \pi d_a h_{ef} \tau_{RK,uncr'} \quad (\text{for applications in uncracked concrete})$$

The values of $\tau_{Rk,cr'}$ & $\tau_{Rk,uncr'}$ are to be taken from AR.

$$\Psi_{sus} = 1 \text{ for } a_{sus} \leq \Psi_{sus}^0$$

$$\Psi_{sus} = \Psi_{sus}^0 + 1 - a_{sus} \text{ for } a_{sus} > \Psi_{sus}^0$$

where

Ψ_{sus}^0 is the product depending factor accounting for the effect of sustained loading on the bond strength of adhesive anchor. It shall be taken from the AR of the adhesive anchor, and it shall be taken as 0.6 if no value is given.

a_{sus} is the ratio between the value of sustained action (permanent action+permanent component of variable action) and the value of total action considered at limit state

$s'_{cr,Np}$ = Critical spacing for pull-out. In the following equation, $\tau_{Rk,uncr'}$ shall correspond to M25 grade concrete,

$$= 7.3d_a(\Psi_{sus}\tau_{Rk,uncr'})^{0.5} \leq 3h_{ef}$$

$c'_{cr,Np}$ = critical edge distance for pull-out

$$= 0.5s'_{cr,Np}$$

$\Psi_{s,Np}$ = Factor to account for discontinuities in the symmetrical stress distribution in the concrete due to edges of the concrete member.

$$= 0.7 + 0.3(c'/c'_{cr,Np}) \leq 1.0$$

$\Psi_{re,Np}$ = Factor to account for the negative effect of orthogonal reinforcement (that is, with orientation perpendicular to the direction of the force) in the area of the concrete cone

$$= 0.5 + (h_{ef}/200) \leq 1.0$$

NOTE – If in the area of the anchorage there is reinforcement with a spacing ≥ 150 mm (any diameter) or with a diameter ≤ 10 mm and a spacing ≥ 100 mm then the factor $\Psi_{re,Np}$ shall be taken as 1.0.

$\Psi_{ec,Np}$ = Factor to account for group effect when different tension loads are acting on the individual anchors of an anchor group

$$= \frac{1}{[1+(2e_N/s'_{cr,Np})]} \leq 1$$

$\Psi_{g,Np}$ = Factor to account for the effect of failure surface for the anchor group. For individual anchor, this factor shall be taken as 1.0. The characteristic bond value τ_{Rk} shall correspond to the strength and the state of concrete assumed for design (cracked or uncracked)

$$= \Psi_{g,Np}^0 - (s'/s'_{cr,Np})^{0.5}(\Psi_{g,Np}^0 - 1) \geq 1.0$$

$$\Psi_{g,Np}^0 = \sqrt{n} - (\sqrt{n} - 1) \left[\frac{d_a \tau_{Rk}}{\varphi \sqrt{h_{ef}} \sqrt{f_{ck}}} \right]^{1.5} \geq 1.0$$

n = No. of anchors in a group

$$\varphi = 2.3 \text{ for cracked concrete}$$

= 3.2 for uncracked concrete

$A_{c,Np}^0$ = Idealized projected concrete cone area of an individual anchor with no influence of edge and spacing on the pull-out strength of the anchor. It shall be calculated by idealizing the concrete cone as a pyramid with a height equal to h_{ef} and a base length equal to $s'_{cr,Np}$ (see Fig. 40)

$$A_{c,Np}^0 = s'_{cr,Np} \cdot s'_{cr,Np}$$

$A_{c,Np}$ = Actual projected concrete cone area of the anchorage at the concrete surface. It is limited by overlapping concrete cones of adjoining anchors as well as by edges of the concrete member when edge and spacing are less than the critical values. $A_{c,Np}$ shall be calculated in a manner similar to $A_{c,N}$ as shown in Fig. 41 but using the critical edge distance ($c'_{cr,Np}$) and spacing ($s'_{cr,Np}$) values that correspond to pull-out

9.2.2.5 Special case

For anchorages with three or more edges with the largest edge distance less than the critical edge distance for pullout in tension, the calculation of strength as above may lead to very conservative values. For such cases, the embedment depth, h_{ef} , spacing, $s'_{cr,N}$ and edge distance, $c'_{cr,N}$ shall be substituted with their modified values as indicated below for determining the characteristic pull out strength $N_{Rk,p}$ according to

However, $\Psi_{re,N}$ shall be calculated with h_{ef} only.

$$h_{ef,mod} = \max[(c'_{max}/c'_{cr,Np})h_{ef}, (s'_{max}/s_{cr,Np})h_{ef}]$$

$$s'_{cr,Np,mod} = (h_{ef,mod}/h_{ef})s'_{cr,Np}$$

$$c'_{cr,Np,mod} = (h_{ef,mod}/h_{ef})c'_{cr,Np}$$

9.2.2.6 Determination of splitting strength

The characteristic splitting strength of an individual anchor or an anchor group, shall be determined using the following equation:

$$N_{Rk,sp} = N_{Rk,sp}^0 (A_{c,N}/A_{c,N}^0) \Psi_{s,N} \Psi_{re,N} \Psi_{ec,N} \Psi_{h,sp}$$

where $N_{Rk,sp}^0$ shall be taken as minimum of $N_{Rk,c}$ and $N_{Rk,p}$.

The factors $N_{Rk,c}$, $A_{c,N}$, $A_{c,N}^0$, $\Psi_{s,N}$, $\Psi_{ec,N}$, $\Psi_{re,N}$ shall be determined according to 9.2.2.2 but using the critical edge distance ($c'_{cr,sp}$) and spacing ($s'_{cr,sp}$) values that correspond to splitting, taken from the AR of the anchor.

$\Psi_{h,sp}$ = Factor to account for the influence of the actual base material depth (D) on the splitting strength. In the following equation, D_{min} corresponding to splitting failure shall be used.

$$\Psi_{h,sp} = (D/D_{min})^{\frac{2}{3}} \leq \max[1, (h_{ef} + 1.5 c' / D_{min})^{\frac{2}{3}}] \leq 2$$

NOTE – This check may be omitted if either of the following conditions are fulfilled:

- a) The edge distance in all directions is greater than or equal to $1.2c'_{cr,sp}$ and the base material is greater than or equal to $2h_{ef}$.
- b) For anchors suitable for use in cracked concrete:
 - 1) Reinforcement is present to limit crack width to 0.3 mm, taking into account the splitting forces according to section 9.3
 - 2) The characteristic strength for concrete cone failure and pull-out failure is calculated for cracked concrete
- c) If the edge distance of an anchor is smaller than the value $c_{cr,sp}$ then the presence of longitudinal reinforcement between anchor and edge should be ensured.

9.2.2.7 Special case

The special case for anchorages with three or more edges as defined under 9.2.2.2 shall also apply to splitting failure due to loading. The modified value of embedment, spacing and edge distance as recommended under 9.2.2.2 shall be calculated using critical edge and spacing values corresponding to splitting failure. However, the range for $\Psi_{h,sp}$ for adhesive anchors shall be calculated using the actual value embedment, h_{ef} .

9.2.3 Design Strength in Shear

The design strength in shear shall be calculated and checked according to limit state of design for all applicable failure modes as per Table 2. The minimum strength shall govern.

Table 2 Design Strength Checks in Shear

(Clause 7.2.3)

SI No. (1)	Strength to Resist Expected Failure Types (2)	Checks for Single Anchor (3)	Checks for Anchor Group (4)
i)	Steel strength (for shear load without lever arm)	$V_{Ld} \leq V_{Rk,s}/\gamma_{Ms}$	$V_{Ld,\sigma^*} \leq V_{Rk,s}/\gamma_{Ms}$
ii)	Steel strength (for shear load with lever arm)	$V_{Ld} \leq V_{Rk,s}/\gamma_{Ms}$	$V_{Ld,\sigma^*} \leq V_{Rk,s}/\gamma_{Ms}$
iii)	Concrete pry-out strength	$V_{Ld} \leq V_{Rk,cp}/\gamma_{Mc}$	$V_{Ld,g} \leq V_{Rk,cp}/\gamma_{Mc}$
iv)	Concrete edge strength	$V_{Ld} \leq V_{Rk,c}/\gamma_{Mc}$	$V_{Ld,g} \leq V_{Rk,c}/\gamma_{Mc}$

9.2.3.1 steel strength for shear load without lever arm

The characteristic steel strength, $V_{Rk,s}^0$ of an anchor subjected to shear load without lever arm shall be taken from the AR of the anchor.

The characteristic resistance of a fastener ($V_{Rk,s}$) accounting for ductility of the fastener in a group is given by

$$V_{Rk,s} = k_1 V_{Rk,s}^0$$

k_1 is product dependent factor and shall be taken from the AR.

NOTE – If the value of characteristic steel strength is not available in the AR then it may be calculated using the following equation for anchors having uniform cross section along its length.

$$V_{Rk,s}^0 = 0.5A_s f_u \quad [\text{This is applicable only for } f_u \leq 1\,000 \text{ N/mm}^2]$$

9.2.3.2 steel strength for shear load with lever arm

The characteristic steel strength, $V_{Rk,s}$ of an anchor subjected to shear load with lever arm shall be calculated using the following equation. The characteristic bending strength $M_{Rk,s}^0$, characteristic steel strength $N_{Rk,s}$ and the material safety factor γ_{Ms} shall be taken from AR of the anchor.

$$V_{Rk,s} = (\alpha_M M_{Rk,s}) / l$$

where,

α_M = Factor to account for degree of fixity of the anchor at the side of the base plate (see 8.2.2.3)

l = Lever arm (see 8.2.2.2)

$$M_{Rk,s} = M_{Rk,s}^0 [1 - N_{Ld} / (N_{Rk,s} / \gamma_{Ms})]$$

NOTE – If the value of characteristic bending strength is not available in the AR then it may be calculated using the following equation for anchors having uniform cross section along its length.

$$M_{Rk,s}^0 = 1.2Z_{el} f_u$$

9.2.3.3 Determination of concrete pry-out strength

The characteristic concrete pry-out strength (see Fig. 43) of an individual anchor or an anchor group, shall be determined according to the following equations.

For mechanical anchors, $V_{Rk,cp} = k_{cp} N_{Rk,c}$

For adhesive anchors: $V_{Rk,cp} = \min(k_{cp} N_{Rk,p}, k_{cp} N_{Rk,c})$

The factor k_{cp} shall be taken from the relevant assessment report.

NOTE – In cases where the anchor group is loaded by shear loads and/or external torsion moments, the direction of the individual shear loads may change. Fig 44 demonstrates this for a group of two anchors loaded by a torsion moment. The above equations are not suitable for this application. The shear loads acting on the individual anchors neutralize each other and the shear load acting on the entire group (V_{Ld}) is 0.

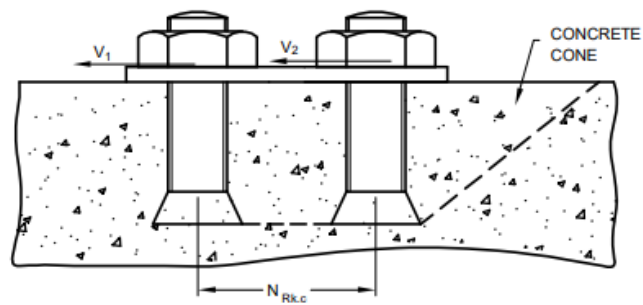

FIG. 431 TYPICAL CONCRETE PRY-OUT FAILURE

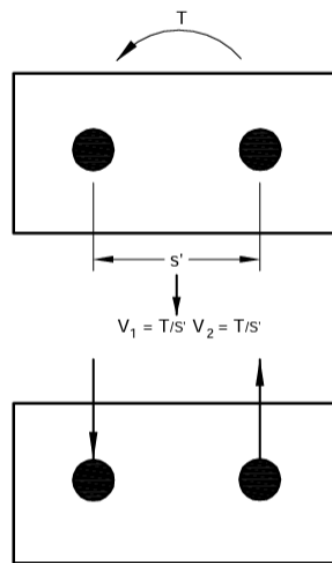
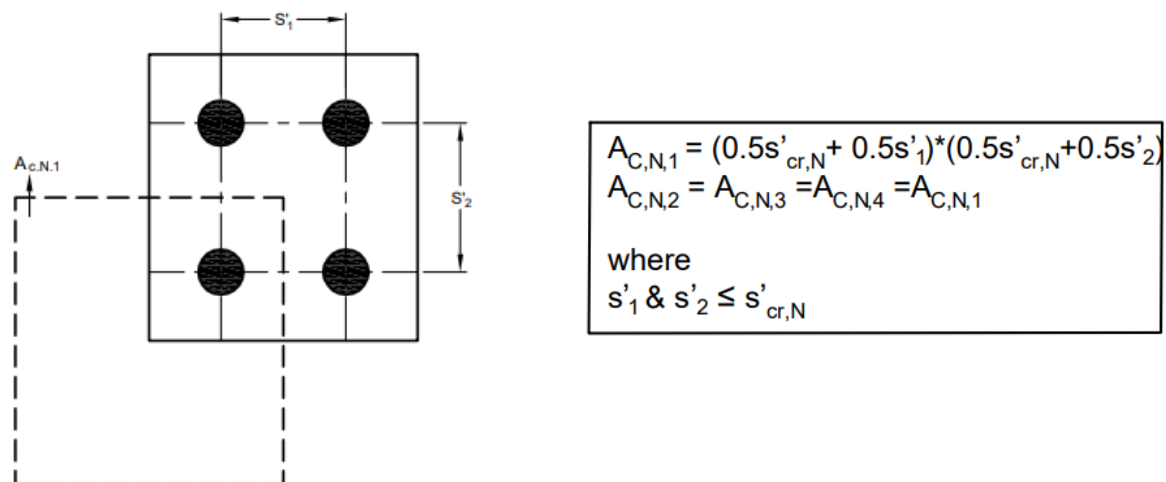
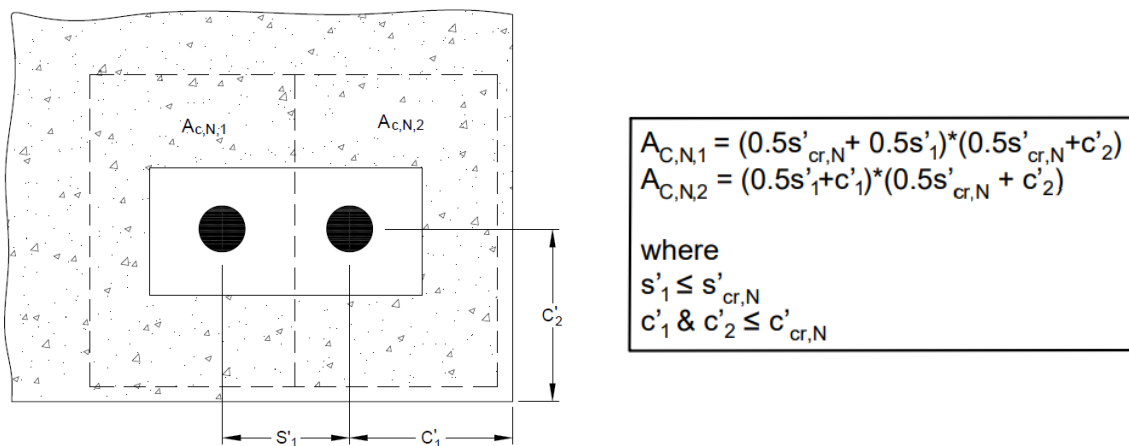

FIG.44 GROUP OF ANCHORS LOADED BY TORSION MOMENT

When the horizontal or vertical components of the shear loads on the anchors change direction within a group (for example, torsion or inclined shear), the verification of pry-out failure for the entire group shall be substituted by the verification of pry-out failure for the most unfavorably positioned and loaded anchor of the group. When calculating the strength of the most unfavorable anchor, the influences of both edge distances as well as anchor spacing shall be considered. This shall be done by using the $A_{c,N}$ for the most unfavorably loaded anchor in N_{Rk} calculation for determining concrete pryout strength using above equation. Examples for the calculation of $A_{c,N}$ for individual anchors of an anchor group are illustrated in Fig. 45.



(45A) GROUP OF FOUR ANCHORS WITHOUT EDGE INFLUENCE



(45B) GROUP OF TWO ANCHORS IN A CORNER

FIG. 45 EXAMPLES OF ACTUAL PROJECTED CONCRETE CONE AREA ($A_{C,N}$) FOR INDIVIDUAL ANCHORS IN A GROUP

9.2.3.4 Concrete edge strength

The characteristic concrete edge strength of an individual anchor or an anchor group, shall be determined according to the following equation. For anchorages placed at a corner, the strengths for both edges shall be calculated, and the smallest value shall govern.

$$V_{Rk,c} = V_{Rk,c}^0 (A_{c,V} / A_{c,V}^0) \Psi_{s,V} \Psi_{re,V} \Psi_{ec,V} \Psi_{h,V} \Psi_{\alpha,V}$$

In case of an anchor group with filled clearance holes and more than one row in direction of the shear load each crack plane shall be considered separately. The verification shall be made for each crack plane.

This has been elaborated in Fig 48.

The resolution of shear force within an anchor group and the corresponding verification for the crack plane has been illustrated in Annex B.

In case the hole filling cannot be conformed at site, only the capacity of the front row anchors shall be considered for concrete edge break-out verification.

$V_{Rk,c}^0$ = The characteristic strength of a single anchor placed in cracked or uncracked concrete, loaded perpendicular to the edge in shear and not influenced by adjacent fasteners or edges of the concrete member

$$= 1.7d^\alpha h_{ef}^\beta \sqrt{f_{ck}} c'_1{}^{1.5} \text{ (for applications in cracked concrete)}$$

$$= 2.4d_a^\alpha h_{ef}^\beta \sqrt{f_{ck}} c'_1{}^{1.5} \text{ (for applications in uncracked concrete)}$$

$$\alpha = 0.1(h_{ef}/c'_1)^{0.5}$$

$$\beta = 0.1(d_a/c'_1)^{0.2}$$

$$s'_{cr,V} = 3c'_1 = 2c'_{cr,V}$$

$\Psi_{s,V}$ = Factor to account for discontinuities in the symmetrical stress distribution in the concrete due to edges of the concrete member on shear strength.

For anchorages with the edges parallel to the direction of load (for example in a narrow concrete member), the smallest edge distance shall be used as c'_2 in the following equation.

$$\Psi_{s,V} = 0.7 + 0.3(c'_2/1.5c'_1) \leq 1.0$$

$\Psi_{re,V}$ = Factor to account for effect of reinforcement in cracked concrete.

= 1.0 (For anchorage in uncracked concrete and anchorage in cracked concrete without edge reinforcement)

= 1.4 (For anchorage in cracked concrete with edge reinforcement and closely spaced stirrups (spaced at less than or equal to 100 mm))

$\Psi_{ec,V}$ = Factor to account for group effect when different shear loads are acting on the individual anchors of an anchor group.

$$= \frac{1}{[1+(2e_V/s'_{cr,V})]} \leq 1$$

$\Psi_{h,V}$ = Factor to account for member thickness

$$= (1.5c'_1/D)^{0.5} \geq 1$$

$\Psi_{\alpha,V}$ = Factor to account for the angle α_V between the load applied, V_{Ld} , and the direction perpendicular to the free edge of the concrete member ($\alpha_V \leq 90^\circ$).

$$= \sqrt{\frac{1}{(\cos \alpha_V)^2 + (0.5 \sin \alpha_V)^2}} \geq 1.0$$

NOTE – In case $\alpha_v > 90^\circ$ it shall be assumed that only the component of the shear load parallel to the edge is acting on the anchor. The component acting away from the edge may be neglected for checking concrete edge failure.

$A_{c,v}^0$ = Idealized projected concrete cone area of an individual anchor at the lateral concrete surface with no influence of edge, spacing and member thickness on the concrete edge strength of the anchor. It shall be calculated by idealizing the concrete edge cone as half pyramid with height equal to $1.5c_1$ and a base length equal to $3c'_1$ (see Fig. 46).

$$A_{c,N}^0 = 4.5c_1'^2$$

$A_{c,v}$ = Actual projected concrete cone area of the anchorage at the lateral concrete surface. It is limited by overlapping concrete cones of adjoining anchors, member thickness as well as by edges of the concrete member parallel to the assumed load direction (see Fig. 47).

NOTE – For the calculation of $A_{c,N}^0$ and $A_{c,v}$ it is assumed that the shear loads are applied perpendicular to the edge of the concrete member.

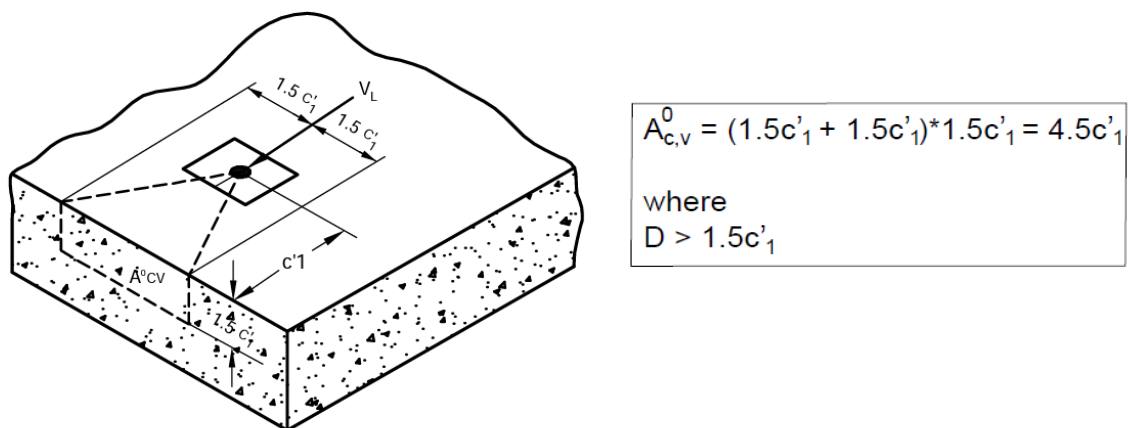
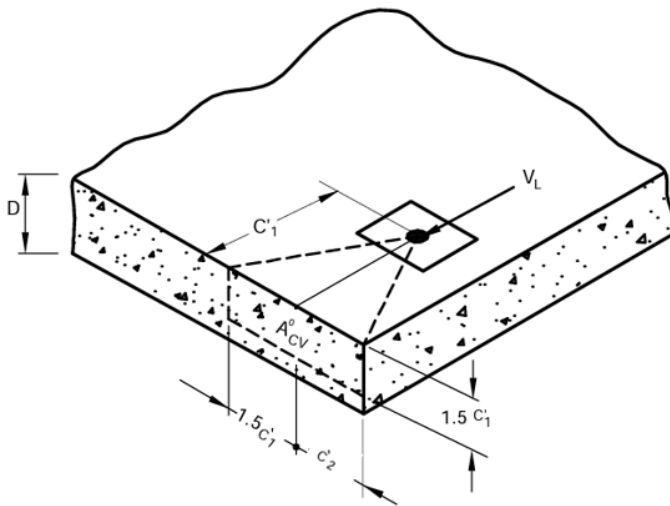

FIG. 46 IDEALIZED PROJECTED CONCRETE CONE AREA, $A_{c,v}^0$ OF AN INDIVIDUAL ANCHOR



$$A_{c,v} = (1.5c'_1 + c'_2) * 1.5c'_1$$

where

$$D > 1.5c'_1$$

$$c'_2 \leq 1.5c'_1$$

(47A) SINGLE ANCHOR AT A CORNER

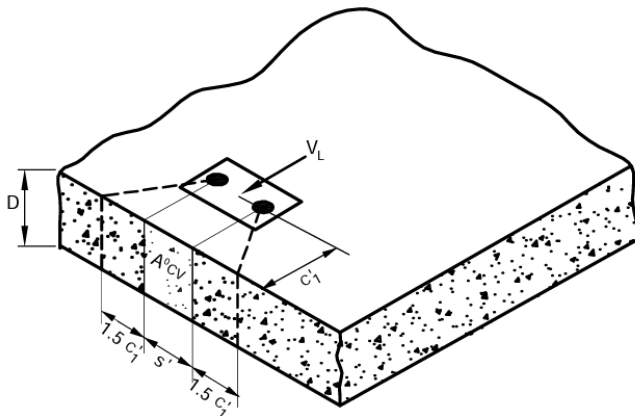

$$A_{c,v} = (1.5c'_1 + s'_2 + 1.5c'_1) * D$$

where

$$D \leq 1.5c'_1$$

$$s'_2 \leq 3c'_1$$

(47B) GROUP OF ANCHORS AT AN EDGE IN A THIN CONCRETE MEMBER

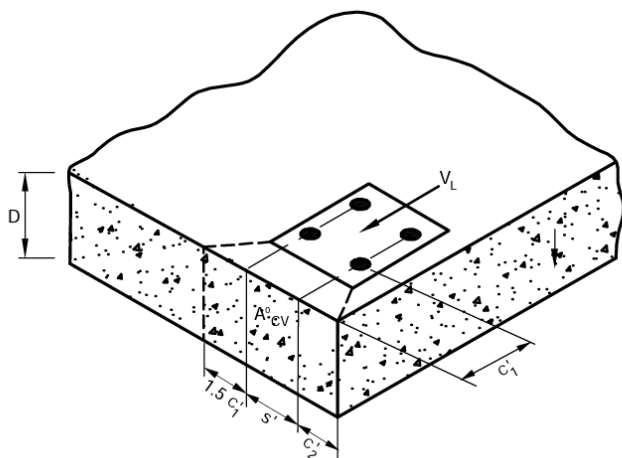

$$A_{c,v} = (1.5c'_1 + s'_2 + c'_2) * D$$

where

$$D \leq 1.5c'_1$$

$$s'_2 \leq 3c'_1$$

$$c'_2 \leq 1.5c'_1$$

(47C) GROUP OF ANCHORS AT CORNER IN A THIN CONCRETE MEMBER with unfilled clearance holes (front anchor take the shear load perpendicular to the edge)

FIG. 47 EXAMPLES OF ACTUAL PROJECTED CONCRETE CONE AREA FOR DIFFERENT ANCHOR CONFIGURATIONS SUBJECTED TO SHEAR LOAD

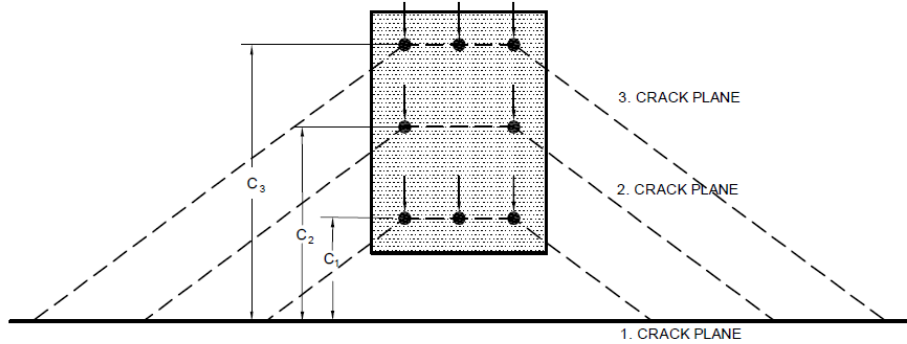

FIG. 48 CRACK PLANES WITH A GROUP OF 8 ANCHORS WITH A SHEAR LOAD PERPENDICULAR TO THE EDGE WITHIN THE RESPECTIVE CRACK PLANE FOR FILLED HOLES

		<p>Loads directed away from the edge, hence no proof for concrete edge failure needed.</p>
<p>(49A) GROUP OF ANCHORS AT AN EDGE LOADED BY V_{ld} With An Angle $\alpha_v = 180^\circ$</p>		
<p>Total Load Action</p>		
<p>Load on each anchor</p>		<p>Load components directed away from the edge are neglected</p>

<p>Load on anchor group for calculations</p>		
<p>(49B) GROUP OF ANCHORS AT AN EDGE LOADED BY v_{ld} With An Angle $90^\circ < \alpha_v < 180^\circ$</p>		
<p>Total load Action</p>		
<p>Load on each anchor</p>		<p>Load components directed away from the edge are neglected</p>
<p>Load on anchor group for calculations</p>		
<p>(49C) GROUP OF ANCHORS AT THE EDGE LOADED BY A TORSION MOMENT</p>		

FIG. 49 EXAMPLES OF ANCHOR GROUP AT EDGE LOADED BY SHEAR FORCE OR TORSION

<p>Action</p>		
<p>Load on each anchor</p>	 <p>Loads neglected because sum of components is directed away from the edge</p>	

Load on anchor group		
Load on anchor group for calculations		
Action		
Load on each anchor		
Load on anchor group		
Load on anchor group for calculations		

FIG. 50 EXAMPLES OF ANCHOR GROUP AT EDGE LOADED BY SHEAR FORCE AND TORSION

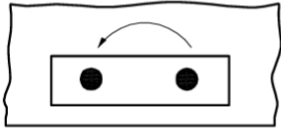
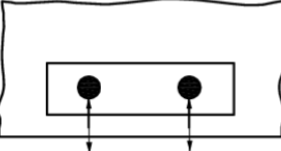
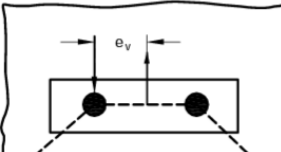
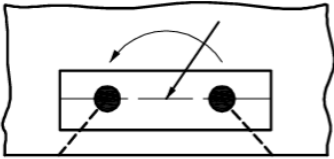
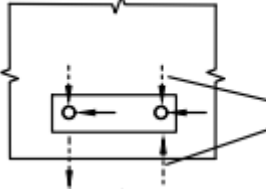
9.2.3.4.1 Special Case

For anchorages in a narrow or thin member ($D < 1.5c'_1$) with the largest edge distance less than the critical edge distance of $1.5c'_1$ in shear, the calculation of strength according to 9.2.3.4 may lead to very conservative values. For such cases, the edge distance c_1 shall be substituted with modified value c'_1 as indicated below in all equations in 9.2.3.4.

For single anchor

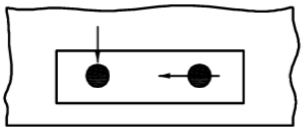
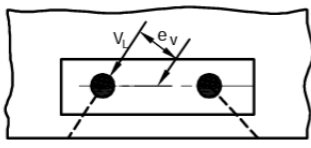
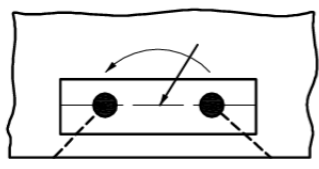
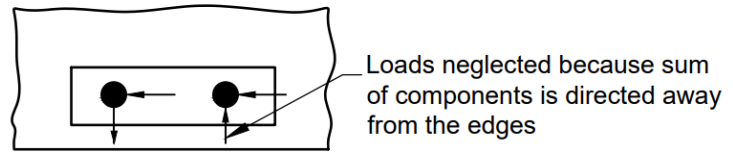
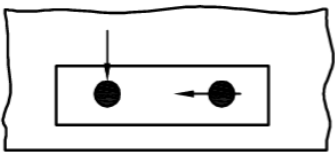
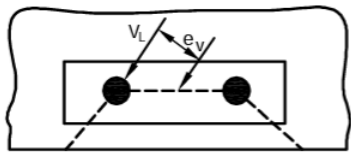
$$c'_1 = \max(c'_{2\max}/1.5, D/1.5)$$

For group of anchors,

$$c'_1 = \max(c'_{2\max}/1.5, D/1.5, s'_{2\max}/3)$$

Where $s'_{2\max}$ is the maximum spacing between the anchors in the orthogonal directions

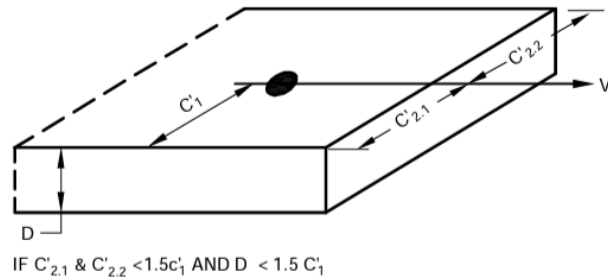

FIG. 51 EXAMPLES OF ANCHORAGE IN A THIN NARROW MEMBER

9.2.4 Check for Combined Tension and Shear

The following equations shall be satisfied for combined tension and shear loads (see Fig. 52).

$$\beta_N \leq 1$$

$$\beta_V \leq 1$$

$$(\beta_N) + (\beta_V) \leq 1.2 \quad (\text{for failure mode other than steel})$$

Or

$$(\beta_N)^\alpha + (\beta_V)^\alpha \leq 1$$

where,

$\alpha = 2.0$, if N_{Ld} and V_{Rd} are governed by steel failure, and

$\alpha = 1.5$, for all other failure modes

β_N and β_V = Ratio between design load and design strength for tension and shear loading, respectively. The largest value of β_N and β_V for the different failure modes shall be taken.

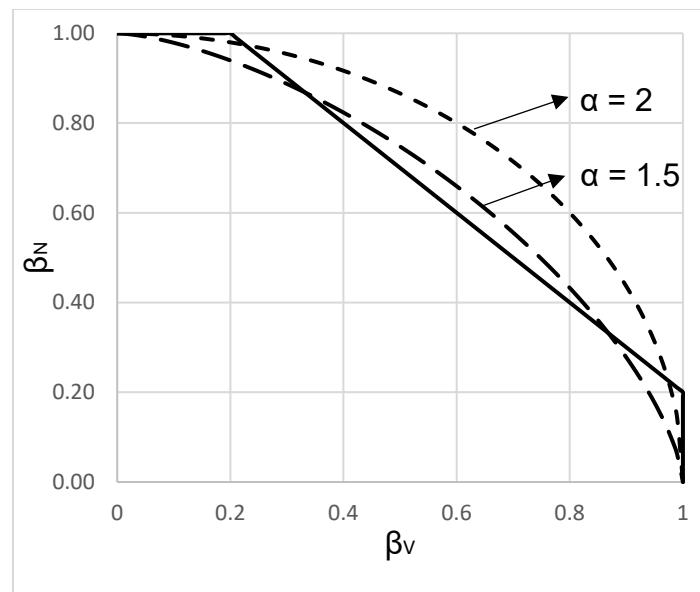

FIG. 52 INTERACTION DIAGRAM FOR COMBINED TENSION AND SHEAR LOADS

10 DESIGN OF POST-INSTALLED ANCHORING SYSTEMS FOR EARTHQUAKE EFFECTS

10.1 General

The basic design requirement and provisions for static conditions shall also apply to design of anchor for seismic conditions. The partial safety factors recommended for static conditions are applicable for seismic design as well. In addition, the requirements of this section shall be fulfilled.

10.1.1 Anchors

As a prerequisite for seismic design, the anchors shall be tested and evaluated as per seismic test provisions in addition to cracked assessment requirements. Appropriate measures shall be adopted to avoid loosening of nut during seismic event (for example, double nut). Further, it shall be assumed that anchors do not dissipate energy by means of ductile hysteretic behavior and do not contribute to the overall ductile behavior of the structure. Stand-off fastening or other configurations where anchors may be subjected to shear load with lever arm shall not be permitted under seismic conditions. Base plates with grout layer shall not be permitted under seismic conditions.

10.1.2 Location of Anchors

The gap between the base plate clearance hole and the anchor should be avoided in seismic conditions. If it is not possible to avoid this gap, then the factor α_{gap} shall be applied to account for the effect of this gap on behavior of the anchor. However, the clearance diameter d_f shall be limited to the values given in 7.3.1.

10.1.3 Applicability of Seismic Design Provisions

For all seismicity levels defined as per IS 1893, anchor shall be designed for seismic conditions. The design seismic force acting on the base plate shall be determined according to IS 1893 (Part 1) and other relevant standards.

NOTES

1 When the seismic tension component of the design force at the ultimate limit state applied to an individual anchor or an anchor group is equal to or less than 20 per cent of the total design tensile force, then seismic provisions in **10.2** need not apply for the verification of the tension component acting on a single anchor or a group of anchors.

2 When the seismic shear component of the design force at the ultimate limit state applied to an individual anchor or an anchor group is equal to or less than 20 per cent of the total design shear force, provisions in **10.2** need not apply for the verification of the shear component acting on a single anchor or a group of anchors.

3 The seismic forces may be considered for non-structural components also. Specialist literature may be consulted for understanding on how to derive seismic forces on anchor and how to account for amplification of seismic forces. Reference to IS 1893 or IS 16700 may be made in this regard for calculation of seismic force on non-structural elements.

10.2 Design Options

The anchor shall be designed for seismic condition as per **10.2.1** or **10.2.2** or **10.2.3**.

10.2.1 Capacity Design

As per this method, an individual anchor or an anchor group shall be designed for the maximum tension and/or shear load that can be transmitted to the anchor based on either the development of a ductile yield mechanism in the attached element (see Fig. 53A) or the base plate (see Fig. 53B) taking into account strain hardening and the capacity of a non-yielding attached element (or structural element) (see Fig. 53C).

NOTE – The assumption of a plastic hinge in the base plate (see Fig. 52B) requires to take into account aspects like the redistribution of loads to the individual anchors of a group, the redistribution of the loads in the structure, the fatigue behavior of the base plate, etc.

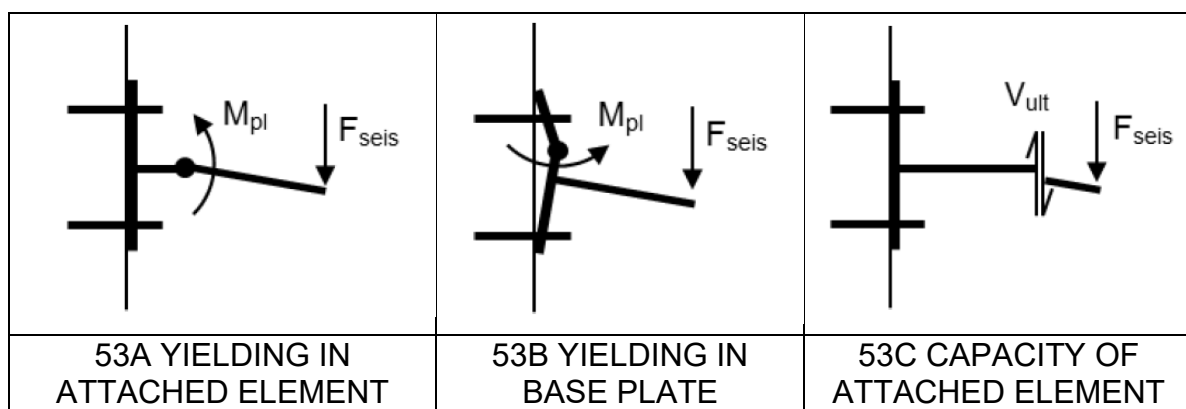

FIG. 53 SEISMIC DESIGN BY PROTECTION OF ANCHOR (see **10.2.1**)

10.2.2 Elastic Design

As per this method, an individual anchor or an anchor group shall be designed for the maximum load obtained from the design load combinations (including seismic) corresponding to the limit state (refer IS 1893 Part 1) assuming an elastic behavior of the anchorage and of the structure. Furthermore, uncertainties in the model to derive seismic forces on the anchorage shall be taken into account.

10.2.3 Design with Requirements on the Ductility of the Anchors

This method shall not be used for anchor connections of primary seismic members. This method may be used only for secondary/tertiary seismic member. As per this method, an individual anchor or an anchor group shall be designed for the maximum load obtained from the design load combinations (including seismic) corresponding to the limit state (refer IS 1893). The tension steel capacity of the anchor or anchor group shall be smaller than the tension capacity in concrete related failure modes. Elongation capacity of the anchors shall be such that it accommodates the deformation according to the seismic analysis of the connection.

10.2.3.1 For this design method, the following requirements shall apply:

- a) The anchor shall have technical assessment report (AR) that includes qualification for seismic performance.
- b) To ensure steel failure mechanism, following shall be satisfied:

For single anchor in tension: $N_{Rk,s,seis} \leq 0.7 N_{Rk,c,seis} / \gamma_{inst}$

For anchor group in tension: $\frac{N_{Rk,s,seis}}{N_{Ld,\sigma^*}} \leq 0.7 N_{Rk,c,seis} / (N_{Ld,g} \cdot \gamma_{inst})$

In addition to the above requirement, the following shall apply to the highest loaded anchor for group of mechanical anchor in tension:

$$N_{Rk,s,seis} \leq 0.7 N_{Rk,p,seis} / \gamma_{inst}$$

where,

$N_{Rk,s,seis}$ = Characteristic seismic steel strength

$N_{Rk,c,seis}$ = Characteristic seismic strength for all non-steel failure types like concrete cone, blowout and splitting failure.

$N_{Rk,p,seis}$ = Characteristic seismic pullout strength

γ_{inst} = Partial safety factor for installation safety.

N_{Ld,σ^*} = Design load on the most stressed anchor of an anchor group and

$N_{Ld,g}$ = Design load on the tensioned anchors of an anchor group.

- c) Anchors for tension load shall be ductile and shall have a stretch length of at least $8d_a$ (see Fig. 54) or more as per the analysis requirement.

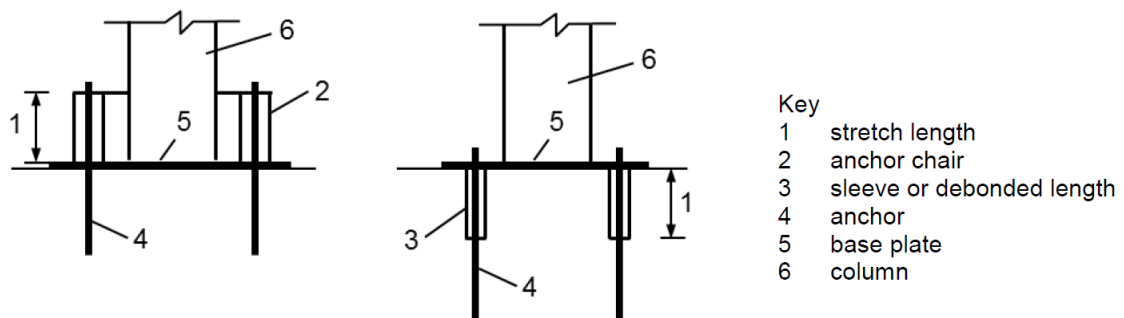

FIG. 54 SEISMIC DESIGN BY YIELDING OF A DUCTILE ANCHOR – ILLUSTRATION OF STRETCH LENGTH

- d) An anchor shall be considered as ductile if the nominal steel yield strength (f_y) of the load transferring section does not exceed 650 MPa, the ratio of nominal yield strength (f_y) to nominal ultimate strength (f_u) does not exceed 0.8, and the rupture elongation (measured over a length of $5d_a$) is at least 12 percent.
- e) The characteristic steel strength (resistance) of the anchors that incorporate a reduced section over a length smaller than $8d_{a,red}$ ($d_{a,red}$ = anchor diameter of reduced section) shall be greater than 1.3 times the characteristic yield capacity (resistance) of the unreduced section as per AR.

10.3 Design Method

The design strength shall be calculated according to limit state of design for all load directions namely, tension, shear individually or combined as well as for all applicable failure modes. The minimum strength shall govern for each load direction.

10.3.1 Partial Safety Factors

Partial safety factor of material for static design (see 9.2.1) shall also be applicable for seismic design.

10.3.2 Design Check in Tension and Shear

The design strength in tension and shear shall be calculated and checked according to limit state of design for all applicable failure modes as per Table 3. The minimum strength shall govern for each load direction.

Table 3 Design Strength Checks in Tension and Shear for Seismic Design

(Clause 10.3.2)

SI No.	Parameter	Checks for Anchor
(1)	(2)	(3)
	Strength to resist expected failure types in tension	
a)	Steel strength	$N_{Ld,seis} \leq N_{Rk,s,seis}/\gamma_{Ms}$
b)	Concrete cone strength	$N_{Ld,seis} \leq N_{Rk,c,seis}/\gamma_{Mc}$
c)	Pull-out strength (MA) (see Note 1)	$N_{Ld,seis} \leq N_{Rk,p,seis}/\gamma_{Mp}$
d)	Pull-out strength (AA) (see Note 1)	$N_{Ld,seis} \leq N_{Rk,p,seis}/\gamma_{Mp}$
e)	Splitting strength (see Note 3)	$N_{Ld,seis} \leq N_{Rk,sp,seis}/\gamma_{Msp}$
ii)	Strength to resist expected failure types in shear	
a)	Steel strength (For shear load without lever arm) (see Note 2)	$V_{Ld,seis} \leq V_{Rk,s,seis}/\gamma_{Ms}$
b)	Concrete pry-out strength	$V_{Ld,seis} \leq V_{Rk,cp,seis}/\gamma_{Mc}$
c)	Concrete edge strength	$V_{Ld,seis} \leq V_{Rk,c,seis}/\gamma_{Mc}$

NOTES

1 MA – Mechanical anchor and AA – Adhesive anchor.

2 Steel failure for shear load with lever arm is not covered in this standard.

3 Check for splitting failure shall not be required if cracked concrete is assumed and reinforcement is available in base material (that is concrete) to resist splitting forces.

10.3.2.1 Determination of characteristic strength

The characteristic strength for an anchor or an anchor group shall be determined for each failure type as follows:

$$R_{Rk,seis} = \alpha_{gap} \alpha_{seis} R_{Rk,seis}^0$$

where

α_{gap} = Reduction factor to account for inertia effects due to any gap between anchor and base plate in shear; as given in the relevant AR.

NOTE – If α_{gap} value is not available in AR then α_{gap} may be assumed to be 1.0 in case of no hole clearance between anchor and base plate and 0.5 in case of connections with hole clearance (d_{fix}) as given in 7.3.1.

α_{seis} = Reduction factor to account for the influence of large cracks and scatter of load-displacement curves (see Table 4)

$R_{Rk,seis}^0$ = Characteristic seismic resistance of a single anchor for a given failure mode and not influenced by adjacent fasteners or edges of the concrete member determined as per Table 5.

Table 4 Reduction Factor for Seismic Design α_{seis}
(Clause 10.3.2.1)

SI No.	Parameter	For Single Anchor	For Anchor Group
(1)	(2)	(3)	(4)
1)	Failure type in tension		
a)	Steel failure	1	1
b)	Concrete cone failure		
	i) Undercut anchor	1	0.85
	ii) All other anchors	0.85	0.75
c)	Pull-out failure for mechanical anchor	1	0.85
d)	Pull-out failure adhesive anchor	1	0.85
e)	Splitting failure	1	0.85
2)	Failure type in shear		
a)	Steel failure (For shear load without lever arm	1	0.85
b)	Concrete pry-out failure		
	i) Undercut anchor	1	0.85
	ii) All other anchors	0.85	0.75
c)	Concrete edge failure	1	0.85

Table 5 Determination of $R_{Rk,seis}^0$
(Clause 10.3.2.1)

Sl No.	Parameter	Method of Determination of Characteristic Seismic Resistance $R_{Rk,seis}^0$
(1)	(2)	(3)
i)	Strength to resists expected failure types in tension	
a)	Steel strength	As per AR of the anchor
b)	Concrete cone strength	Same as that for static condition (See 7.2)
c)	Pull-out strength for mechanical anchor	As per AR of the anchor
d)	Pull-out strength for Adhesive Anchor	As per 7.2.2.4 using the characteristic bond resistance for seismic $\tau_{Rk,seis}$ as per AR shall be used
e)	Splitting strength	Same as that for static condition (see 7.2)
ii)	Strength to resists expected failure types in shear	
a)	Steel strength (For shear load without lever arm)	As per AR of the anchor
b)	Concrete pry-out strength	Same as that for static condition (see 7.2)
c)	Concrete edge strength	Only first row of anchor to be considered. (see 7.2)

NOTE – The design of fastenings under earthquake loading for earthquake zones III and above and for important building classes (as per NBC 2016 and IS 1893) shall be based on an assessment under pulsating tension, crack cycling under constant tension load and alternating shear in cracked concrete at a crack width of 0.8 mm.

10.3.3 Check for Combined Tension and Shear

The following equations shall be satisfied for combined tension and shear loads:

$$N_{Ld,seis}/N_{Rd,seis} \leq 1$$

$$V_{Ld,seis}/V_{Rd,seis} \leq 1$$

$$\left(N_{Ld,seis}/N_{Rd,seis}\right) + \left(V_{Ld,seis}/V_{Rd,seis}\right) \leq 1$$

where the largest ratio for $N_{Ld,seis}/N_{Rd,seis}$ and $V_{Ld,seis}/V_{Rd,seis}$ for different failure types shall be inserted in the above equations. The interaction checks shall be separately performed for steel and concrete failures.

10.3.4 Displacements

The anchor displacement under tensile and shear load at limit state of displacement shall be limited to $\delta_{N,req(DLS)}$ and $\delta_{V,req(DLS)}$ value of the application to meet requirements regarding functionality and assumed support conditions. If anchor and attached elements are expected to be operational after an earthquake then relevant anchor displacements shall be taken into account. If the anchor displacements $\delta_{N,seis(DLS)}$ under tension loading and/or $\delta_{V,seis(DLS)}$ under shear load provided in the relevant AR are higher than the corresponding required values $\delta_{N,req(DLS)}$ and/or $\delta_{V,req(DLS)}$, the design resistance may be reduced according to the following equations:

$$N_{Rd,seis,red} = N_{Rd,seis} \frac{\delta_{N,req(DLS)}}{\delta_{N,seis(DLS)}}$$

$$V_{Rd,seis,red} = V_{Rd,seis} \frac{\delta_{V,req(DLS)}}{\delta_{V,seis(DLS)}}$$

NOTE – When a rigid support is assumed in the analysis the designer shall establish the limiting displacement compatible to the requirement for the structural behavior. The acceptable displacement associated to a rigid support condition is considered to be 3 mm.

If the connection such as façade element is designed to accommodate deformations (that is displacements or rotations) then it shall be demonstrated that the anchor can accommodate these deformations. The rotation of a connection θ (see Fig. 55) is given by

$$\theta = \delta_{N,seis} / s'_{max}$$

where,

$\delta_{N,seis}$ = Displacement of the anchor (limited to 3 mm) when subjected to earthquake load

s'_{max} = Distance between the outermost row of anchors and the opposite edge of the base plate

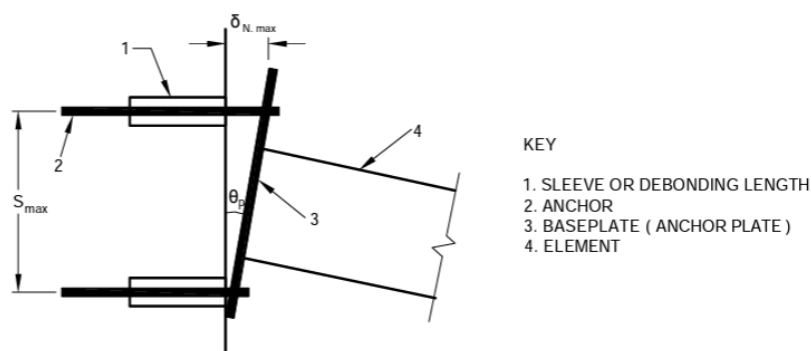

FIG. 55 EXAMPLE OF ROTATION AND DISPLACEMENT OF A CONNECTION

11 ADDITIONAL CHECKS AND REQUIREMENTS

11.1 General

To establish the transmission of the anchor loads to the supports of the concrete member, basic checks shall be carried out with due consideration of the loads introduced by the anchors along with additional provisions given in this section.

NOTE – In the case of slabs and beams made out of prefabricated units and added cast-in-situ concrete, anchor loads may be transmitted into the prefabricated concrete only if the precast concrete is connected with the cast-in-situ concrete by shear reinforcement. If this shear reinforcement between precast and cast-in-situ concrete is not present, the anchors shall be designed as per the provisions of this standard.

11.2 Shear Strength of Concrete Member

The shear forces V_{Lda} caused by anchor loads shall not exceed the value $0.4V_{Rd1}$; where V_{Rd1} is design shear strength of concrete according to IS 456. When calculating V_{Lda} the anchor loads shall be assumed as point loads with a width of load application $t_1 = s'_{t1} + 2h_{ef}$ and $t_2 = s'_{t2} + 2h_{ef}$, where s'_{t1} and s'_{t2} is spacing between the outer anchors of a group in direction 1 and 2, respectively.

11.3 Resistance of Concrete Member to Splitting

The splitting forces generated by anchors shall be taken into account while designing the concrete member. This requirement may be neglected if one of the following conditions is met:

- a) The load transfer area that is the embedment length along which load is transferred) of anchor is in the compression zone of the concrete member.
- b) The tension component of the characteristic loads acting on the single anchor or anchor group is less than 10 kN.

If tension component of the characteristic loads is greater than 10 kN but less than 30 kN, the splitting check may still be neglected

- a) if the area of the transverse reinforcement is at least 60 percent of the longitudinal reinforcement required for the loads due to anchor loads.
- b) For fastenings in slabs and walls wherever reinforcement in both directions is present as per IS 456 in the region of the anchorage.

If the tension component of the characteristic loads acting on the anchorage is greater than or equal to 30 kN and the anchors are located in the tension zone of the concrete member then the splitting forces shall be taken up by reinforcement. The ratio between splitting force $F_{Rk,sp}$ and the tension component of the characteristic loads $N_{L,Rk}$ shall be taken as:

$$F_{Rk,sp} = 0.5 N_{L,Rk} , \text{ for adhesive anchors}$$

$$F_{Rk,sp} = 1.5 N_{L,Rk}, \text{ for torque controlled expansion anchors}$$

$$F_{Rk,sp} = 1.0 N_{L,Rk} , \text{ for undercut (mechanical) anchors}$$

$$F_{Rk,sp} = 2.0 N_{L,Rk} , \text{ for deformation controlled expansion anchors}$$

ANNEX A**LIST OF CROSS REFERRED INDIAN STANDARDS**

<i>IS No.</i>	<i>Title</i>
CED 02(25735)	Draft standard on Testing and Assessment of Post-installed mechanical anchoring systems
CED 02(25734)	Draft standard on Testing and Assessment of Post-Installed adhesive anchoring systems
1608 (Part 1)	Mechanical testing of metals - Tensile testing
1893 (Part1):2016	Criteria for earthquake resistant design of structures (<i>sixth revision</i>)
456 :2000	Plain and reinforced concrete - Code of practice (<i>fourth revision</i>)
875 (Part 1) : 1987	Code of practice for design loads (Other Than Earthquake) for buildings and structures: Part 1 dead loads - Unit weights of building materials and stored materials (<i>second revision</i>)
875 (Part 2) : 1987	Code of practice for design loads (Other Than Earthquake) for buildings and structures: Part 2 imposed loads. (<i>second revision</i>)
875 (Part 3) : 2015	Design Loads (Other than Earthquake) for Buildings and Structures - Code of Practice Part 3 Wind Loads (<i>third revision</i>)
875 (Part 4) : 2021	Code of practice for design loads other than earthquake for Buildings and Structures Part 4 Snow Loads
875 (Part 5) : 1987	Code of practice for design loads (Other Than Earthquake) for buildings and structures: Part 5 special loads and load combinations (<i>second revision</i>)
16700 : 2023	Criteria for structural safety of tall concrete buildings (<i>first revision</i>)

ANNEX B

ILLUSTRATION OF SHEAR LOAD VERIFICATION FOR DIFFERENT LOAD COMBINATIONS WHEN HOLES ARE FILLED UP

B.1 Only shear force acting towards the edge

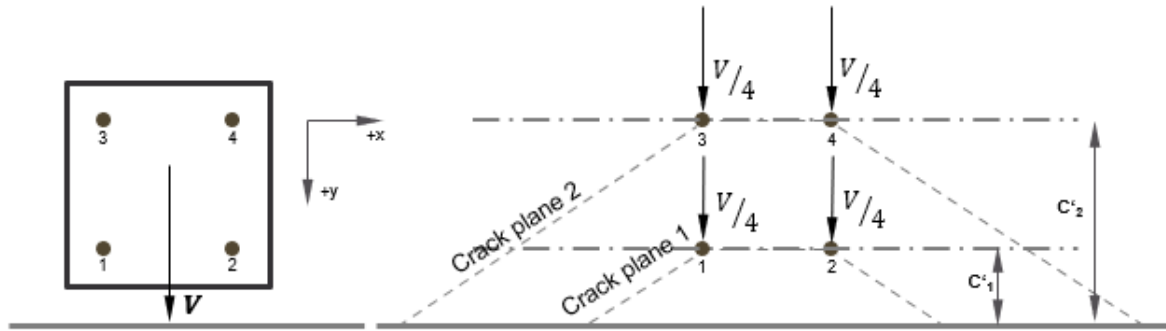

Crack Plane	Loads to be considered	Resistance to be considered
Crack Plane 1	$V_V = V/2$	Resistance considering $c' = c'_1$
Crack Plane 2	$V_V = V$	Resistance considering $c' = c'_2$

B.2 Shear force verification due to torsion

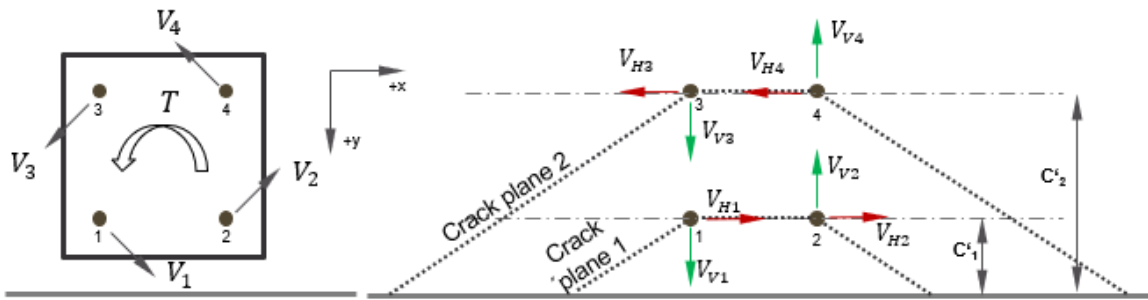

Crack Plane	Loads to be considered	Resistance to be considered
Crack Plane 1	$V_H = V_{H1} + V_{H2}$ $V_V = V_{V1}$	Resistance considering $c' = c'_1$
Crack Plane 2	$V_H = V_{H3} + V_{H4}$ $V_V = V_{V1} + V_{V3}$	Resistance considering $c' = c'_2$

B.3 Shear force verification due to combination of shear force and torsion acting simultaneously

a) Shear load parallel to edge

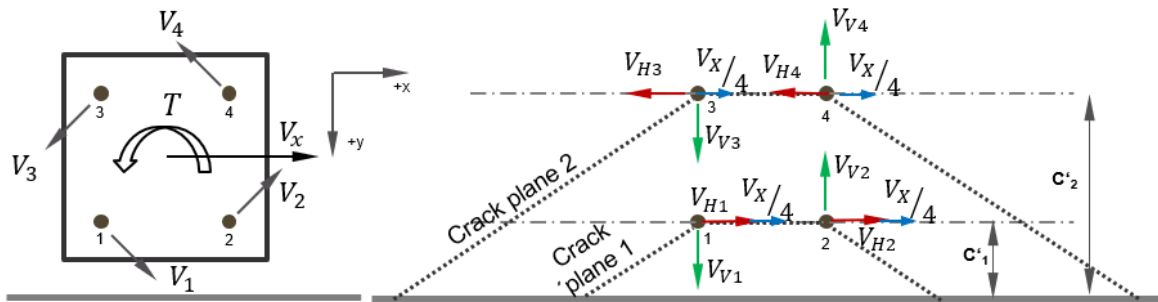

Crack Plane	Loads to be considered	Resistance to be considered
Crack Plane 1	$V_H = V_{H1} + V_{H2} + V_x/2$ $V_v = V_{V1}$	Resistance considering $c' = c'_1$
Crack Plane 2	$V_H = V_{H3} + V_{H4} + V_x/2$ $V_v = V_{V1} + V_{V3}$	Resistance considering $c' = c'_2$

b) Shear load towards the edge

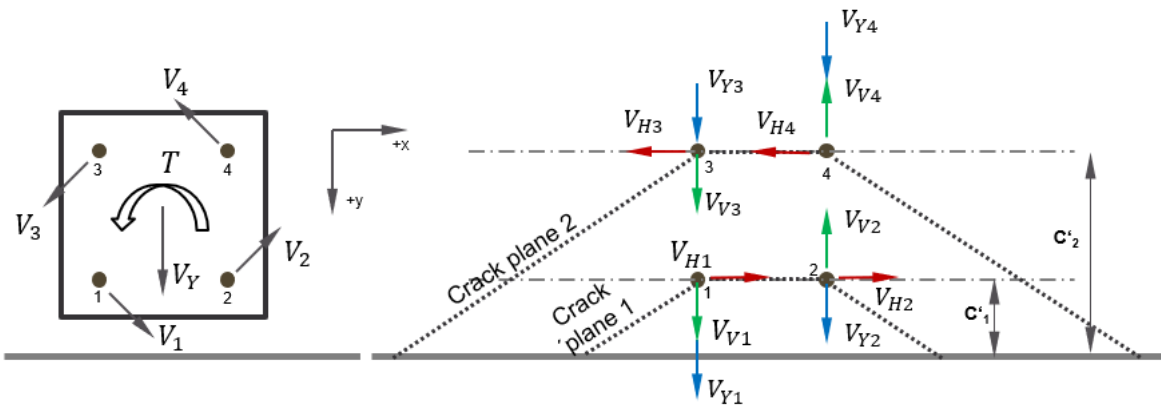

Crack Plane	Loads to be considered	Resistance to be considered
Crack Plane 1	$V_H = V_{H1} + V_{H2}$ $V_v = V_{V1} + V_y/2$	Resistance considering $c' = c'_1$
Crack Plane 2	$V_H = V_{H3} + V_{H4}$ $V_v = V_{V1} + V_{V3} + V_y$	Resistance considering $c' = c'_2$

NOTE – All the resolved forces on the anchors are to be considered as concentric with the anchors.

ANNEX C
(Foreword)

INSTALLATION AND INSPECTION

Installation of anchors shall be in accordance with the manufacturer printed installed instruction (MPII) and safety data sheet for the respective anchor. The anchor installation should be undertaken by installers who have been adequately trained by a competent trainer or manufacturer. The installer should be familiar with the correct installation procedures and ensure that the correct drilling and setting tools are available for the proper installation of the anchor.

Following installation and prior to loading, the anchors should be inspected so that any observations regarding rotation, movement, deformation, cracking, or other damage can be recorded and communicated to the concerned engineer-in-charge for corrective measures.

Testing of anchors on site may be required after installation to validate the quality of installation. These proof tests should be carried out on a sample of working anchors on safety-critical application (unless approved anchors have been installed by trained operators working under supervision), after the anchors have been installed, to ensure that they have been installed correctly. The tests are intended to demonstrate that anchors to be used in service have a modest safety margin without risking their integrity. Detailed guideline in this regard is under development.

Users of anchors are encouraged to verify the testing/assessment reports issued by reputed bodies who would demonstrate independently the above mentioned criteria.

ANNEX D

(Committee composition will be added after finalization)
