

वस्त्रादि — जूट ब्रॉड लूमस के लिए
शटल्स — विशिष्टि
(दूसरा पुनरीक्षण)

**Textiles — Shuttles for Jute Broad
Looms — Specification**
(*Second Revision*)

ICS 59.120.30

© BIS 2024



भारतीय मानक ब्यूरो
BUREAU OF INDIAN STANDARDS
मानक भवन, 9 बहादुर शाह ज़फर मार्ग, नई दिल्ली - 110002
MANAK BHAVAN, 9 BAHADUR SHAH ZAFAR MARG
NEW DELHI - 110002
www.bis.gov.in www.standardsbis.in

FOREWORD

This Indian Standard (Second Revision) was adopted by the Bureau of Indian Standards, after the draft finalized by the Textile Machinery and Accessories Sectional Committee had been approved by the Textiles Division Council.

A shuttle is a tool designed to neatly and compactly store a holder that carries the thread of the weft yarn while weaving with a loom. Shuttles are thrown or passed back and forth through the shed, between the yarn threads of the warp in order to weave in the weft.

This standard was first published in 1964 and subsequently revised in 1971. This revision has been brought out to incorporate the following changes:

- a) Forward has been incorporated;
- b) Scope of the standard has been incorporated;
- c) Reference clause has been incorporated;
- d) Marking clause has been modified; and
- e) Sampling clause has been incorporated.

The composition of the Committee responsible for the formulation of this standard is given in [Annex A](#).

For the purpose of deciding whether a particular requirement of this standard is complied with, the final value, observed or calculated, expressing the result of a test, shall be rounded off in accordance with IS 2 : 2022 'Rules for rounding off numerical values (*second revision*)'. The number of significant places retained in the rounded off value should be the same as that of the specified value in this standard.

Indian Standard

**TEXTILES — SHUTTLES FOR JUTE BROAD LOOMS —
SPECIFICATION**

(*Second Revision*)

1 SCOPE

This standard prescribes the requirements of the shuttle used in jute broad looms.

2 REFERENCES

The standards given below contain provisions which, through reference in this text, constitute provisions of this standard. At the time of publication, the editions indicated were valid. All standards are subject to revision, and parties to agreements based on this standard are encouraged to investigate the possibility of applying the most recent edition of these standards:

<i>IS No.</i>	<i>Title</i>
IS 196 : 1966	Atmospheric conditions for testing (<i>revised</i>)
IS 1141 : 1993	Seasoning of timber — Code of practice (<i>second revision</i>)
IS 2500 (Part 1) : 2000/ISO 2859 -1 : 1999	Sampling procedure for inspection by attributes: Part 1 Sampling schemes indexed by acceptance quality limit (AQL) for lot-by-lot inspection (<i>third revision</i>)
IS 5944 : 1971	Specification for accessories for use in shuttles for jute looms

3 SHAPE AND DIMENSIONS

The shape and dimensions of shuttle shall be as shown in [Fig. 1](#) when read with [Table 1](#).

4 MATERIAL

As agreed to between the buyer and the seller, the body of the shuttle shall be made of natural wood or solid compressed from or compressed laminated wood having solid wood as center piece and veneer laminations on the sides.

5 SHUTTLE ACCESSORIES

Various accessories used in making shuttles shall preferably conform to the relevant requirements laid down in IS 5944.

6 WEIGHT

The weight of individual shuttle shall be $1\ 550\text{ g} \pm 175\text{ g}$.

7 WORKMANSHIP AND FINISH

7.1 Tire wood for the manufacture of shuttles shall be fully seasoned (*see* IS 1141).

NOTE — If an agreement between the buyer and the seller so provides, the shuttles made of natural uncompressed wood shall be soaked in raw linseed, groundnut, mineral (spindle), or sperm oil immediately after manufacture for 12 h and then allowed to stand for another 12 h to drain off excess oil.

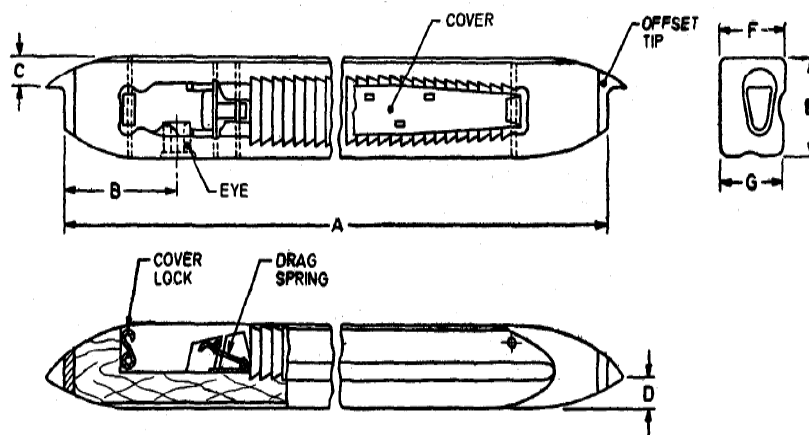

All dimensions in millimetres.

FIG. 1 A TYPICAL SHUTTLE FOR JUTE BROAD LOOMS

To access Indian Standards click on the link below:

https://www.services.bis.gov.in/php/BIS_2.0/bisconnect/knowyourstandards/Indian_standards/isdetails/

Table 1 Dimensions of Shuttle for Jute Broad looms

(Clause 3)

Sl No.	Variety No.	Full Cop Dimensions		Shuttle Dimensions							Number of Grooves per 25 mm
		Overall Length of Cop Max	Cop Diameter Max	A	B	C	D	E	F	G	
(1)	(2)	(3)	(4)	(5)	(6)	(7)	(8)	(9)	(10)	(11)	(12)
i)	B ₁	305	45	612	125	21	21	64	53	51	4
ii)	B ₂	355	45	612	110	21	21	64	53	51	4
iii)	B ₃	380	45	612	99	21	21	66	53	51	4
Tolerance, mm	–	–	–	± 2	± 1	± 1	± 1	± 0.5	± 1	± 1	–

7.2 Shuttles shall be free from big knots, cracks and any other visible defect which is likely to affect the life or usefulness of shuttles.

7.3 The surface shall be sanded smooth.

7.4 Angle of shuttle (bevel) shall normally be $86^\circ \pm 1^\circ$.

8 ATMOSPHERIC CONDITIONS FOR CONDITIONING AND TESTING

In case of dispute or if agreed to between the buyer and the seller, the test sample shall be conditioned to moisture equilibrium and tested in the standard atmospheric conditions, that is, 65 percent ± 2 percent relative humidity and $27^\circ\text{C} \pm 2^\circ\text{C}$ temperature (see IS 196).

9 SAMPLING

9.1 Lot

In any consignment, the number of shuttles delivered to a buyer against a dispatch note, shall constitute a lot.

9.2 Unless otherwise agreed to between the buyer and the seller, the number of shuttles to be selected for inspection, shall be according to col (2) and col (3) of [Table 2](#) [see IS 2500 (Part 1)].

9.3 Criteria for Conformity

The lot shall be considered conforming to the requirements if the following conditions are satisfied

Sl No.	Characteristic(s)	Number of Samples	Criteria for Conformity
(1)	(2)	(3)	(4)
i)	Shape and dimensions	According to col (3) of Table 2	Number of defective shuttles shall not exceed the corresponding number given in col (5) of Table 2
ii)	Material and all other requirements	According to col (4) of Table 2	All shuttles meet the relevant requirements

Table 2 Sample Size and Permissible Number of Defectives

(Clauses 9.2 and 9.3)

Sl No.	Lot Size	Sample Size	Sub-sample Size	Permissible Number of Defectives
(1)	(2)	(3)	(4)	(5)
i)	Up to 150	8	3	1
ii)	151 to 280	13	3	1
iii)	281 to 500	20	3	2
iv)	501 and above	32	5	3

10 MARKING

Each shuttle shall bear the name of manufacturer or trade-mark, and a code number to trace the month and year of manufacture.

10.1 Each shuttle for the jute broad looms shall also bear the following information:

- a) Type of the wood used in the shuttle;
- b) Net weight of the content;
- c) Code number to trace back the history of production;
- d) Hand of the shuttle whether right hand (R) or left hand (L);
- e) Dimension of the shuttle;
- f) Number of shuttles in lot;
- g) Gross and net mass;
- h) Lot/Batch number;

- j) Country of origin; and
- k) Any other information required by the law in force and/or by the buyer.

10.2 BIS Certification Marking

The product(s) conforming to the requirements of this standard may be certified as per the conformity assessment schemes under the provisions of the *Bureau of Indian Standards Act, 2016* and the Rules and Regulations framed thereunder, and the products may be marked with the Standard Mark.

11 PACKING

Shuttles shall be suitably packed as may be agreed to between the concerned parties. The package should contain fixed number of Shuttles essentially of the same variety.

ANNEX A

(Foreword)

COMMITTEE COMPOSITION

Textile Machinery and Accessories Sectional Committee, TXD 14

<i>Organization</i>	<i>Representative(s)</i>
Central Manufacturing Technology Institute, Bengaluru	DR NAGAHANUMAIAAN (<i>Chairperson</i>)
ATE Enterprises Private Limited, New Delhi	SHRI ABHIJIT KULKARNI SHRI ANIL KUMAR SHARMA (<i>Alternate</i>)
Bajaj Industries Private Limited, Kolkata	REPRESENTATIVE
Bhowmick Calculator, Kolkata	SHRI GOUTAM BHOWMICK SHRI VIVEKANANDA BHOWMICK (<i>Alternate</i>)
Bombay Textile Research Association, Mumbai	SHRI VIJAY GAWDE SHRI R. A. SHAIKH (<i>Alternate</i>)
Central Manufacturing Technology Institute, Bengaluru	SHRI B. R. MOHANRAJ SHRI K. SARAVANAN (<i>Alternate</i>)
Confederation of Indian Textile Industry, New Delhi	SHRIMATI CHANDRIMA CHATTERJEE SHRI ANMOL GUPTA (<i>Alternate</i>)
ICAR - Central Institute for Research on Cotton Technology, Mumbai	DR N. SHANMUGAM DR T. SENTHIL KUMAR (<i>Alternate</i>)
India ITME Society, Mumbai	SHRI S. SENTHIL KUMAR SHRIMATI SEEMA SRIVASTAVA (<i>Alternate</i>)
Indian Jute Industries Research Association, Kolkata	SHRIMATI SAUMITA CHOUDHURY SHRI PARTHA SANYAL (<i>Alternate</i>)
Indian Jute Mills Association, Kolkata	SHRI BHUDIPTA SAHA SHRI TANMOY SINGHA (<i>Alternate</i>)
Indian Textile Accessories and Machinery Manufacturers Association, Mumbai	SHRI N. D. MHATRE SHRI CHANDRESH SHAH (<i>Alternate</i>)
Inspiron Engineering Private Limited, Ahmedabad	SHRI ANKUR SONI
Kusters Calico Machinery Limited, Karjan	SHRI DEVANG PARIKH SHRI SHUBHASIS SUR (<i>Alternate</i>)
Lagan Engineering Company Limited, Kolkata	REPRESENTATIVE
Lakshmi Machine Works Limited, Coimbatore	SHRIMATI KALPANA A. SHRIMATI DIVYA V. (<i>Alternate</i>)

<i>Organization</i>	<i>Representative(s)</i>
Laxmi Shuttleless Looms Private Limited, Ahmedabad	SHRI KETAN SANGHVI
Ludlow Jute Limited, Kolkata	REPRESENTATIVE
Ministry of Heavy Industries and Public Enterprises, Department of Heavy Industry, New Delhi	SHRI SANJEEV GUPTA SHRI S. SUNDAR
National Safety Council, Navi Mumbai	SHRI LALIT R. GABHANE SHRI R. R. DEOGHARE (<i>Alternate</i>)
Office of the Textile Commissioner, Mumbai	SHRI N. K. SINGH SHRI NAROTTAM KUMAR (<i>Alternate</i>)
Peass Industrial Engineers Private Limited, Navsari	SHRI RAVI S. RAO SHRI NAIMISHKUMAR RAMANLAL TANDEL (<i>Alternate</i>)
Synthetic and Art Silk Mills Research Association, Mumbai	DR MANISHA MATHUR SHRI SANJAY SAINI (<i>Alternate</i>)
Technocraft Industries India Limited, Mumbai	SHRI RAVINDER KUMAR SHRI R. MURALI (<i>Alternate</i>)
Truetzschler India Private Limited, Ahmedabad	SHRI PRAVIN KANDGE SHRI SHILADITYA JOSHI (<i>Alternate</i>)
Veer mata Jijabai Technological Institute, Mumbai	DR SURANJANA GANGOPADHYAY DR S. P. BORKAR (<i>Alternate</i>)
BIS Directorate General	SHRI J. K. GUPTA, SCIENTIST 'E'/DIRECTOR AND HEAD (TEXTILES) [REPRESENTING DIRECTOR GENERAL (<i>Ex-officio</i>)]

Member Secretary
SHRI SWAPNIL
SCIENTIST 'B'/ASSISTANT DIRECTOR
(TEXTILES), BIS

Bureau of Indian Standards

BIS is a statutory institution established under the *Bureau of Indian Standards Act, 2016* to promote harmonious development of the activities of standardization, marking and quality certification of goods and attending to connected matters in the country.

Copyright

BIS has the copyright of all its publications. No part of these publications may be reproduced in any form without the prior permission in writing of BIS. This does not preclude the free use, in the course of implementing the standard, of necessary details, such as symbols and sizes, type or grade designations. Enquiries relating to copyright be addressed to the Head (Publication & Sales), BIS.

Review of Indian Standards

Amendments are issued to standards as the need arises on the basis of comments. Standards are also reviewed periodically; a standard along with amendments is reaffirmed when such review indicates that no changes are needed; if the review indicates that changes are needed, it is taken up for revision. Users of Indian Standards should ascertain that they are in possession of the latest amendments or edition by referring to the website-www.bis.gov.in or www.standardsbis.in.

This Indian Standard has been developed from Doc No.: TXD 14 (24703).

Amendments Issued Since Publication

Amend No.	Date of Issue	Text Affected

BUREAU OF INDIAN STANDARDS

Headquarters:

Manak Bhavan, 9 Bahadur Shah Zafar Marg, New Delhi 110002

Telephones: 2323 0131, 2323 3375, 2323 9402

Website: www.bis.gov.in

Regional Offices:

Central : 601/A, Konnectus Tower -1, 6th Floor,
DMRC Building, Bhavbhuti Marg, New
Delhi 110002

Telephones

{ 2323 7617

Eastern : 8th Floor, Plot No 7/7 & 7/8, CP Block, Sector V,
Salt Lake, Kolkata, West Bengal 700091

{ 2367 0012
2320 9474

Northern : Plot No. 4-A, Sector 27-B, Madhya Marg,
Chandigarh 160019

{ 265 9930

Southern : C.I.T. Campus, IV Cross Road, Taramani, Chennai 600113

{ 2254 1442
2254 1216

Western : Manakalya, 5th Floor/MTNL CETTM, Technology Street, Hiranandani Gardens, Powai
Mumbai 400076

{ 25700030
25702715

Branches : AHMEDABAD, BENGALURU, BHOPAL, BHUBANESHWAR, CHANDIGARH, CHENNAI, COIMBATORE, DEHRADUN, DELHI, FARIDABAD, GHAZIABAD, GUWAHATI, HARYANA (CHANDIGARH), HUBLI, HYDERABAD, JAIPUR, JAMMU, JAMSHEDPUR, KOCHI, KOLKATA, LUCKNOW, MADURAI, MUMBAI, NAGPUR, NOIDA, PARWANOO, PATNA, PUNE, RAIPUR, RAJKOT, SURAT, VIJAYAWADA.