कार्बन फाइबर — रेजिन-इंप्रेग्नेटेड धागे के
तन्व्य गुणों का निर्धारण

Carbon Fibre — Determination of
Tensile Properties of Resin-
Impregnated Yarn

ICS 59.100.20

© BIS 2023
© ISO 2004



भारतीय मानक ब्यूरो
BUREAU OF INDIAN STANDARDS
मानक भवन, 9 बहादुर शाह ज़फर मार्ग, नई दिल्ली - 110002
MANAK BHAVAN, 9 BAHADUR SHAH ZAFAR MARG
NEW DELHI - 110002
www.bis.gov.in www.standardsbis.in

NATIONAL FOREWORD

This Indian Standard which is identical to ISO 10618 : 2004 'Carbon fibre — Determination of tensile properties of resin-impregnated yarn' issued by the International Organization for Standardization (ISO) was adopted by the Bureau of Indian Standards on recommendation of High Performance Fibres, Fibrous Structure and Textile Components of Composites Sectional Committee and approval of the Textiles Division Council.

The text of ISO standard has been approved as suitable for publication as an Indian Standard without deviations. Certain conventions are, however, not identical to those used in Indian Standards. Attention is particularly drawn to the following:

- a) Wherever the words 'International Standard' appear referring to this standard, they should be read as 'Indian Standard'; and
- b) Comma (,) has been used as a decimal marker, while in Indian Standards, the current practice is to use a point (.) as the decimal marker.

In this adopted standard reference appears to certain International Standards for which Indian Standards also exist. The corresponding Indian Standards which are to be substituted in their place, are listed below along with their degree of equivalence for the editions indicated:

<i>International Standard</i>	<i>Corresponding Indian Standard</i>	<i>Degree of Equivalence</i>
ISO 291 Plastics — Standard atmospheres for conditioning and testing	IS 13360 (Part 1) : 1992 Plastics — Methods of testing: Part 1 Introduction	Technically Equivalent
ISO 527-1 : 1993 Plastics — Determination of tensile properties — Part 1: General principles	IS 13360 (Part 5/Sec 1) : 2021/ISO 527-1 : 2019 Plastics — Methods of testing: Part 5 Mechanical properties, Section 1 Determination of tensile properties — General requirements (<i>second revision</i>)	Identical
ISO 1889 : 1997 Reinforcement yarns — Determination of linear density	IS 17298 : 2019/ISO 1889 : 2009 Reinforcement yarns — Determination of linear density	Identical
ISO 10119 Carbon fibre — Determination of density	IS 17306 : 2019/ISO 10119 : 2002 Carbon fibre — Determination of density	Identical
ISO 10548 Carbon fibre — Determination of size content	IS 17605 : 2021/ISO 10548 : 2002 Carbon fibre — Determination of size content	Identical

In reporting the result of a test or analysis made in accordance with this standard, if the final value, observed or calculated, is to be rounded off, it shall be done in accordance with IS 2 : 2022 'Rules for rounding off numerical values (*second revision*)'.

Contents

Page

1	Scope.....	1
2	Normative references	1
3	Terms and definitions	1
4	Symbols	1
5	Principle	2
6	Apparatus and materials	2
7	Test specimens	3
8	Atmosphere for conditioning and testing	5
9	Procedure for tensile testing	5
10	Expression of results.....	6
11	Precision	8
12	Test report.....	8
Annex A (informative) Examples of heat-curable epoxy-resin systems		10
Annex B (informative) Examples of impregnating apparatus		12
Annex C (informative) Examples of tabs and tab-preparation apparatus		13
Annex D (informative) Examples of extensometers.....		15

Indian Standard

CARBON FIBRE — DETERMINATION OF TENSILE PROPERTIES OF RESIN-IMPREGNATED YARN

1 Scope

This International Standard specifies a method of test for the determination of the tensile strength, tensile modulus of elasticity and strain at maximum load of a resin-impregnated yarn specimen. The method is applicable to yarns (continuous and staple-fibre yarns) of carbon fibre for use as reinforcements in composite materials.

2 Normative references

The following referenced documents are indispensable for the application of this document. For dated references, only the edition cited applies. For undated references, the latest edition of the referenced document (including any amendments) applies.

ISO 291, *Plastics — Standard atmospheres for conditioning and testing*

ISO 527-1, *Plastics — Determination of tensile properties — Part 1: General principles*

ISO 1889, *Reinforcement yarns — Determination of linear density*

ISO 10119, *Carbon fibre — Determination of density*

ISO 10548, *Carbon fibre — Determination of size content*

3 Terms and definitions

For the purposes of this document, the terms and definitions given in ISO 527-1 and the following apply.

3.1

cross-sectional area of carbon-fibre yarn

A_f

the linear density of the yarn divided by the density of the carbon fibre

NOTE It is expressed in square millimetres.

4 Symbols

The symbols used in this International Standard are as follows:

σ_f tensile strength, in megapascals;

F_f maximum tensile force, in newtons;

A_f cross-sectional area of yarn, in square millimetres;

- ρ_f density of yarn, in grams per cubic centimetre;
- T_{ff} linear density of yarn, in tex;
- T_{fi} linear density of impregnated yarn, in tex;
- E_f tensile modulus of elasticity, in gigapascals;
- L_0 gauge length of extensometer, in millimetres;
- ΔL variation in the length, in millimetres, corresponding to the variation in the force, in newtons;
- ΔF variation in the force, in newtons, corresponding to the variation in the length, in millimetres.

5 Principle

A sample of yarn is uniformly impregnated with resin, then cured to provide test specimens. The specimens are loaded in tension at a constant speed by a suitable mechanical testing machine until failure.

The tensile strength, the tensile modulus of elasticity and the strain at maximum load are calculated from the force-extension relationship.

The tensile modulus is determined by dividing the variation in the stress by the corresponding variation in the strain between two defined points. For carbon-fibre yarns, the relation between stress and strain is not linear, hence a chord modulus must be defined. In method A, the modulus is defined between two strain levels and in method B it is defined between two load levels. The linear density and the size content have to be determined independently.

NOTE The precision of the values obtained is believed to be approximately the same for method A and for method B. However, for the generally non-linear stress-strain response common to carbon fibres, the mean modulus values from these two methods will be somewhat different and not necessarily statistically comparable. Method B, or other methods, may be used in the purchase specification or for quality assurance by agreement between customer and supplier.

6 Apparatus and materials

6.1 Resin

The impregnating resin shall be compatible with the yarn and its size. The viscosity of the resin or resin solution shall be such that sufficient resin pick-up is achieved to ensure uniform impregnation. The strain at failure of the cured resin shall be at least twice that of the fibre, preferably three times. In this respect, heat-curable epoxy-resin systems with a viscosity during impregnation of preferably less than 1 000 mPa·s are suitable (see Annex A for example) as is any formulation capable of giving test specimens that fulfill the requirements of this International Standard. The resin formulation, however, shall be specified in detail and shall be agreed upon between the fibre manufacturer and the user.

6.2 Impregnation apparatus

Test specimens can be prepared by any method which produces a uniformly impregnated, smooth specimen.

These methods include both single- and multiple-specimen preparation techniques. A multiple-specimen impregnation apparatus may consist of:

6.2.1 A holder for the sample yarn bobbin, with yarn-tensioning devices.

6.2.2 An impregnation bath, with temperature-control devices and impregnation rollers or yarn-tensioning bars.

6.2.3 A unit to remove excess resin from the impregnated yarn by passing it over rollers covered with fabric, paper or felt and/or through a die.

6.2.4 A frame to wind up the impregnated yarn, preferably made of wood or metal coated with rubber.

Examples of impregnation apparatus are given in Annex B.

6.3 Curing oven with temperature control

A fan circulation oven is preferable to ensure uniform curing of the resin.

6.4 Tensile-testing machine

6.4.1 Use a tensile-testing machine with a constant crosshead speed, equipped with force- and extension-recording devices. The accuracy of the force indication shall be better than 1 % of the recorded value. The specimen-gripping system shall ensure that the test specimen is aligned with the axis of the test machine.

6.4.2 The tensile-testing machine shall include an extensometer linked to a continuous-recording device which automatically records the extension within the gauge length of the extensometer as a function of the force on the test specimen. The extensometer should be sufficiently light to induce only negligible stresses in the test specimen.

The gauge length of the extensometer shall be at least 50 mm but preferably 100 mm. The gauge length shall be determined with a tolerance of ± 1 %.

The extensometer shall have a tolerance on deviation from linearity of not more than 0,1 % over the required extension-measurement range.

Examples of suitable extensometers are given in Annex D. Other strain-measuring instruments, such as optical or laser instruments, may be used, if suitable.

6.5 Balance

Use a balance readable to 0,1 g to weigh the test specimens to determine the linear density of the impregnated yarn.

6.6 Ruler

Use a graduated ruler or other measuring device at least 500 mm long and accurate to ± 1 mm.

7 Test specimens

7.1 Number of test specimens

Prepare sufficient test specimens to enable four determinations to be made. If any of the specimens fails within the grips or at the tabs, or because of damage caused by the extensometer, discard the result and carry out a repeat determination on a fresh test specimen.

7.2 Length of test specimens

For test specimens with tabs, the length of the test specimen between the tabs shall be either (150 ± 5) mm or (200 ± 5) mm. For test specimens without tabs, the total length of the test specimen shall be (250 ± 5) mm or (300 ± 5) mm (at least the extensometer gauge length plus twice the grip length).

In cases of dispute, for test specimens with tabs, the length between the tabs shall be (150 ± 5) mm; for test specimens without tabs, the length of the test specimen shall be (250 ± 5) mm.

7.3 Impregnation of test specimens

7.3.1 The procedure for using the impregnation apparatus described in 6.2 is as follows:

7.3.2 Place the yarn bobbin on the holder.

7.3.3 Pour the impregnating-resin mixture into the resin bath (6.2.2) and adjust the temperature and viscosity to the desired values.

7.3.4 Draw the yarn through the resin bath and through the system designed to remove the excess resin while ensuring adequate resin impregnation (see 6.2.3).

7.3.5 Adjust the unwinding tension. The unwinding tension used shall be at the discretion of the individual test laboratory.

7.3.6 Wind the impregnated yarn onto the frame (6.2.4).

7.3.7 Place the frame in the oven (6.3).

7.3.8 Cure the resin in accordance with the resin manufacturer's instructions.

7.3.9 When the resin has been cured, remove the frame from the oven. After removal of the impregnated yarn from the frame, cut off a sufficient number of test specimens.

7.3.10 Select the test specimens according to the criteria given in 7.5.

7.4 Determination of other fibre properties

7.4.1 General

In order to make the calculations of tensile strength and tensile modulus given in Clause 10, the properties specified in 7.4.2 to 7.4.5 must be determined.

7.4.2 Linear density of the yarn

Determine the linear density of the yarn by the method given in ISO 1889.

7.4.3 Size content of the yarn

Determine the size content of the yarn by the method given in ISO 10548.

7.4.4 Density of the carbon fibre

Determine the density of the carbon fibre by one of the methods given in ISO 10119.

7.4.5 Linear density of impregnated-yarn test specimen

Measure the length of a test specimen (see 6.6), after it has been cut to length and prior to tabbing. Weigh the specimen (see 6.5).

Calculate the linear density of the impregnated yarn by dividing the mass of the test specimen by its length, expressing the result in grams per kilometre (tex).

NOTE It is not necessary to determine the linear density of the impregnated yarn for each specimen.

7.5 Criteria for selection of test specimens

7.5.1 Each test specimen shall be confirmed as straight when checked using a suitable jig. It shall be uniform in appearance and without any of the following defects:

- broken filaments;
- resin droplets;
- fibre misalignment.

7.5.2 The resin content shall be at least 30 % by mass. The resin content of the specimens can be calculated from the linear density of the test specimen and the linear density of the yarn from the equation:

$$\text{Resin content (\%)} = \frac{T_{\text{ti}} - T_{\text{tf}}}{T_{\text{ti}}} \times 100 \quad (1)$$

where

T_{ti} is the linear density of the test specimen, in tex;

T_{tf} is the linear density of the yarn, in tex.

For each preparation batch, a control sample of each yarn type being tested shall be verified for correct resin content. If the resin content of the control sample is outside the acceptable range, each set of specimens from that batch shall be verified for correct resin content.

7.5.3 The yarn shall be uniformly impregnated.

7.6 Preparation of test specimens with tabs

If a test specimen fails within the grips of the tensile-testing machine, the result is not valid. Affixing tabs to the test specimen may help to reduce the frequency of such failures. They may also help to assure correct alignment of the test specimen in the grips.

Specimens can be tested with or without tabs.

If tabs are necessary, the equipment required depends on the type of tab chosen. In all cases where tabs are used, the gripped length shall be at least 30 mm. See Annex C.

8 Atmosphere for conditioning and testing

The atmosphere used for conditioning and testing shall be selected from those defined in ISO 291.

9 Procedure for tensile testing

9.1 Set the cross-head speed of the tensile-testing machine (see 6.4.1). The maximum recommended speed is 250 mm/min. The maximum practical speed may be limited by the speed of the data-sampling or recording equipment.

9.2 For test specimens with tabs, install grips which fit the type of tab used. Adjust the distance between the grips to the prescribed specimen length (see 7.2).

For test specimens without tabs, install grips which are equipped with flat faces made of sheet materials of moderate elasticity and high coefficient of friction, such as hard rubber sheet. The sheet can be bonded onto the metal face of the grips with a suitable adhesive. If test specimens are found to slip within the grips during the test, it has been found useful to insert abrasive paper between the test specimen and the faces of the grips.

Because the test specimens are so fragile, it is recommended that the grip system is actuated by compressed air.

9.3 Clamp a test specimen in the grips of the test machine.

9.4 Fix the extensometer (see 6.4.2) carefully on the test specimen.

9.5 Start the recording device and load the test specimen to failure.

9.6 If the test specimen fails within the grips or the tabs, or because of damage caused by the extensometer, discard the result and carry out a repeat test on a fresh test specimen.

10 Expression of results

10.1 Tensile strength

10.1.1 For each test specimen, calculate the tensile strength of the yarn from the following equation:

$$\sigma_f = \frac{F_f}{A_f} \quad (2)$$

where

σ_f is the tensile strength, in megapascals;

F_f is the maximum tensile force, in newtons;

A_f is the cross-sectional area of the yarn, in square millimetres, given by the equation:

$$A_f = \frac{T_{\text{ff}}}{\rho_f} \times 10^{-3} \quad (3)$$

T_{ff} being the linear density, in tex, of the yarn without size, calculated from the linear density determined in accordance with ISO 1889 and the size content determined in accordance with ISO 10548;

ρ_f being the density of the yarn, in grams per cubic centimetre, determined in accordance with ISO 10119.

If the size content is sufficiently low for no error to be introduced, the linear density and density of the yarn with size may be used.

10.1.2 Calculate the arithmetic mean of the individual tensile-strength determinations and report as the result. If required in the product specification or by the person requesting the test, calculate the standard deviation and coefficient of variation of the individual determinations using normal statistical calculation methods.

10.2 Tensile modulus of elasticity (see Figure 1)

10.2.1 Method A

The tensile modulus of elasticity as determined by Method A is calculated from the following equation:

$$E_f = \frac{\Delta F}{A_f} \times \frac{L_0}{\Delta L} \times 10^{-3} \quad (4)$$

where

E_f is the tensile modulus of elasticity, in gigapascals;

ΔF is the variation in the force, in newtons, corresponding to the variation in the length, in millimetres, between the strain limits defined in Table 1;

A_f is the cross-sectional area of the yarn, in square millimetres [see Equation (3)];

L_0 is the gauge length of the extensometer, in millimetres;

ΔL is the variation in the length, in millimetres, corresponding to the variation in the force, resulting from the strain levels to be selected from Table 1.

Table 1 — Relationship between fibre type and strain limits

Strain at break ε typical of fibre type	Strain limits
$\varepsilon \geq 1,2 \%$	0,1 % to 0,6 %
$0,6 \% \leq \varepsilon < 1,2 \%$	0,1 % to 0,3 %
$0,3 \% \leq \varepsilon < 0,6 \%$	0,05 % to 0,15 %

NOTE The typical value of the strain at break (percent elongation at maximum load) may be determined by extensometry or calculated from typical strength and tensile-modulus values for the type of carbon fibre under test.

10.2.2 Method B

The tensile modulus of elasticity as determined by method B is calculated from the following equation:

$$E_f = \frac{\Delta F}{A_f} \times \frac{L_0}{\Delta L} \times 10^{-3} \quad (5)$$

where

E_f is the tensile modulus of elasticity, in gigapascals;

ΔF is the variation in the force, in newtons, corresponding to the variation in the length, in millimetres, between 400 mN/tex and 800 mN/tex;

A_f is the cross-sectional area of the yarn, in square millimetres [see Equation (3)];

L_0 is the gauge length of the extensometer, in millimetres;

ΔL is the variation in the length, in millimetres, corresponding to the variation in the force between 400 mN/tex and 800 mN/tex.

10.2.3 Calculate the arithmetic mean of the individual tensile-modulus determinations and report as the result. State in the test report whether method A, method B or another method was used.

If required in the product specification or by the person requesting the test, calculate the standard deviation and coefficient of variation of the individual determinations using normal statistical calculation methods.

10.3 Strain at maximum load (percent elongation at failure)

10.3.1 The strain at maximum load can be determined by extensometry or by calculation from the tensile strength and tensile modulus. It is a dimensionless quantity, expressed as a percentage.

10.3.2 The strain at maximum load ε_E as determined by extensometry is calculated from the following equation:

$$\varepsilon_E = \frac{L_u - L_0}{L_0} \times 100 \quad (6)$$

where

L_u is the gauge length of the extensometer at maximum load, in millimetres;

L_0 is the gauge length of the extensometer at zero load, in millimetres.

10.3.3 The strain at maximum load ε_C as determined by calculation from the tensile strength and tensile modulus is calculated from the following equation:

$$\varepsilon_C = \frac{\sigma_f}{E_f} \times 0,1 \quad (7)$$

where

σ_f is the tensile strength, in megapascals;

E_f is the tensile modulus of elasticity, in gigapascals (see 10.2).

10.3.4 Calculate the arithmetic mean of the individual strain determinations and report as the result. If required in the product specification or by the person requesting the test, calculate the standard deviation and coefficient of variation of the individual determinations using normal statistical calculation methods.

11 Precision

The precision of this test method is not known because inter-laboratory data are not available. Inter-laboratory data are being obtained and a precision statement will be added at the next revision.

12 Test report

The test report shall include the following:

- a) a reference to this International Standard;
- b) all details necessary for complete identification of the yarn tested;
- c) the linear density of the yarn;
- d) the density of the yarn;

- e) whether the extension to maximum load was calculated or determined experimentally;
- f) the number of test specimens tested, including the number discarded;
- g) the results obtained for the tensile strength, tensile modulus of elasticity and strain (percent elongation) at maximum load, and, if required, the individual results for each test specimen;
- h) the method of calculation of the tensile modulus of elasticity;
- i) any additional details which may have had a bearing on the results obtained.

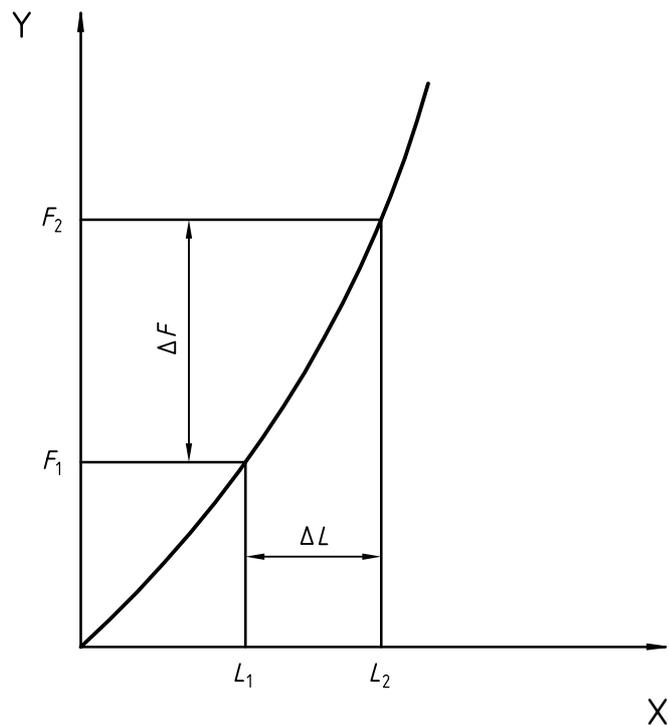

Key

- X extension (mm)
- Y force (N)

Figure 1 — Force-extension relationship during tensile testing

Annex A (informative)

Examples of heat-curable epoxy-resin systems

	Resin system	Amount	Cure conditions
1)	3,4-Epoxy-cyclohexyl 3,4-epoxycyclohexanecarboxylate (see Note 1) Boron trifluoride monoethylamine (BF ₃ MEA) 2-Propanone or ethanol	100 g 3 g 4 g	125 °C for 1 h or 130 °C for 30 min
2)	Diglycidyl ether bisphenol A (DGEBA) (see Note 2) with a viscosity of 11 000 mP·s to 14 000 mP·s at 25 °C and an epoxy equivalent of 184 g/equiv to 194 g/equiv Methyl nadic anhydrique (MNA) (see Note 3) Benzyl-dimethylamine 2-Propanone	100 g 90 g 1 g to 2 g 5 g	Room temperature for 10 h followed by 90 °C for 2 h and then 150 °C for 4 h or Room temperature for 10 h followed by 100 °C for 2 h and then 150 °C for 2 h
3)	Epoxy resin: same as in Example 2 Methyltetrahydrophthalic anhydride Benzyl-dimethylamine	100 g 90 g 3 g to 4 g	80 °C for 2 h followed by 200 °C for 1 h or 80 °C for 2 h followed by 150 °C for 4 h
4)	Epoxy resin: same as in Example 2 Dimethyl-diaminocyclohexylmethane Solvent	100 g 30 g Arbitrary	70 °C for 3 h or 80 °C for 2 h
5)	Epoxy resin: same as in Example 2 Bis(4-aminophenyl)sulfone Boron trifluoride monoethylamine (BF ₃ MEA) Solvent	100 g 20 g 1,5 g Arbitrary	80 °C for 1 h followed by 200 °C for 2 h
6)	Epoxy resin: same as in Example 2 Boron trifluoride monoethylamine (BF ₃ MEA) 2-Butanone	100 g 3 g 20 g	200 °C for 40 min

NOTE 1 The structure is as follows:

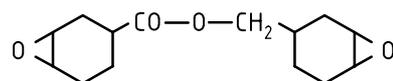

NOTE 2 The structure is as follows:

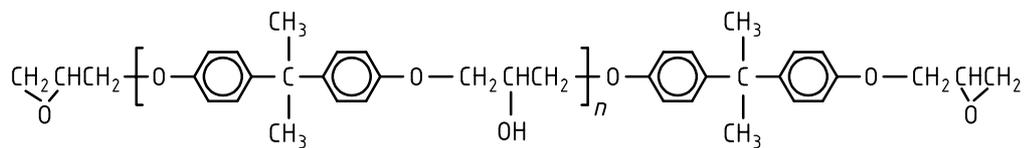

NOTE 3 Methyl-5-norbornene-2,3-dicarboxylic anhydride.

Annex B (informative)

Examples of impregnating apparatus

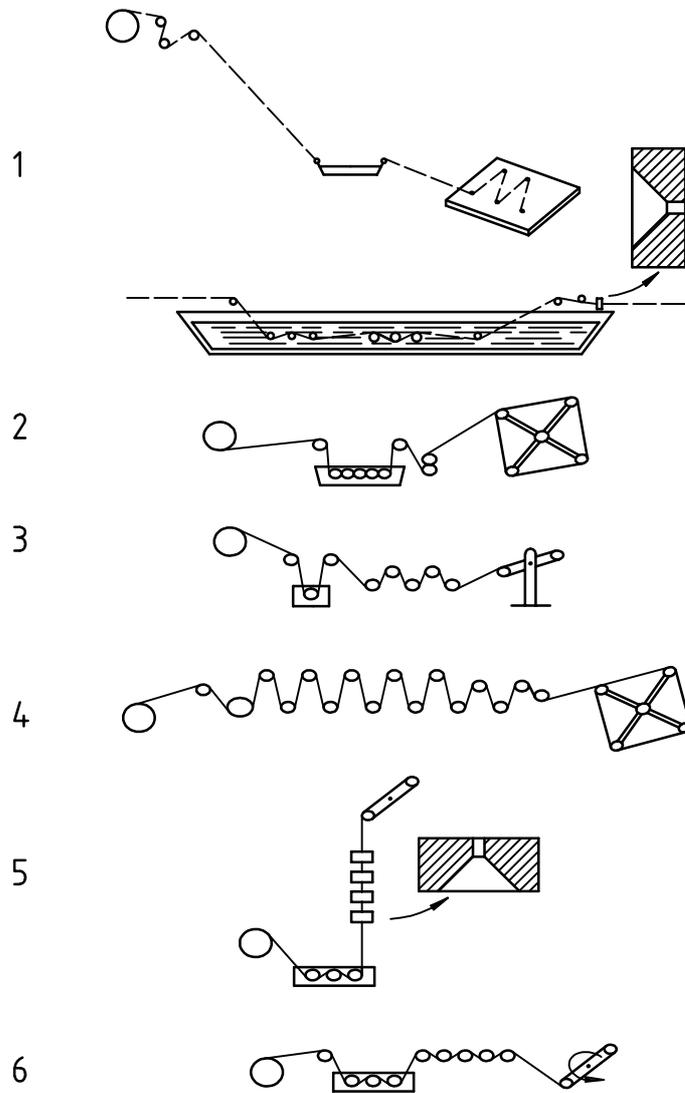

Annex C (informative)

Examples of tabs and tab-preparation apparatus

Various tabs and tabbing techniques are possible. Examples of possible materials are:

- cardboard;
- metal plates;
- resin-impregnated textile-glass fabrics;
- cast thermoset resins;
- thermoplastics.

Other materials may also be used.

When tab preparation is required, it is important that the method chosen gives acceptable, in particular straight, test specimens.

Dimensions in millimetres

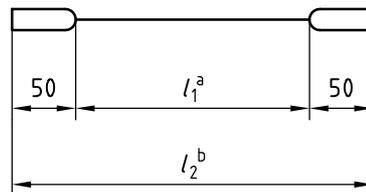

^a Variant 1: (150 ± 5) mm; variant 2: (200 ± 5) mm.

^b Variant 1: (250 ± 5) mm; variant 2: (300 ± 5) mm.

NOTE A mould to prepare the tabs is required.

Figure C.1 — Thermoplastic-resin tabs

Dimensions in millimetres

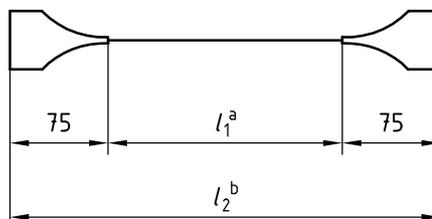

^a Variant 1: (150 ± 5) mm; variant 2: (200 ± 5) mm.

^b Variant 1: (300 ± 5) mm; variant 2: (350 ± 5) mm.

NOTE A mould to prepare the tabs is required.

Figure C.2 — Thermoset-resin tabs

Dimensions in millimetres

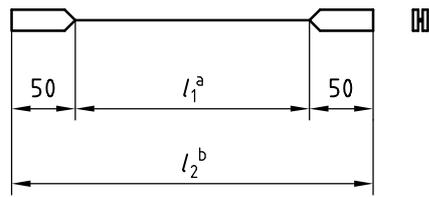

^a Variant 1: (150 ± 5) mm; variant 2: (200 ± 5) mm.

^b Variant 1: (250 ± 5) mm; variant 2: (300 ± 5) mm.

NOTE No special apparatus is required.

Figure C.3 — Cardboard tabs

Dimensions in millimetres

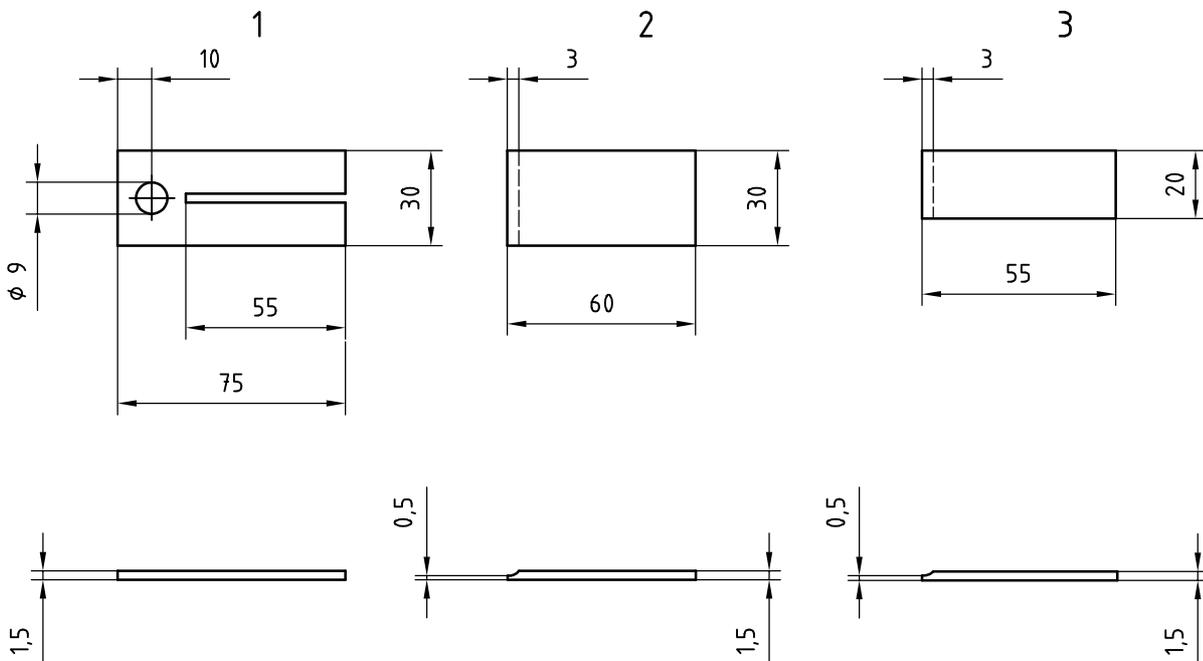
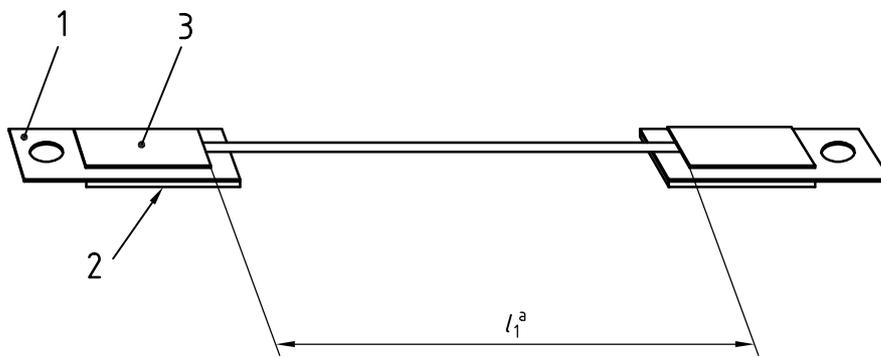

^a Variant 1: (150 ± 5) mm; variant 2: (200 ± 5) mm.

NOTE No special apparatus is required.

Figure C.4 — Metal-plate tabs

Annex D (informative)

Examples of extensometers

The test specimen is a thin resin-impregnated CFRP rod with a diameter in the range from about 0,3 mm (for 1 000-filament yarn) to about 1 mm (for 12 000-filament yarn).

Extensometers which are usually used on round or rectangular test specimens are hard to fix to resin-impregnated yarn specimens for the following reasons:

- a) the extensometer is too heavy to fix to such a small-diameter specimen;
- b) the knife edge of the extensometer and a spring or rubber band are difficult to fix tightly to such a small-diameter specimen.

The following types of extensometer are recommended:

- a) an automatic servo-controlled extensometer built into the tensile-testing machine;
- b) an extensometer which is mounted on the frame of the tensile-testing machine by means of a mounting bracket as shown in Figure D.1;
- c) an extensometer as shown in Figure D.2, which is built into a horizontal tensile-testing machine (one fixture is stationary while the other is moveable and is connected to one end of an optical displacement-measurement device which pivots on the frame).

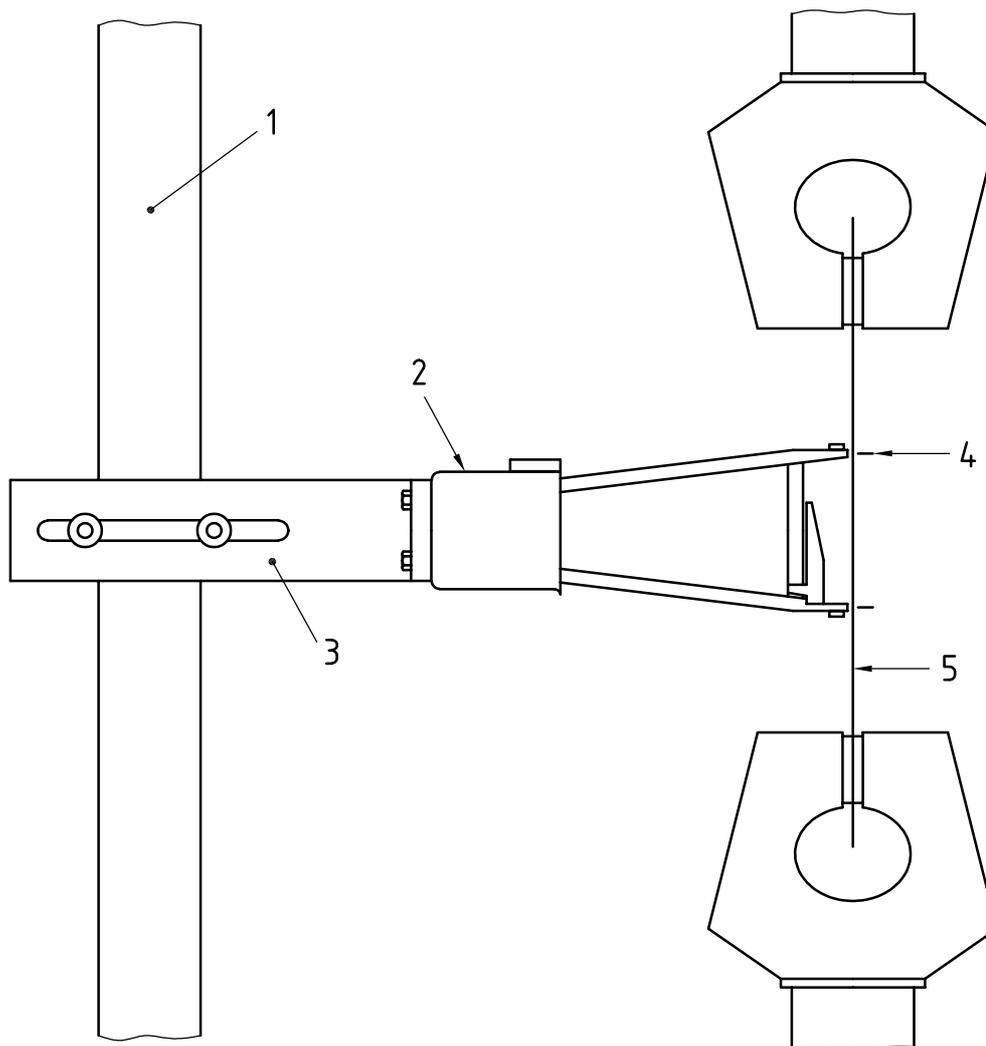

Key

- 1 frame of tensile-testing machine
- 2 extensometer
- 3 mounting bracket
- 4 spring or rubber band
- 5 test specimen

Figure D.1 — Extensometer mounted on frame of tensile-testing machine

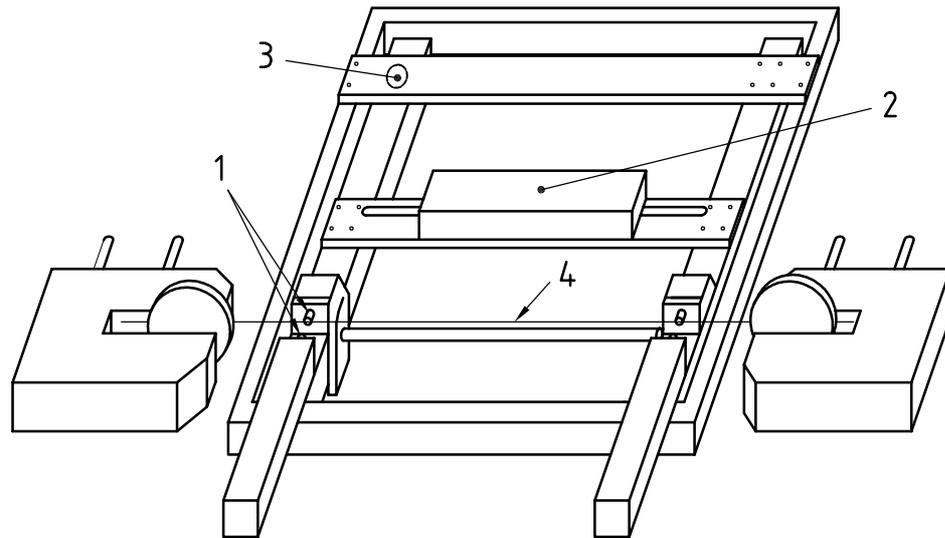

Key

- 1 extensometer knife edge
- 2 optical displacement-measurement device
- 3 pivot
- 4 test specimen

Figure D.2 — Extensometer connected to optical displacement-measurement device

Bureau of Indian Standards

BIS is a statutory institution established under the *Bureau of Indian Standards Act, 2016* to promote harmonious development of the activities of standardization, marking and quality certification of goods and attending to connected matters in the country.

Copyright

BIS has the copyright of all its publications. No part of these publications may be reproduced in any form without the prior permission in writing of BIS. This does not preclude the free use, in the course of implementing the standard, of necessary details, such as symbols and sizes, type or grade designations. Enquiries relating to copyright be addressed to the Head (Publication & Sales), BIS.

Review of Indian Standards

Amendments are issued to standards as the need arises on the basis of comments. Standards are also reviewed periodically; a standard along with amendments is reaffirmed when such review indicates that no changes are needed; if the review indicates that changes are needed, it is taken up for revision. Users of Indian Standards should ascertain that they are in possession of the latest amendments or edition by referring to the website-www.bis.gov.in or www.standardsbis.in.

This Indian Standard has been developed from Doc No.: TXD 40 (20314).

Amendments Issued Since Publication

Amend No.	Date of Issue	Text Affected

BUREAU OF INDIAN STANDARDS

Headquarters:

Manak Bhavan, 9 Bahadur Shah Zafar Marg, New Delhi 110002

Telephones: 2323 0131, 2323 3375, 2323 9402

Website: www.bis.gov.in

Regional Offices:

	Telephones
Central : 601/A, Konnectus Tower -1, 6 th Floor, DMRC Building, Bhavbhuti Marg, New Delhi 110002	{ 2323 7617
Eastern : 8 th Floor, Plot No 7/7 & 7/8, CP Block, Sector V, Salt Lake, Kolkata, West Bengal 700091	{ 2367 0012 2320 9474
Northern : Plot No. 4-A, Sector 27-B, Madhya Marg, Chandigarh 160019	{ 265 9930
Southern : C.I.T. Campus, IV Cross Road, Taramani, Chennai 600113	{ 2254 1442 2254 1216
Western : Plot No. E-9, Road No.-8, MIDC, Andheri (East), Mumbai 400093	{ 2821 8093

Branches : AHMEDABAD. BENGALURU. BHOPAL. BHUBANESHWAR. CHANDIGARH. CHENNAI. COIMBATORE. DEHRADUN. DELHI. FARIDABAD. GHAZIABAD. GUWAHATI. HIMACHAL PRADESH. HUBLI. HYDERABAD. JAIPUR. JAMMU & KASHMIR. JAMSHEDPUR. KOCHI. KOLKATA. LUCKNOW. MADURAI. MUMBAI. NAGPUR. NOIDA. PANIPAT. PATNA. PUNE. RAIPUR. RAJKOT. SURAT. VISAKHAPATNAM.