

सामग्री प्रबंधन के लिए पैलेट्स — फ्लैट
पैलेट्स — परीक्षण पद्धतियाँ
(तीसरा पुनरीक्षण)

Pallets for Materials Handling — Flat
Pallets — Test Methods
(Third Revision)

ICS 55.180.20

© BIS 2024

© ISO 2021



भारतीय मानक ब्यूरो
BUREAU OF INDIAN STANDARDS
मानक भवन, 9 बहादुर शाह ज़फर मार्ग, नई दिल्ली - 110002
MANAK BHAVAN, 9 BAHADUR SHAH ZAFAR MARG
NEW DELHI - 110002
www.bis.gov.in www.standardsbis.in

July 2024

Price Group 12

NATIONAL FOREWORD

This Indian Standard (Third Revision) which is identical to ISO 8611-1 : 2021 'Pallets for materials handling — Flat pallets — Part 1: Test methods' issued by International Organization for Standardization (ISO) was adopted by the Bureau of Indian Standards on the recommendations of Transport Packages, Packaging Codes and Pallets Sectional Committee and approval of the Transport Engineering Division Council.

This standard was first published in 1971 covering test code for non-expendable flat timber pallets only. First revision of this standard was made in 1977 incorporating bending strength test. In the first revision, the tests for metal pallets were also incorporated. The second revision of this standard was taken up to align it with ISO/DIS 8611 'General purpose flat pallets for through transit of goods — Test methods' issued by the International Organization for Standardization (ISO). ISO DIS 8611 later got published as ISO 8611 : 1991 and later was splitted into three parts by ISO TC 51 under the general title 'Pallets for materials handling — Flat pallets':

- a) ISO 8611-1:2021 Pallets for materials handling — Flat pallets — Part 1: Test methods;
- b) ISO 8611-2:2021 Pallets for materials handling — Flat pallets — Part 2: Performance requirements and selection of tests'; and
- c) ISO 8611-3:2011 Pallets for materials handling — Flat pallets — Part 3: Maximum working loads.

As Part 1 of ISO 8611 covers the test methods for pallets, in order to align Indian standard with latest international practices, IS 6219 is being revised by adopting ISO 8611-1 : 2021. The title of IS 6219 has also been aligned with ISO 8611-1 : 2021.

The text of ISO standard has been approved as suitable for publication as an Indian Standard without deviations. Certain terminologies and conventions are, however, not identical to those used in Indian Standards. Attention is particularly drawn to the following:

- a) Wherever the words 'International Standard' appear referring to this standard, they should be read as 'Indian Standard'; and
- b) Comma (,) has been used as a decimal marker, while in Indian Standards, the current practice is to use a point (.) as the decimal marker.

In this adopted standard, reference appears to certain International Standards for which Indian Standards also exist. The corresponding Indian Standards, which are to be substituted in their respective places, are listed below along with their degree of equivalence for the editions indicated:

<i>International Standard</i>	<i>Corresponding Indian Standard</i>	<i>Degree of Equivalence</i>
ISO 445 Pallets for materials handling — Vocabulary	IS 3971 : 2019/ISO 445 : 2013 Pallets for materials handling — Vocabulary (<i>third revision</i>)	Identical
ISO 2244 Packaging — Complete, filled transport packages and unit loads — Horizontal impact tests	IS 7028 (Part 3) : 2002/ISO 2244 : 2000 Performance tests for complete, filled transport packages: Part 3 Horizontal impact tests (horizontal or inclined test, pendulum test) (<i>second revision</i>)	Identical

(Continued on third cover)

Contents

Page

Introduction	v
1 Scope	1
2 Normative references	1
3 Terms and definitions	1
4 Measurements	3
5 Precision and accuracy of tests and apparatus	3
6 Test load	3
7 List of tests	4
8 Tests	4
8.1 Test 1 — Bending tests.....	4
8.1.1 Purpose.....	4
8.1.2 Procedure.....	5
8.1.3 Measurements.....	6
8.2 Test 2 — Forklifting tests.....	7
8.2.1 Purpose.....	7
8.2.2 Procedure.....	7
8.2.3 Measurement.....	8
8.3 Test 3 — Compression tests for blocks or stringers.....	9
8.3.1 Purpose.....	9
8.3.2 Procedure.....	9
8.3.3 Measurement.....	10
8.4 Test 4 — Stacking test.....	11
8.4.1 Purpose.....	11
8.4.2 Procedure.....	12
8.4.3 Measurement.....	12
8.5 Test 5 — Bottom deck bending tests.....	12
8.5.1 Purpose.....	12
8.5.2 Procedure.....	12
8.5.3 Measurement.....	13
8.6 Test 6 — Wing pallet bending tests.....	14
8.6.1 Purpose.....	14
8.6.2 Procedure.....	14
8.6.3 Measurements.....	15
8.7 Test 7 — Airbag bending tests.....	15
8.7.1 Purpose.....	15
8.7.2 Procedure.....	15
8.7.3 Measurement.....	18
8.8 Test 8 — Static shear test.....	18
8.8.1 Purpose.....	18
8.8.2 Procedure.....	18
8.8.3 Measurement.....	19
8.9 Test 9 — Corner drop test.....	19
8.9.1 Purpose.....	19
8.9.2 Procedure.....	19
8.9.3 Measurement.....	20
8.10 Test 10 — Shear impact tests.....	20
8.10.1 General.....	20
8.10.2 Purpose.....	21
8.10.3 Procedure.....	21
8.10.4 Measurement.....	21

8.11	Test 11 — Top deck edge impact test.....	22
	8.11.1 Purpose.....	22
	8.11.2 Procedure.....	22
	8.11.3 Measurement.....	23
8.12	Test 12 — Block impact test.....	24
	8.12.1 Purpose.....	24
	8.12.2 Procedure.....	24
	8.12.3 Measurement.....	25
8.13	Test 13 — Static coefficient of friction test.....	25
	8.13.1 Purpose.....	25
	8.13.2 Procedure.....	26
	8.13.3 Measurement.....	26
8.14	Test 14 — Slip angle test.....	26
	8.14.1 Purpose.....	26
	8.14.2 Procedure.....	26
	8.14.3 Measurement.....	27
9	Test report.....	27
	9.1 General information — All materials.....	27
	9.2 Information for wooden and wood-based composite pallets.....	28
	9.3 Information for plastics pallets.....	28
	9.4 Information for pallets made of other materials.....	28
	Bibliography.....	29

Introduction

The forces to which pallets are exposed during use vary significantly. The test procedures described in this document are approximate simulations of pallet use. These tests help the pallet designer to establish an initial acceptable balance between the cost and the performance of a pallet design. It is intended that all results of tests performed using this protocol be confirmed and verified using field trials before publication of performance or the commercial implementation of a new pallet design.

The nominal load, determined according to this test protocol, does not represent a payload and cannot be verified using field trials. The nominal load is a minimum payload level for use in determining maximum working load according to the procedures in ISO 8611-3. The maximum working load can be verified for a specified payload and intended use, using field trials. It is intended that the publication of the maximum working load include a description of the payload and the intended modes of use of the pallet.

It is essential to exercise care when comparing the results of tests with historic experience using existing pallet designs. User expectations of pallet performance vary. Some require greater and some accept lower levels of performance. Users are accepting different levels of risk when using pallets. Because of the varied performance expectations of pallet users, it is possible that the results of tests do not always reflect the user's perception of pallet performance in use.

It is possible that the nominal load does not reflect users' perception of pallet performance because the nominal load does not represent a payload. It is intended that maximum working loads be used to compare with the historic performance of existing pallet designs.

Regarding the use of the ISO 8611 series,

- this document describes the test methods;
- ISO 8611-2 describes the performance requirements and selection of tests;
- ISO 8611-3 describes tests for determining maximum working loads for known payloads.

This document and ISO 8611-2 are required for determining nominal load. The nominal load is the lowest safe load value for the specified support conditions, independent of the type of load (excluding concentrated loads).

This document, ISO 8611-2 and ISO 8611-3 are required for determining maximum working loads for known payloads.

The nominal load for the intended use is established by the selection of tests in this document; and the performance requirement is established from criteria in ISO 8611-2.

The following three types of intended use with specified support conditions are defined:

- handling of loaded pallets with racking and stacking;
- handling of loaded pallets without racking;
- handling of loaded pallets without racking or stacking.

To determine the maximum working load through testing given in ISO 8611-3, the deflection under the known payload cannot exceed the limiting deflection (see ISO 8611-3:2011, 4.2, 4.3 and 4.4) established in this document and ISO 8611-2. The maximum working load is the greatest payload that a pallet can be permitted to carry in a specific loading and support condition.

Guidance is given in ISO 8611-3:2011, Annex A as to the general effect on performance of different load types and stabilization methods. These can only give guidance as to the likely result from tests with the known payload.

Other tests for durability evaluation are specified in this document.

Indian Standard

**PALLETS FOR MATERIALS HANDLING — FLAT PALLETS —
TEST METHODS**

(Third Revision)

1 Scope

This document specifies the test methods available for evaluating new flat pallets for materials handling.

The test methods are split into groups for:

- nominal load testing;
- maximum working load testing;
- durability comparison testing.

This document does not apply to pallets with a fixed superstructure or a rigid, self-supporting container that can be mechanically attached to the pallet and which contributes to the strength of the pallet.

NOTE Specific tests for determining load capacity do not replace the value of conducting field tests on specific pallet designs.

2 Normative references

The following documents are referred to in the text in such a way that some or all of their content constitutes requirements of this document. For dated references, only the edition cited applies. For undated references, the latest edition of the referenced document (including any amendments) applies.

ISO 445, *Pallets for materials handling — Vocabulary*

ISO 2244, *Packaging — Complete, filled transport packages and unit loads — Horizontal impact tests*

ISO 8611-2:2021, *Pallets for materials handling — Flat pallets — Part 2: Performance requirements and selection of tests*

ISO 12777-1, *Methods of test for pallet joints — Part 1: Determination of bending resistance of pallet nails, other dowel-type fasteners and staples*

EN 13183-2, *Moisture content of a piece of sawn timber — Part 2: Estimation by electrical resistance method*

3 Terms and definitions

For the purposes of this document, the terms and definitions given in ISO 445 and the following apply.

ISO and IEC maintain terminology databases for use in standardization at the following addresses:

- ISO Online browsing platform: available at <https://www.iso.org/obp>
- IEC Electropedia: available at <https://www.electropedia.org/>

3.1
breaking of one component

fracture of a structural element which significantly affects the strength, *stiffness* (3.9) or functionality of a pallet

3.2
concentrated load

load concentrated over an area of less than 50 % of the pallet top deck

3.3
maximum working load

greatest *payload* (3.5) that a pallet is permitted to carry in a specific loading and support condition

Note 1 to entry: This varies according to the type, distribution, arrangement and means of stabilization of the load and the system of support, and can be lower or higher than the *nominal load* (3.4) (see ISO 8611-2 and ISO 8611-3).

3.4
nominal load

R
lowest *test load* (3.10) value for the specified support conditions, independent of the type of load (excluding *concentrated loads* (3.2))

Note 1 to entry: "Specified support conditions" refers to the range of conditions of use in ISO 8611-2:2021, 7.1.

Note 2 to entry: Nominal load does not represent an actual *payload* (3.5) on a pallet in use. The nominal load is used for comparing the performance of different pallets.

3.5
payload

Q
load carried by the pallet in use

Note 1 to entry: This can be above, identical to or below the *nominal load* (3.4).

3.6
platen

solid, rigid surface on a test machine used for applying a load to test a sample pallet

3.7
racking

storage of unit loads in drive-in or beam racks with free, unsupported spans

3.8
stacking

placing of pallets with unit loads one upon the other without recourse to intermediate shelves or *racking* (3.7)

3.9
stiffness

relative deformation of a pallet or component under load

Note 1 to entry: High stiffness means small displacement, deflection or deformation for a given load.

3.10
test load

P
load applicators, the load board or load box and the applied load itself including the datum load (1,5 % ± 0,5 % of the *ultimate load* (3.11))

3.11 ultimate load

U

load at which compression, displacement or deflection is no longer contained, resulting in the destruction of the specimen or *breaking of one component* (3.1), or when displacement, deformation or deflection becomes excessive

Note 1 to entry: See ISO 8611-2:2021, Table 1.

4 Measurements

Pallets selected for testing shall be measured to ensure that materials, construction and dimensions conform to their associated written specification.

The mass and the material of each pallet shall be determined and recorded at the time of testing.

The moisture content of wooden pallets shall be measured and recorded in accordance with EN 13183-2 at the time of testing.

The recorded deflection at each location in the test is the deflection at the end of the full test load period (or relaxation period) minus the deflection after positioning the datum load. The average of the maximum deflections recorded for each replicate shall be reported and used for further analysis.

[Clause 9](#) gives further details on what should be recorded during testing and in the written report.

5 Precision and accuracy of tests and apparatus

Test apparatus shall satisfy the following requirements.

- a) In the design of the test equipment, the tolerances on all dimensions shall be ± 2 %.
- b) The accuracy of measuring equipment for tests shall be $\pm 0,5$ mm.
- c) The accuracy of positioning of every component, excluding the test load, shall be ± 2 mm; measurement gauges shall be positioned to ± 4 mm.
- d) The accuracy of positioning of the centre of application of test load (where used) shall be ± 10 mm.
- e) The total mass of the test load applied shall be within ± 3 % of the prescribed value.

No part of any test rig shall distort an amount greater than ± 3 mm when under maximum test load. Distortion of the test rig shall be taken into account in measuring deflections of the pallet.

NOTE 1 Using heavy duty steel box sections in the construction of fixtures in tests 1 and 6 (see [Table 1](#)) normally results in central distortions approaching the 3 mm given limit.

The inclined plane apparatus shall be constructed as specified in ISO 2244 and shall permit inclined travel distance to change by 250 mm increments from 250 mm to 1 250 mm, each increment to within ± 5 mm.

NOTE 2 Experience suggests that the interlaboratory test precision for conducting tests 1a and 7a is 16,7 %; and 19,8 % when conducting tests 1b and 7b.

6 Test load

A general value for the test load is not fixed. The test load for each test shall be determined in accordance with ISO 8611-2.

The test load shall be applied with a testing machine, hydraulic or air pressure, or with dead load and shall increase continuously or in steps to the failure (for determination of ultimate load) or up to the fixed value (for qualification tests).

7 List of tests

[Table 1](#) provides a matrix of the tests (in this document) that shall be performed on flat pallets. Tests numbered 1, 2, 3, 4, 5, 6 and 7 shall be performed with new pallets. Tests 1, 2, 4, 5, 6 and 7 may be carried out on one test sample (first stiffness, then strength, when there is a declared nominal load) or on two separate samples.

NOTE 1 The tests are grouped into the three sections shown in [Table 1](#). The selection of tests and evaluation of pallet performance are set out in ISO 8611-2 and ISO 8611-3.

8 Tests

8.1 Test 1 — Bending tests

8.1.1 Purpose

The purpose of these tests is to determine the bending strength (test 1a) and bending stiffness (test 1b) of the pallet in racking situations.

Table 1 — List of tests

Test no.	Test measurement	Characteristic	Handling activity or purpose of the test	(Sub)clause ref.
Nominal load tests				8
1	Bending tests	Pallet length, width	Racking	8.1
1a	Bending strength			8.1.3.1
1b	Bending stiffness			8.1.3.2
2	Forklifting tests	Top deck	Lifting with forklift and pallet trucks	8.2
2a	Bending strength			8.2.3.1
2b	Bending stiffness			8.2.3.2
3	Compression tests for blocks or stringers	Height of blocks, stringers	Any activity that compresses blocks or stringers, including stacking	8.3
3a	Block or stringer strength			8.3.3.1
3b	Block or stringer stiffness			8.3.3.2
4	Stacking tests	Top and bottom deck	Stacking	8.4
4a	Deck strength test			8.4.3.1
4b	Deck stiffness test			8.4.3.2
5	Bottom deck bending tests	Bottom deck	Twin track conveyors and narrow span beam racking	8.5
5a	Bending strength			8.5.3.1
5b	Bending stiffness			8.5.3.2
6	Wing pallet bending tests	Pallet length, width	Lifting with slings	8.6
6a	Bending strength			8.6.3.1
6b	Bending stiffness			8.6.3.2
Maximum working load tests — With payload or airbag				
1	Bending test	Pallet length, width	Racking	8.1
1b	Bending stiffness			8.1.3.2

Table 1 (continued)

Test no.	Test measurement	Characteristic	Handling activity or purpose of the test	(Sub)clause ref.
7	Airbag bending tests	Pallet length, width	Racking	8.7
7a	Bending strength			8.7.3.1
7b	Bending stiffness			8.7.3.2
2	Forklifting tests	Top deck	Lifting with forklift and pallet trucks	8.2
2b	Bending stiffness			8.2.3.2
4	Stacking tests	Top and bottom deck	Stacking	8.4
4b	Deck stiffness test			8.4.3.2
5	Bottom deck bending tests	Bottom deck	Twin track conveyors and narrow span beam racking	8.5
5b	Bending stiffness			8.5.3.2
6	Wing pallet bending tests	Pallet length, width	Lifting with slings	8.6
6b	Bending stiffness			8.6.3.2
Durability tests				
8	Static shear test	Decks, blocks, stringers	Distortion resistance	8.8
9	Corner drop test	Diagonal rigidity	Resistance to impacts	8.9
10	Shear impact test	Decks, blocks, stringers	Distortion resistance	8.10
11	Top deck edge impact test	Top leading deckboard	Resistance to fork arms	8.11
12	Block impact test	Corner block, stringer	Resistance to fork tip	8.12
13	Static coefficient of friction test	Under deck/fork arms	Slip resistance on fork arms	8.13
14	Slip angle test	Top deck/payload	Slip resistance of loads	8.14

8.1.2 Procedure

8.1.2.1 In order to establish the weakest pallet support dimension, test one pallet across the length of the pallet and then a second pallet across the width of the pallet. There is no requirement for further tests on the stronger dimension unless the result is within 15 % of the weaker.

8.1.2.2 This having been established, place a fresh pallet across its weakest side, top deck uppermost, on pallet supports positioned with their inside edges 75 mm from the outer edges of the pallet. The load applicators shall be positioned at 0,18 L_1 or 0,18 L_2 , where measured as shown, where L_1 or L_2 is the distance between the pallet supports (see [Figure 1](#)).

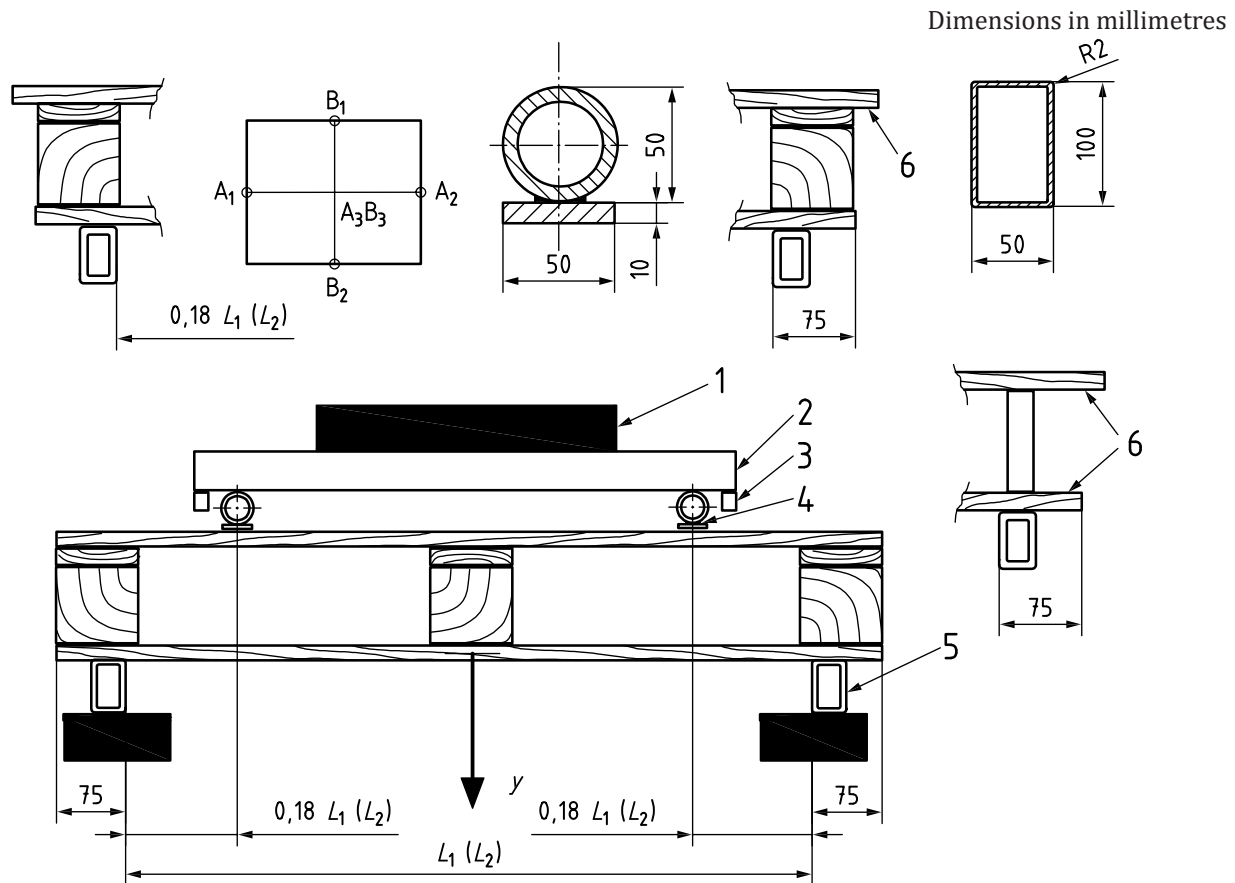

Key

- | | |
|-------------------|--------------|
| 1 test load | 5 support |
| 2 load board | 6 wing |
| 3 safety stop | y deflection |
| 4 load applicator | |

Figure 1 — Bending test

8.1.2.3 Load applicators and supports shall be flush with or project beyond the edges of the pallet. Edges shall be relieved with (2 ± 1) mm radii. Where load applicators coincide with gaps between deckboards, in-fill pieces of equal thickness to deckboards with 3 mm to 6 mm overall clearance on each shall be used. Place on the pallet deck, the load applicators and the load board, then apply the rest of the test load.

8.1.3 Measurements

8.1.3.1 Test 1a — Determination of bending strength

Place a load on the load board until breakage of one of the components of the pallet or until reaching an excessive deflection or deformation. Record the ultimate load and choose the minimum load among 3 replicates.

8.1.3.2 Test 1b — Determination of bending stiffness

Apply a datum load of $(1,5 \pm 0,5)$ % of the ultimate load determined in test 1a. Depending on the support location, the deflection, y , shall be measured at points A [maximum of y at A_1 (B_1), A_2 (B_2), A_3 (B_3)]:

- a) after positioning of datum load;

- b) immediately after full test load is applied;
- c) at end of the full test load period;
- d) after the relaxation period.

8.2 Test 2 — Forklifting tests

8.2.1 Purpose

The limiting condition of use for non-rackable and non-stackable single or double-deck pallets is the bending of the pallet on fork arm supports under the top deck of the pallet.

8.2.2 Procedure

The forklifting test is shown schematically in [Figure 2](#). The test method permits simulation of the forklifting condition of use in each direction of pallet length and width. The supports shall conform to [Figure 2](#). The support distances may be either 570 mm or 690 mm (see [Figure 2](#), footnote a). The shorter of the two distances that occur during pallet use shall be used in the test. For pallets greater than 1 219 mm in length or width, footnote a of [Figure 2](#) may be adjusted according to the dimensions of the pallet.

Perform the test in both directions.

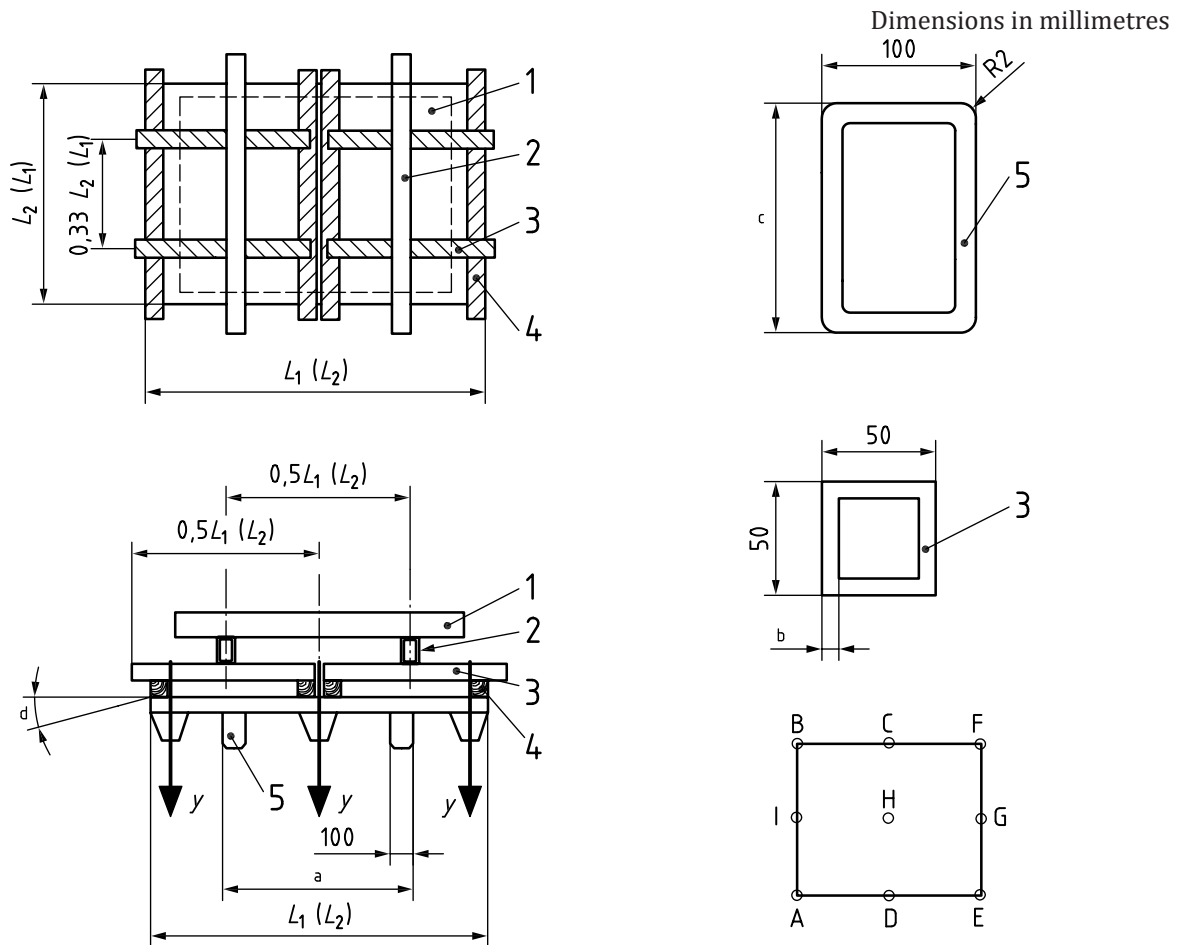

Key

- | | | | |
|--------|--|----------|---|
| 1 | test load | <i>y</i> | deflection |
| 2 | load applicator | <i>a</i> | The distance between the supports 570 mm or 690 mm. |
| 3 | steel load bar, 50 mm × 50 mm × $L \left[\frac{W L_1}{2} \right]$ | <i>b</i> | Steel load bar thickness 2 mm. |
| 4 | steel load bar, 50 mm × 50 mm × $L [W L_1]$ | <i>c</i> | Support length 200 mm. |
| 5 | support | <i>d</i> | Bend angle of pallet deck while testing. |
| A to I | deflection measuring points | | |

Figure 2 — Forklifting test

8.2.3 Measurement

8.2.3.1 Test 2a — Determination of bending strength

Apply the test load until breakage occurs in one of the components of the pallet or until reaching an excessive deflection or deformation. Record the ultimate load and choose the minimum load among 3 replicates.

8.2.3.2 Test 2b — Determination of bending stiffness

Apply a datum load of $(1,5 \pm 0,5)$ % of the ultimate load determined in test 2a. Depending on the support location, the deflection, y , shall be measured simultaneously at the middle of the two ends or sides and at the corners (maximum value of y at points A, B, C, D, E, F, G, H, I, depending on direction of supports):

- a) after positioning of datum load;
- b) immediately after full test load is applied;
- c) at end of the full load period;
- d) after the relaxation period.

8.3 Test 3 — Compression tests for blocks or stringers

8.3.1 Purpose

The purpose of this test is to determine the compression strength (test 3a) and stiffness (test 3b) of the blocks, stringers or columns of the pallet. Blocks or stringers supporting superstructures or heavy rigid loads shall be tested.

8.3.2 Procedure

Place the pallet in a normal position on a flat, hard, rigid and horizontal surface. Place a rigid load applicator of dimensions (300 ± 5) mm \times (300 ± 5) mm \times (25 ± 5) mm, over a block or a portion of a stringer (as shown in [Figure 3](#)).

Place the test load centrally on to the load applicator, as shown by the arrows in [Figures 3](#) a), b) and c). When the blocks or stringers differ in design, each design shall be tested.

Alternatively, the test may be carried out on several identical corners, blocks or stringers.

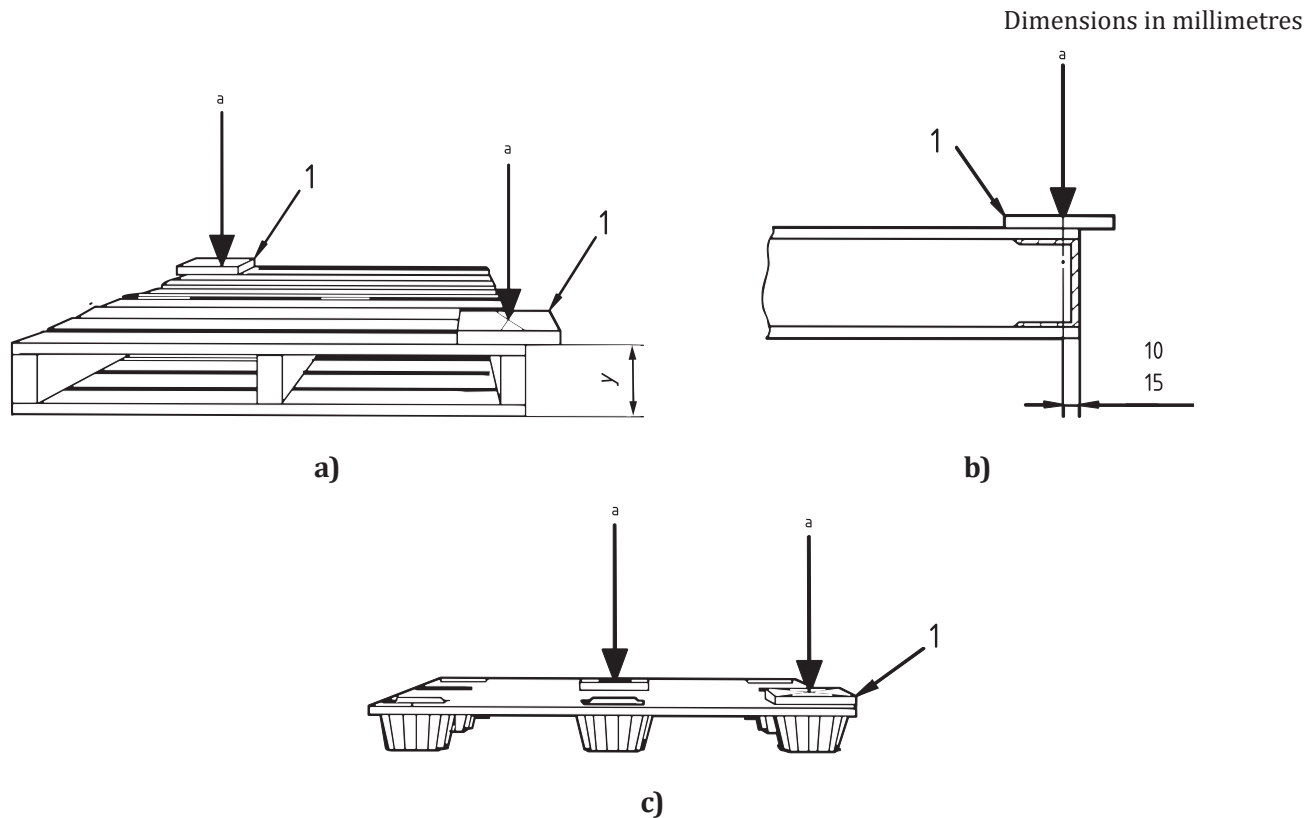

Key

- 1 load applicator
- y deflection
- a Test load.

Figure 3 — Corner compression test

8.3.3 Measurement

8.3.3.1 Test 3a — Determination of strength of blocks or stringers

Apply the load until breakage occurs in one of the blocks or stringers of the pallet or upon reaching an excessive deflection or deformation. Record the ultimate load and choose the minimum load among 3 replicates.

8.3.3.2 Test 3b — Determination of stiffness of blocks or stringers

Apply a datum load of $(1,5 \pm 0,5) \%$ of the ultimate load determined in test 3a.

The deflection, y , shall be measured:

- a) after positioning of datum load;
- b) immediately after the full test load is applied;
- c) at end of the full test load period;
- d) after the relaxation period.

8.4 Test 4 — Stacking test

8.4.1 Purpose

The purpose of this test is to determine the ability of the pallet top and bottom decks to withstand the local effects of widely varying payloads on subspans of decks between blocks or stringers in a block stacking situation. For pallets with more than two spans (openings), the load applicators shall be applied to the two openings of greatest span as shown in [Figure 4](#). Where a single span is the largest, the test is not applicable.

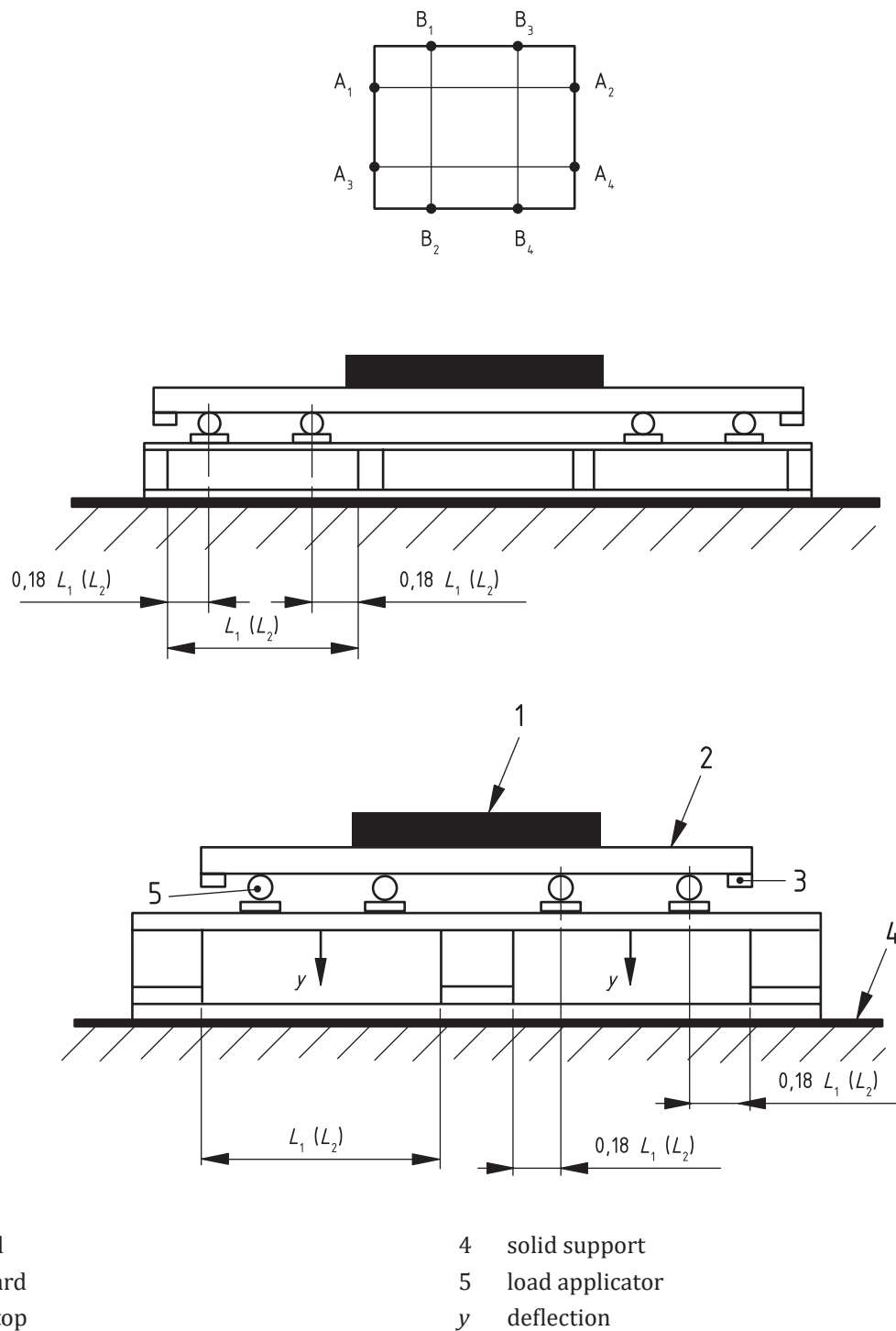

Figure 4 — Deck strength and stiffness test

8.4.2 Procedure

Test both the top and bottom decks.

Place the pallet, as shown in [Figure 4](#), on a flat, hard, rigid horizontal surface and place four applicators, as described in [8.1.2](#) and [Figure 1](#), across the top or bottom boards so that the centres of the load applicators are at $0,18 L_1$ or $0,18 L_2$. The load applicators shall project over or be flush with the edge of the pallet deck and shall be symmetrically placed about the centre line of the pallet.

8.4.3 Measurement

8.4.3.1 Test 4a — Deck strength test

Apply the test equipment and then the rest of the test load. If dead weight is used for the test load, it shall be symmetrically built up during loading. If the pallet has bottom boards in both directions the test shall be carried out in both the length and the width dimensions.

Place a load on the load board until breakage occurs or until reaching an excessive deflection or deformation. Record the ultimate load and choose the minimum load among 3 replicates.

Record the deflections at half ultimate load.

Depending on the orientation of the load applicators, the deflection, y , shall be measured at points A (maximum of y at A_1, A_2, A_3, A_4) or B (maximum of y at B_1, B_2, B_3, B_4).

8.4.3.2 Test 4b — Deck stiffness test

Support the bottom pallet on a solid surface. Apply a datum load of $(1,5 \pm 0,5)$ % of the ultimate load determined in test 4a. The deflection, y , shall be measured at points A (maximum of y at A_1, A_2, A_3, A_4) or B (maximum of y at B_1, B_2, B_3, B_4), depending on pallet design and orientation of load applicators.

Measure the maximum local deflection, y :

- a) after positioning the datum load;
- b) immediately after the full test load is applied;
- c) at the end of the full load period;
- d) after the relaxation period.

8.5 Test 5 — Bottom deck bending tests

8.5.1 Purpose

The purpose of these tests is to determine the strength and stiffness of the bottom deck between blocks or stringers when handling on twin track conveyors or narrow span beam rack supports.

8.5.2 Procedure

Place the top deck downwards, as shown in [Figure 5](#), on a flat, hard, rigid horizontal surface and place two inverted applicators, as described in [8.1.2](#) and [Figure 1](#), across the bottom boards so that the centres of the load applicators are at a distance of $0,25 L_1$ or $0,25 L_2$ from the inside edge of the outer blocks or stringers. The load applicators shall project over or be flush with the edge of the pallet base and shall be symmetrically placed about the centre line of the pallet.

Apply the test equipment and then the rest of the test load. If dead weight is used for the test load, it shall be symmetrically built up during loading. If the pallet has bottom boards in both directions, the test shall be carried out in both the length and the width dimensions.

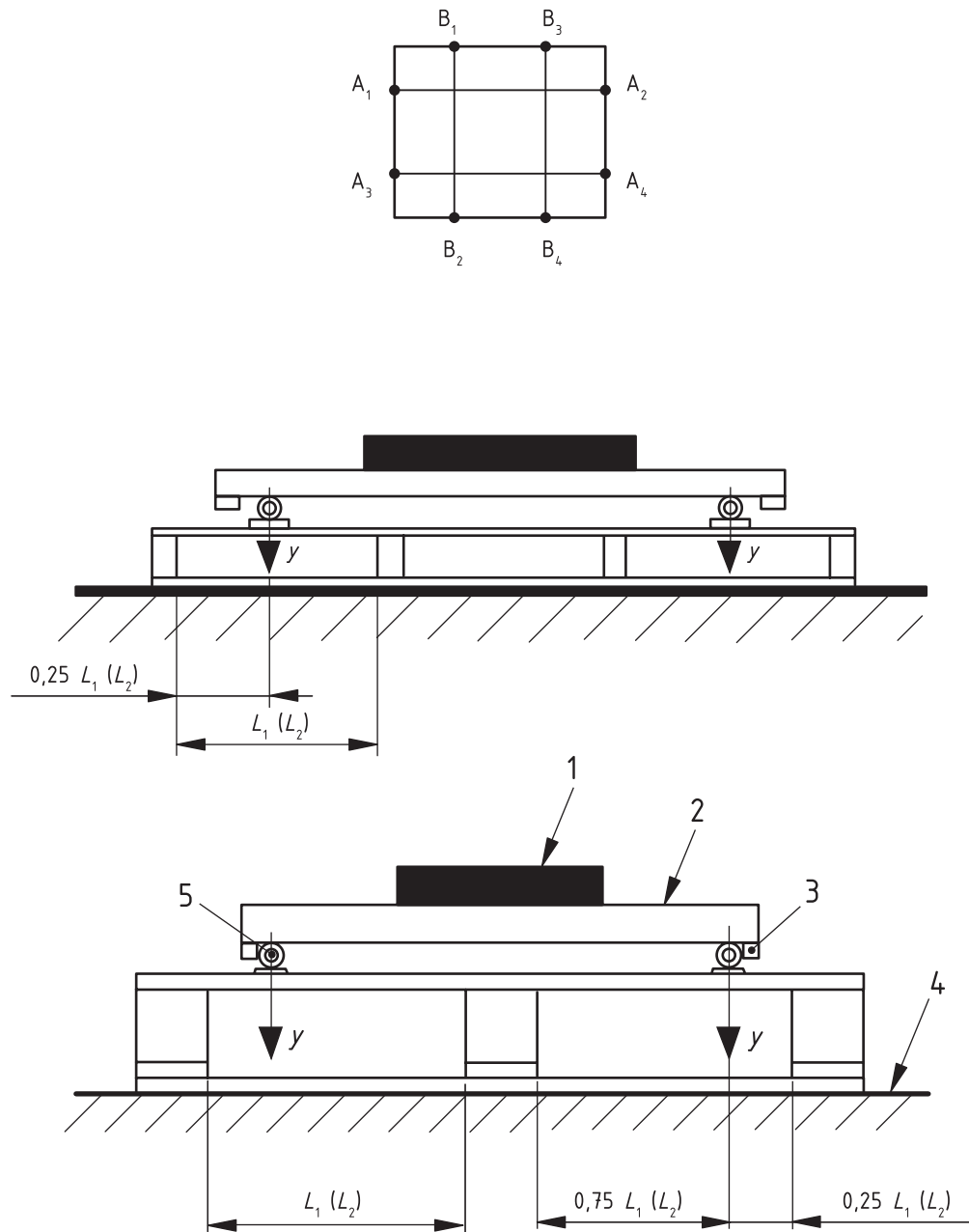

Key

- | | | | |
|---|-------------|---|-----------------|
| 1 | test load | 4 | solid support |
| 2 | load board | 5 | load applicator |
| 3 | safety stop | y | deflection |

Figure 5 — Bottom deck strength and stiffness test

8.5.3 Measurement

8.5.3.1 Test 5a — Determination of bending strength

Place a load on the load board until breakage in one of the bottom boards occurs or until reaching an excessive deflection or deformation. Record the ultimate load and choose the minimum load among 3 replicates.

8.5.3.2 Test 5b — Determination of bending stiffness

Apply a datum load of $(1,5 \pm 0,5)$ % of the ultimate load determined in test 5a. Depending on the orientation of the load applicators, the deflection, y , shall be measured at points A (maximum of y at A_1, A_2, A_3, A_4) or B (maximum of y at B_1, B_2, B_3, B_4):

- a) after positioning of datum load;
- b) immediately after full test load is applied;
- c) at end of the full load period;
- d) after the relaxation period.

8.6 Test 6 — Wing pallet bending tests

8.6.1 Purpose

The purpose of these tests is to determine the bending strength (test 6a) and the bending stiffness (test 6b) of winged pallet during lifting with slings.

8.6.2 Procedure

Place the wing pallet, top deck uppermost, on four posts 50 mm × 50 mm positioned beneath the wings of the top deck flush with the ends of the pallet. The supports shall be fixed at such a height that a space of at least 50 mm is between the underside of the bottom deck and the ground or test frame. Each load applicator shall be positioned such that the dimension from the inside edge of the support to the centre line of the load applicators shall be $0,18 L_1$ as shown in Figure 6. Place the load board on the load applicators and then apply the rest of the test load.

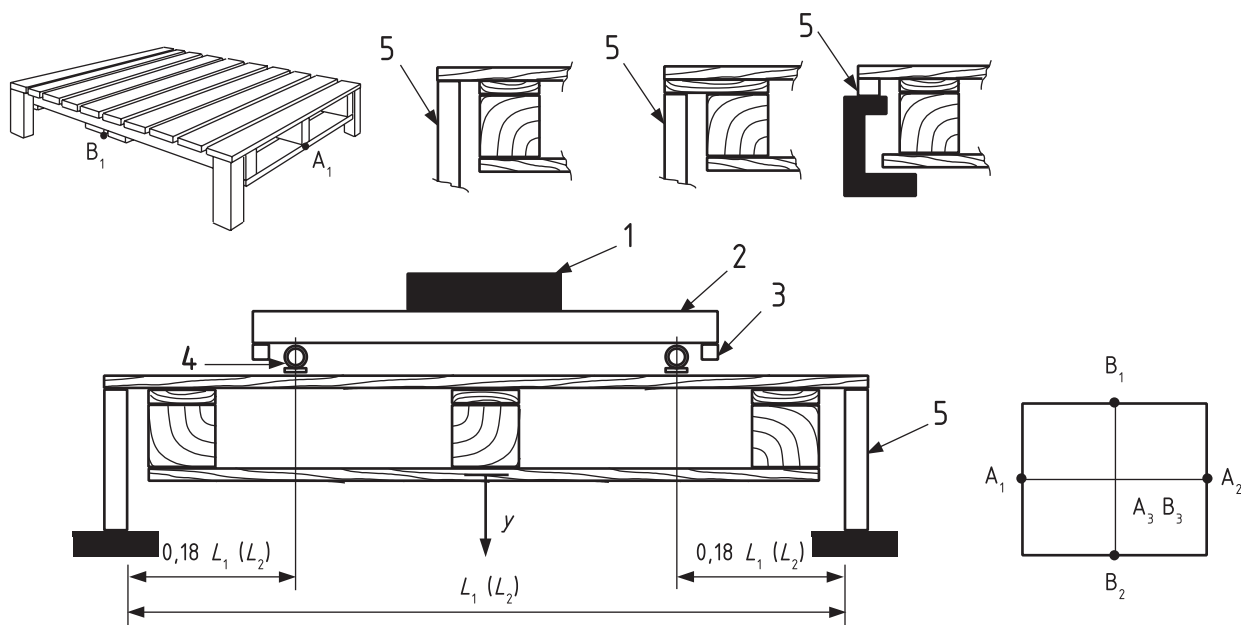

Key

- | | | | |
|---|-------------|-----|-----------------|
| 1 | test load | 4 | load applicator |
| 2 | load board | 5 | support |
| 3 | safety stop | y | deflection |

Figure 6 — Wing pallet bending test

8.6.3 Measurements

8.6.3.1 Test 6a — Determination of bending strength

Place a load on the load board until breakage of one of the components of the pallet or until reaching an excessive deflection or deformation. Record the ultimate load and choose the minimum load among 3 replicates.

8.6.3.2 Test 6b — Determination of bending stiffness

Apply a datum load of $(1,5 \pm 0,5)$ % of the ultimate load determined in test 6a. Depending on the support location, the deflection, y , shall be measured at points A [Maximum of y at A_1 (B_1) and A_2 (B_2)]:

- a) after positioning the datum load;
- b) immediately after the full test load is applied;
- c) at end of the full test load period;
- d) after the relaxation period.

8.7 Test 7 — Airbag bending tests

8.7.1 Purpose

The purpose of this form of bending test is to simulate, as near as is practically feasible, certain load applications as commonly encountered in the field. The load applicator used for this bending test is an analogue for common uniform flexible loads often supported by pallets, such as cased or bagged goods.

This uniform flexible load analogue is used when, under certain circumstances, the primary load applicators, as described in [8.1.2](#), cannot be used, or when the application of simulated uniform loads can aid the pallet designer in selecting the most appropriate pallet for a given use.

8.7.2 Procedure

8.7.2.1 In order to establish the weakest pallet support direction, test one pallet across the length of the pallet and then a second pallet across the width of the pallet. There is no requirement for further tests on the stronger dimension unless the result is within 15 % of the weaker dimension.

8.7.2.2 The load applicator shall be a medium or low-pressure envelope airbag, commonly called a “lifting” or “dunnage” bag, shown in [Figures 7](#) and [8](#). Airbags of this type are specified by size (length and width), containment (maximum working pressure) and stroke (maximum unrestricted expansion in bag height).

Dimensions in millimetres

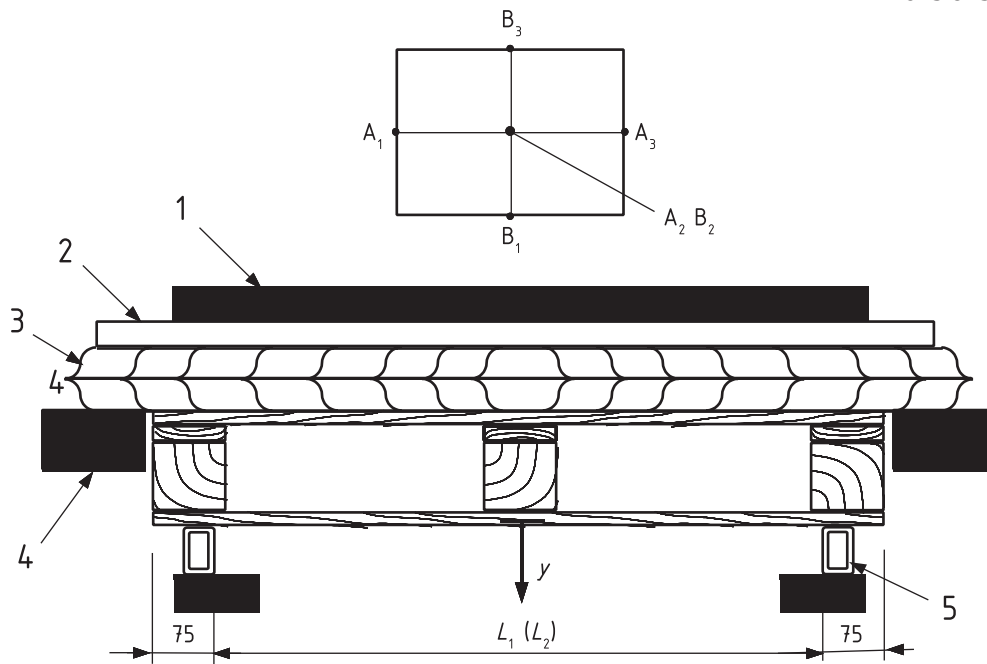

Key

- | | | | |
|---|-------------|----------|---------------------|
| 1 | dead weight | 4 | airbag support beam |
| 2 | load board | 5 | supports |
| 3 | airbag | <i>y</i> | deflection |

Figure 7 — Airbag bending tests using dead weight

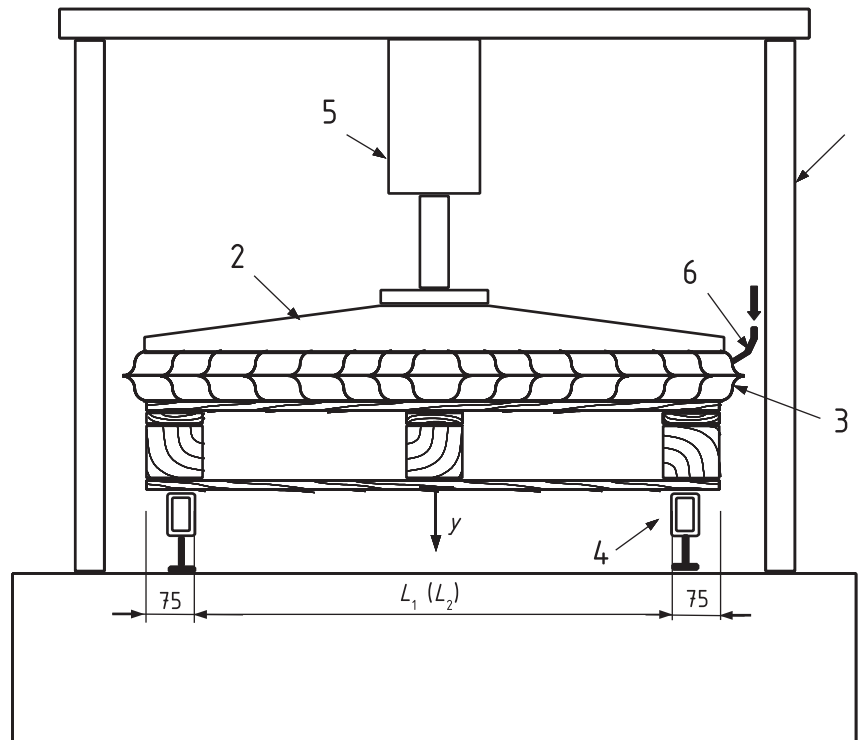

Key

- | | |
|------------------|---------------------|
| 1 test rig frame | 5 load applicator |
| 2 load platen | 6 inflation tube |
| 3 airbag | <i>y</i> deflection |
| 4 supports | |

Figure 8 — Airbag bending tests using test rig

8.7.2.3 The size of a bag shall be such that, when inflated, the bag is in contact with the entire deck of the pallet. This is often possible with bags approximately 150 mm longer and wider than the top deck of the pallet to be tested.

8.7.2.4 Where bag sides overhang the pallet by more than 75 mm on either edge or end, an airbag support beam is necessary to maintain the bag overhang at the same level as the upper pallet deck during testing.

Where the load applied to the pallet is measured above the pallet during the test, the supports shown in [Figure 8](#) shall not be used and the bag should fit the pallet as described in [8.7.2.3](#).

8.7.2.5 The containment or working pressure in the bag shall be adequate to structurally fail all pallets to be tested. Experience indicates that the working pressure shall be at least 0,07 MPa to 0,08 MPa.

8.7.2.6 The stroke or level of expansion in bag height depends on the design of the testing apparatus. Where expansion varies along the centre or edges of the bag, the region of least expansion shall govern bag selection. In order to avoid the influence of bag stiffness on the test data, the bag expansion shall be at least twice that necessary to cause pallet failure. The pallet supports shall be positioned as described in [Figure 1](#) and shall be positioned with their centre lines 75 mm from the outer edges of the pallet.

8.7.2.7 Loading or testing rates shall be controlled by appropriately inflating the restrained airbag or by pressing the inflated airbag on to the upper pallet deck.

8.7.3 Measurement

8.7.3.1 Test 7a — Determination of bending strength

Increase the load until breakage occurs in one of the components of the pallet or until reaching an excessive deflection or deformation. Record the ultimate load and choose the minimum load among 3 replicates.

8.7.3.2 Test 7b — Determination of bending stiffness

Apply a datum load of $(1,5 \pm 0,5)$ % of the ultimate load determined in test 7a. Depending on the support location, the deflection, y , shall be measured at points A (maximum of y at A_1, A_2, A_3) or B (maximum of y at B_1, B_2, B_3):

- a) after positioning of datum load;
- b) immediately after the full test load is applied;
- c) at end of the full load period;
- d) after the relaxation period.

8.8 Test 8 — Static shear test

8.8.1 Purpose

The purpose of this test is to simulate the approximate forces induced through lateral deck shear.

8.8.2 Procedure

Place the pallet vertically, top deck on the test frame, on a vertically positioned board with the same thickness as the deck boards. The length of the board shall be at least equal to the length or width of the tested pallet (see [Figure 9](#)). The load applicator at C touches the entire pallet length (or width) along the bottom deck. An alternative test method is to apply the same line load using a compression tester at point C; however, whenever this method is used, then the loading point C platen shall be restrained from movement in any plane other than vertical with $L_2 > 150$ mm.

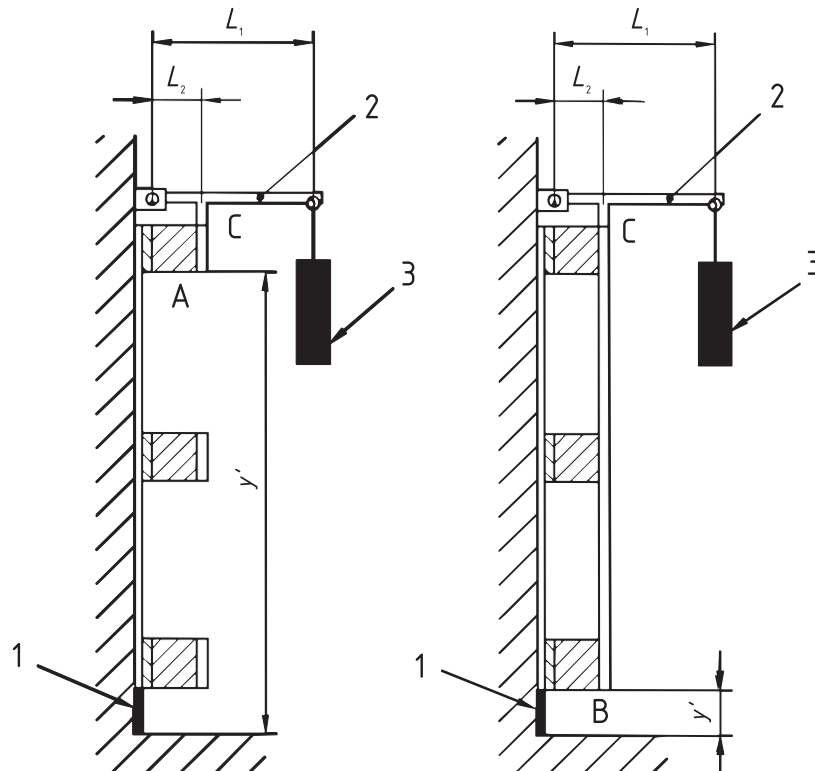

Key

- 1 support
- 2 load applicator
- 3 load W
- y' deflection
- A to C distortion measurement points

Figure 9 — Static shear test

8.8.3 Measurement

The applied test load at C, F , resulting from the application of load, W , gives rise to the vertical distortion which shall be measured at A or B, depending upon whether the pallet has a continuous bottom board. Distortion (change in y') shall be measured after release of load and after a relaxation period.

$$F = \frac{L_1 \cdot W}{L_2}$$

8.9 Test 9 — Corner drop test

8.9.1 Purpose

The purpose of this test is to determine the diagonal rigidity of the top deck of the pallet and its resistance to impact.

8.9.2 Procedure

Mark the two measuring points, A and B, as shown in [Figure 10](#) at approximately 50 mm from the corners of the pallet. While suspending the pallet as shown in [Figure 10](#), drop the pallet freely on to its

top deck corner edge from a height, h , on to a hard horizontal impact surface. Whenever possible, carry out the drop three times, always on the same corner and from the same height.

NOTE For asymmetric pallets, it is necessary for the tester to make a judgement as to the orientation of the pallet before dropping.

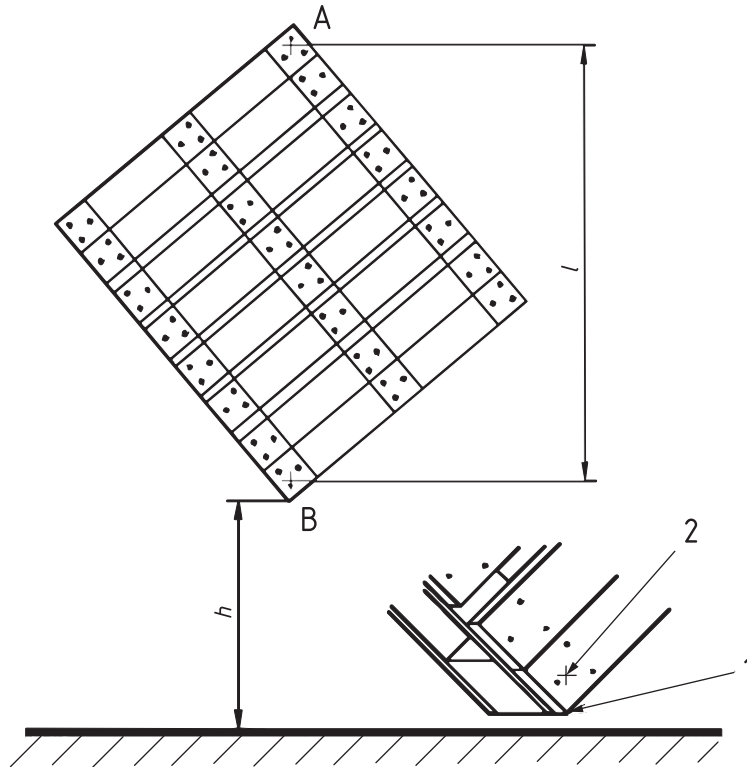

Key

- 1 pallet corner
- 2 measuring point
- h height (fall)
- l length of diagonal

Figure 10 — Corner drop test

8.9.3 Measurement

The length of diagonal, l , shall be measured before the first and after the third drop. Any damage shall be noted.

8.10 Test 10 — Shear impact tests

8.10.1 General

The test load comprises the dead load, a load-spreading sheet and a load box, having a plan size of $(600 \pm 50) \text{ mm} \times (800 \pm 50) \text{ mm}$. Place the load within the box, which shall be placed in a position dependent upon the individual test requirements described in [8.10.3](#) and [8.10.4](#). The detachable supporting edges shall be at least as long as the pallet deck under test. The test load shall not include the mass of the dolly.

For each of the inclined plane tests, before release the dolly is raised a distance, L , up the incline from the point of impact.

Inclined plane tests are potentially hazardous in view of large masses travelling at high speeds. The design of such test rigs shall incorporate special safety features to reduce risks to both operators and observers.

8.10.2 Purpose

The purpose of this test is to determine the resistance to side horizontal impacts of the assembly between the top deck, blocks, stringers, stringer boards and bottom deck.

8.10.3 Procedure

Secure a steel or high-density hardwood beam, (90 ± 10) mm \times (90 ± 10) mm in nominal cross-section and at least as long as the longer dimension of the pallet, to the face of the backstop. The upper edge of the barrier shall be 15 mm above the bottom surface of the pallet (top surface of the dolly) whenever the dolly is in its lowest position (see [Figure 11](#)).

Place the pallet on the dolly of the inclined plane testing machine such that when the forward edge of the pallet is resting against the barrier, the dolly is $25 \text{ mm} \pm 5 \text{ mm}$ clear of it.

The test load is distributed over the pallet deck surface with the exception of the leading 100 mm (which are left exposed) by means of a load-spreading sheet. This may conveniently comprise a sheet of strong plywood 18 mm to 25 mm thick, which is cut to cover all but the exposed strip, as shown in [Figure 11](#).

NOTE The load-spreading sheet is often a sheet of plywood, which distributes load such that failures occur at the location of impact. This sheet is often necessary for testing paper pallets.

Attach the load box centrally on the pallet with the rest of the test load such that loading is central to the axis of movement down the rails, but biased towards the higher end of the pallet.

Bring the dolly and the loaded pallet up to a predetermined position on the incline at a distance, L , from the point of impact and release. Repeat as required.

Carry out a similar sequence of impacts along the second horizontal axis of the pallet.

8.10.4 Measurement

The distortion (x' and y') in X and Y planes and any damage shall be noted. The changes shall be recorded at a number of positions along the impacted surface.

Dimensions in millimetres

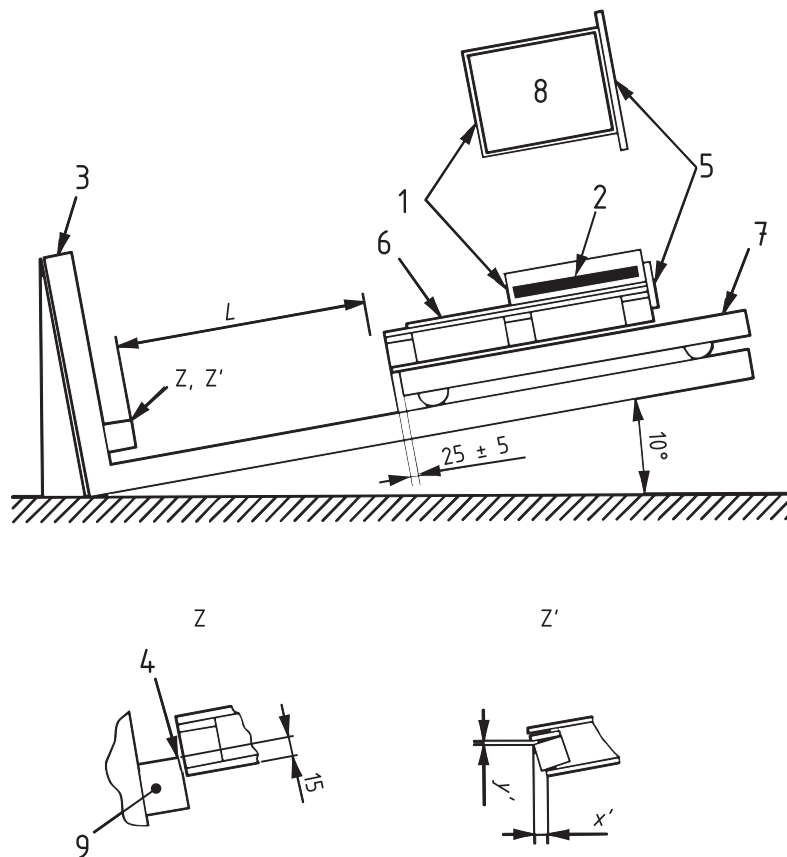

Key

- | | | | |
|---|---------------------------------|------|-----------------------|
| 1 | load box | 7 | dolly |
| 2 | test load | 8 | top view |
| 3 | backstop | 9 | barrier |
| 4 | line of impact 15 mm overlap | x' | distortion in X plane |
| 5 | detachable support for load box | y' | distortion in Y plane |
| 6 | load-spreading sheet | | |

Figure 11 — Shear impact test

8.11 Test 11 — Top deck edge impact test

8.11.1 Purpose

The purpose of this test is to determine the resistance of the top deck edge to side horizontal impacts by the fork arms of a forklift truck.

8.11.2 Procedure

The inclined plane tester described in 8.10.3 is used with the impact stops shown in Figures 12 and 13.

Place the pallet, the load box and the spreading sheet with the test load on the dolly of the incline testing machine so that when the forward edge of the pallet is resting against the impact stops, the dolly is (25 ± 5) mm clear of it. The load shall be central to the axis of movement.

Align the impact stops with the fork openings of the pallet at a height that allows the leading edge to touch the stop surface of the blade at a point between $200 \text{ mm} \pm 25 \text{ mm}$ from the vertical face of the

impact stops (see Figure 12). The points of contact with surface of the blade shall be within this area for each impact. The impact stops shall be positioned at the midpoints between the blocks or stringers.

Raise the pallet with the dolly until the pallet is a distance, L , from the vertical face of the impact stop (see Figure 12) and release. Repeat as required.

Carry out a similar sequence of impacts along the second horizontal axis of the pallet.

8.11.3 Measurement

Deformation (x and y) in X and Y planes shall be recorded. The penetration depth and general damage at points of impact shall also be recorded.

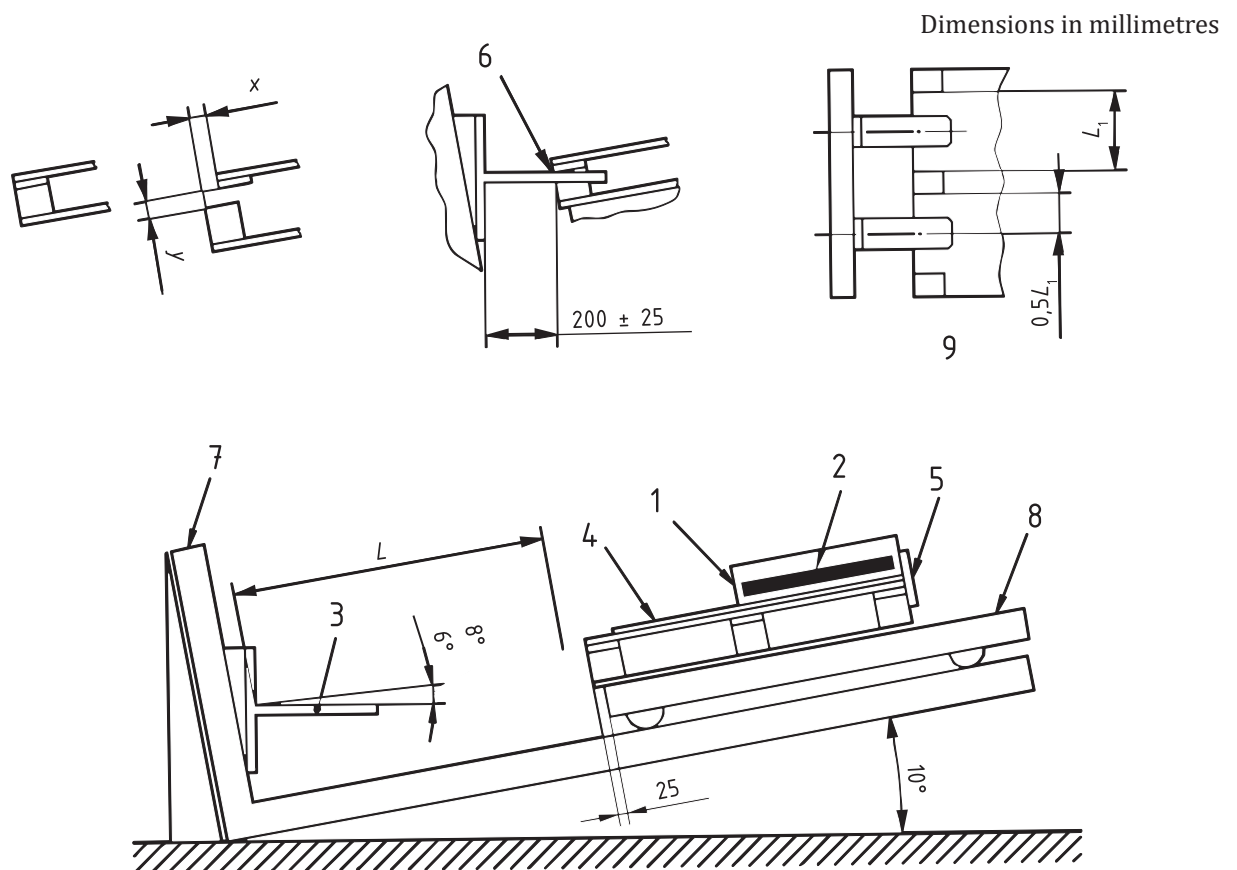

Key

- | | | | |
|---|---------------------------------|-----|---|
| 1 | load box | 7 | backstop |
| 2 | test load | 8 | dolly |
| 3 | impact stop | 9 | top view |
| 4 | load-spreading sheet | L | distance from the point of impact and release |
| 5 | detachable support for load box | x | distortion in X plane |
| 6 | point of impact | y | distortion in Y plane |

Figure 12 — Top deck edge impact test

8.12 Test 12 — Block impact test

8.12.1 Purpose

The purpose of this test is to determine the resistance of blocks, stringers and connections to impact by the fork arm tips of forklift trucks.

8.12.2 Procedure

The inclined plane tester described in 8.10.3 is used with the impact stop as shown in Figure 13.

Place the pallet and load box with the test load on the dolly of the incline test machine so that when the forward edge of the pallet is resting against the tip of the impact stops, the dolly is (25 ± 5) mm clear of it. The load shall be centred with respect to the sides or ends of the pallet.

Dimensions in millimetres

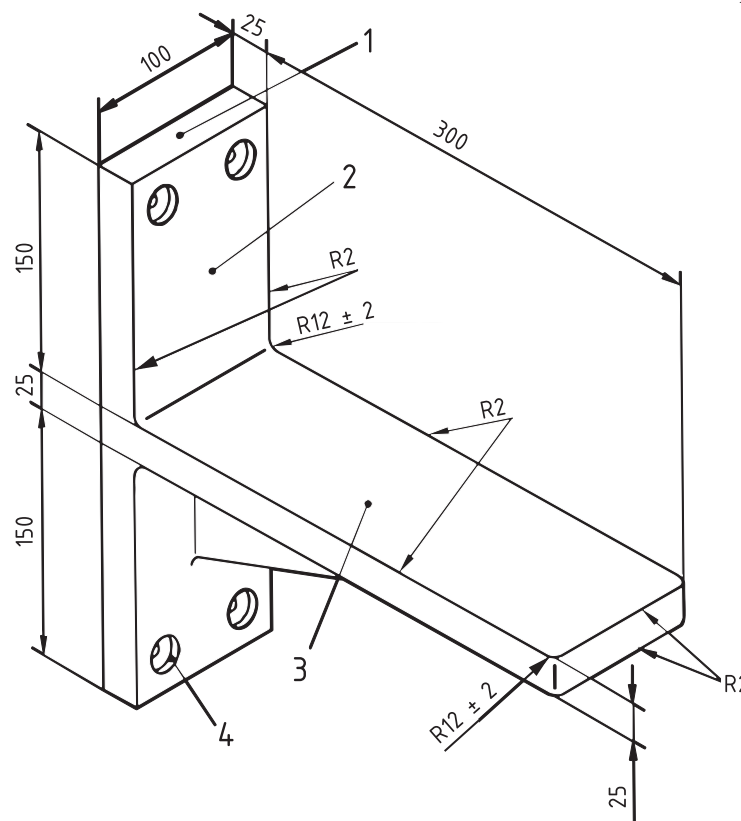

Key

- 1 shank
- 2 shank face
- 3 blade
- 4 counterbore
- R radius of curvature

Figure 13 — Impact stop for top deck edge and block impact tests

Place the pallet so that lines parallel to the direction of travel shall be drawn from the edges of the impact stops through the points on the front face of the blocks D and E shown in Figure 14. The impact stops shall be positioned accordingly, with the top of their leading edge blades 75 mm above the top surface of the dolly and offset 30 mm as shown in the inset to Figure 14.

Raise the dolly and pallet so that they travel a distance, L , before impact then release. Repeat as required.

Carry out a similar sequence of impacts along the second horizontal axis of the pallet.

8.12.3 Measurement

Displacements shall be recorded after each impact, together with indentation depth. All other damage shall be noted.

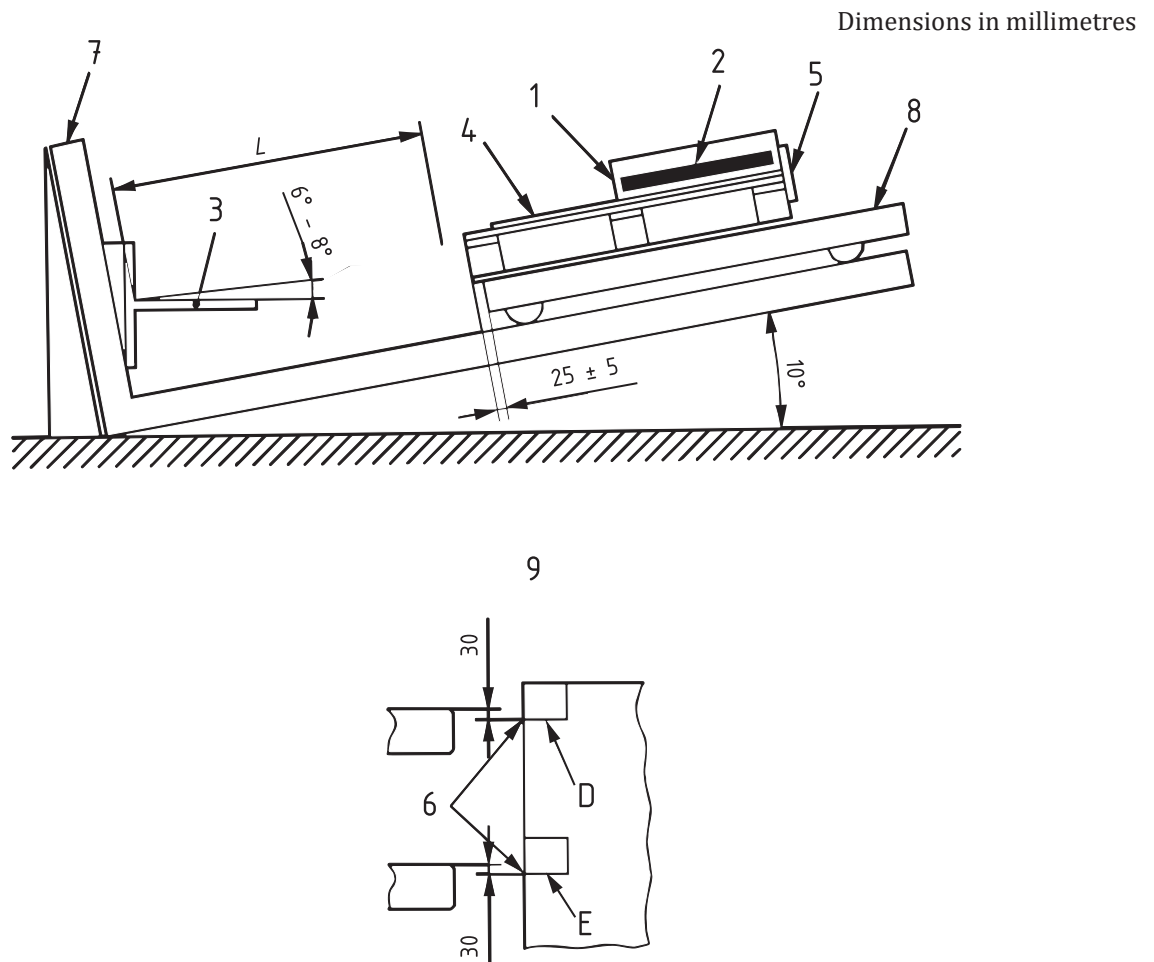

Key

- | | | | |
|---|---------------------------------|-----|---|
| 1 | load box | 6 | points of impact |
| 2 | test load | 7 | backstop |
| 3 | impact stop | 8 | dolly |
| 4 | load-spreading sheet | 9 | top view |
| 5 | detachable support for load box | L | distance from the point of impact and release |

Figure 14 — Incline block impact test

8.13 Test 13 — Static coefficient of friction test

8.13.1 Purpose

The purpose of this test is to determine the static coefficient of friction between the underside of the top deck and the forks of forklift trucks.

NOTE The test is conducted using an unloaded pallet because this result can be used to predict the slip of large masses.

8.13.2 Procedure

Weigh the unloaded pallet, then place it on horizontally positioned, grease-free, dry, steel forks shall be horizontal and level to the nearest 1° as shown in [Figure 15](#). The width of the arms shall be 100 mm.

The test shall be carried out at the openings parallel to the length and parallel to the width of the unloaded pallet. If rubber or high friction inserts are set into the bottom of the top deck, note whether these engage on the steel forks during the test.

8.13.3 Measurement

Gradually increase force until motion commences and record this maximum value, F_s .

$$\mu_s = \frac{F_s}{W_s}$$

where

- μ_s is the static coefficient of friction;
- F_s is the force required to commence movement;
- W_s is the pallet mass.

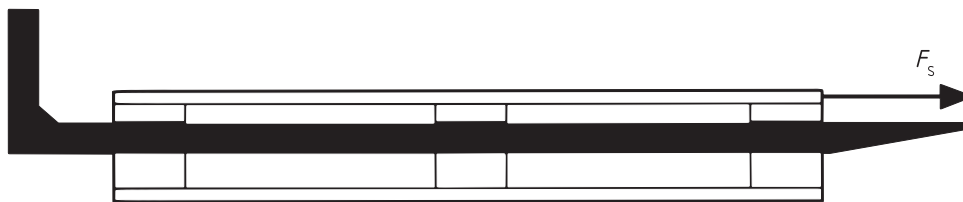

Figure 15 — Static coefficient of friction test

8.14 Test 14 — Slip angle test

8.14.1 Purpose

The purpose of this test is to determine the angle at which the test box commences to slip and thus compare pallet/load interface results for different pallets and construction materials.

8.14.2 Procedure

Load a box 600 mm × 400 mm, having a bottom contact surface faced with a grease-free, dry, steel surface, to 30 kg and tilt the pallet from the horizontal at a rate of $(45^\circ \pm 4,5^\circ)/\text{min}$ as shown in [Figure 16](#). Repeat on the length and width of the pallet.

Slip angle tests are potentially hazardous in view of masses travelling at speed. The design of such test rigs shall incorporate special safety features to reduce risks to both operators and observers and to ensure repeatability.

8.14.3 Measurement

Record the angle, β , at which the load commences to slip down the deck.

NOTE Steel has been chosen as the test surface for repeatability reasons. It is intended that care be exercised when predicting from these tests slip resistance for other packaging materials. It can be necessary to test each actual packaging material to confirm its slip resistance by using it as the friction material in this test.

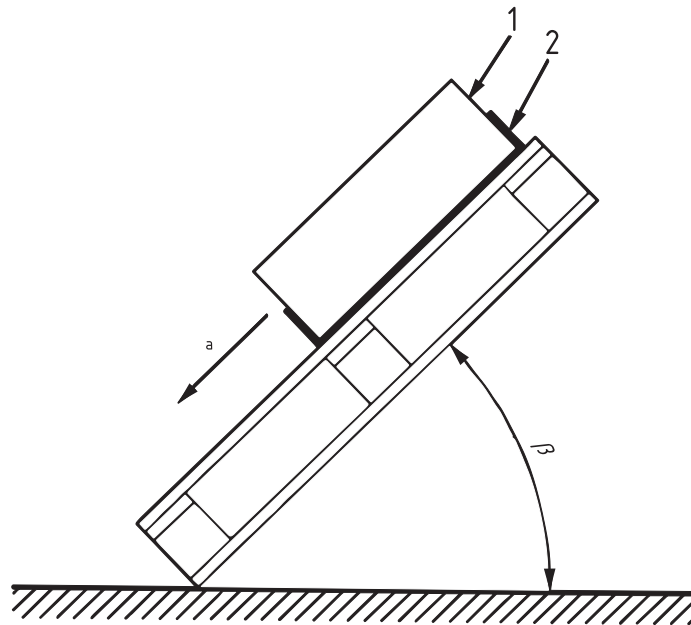

Key

- 1 400 mm × 600 mm box
- 2 friction material
- β angle at which the load commences to slip down the deck
- a Direction of fall.

Figure 16 — Slip angle test

9 Test report

9.1 General information — All materials

The test report for all materials shall contain at least the following:

- a) reference to this document, i.e. ISO 8611-1:2021;
- b) all information necessary for identification of the sample tested;
- c) date of the test;
- d) signature of the tester;
- e) type and dimensions of the pallet (standard or description);
- f) material of the pallet;
- g) test apparatus used;
- h) precision/accuracy of applied loading as appropriate;

- i) location of testing;
- j) laboratory humidity and temperature at the time of test;
- k) number of replicate tests performed;
- l) impact distance(s) (L), test load, number of impacts performed for tests 10, 11 and 12;
- m) test number and test results for each test performed;
- n) results of the test, including the results of the individual determinations and their mean;
- o) any deviations from the procedure specified;
- p) any unusual features (anomalies) observed during the test.

9.2 Information for wooden and wood-based composite pallets

In addition to the information required in [9.1](#), the following information shall be given for wooden and wood-based composite pallets:

- a) species, if feasible, and the density of the components;
- b) moisture content of wood specimens at assembly using electrical resistance method;
- c) moisture content at time of testing;
- d) grade and quality of components;
- e) elapsed time period between specimen assembly and testing, if known;
- f) fasteners used with dimensions and shank profile;
- g) fastener bending strength measured in accordance with ISO 12777-1;
- h) any withdrawal of fasteners during testing.

9.3 Information for plastics pallets

The following information shall be given for plastics pallets:

- a) compound, if feasible, from which the pallet is made;
- b) reference number, serial number, product code, etc.

9.4 Information for pallets made of other materials

The following information shall be given for pallets made of materials other than those covered in [9.2](#) and [9.3](#):

- a) fastening method;
- b) characteristics of the material, if feasible, that affect the pallet performance in tests.

Bibliography

- [1] ISO 8611-3:2011, *Pallets for materials handling — Flat pallets — Part 3: Maximum working loads*
- [2] ISO 3691-5, *Industrial trucks — Safety requirements and verification — Part 5: Pedestrian-propelled trucks*
- [3] ISO 13061-1, *Physical and mechanical properties of wood — Test methods for small clear wood specimens — Part 1: Determination of moisture content for physical and mechanical tests*

[\(Continued from second cover\)](#)

The Committee has reviewed the provisions of following International Standards referred in this adopted standard and has decided that they are acceptable for use in conjunction with this standard:

<i>International Standard/ Other Standard</i>	<i>Title</i>
ISO 8611-2 : 2021	Pallets for materials handling — Flat pallets — Part 2: Performance requirements and selection of tests
ISO 12777-1	Methods of test for pallet joints — Part 1: Determination of bending resistance of pallet nails, other dowel-type fasteners and staples
EN 13183-2	Moisture content of a piece of sawn timber — Part 2: Estimation by electrical resistance method

Attention is drawn to the possibility that some of the elements of this standard may be the subject of patent rights. The Bureau of Indian Standards shall not be held responsible for identifying any or all such patent rights.

In reporting the result of a test or analysis made in accordance with this standard, if the final value, observed or calculated, is to be rounded off it shall be done in accordance with IS 2 : 2022 'Rules for rounding off numerical values (*second revision*)'.

Bureau of Indian Standards

BIS is a statutory institution established under the *Bureau of Indian Standards Act, 2016* to promote harmonious development of the activities of standardization, marking and quality certification of goods and attending to connected matters in the country.

Copyright

BIS has the copyright of all its publications. No part of these publications may be reproduced in any form without the prior permission in writing of BIS. This does not preclude the free use, in the course of implementing the standard, of necessary details, such as symbols and sizes, type or grade designations. Enquiries relating to copyright be addressed to the Head (Publication & Sales), BIS.

Review of Indian Standards

Amendments are issued to standards as the need arises on the basis of comments. Standards are also reviewed periodically; a standard along with amendments is reaffirmed when such review indicates that no changes are needed; if the review indicates that changes are needed, it is taken up for revision. Users of Indian Standards should ascertain that they are in possession of the latest amendments or edition by referring to the website-www.bis.gov.in or www.standardsbis.in.

This Indian Standard has been developed from Doc No.: TED 24 (23325).

Amendments Issued Since Publication

Amend No.	Date of Issue	Text Affected

BUREAU OF INDIAN STANDARDS

Headquarters:

Manak Bhavan, 9 Bahadur Shah Zafar Marg, New Delhi 110002

Telephones: 2323 0131, 2323 3375, 2323 9402

Website: www.bis.gov.in

Regional Offices:

	Telephones
Central : 601/A, Konnectus Tower -1, 6 th Floor, DMRC Building, Bhavbhuti Marg, New Delhi 110002	{ 2323 7617
Eastern : 8 th Floor, Plot No 7/7 & 7/8, CP Block, Sector V, Salt Lake, Kolkata, West Bengal 700091	{ 2367 0012 2320 9474
Northern : Plot No. 4-A, Sector 27-B, Madhya Marg, Chandigarh 160019	{ 265 9930
Southern : C.I.T. Campus, IV Cross Road, Taramani, Chennai 600113	{ 2254 1442 2254 1216
Western : Manakalya, 4 th Floor, NTH Complex (W Sector), F-10, MIDC, Andheri (East), Mumbai 400093	{ 283 25838

Branches : AHMEDABAD, BENGALURU, BHOPAL, BHUBANESHWAR, CHANDIGARH, CHENNAI, COIMBATORE, DEHRADUN, DELHI, FARIDABAD, GHAZIABAD, GUWAHATI, HARYNA, HUBLI, HYDERABAD, JAIPUR, JAMMU & KASHMIR, JAMSHEDPUR, KOCHI, KOLKATA, LUCKNOW, MADURAI, MUMBAI, NAGPUR, NOIDA, PARWANOO, PATNA, PUNE, RAIPUR, RAJKOT, SURAT, VIJAYAWADA.