सड़क वाहन — वाहनों में एंकरेज और चाइल्ड
रिस्ट्रेन सिस्टम के लिए एंकरेज से संयोजन
भाग 2 टोप टीथर एंकरेज और संयोजन

Road Vehicles — Anchorages in
Vehicles and Attachments to
Anchorages for Child Restraint
Systems

Part 2 Top Tether Anchorages and
Attachments

ICS 43.040.80

© BIS 2024

© ISO 2004



भारतीय मानक ब्यूरो
BUREAU OF INDIAN STANDARDS
मानक भवन, 9 बहादुर शाह ज़फर मार्ग, नई दिल्ली - 110002
MANAK BHAVAN, 9 BAHADUR SHAH ZAFAR MARG
NEW DELHI - 110002

www.bis.gov.in www.standardsbis.in

NATIONAL FOREWORD

This Indian Standard (Part 2) which is identical to ISO 13216-2 : 2004 'Road vehicles — Anchorages in vehicles and attachments to anchorages for child restraint systems — Part 2: Top tether anchorages and attachments' issued by International Organization for Standardization (ISO) was adopted by the Bureau of Indian Standards on the recommendation of the Passive Safety Crash Protection Systems Sectional Committee and approval of the Transport Engineering Division Council.

This standard is one of the parts on 'Road vehicles — Anchorages in vehicles and attachments to anchorages for child restraint systems'. Other parts of this standard are:

- Part 1 Seat bight anchorages and attachments
- Part 3 Classification of child restraint system and space in vehicle

The text of ISO standard has been approved as suitable for publication as an Indian Standard without deviations. Certain terminologies and conventions are, however, not identical to those used in Indian Standards. Attention is particularly drawn to the following:

- a) Wherever the words 'International Standard' appear referring to this standard, they should be read as 'Indian Standard'; and
- b) Comma (,) has been used as a decimal marker, while in Indian Standards, the current practice is to use a point (.) as the decimal marker.

In this adopted standard, reference appears to certain International Standard for which Indian Standard also exists. The corresponding Indian Standard, which is to be substituted in its respective place, is listed below along with its degree of equivalence for the editions indicated:

<i>International Standard</i>	<i>Corresponding Indian Standard</i>	<i>Degree of Equivalence</i>
ISO 13216-1 Road vehicles — Anchorages in vehicles and attachments to anchorages for child restraint systems — Part 1: Seat bight anchorages and attachments	IS 18635 (Part 1) : 2024/ ISO 13216-1 : 1999 Road vehicles — Anchorages in vehicles and attachments to anchorages for child restraint systems: Part 1 Seat bight anchorages and attachments	Identical

The Committee has reviewed the provisions of the following International Standards referred in this adopted standard and has decided that they are acceptable for use in conjunction with this standard. For undated references, the latest edition of the referenced document applies, including any corrigenda and amendment.

<i>International Standard/ Other Publications</i>	<i>Title</i>
ISO 6549 : 1999	Road vehicles — Procedure for H- and R-point determination
SAE J1100 : 1993	Motor vehicle dimensions

Attention is drawn to the possibility that some of the elements of this standard may be the subject of patent rights. The Bureau of Indian Standards shall not be held responsible for identifying any or all such patent rights.

Contents

Page

Introduction	iv
1 Scope	1
2 Normative references	1
3 Terms and definitions	1
4 Dimensions and installation requirements	2
5 Child restraint top tether assembly specifications	12
Annex A (normative) Conventional top tether anchorage zones	15
Bibliography	22

Introduction

This part of ISO 13216 specifies top tether anchorages and attachments: a means of limiting the pitch rotation of child restraint systems (CRS) when used in conjunction with the specifications of ISO 13216-1 and which can also be used in conjunction with seat belt systems for CRS installation.

The main body of this document presents a wide installation zone for top tether anchorages intended for CRS with *rigid* ISOFIX seat bight attachments — the “ISOFIX zone” — developed and evaluated in dynamic tests with CRS in combination with rigid ISOFIX seat bight attachments¹⁾.

Annex A specifies top tether anchorage installation zones, referred to as “conventional zones”, which are compatible with current US and Canadian regulations (those required under current Australian regulations are narrower). These conventional zones are applicable to all child restraint systems intended for use with top tether attachments and can be combined with any type of lower attachments: ISOFIX, LATCH or conventional seat belt attachments.

The ISOFIX zones were developed in order to allow more design possibilities for locating the top tether anchorage within the vehicle structure. They are based on the conventional zones, but test results have shown that CRS with rigid ISOFIX attachments can accept wider top tether angles than those in the conventional zones, in both the vertical and horizontal planes, without a reduction in performance.

1) The application of ISOFIX zones to child restraint systems in combination with other types of attachments (LATCH or conventional seat belt attachments) had not been evaluated at time of publication.

Indian Standard

ROAD VEHICLES — ANCHORAGES IN VEHICLES AND
ATTACHMENTS TO ANCHORAGES FOR CHILD RESTRAINT
SYSTEMS

PART 2 TOP TETHER ANCHORAGES AND ATTACHMENTS

IMPORTANT — Measures should be taken to assure that top tether anchorages positioned in the extended part of the ISOFIX zones (i.e. the portions outside the conventional zones) are used only in combination with ISOFIX child restraint systems having *rigid* seat bight attachments. Use of ISOFIX zones for positioning top tether anchorages could result in a positioning that is incompatible with regulations in some countries.

1 Scope

This part of ISO 13216 establishes the positioning zones, dimensions and general and static-strength requirements for top tether anchorages used together with seat bight anchorages according to ISO 13216-1 or with other systems for anchoring child restraint systems (CRS) in road vehicles. It is applicable to child restraint systems intended for children with a mass of up to 22 kg.

NOTE Further specifications for top tether anchorages, straps and connectors could exist in other standards and regulations.

2 Normative references

The following referenced documents are indispensable for the application of this document. For dated references, only the edition cited applies. For undated references, the latest edition of the referenced document (including any amendments) applies.

ISO 6549, *Road Vehicles — Procedure for H- and R-point determination*

ISO 13216-1, *Road vehicles — Anchorages in vehicles and attachments to anchorages for child restraint systems — Part 1: Seat bight anchorages and attachments*

SAE J1100:1993, *Motor vehicle dimensions*

3 Terms and definitions

For the purposes of this document, the terms and definitions given in ISO 13216-1 and the following apply.

3.1

top tether anchorage

feature located on the vehicle in a defined zone, designed to accept a CRS tether strap connector and transfer its restraint forces to the vehicle structure

EXAMPLE Bar, bracket, ring, webbing loop (recessed or unrecessed).

3.2 top tether connector

device used to attach a top tether strap to a top tether anchorage

EXAMPLE Top tether hook (see Figure 8).

3.3 top tether strap

webbing strap which extends from the top of a CRS to the top tether anchorage and which is equipped with an adjustment device, a tension-relieving device and a top tether connector

4 Dimensions and installation requirements

4.1 Top tether anchorage dimensions

The top tether anchorage shall have dimensions permitting the attachment of a top tether connector (hook type).

Sufficient clearance shall be provided around each top tether anchorage to allow latching and unlatching to it (see Figure 9).

4.2 Positioning of top tether anchorage in ISOFIX zones

4.2.1 Anchorage zone determination — CRF

The top tether anchorage shall be located within the zone shown as shaded in Figure 1, using a child restraint fixture (CRF) in a seating position equipped with ISOFIX bars (for CRF dimensions, see ISO 13216-1).

The top tether anchorage shall be located more than 200 mm, but not more than 2 000 mm, from the origin of the top tether strap on the rear face of the CRF, measured along the strap when it is drawn over the seat back to the anchorage.

A top tether anchorage may be recessed in the seat back, provided that it is not in the strap wraparound area at the top of the seat back.

The seating position shall be the seat's rearmost, downmost position with the seat back in its nominal position, or else shall be the seating position recommended by the vehicle manufacturer.

4.2.2 Anchorage zone determination — Seating position

4.2.2.1 Subject to 4.2.2.2, that portion of the top tether anchorage designed to bind with a top tether connector shall be located within the zone shown as shaded in Figures 2 to 6 of the designated seating position for which it is installed, with reference to the H-point of a template according to ISO 6549, and such that

- a) the H-point of the template is located at the unique design H-point of the designated seating position, as defined in SAE J1100:1993, 2.2.11.1, at the full downward and rearward position of the seat, except that the template is located laterally midway between the two lower restraint system anchorages,
- b) the torso line of the template is at the same angle to the vertical plane as the vehicle seat in its most upright position, and
- c) the template is positioned in the vertical longitudinal plane that contains the H-point of the template.

Dimensions in millimetres

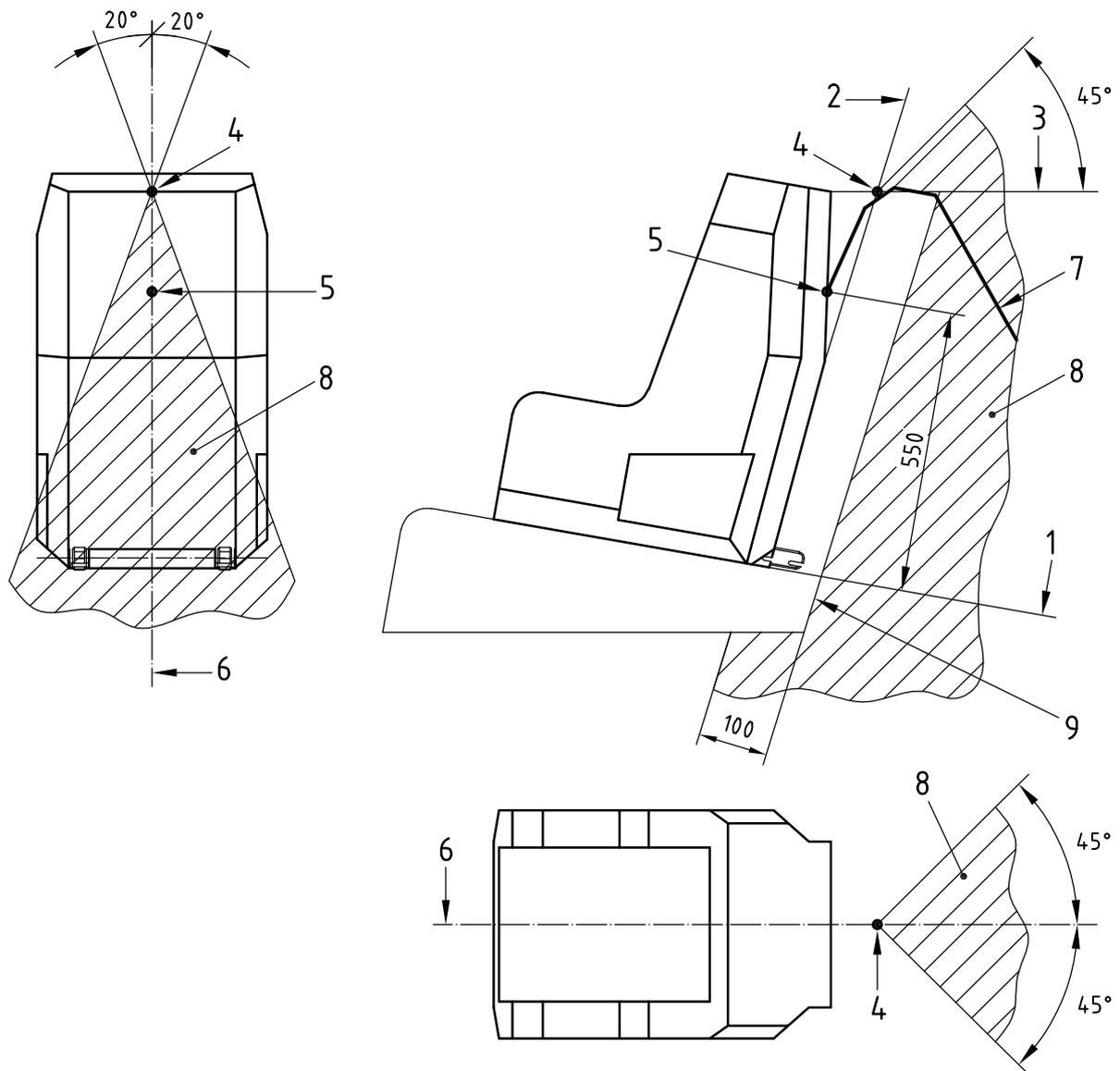

Key

- 1 CRF horizontal face
- 2 CRF rear face
- 3 horizontal line tangent to top of seat back (last rigid point)
- 4 intersection between 2 and 3
- 5 tether reference point
- 6 CRF centreline
- 7 top tether strap
- 8 limits of anchorage zone ^a
- 9 backrest near face

The CRF rests on the seat cushion and the CRF rear face (2) is in contact with the seatback. In the side view, the top tether anchorage lies behind the CRF rear face. The intersection between the CRF rear face and the horizontal (3) line containing the top of the seat back (last rigid point) defines the reference point (4) on the centreline of the CRF. At point 4, a maximum angle of 45° above the horizontal line defines the upper limit of the top tether anchorage zone. In the top view, at point 4, a maximum angle of 90° defines the limits of the anchorage zone. In the rear view, at point 4, a maximum angle of 40° defines the limits of the anchorage zone. The origin of the top tether strap (5) is located 550 mm above the CRF horizontal face (1) on the CRF centreline (6).

^a The anchorage zone shall not extend by more than 100 mm under the seat, in order to allow the anchorage to be reached.

Figure 1 — Top tether anchorage location using CRF — ISOFIX zone

Key

- 1 back angle
- 2 intersection of torso line reference plane and floor pan
- 3 torso line reference plane
- 4 H-point
- 5 V-point ^a
- 6 R-point ^b
- 7 W-point ^c
- 8 vertical longitudinal plane
- 9 strap wraparound length from V-point: 250 mm
- 10 strap wraparound length from W-point: 200 mm
- 11 M-plane cross-section ^d
- 12 R-plane cross-section
- 13 line represents the vehicle specific floor pan surface within the prescribed zone

The portion of the top tether anchorage designed to bind with the top tether hook shall be located within the shaded zone.

NOTE The forwardmost surfaces of the zone are generated by sweeping the two wraparound lines throughout their extended range in the front part of the zone. The wraparound lines represent the minimum adjusted length of typical top tether straps extending from either the top of the CRS (W-point), or lower on the back of the CRS (V-point).

- a V-reference point: 350 mm vertically above and 175 mm horizontally back from the H-point.
- b Shoulder reference point.
- c W-reference point: 50 mm vertically below and 50 mm horizontally back from the R-point.
- d M-reference plane: 1 000 mm horizontally back from the R-point.

Figure 2 — Top tether anchorage location — ISOFIX zone — Side view (*continued*)

Dimensions in millimetres

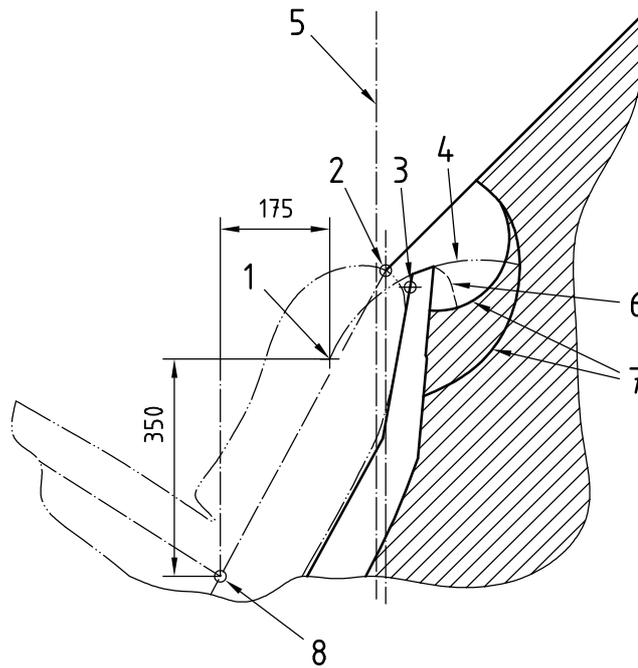

Key

- 1 V-point ^a
- 2 R-point ^b
- 3 W-point ^c
- 4 strap wraparound length from V-point: 250 mm
- 5 vertical longitudinal plane
- 6 strap wraparound length from W-point: 200 mm
- 7 arcs created by wraparound lengths
- 8 H-point

The portion of the top tether anchorage designed to bind with the top tether hook shall be located within the shaded zone.

NOTE The forwardmost surfaces of the zone are generated by sweeping the two wraparound lines throughout their extended range in the front part of the zone. The wraparound lines represent the minimum adjusted length of typical top tether straps extending from either the top of the CRS (W-point), or lower on the back of the CRS (V-point).

- ^a V-reference point: 350 mm vertically above and 175 mm horizontally back from the H-point.
- ^b Shoulder reference point.
- ^c W-reference point: 50 mm vertically below and 50 mm horizontally back from the R-point.

Figure 3 — Top tether anchorage location — ISOFIX zone — Enlarged side view of wraparound area

Dimensions in millimetres

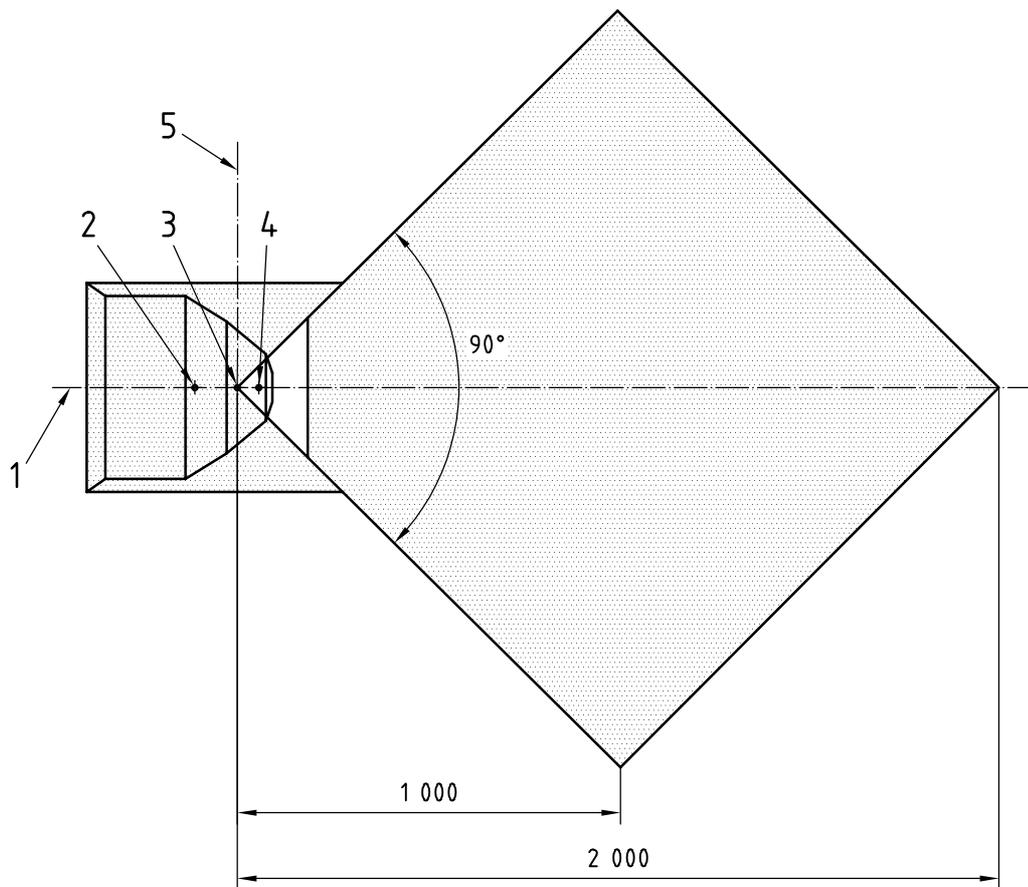

Key

- 1 median plane
- 2 V-point^a
- 3 R-point^b
- 4 W-point^c
- 5 vertical longitudinal plane

The portion of the top tether anchorage designed to bind with the top tether hook shall be located within the shaded zone.

- ^a V-reference point: 350 mm vertically above and 175 mm horizontally back from the H-point.
- ^b Shoulder reference point.
- ^c W-reference point: 50 mm vertically below and 50 mm horizontally back from the R-point.

Figure 4 — Top tether anchorage location — ISOFIX zone — Plan view (R-plane cross-section)

Dimensions in millimetres

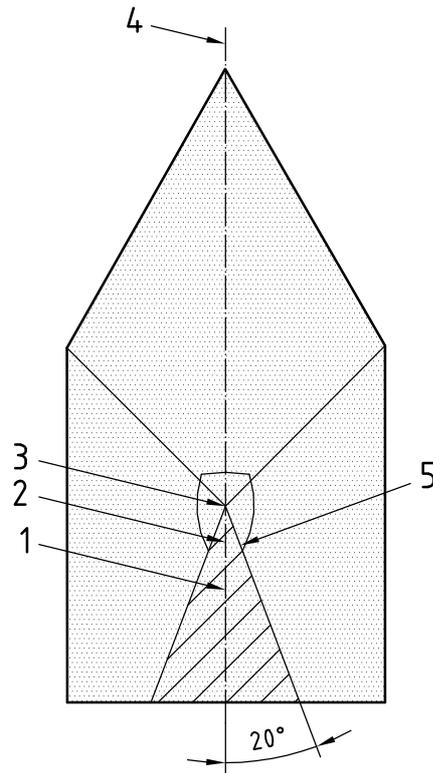

Key

- 1 V-point ^a
- 2 W-point ^b
- 3 R-point ^c
- 4 median plane
- 5 area view along torso reference plane

The portion of the top tether anchorage designed to bind with the top tether hook shall be located within the shaded zone.

- ^a V-reference point: 350 mm vertically above and 175 mm horizontally back from the H-point.
- ^b W-reference point: 50 mm vertically below and 50 mm horizontally back from the R-point.
- ^c Shoulder reference point.

Figure 5 — Top tether anchorage location — ISOFIX zone — Front view

Dimensions in millimetres

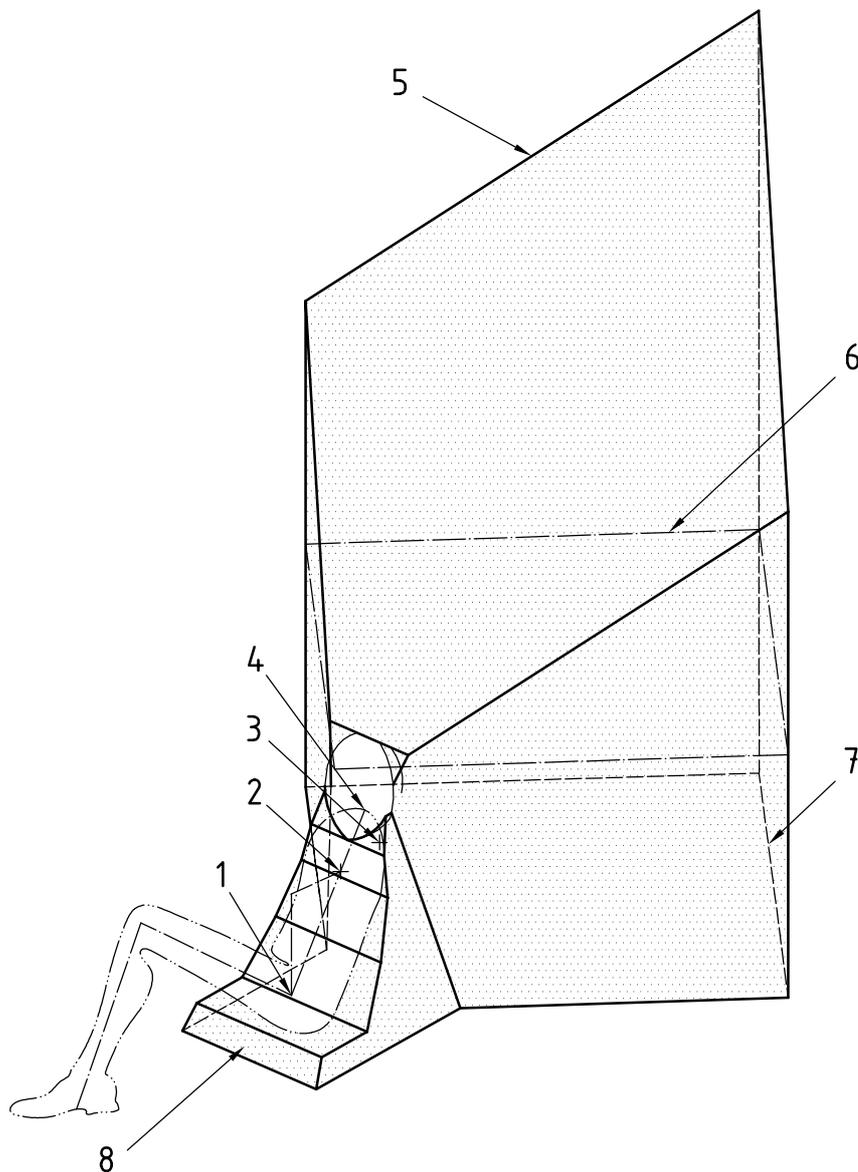

Key

- | | |
|------------------------|-------------------------|
| 1 H-point | 5 45° plane |
| 2 V-point | 6 R-plane cross-section |
| 3 W-point | 7 floor pan surface |
| 4 R-point ^a | 8 front edge of zone |

The portion of the top tether anchorage designed to bind with the top tether hook shall be located within the shaded zone.

^a Shoulder reference point.

Figure 6 — Top tether anchorage location — ISOFIX zone — 3-D schematic view

4.3 Top tether anchorage strength requirements and testing

4.3.1 General

When testing in accordance with 4.3.2 or with the alternative method given in 4.3.3, excursion is not limited, and permanent deformation of the top tether anchorage with respect to the vehicle is acceptable provided that the anchorage does not break or separate from the vehicle.

4.3.2 Strength test method using S-FAD

4.3.2.1 The strength of top tether anchorages shall be determined in accordance with ISO 13216-1:1999, 4.2.1, when applying horizontal forces to the S-FAD (static force application device) shown in Figure 7 of this part of ISO 13216, installed in the vehicle seating position and engaged with the ISOFIX seat bight anchorages and with the top tether anchorage. Low-elongation (7 % to 9 % when applying a force of 11 kN) polyester child restraint/tether strap webbing with a length adjustment device shall be used to connect the tether point on the S-FAD to the top tether anchorage hardware, which shall be representative of production hardware.

4.3.2.2 The vehicle seat shall be installed in the vehicle, or in sufficient parts of the vehicle so as to be representative of the strength and rigidity of the vehicle structure. At the option of the vehicle manufacturer, new components may be installed between successive force application tests. If the seat is adjustable, it shall be placed in the position recommended by the vehicle manufacturer for use with CRS. If no adjusted position is recommended for use with a CRS, the seat shall be placed in the position that provides the most adverse conditions with respect to the ultimate strength of the system.

4.3.2.3 The S-FAD (see Figure 7) shall be installed at a seating position. A rearward force of 135 ± 15 N shall be applied to the centre of the lower front crossbar of the S-FAD to press the device against the seat back as the fore-aft position of the rearward extensions of the S-FAD are adjusted to remove any slack or tension. With the lower attachments in position, adjust the tension in the top tether strap to maximum 50 N. Some compression of the top of the seat back is to be expected.

4.3.2.4 With the S-FAD installed as above, the top of the S-FAD shall displace not more than 10 mm when pulled forward ($0^\circ \pm 5^\circ$) with a force of 100 N, applied horizontally ($0^\circ \pm 5^\circ$) through the tether strap attachment point. If necessary, readjust the top tether strap.

4.3.2.5 Forces shall be applied to the S-FAD in the forward direction ($0^\circ \pm 5^\circ$) with an initial force application angle of $10^\circ \pm 5^\circ$ above the horizontal. A preload force of 500 ± 25 N shall be applied at the prescribed loading point (point X) shown in Figure 7. The force shall be increased to $8 \text{ kN} \pm 0,25 \text{ kN}$ within 2 s and maintained for a period of $0,25 \text{ s} \pm 0,05 \text{ s}$.

4.3.2.6 If anchorages for more than one CRS are installed in the vehicle seat assembly and not directly into the vehicle structure, the forces according to 4.3.2.5 shall be applied simultaneously to S-FAD engaged with the anchorages at each seating position.

4.3.3 Alternative strength test method

4.3.3.1 Alternatively, each top tether anchorage in a row of seating positions shall be caused to withstand the application of a force of 5 300 N, applied by means of a strap that

- a) extends not less than 250 mm forward from the vertical plane touching the rear top edge of the vehicle seat back,
- b) is fitted at one end with suitable hardware for applying the force and at the other end with a bracket for the attachment of the top tether anchorage, and
- c) passes over the top of the vehicle seat back.

4.3.3.2 The force shall be applied in a forward direction ($0^\circ \pm 5^\circ$), initially along a horizontal line or along any line below that line that is at an angle to that line of not more than 20° , shall be attained within 30 s at any onset force rate of not more than 135 000 N/s, and shall be maintained at the 5 300 N level for a minimum of 1 s.

4.3.3.3 If anchorages for more than one child restraint system are installed in the vehicle seat assembly and not directly into the vehicle structure, the force according to 4.3.3.2 shall be applied simultaneously to the anchorages at each seating position.

Dimensions in millimetres

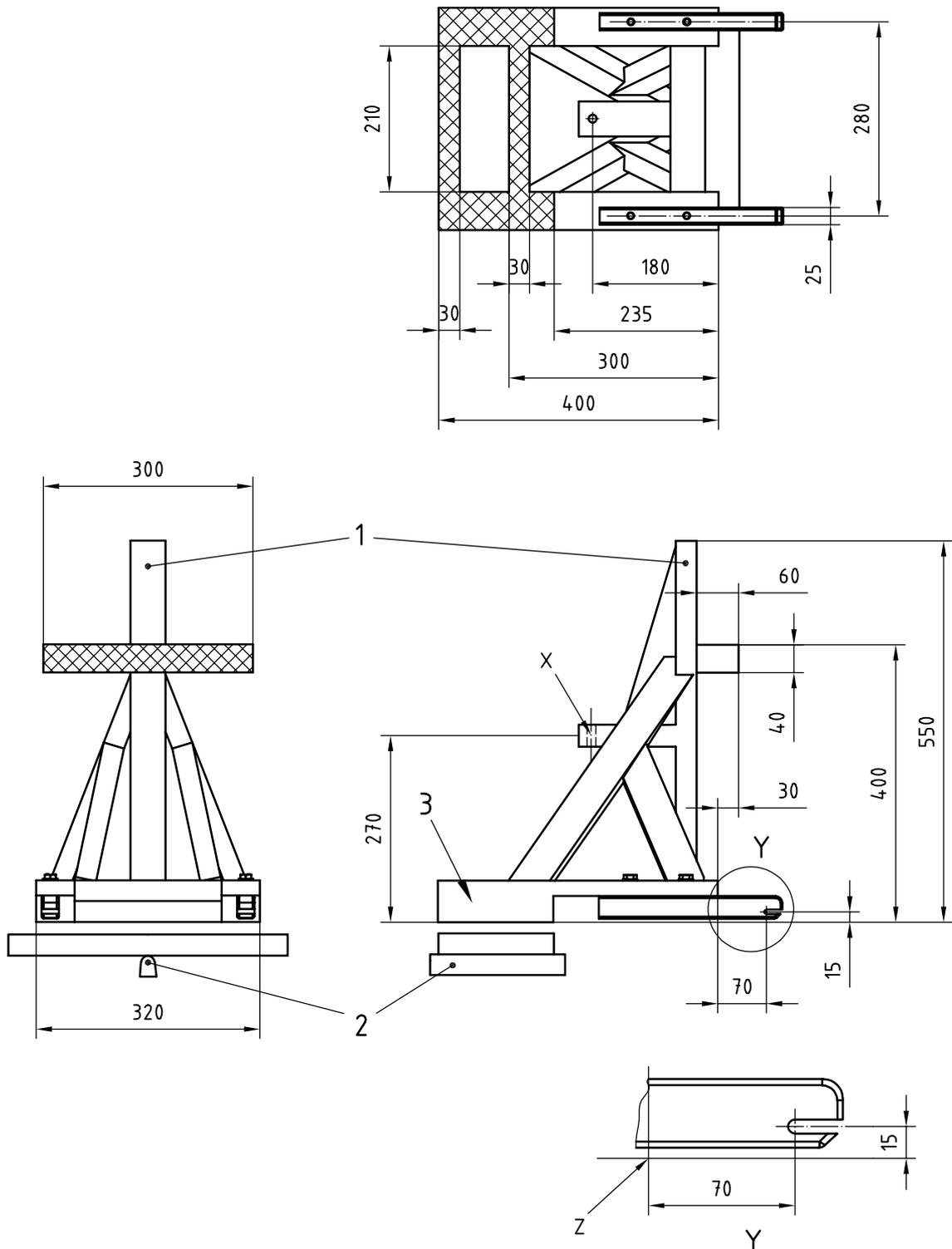

Key

- 1 top tether attachment point
- 2 pivot arrangement for stiffness testing according to ISO 13216-1
- 3 lower front crossbar

Figure 7 — Static force application test device

5 Child restraint top tether assembly specifications

5.1 Attachments — Types

Attachments for top tether straps should be top tether hooks as shown in Figure 8, or similar devices that fit within the envelope shown in Figure 9. The attachments shall be supported by webbing (or its equivalent), having a provision for adjustment and release of tension.

5.2 Top tether strap features

5.2.1 Top tether strap length

The child restraint top tether strap length shall be adjustable from 200 mm to 2 000 mm.

5.2.2 Minimum force indicator

The top tether strap assembly should preferably be equipped with a device that will indicate that a force of 50 N has been introduced to the strap. The device may be part of an adjustment and tension release device.

5.3 Dimensions

Engagement dimensions for top tether hooks are shown in Figure 8.

Dimensions in millimetres

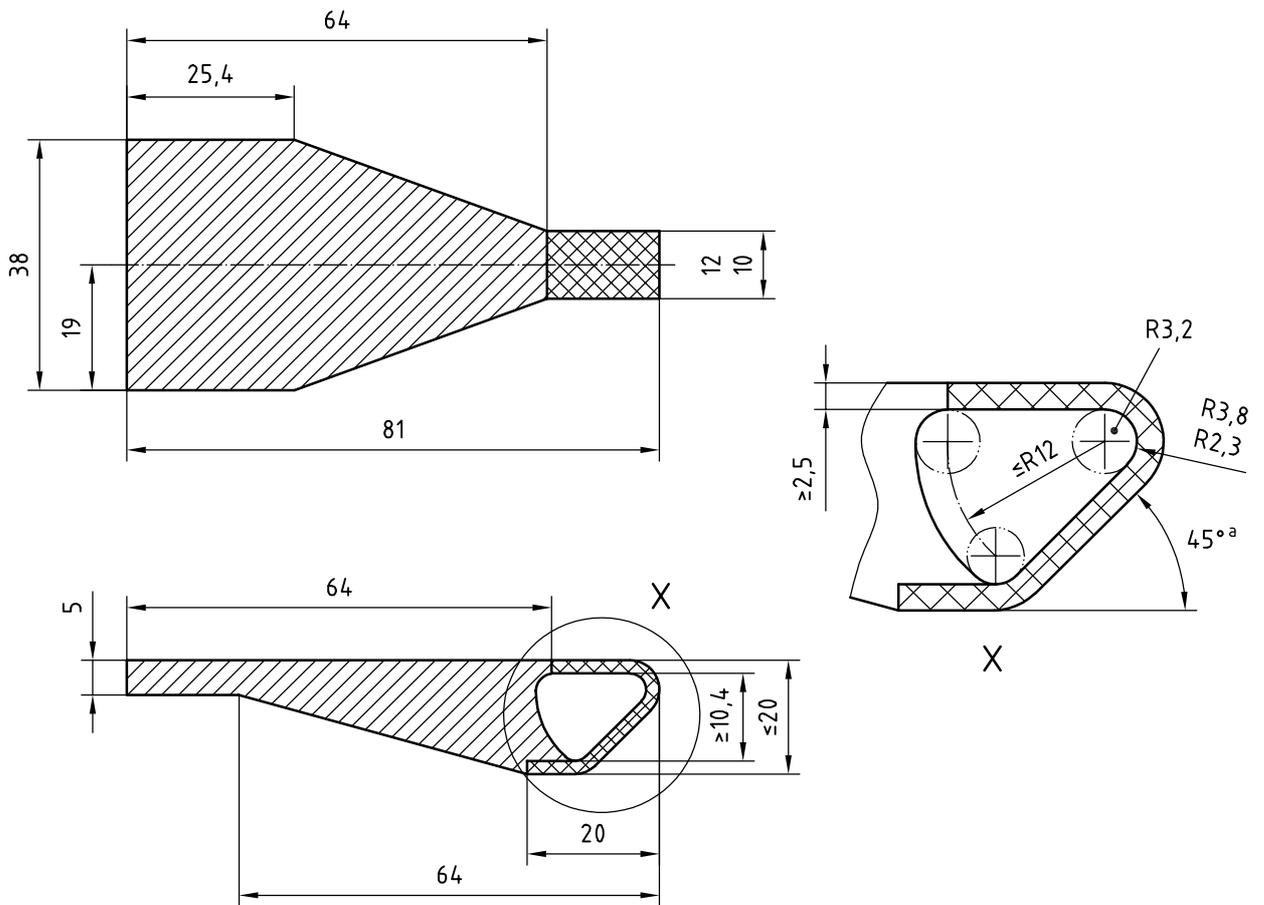

Key



surrounding structure (if present)



area in which the tether hook interface profile shall be wholly located

^a Nominal.

Figure 8 — Top tether connector (hook type) dimensions

Dimensions in millimetres

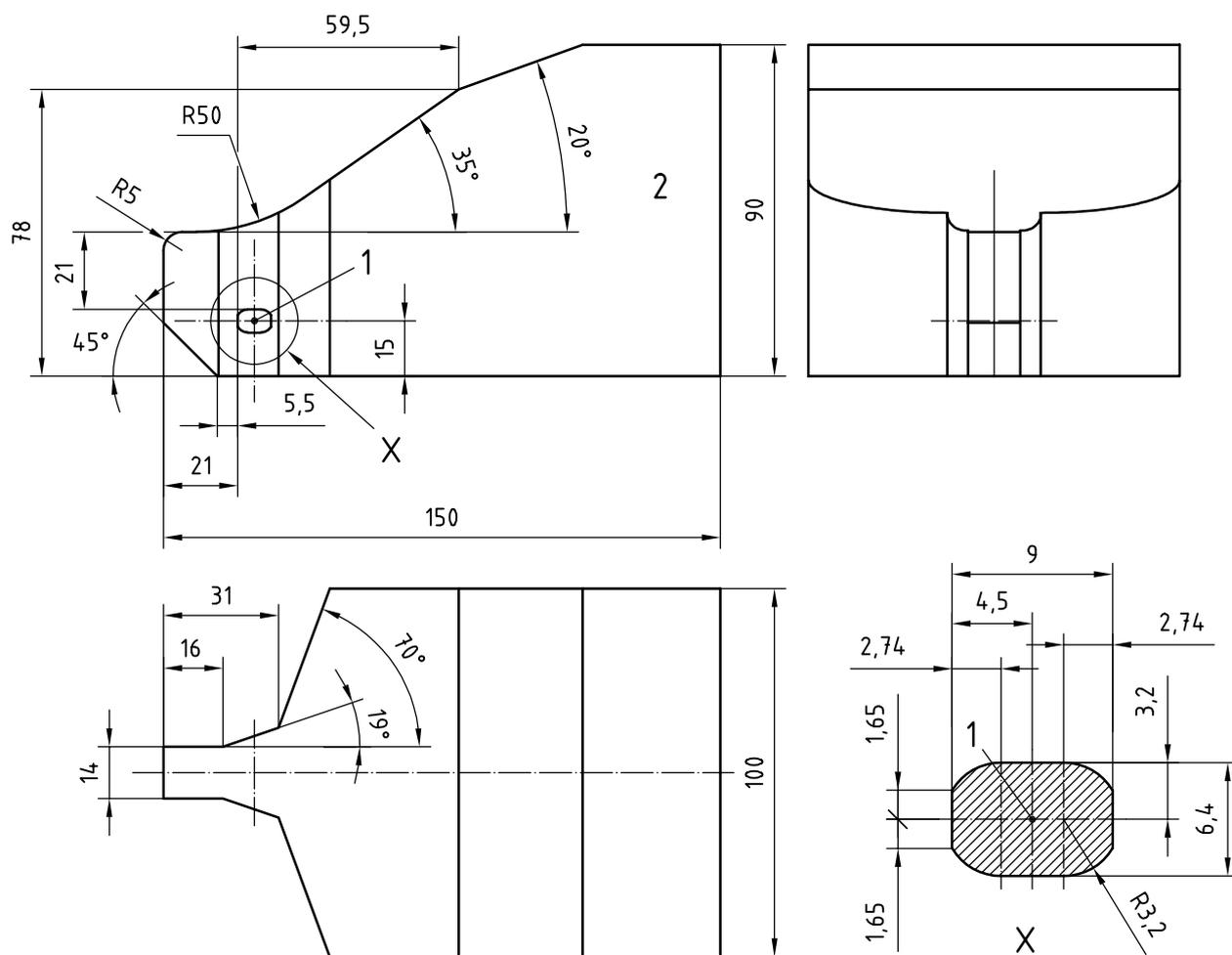

Key

- 1 anchorage profile centre
- 2 clearance space

Clearance space around the top tether anchorage shall allow latching and unlatching of the top tether connector. Values in the figure are minimum dimensions to ensure compatibility with the top tether hook. The figure may be rotated according to the vehicle installation. The actual anchorage profile may be round, oblong or combinations of both, provided it remains within the profile boundaries shown according to detail X. The minimum effective length of the anchorage is 12,5 mm.

NOTE Variations from this zone are permitted, but this zone represents good design practice to assure easy anchor access.

Figure 9 — Clearance space required around top tether anchorage

Annex A (normative)

Conventional top tether anchorage zones

A.1 General

This annex specifies top tether anchorage installation zones compatible with current US and Canadian specifications²⁾, referred to as *conventional zones*. These conventional zones are applicable to all child restraint systems intended for use with top tether attachments, and may be combined with any type of lower attachments (ISOFIX, LATCH, or conventional seat belt attachments).

The dimensional requirements given in 4.1 and the strength requirements given in 4.3 shall apply regardless of the type of zone chosen.

A.2 Top tether anchorage installation requirements for conventional zones

A.2.1 Subject to A.2.2, that portion of the top tether anchorage designed to bind with a top tether connector shall be located within the zone shown as shaded in Figures A.1 to A.6 of the designated seating position for which it is installed, with reference to the H-point of a template according to ISO 6549, and such that

- a) the H-point of the template is located at the unique design H-point of the designated seating position, as defined in SAE J1100:1993, 2.2.11.1, at the full downward and full rearward position of the seat — except in the case of a designated seating position with the means of affixing the lower portion of a CRS to the vehicle other than a vehicle seat belt, in which case the template shall be located laterally, midway between the two lower restraint system anchorages,
- b) the torso line of the template is at the same angle to the vertical plane as the vehicle seat in its most upright position, and
- c) the template is positioned in the vertical longitudinal plane containing the H-point of the template.

A.2.2 If location within the zone specified in A.2.1 is not appropriate, that portion of the top tether anchorage designed to bind with the top tether connector may be located outside the zone, provided the vehicle is equipped with a routing device which

- a) ensures that the top tether strap functions as if the portion of the anchorage designed to bind with the top tether connector were located within the zone,
- b) is at least 65 mm behind the torso line in the case of a non-rigid webbing-type routing device or a deployable routing device, or at least 100 mm behind the torso line in the case of a fixed rigid routing device, and
- c) is of sufficient strength to withstand, when tested after being installed as intended to be used, to withstand, together with the top tether anchorage, the load specified in 4.3.

2) The installation zones specified in the current Australian standard are narrower than those specified here.

Dimensions in millimetres

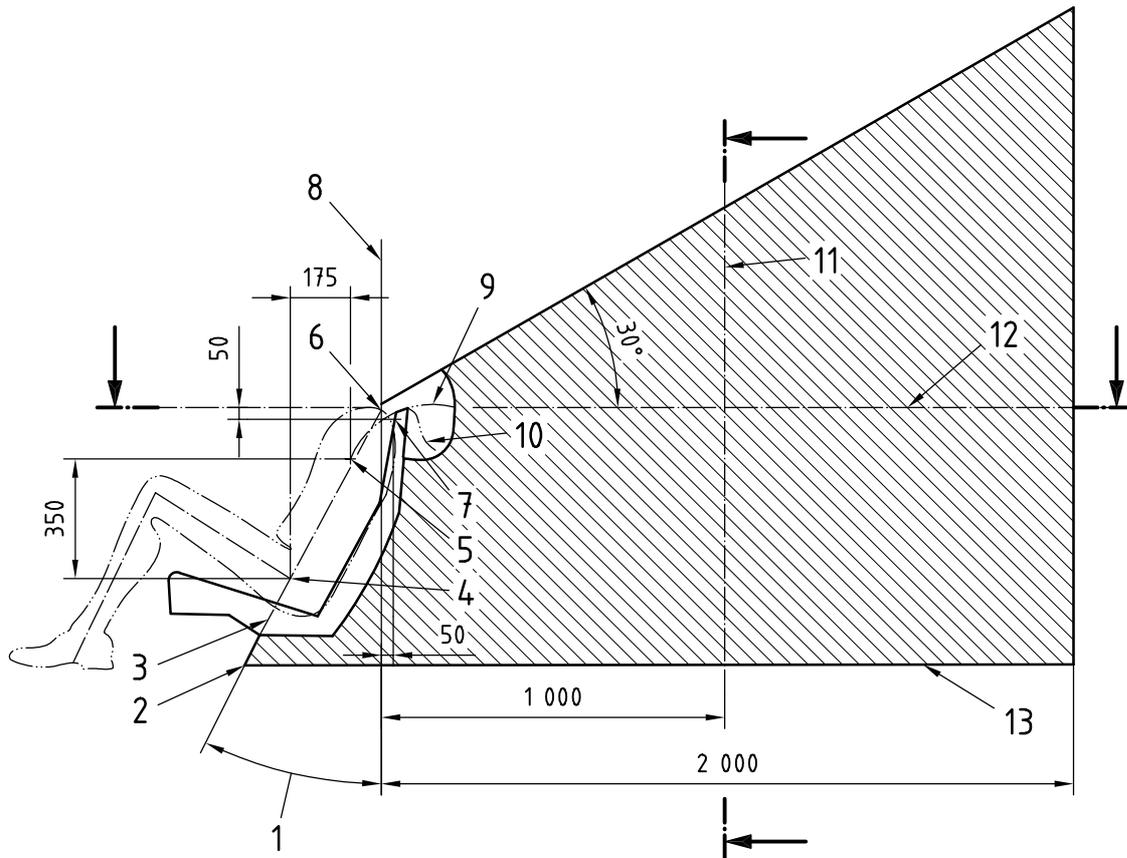

Key

- 1 back angle
- 2 intersection of torso line reference plane and floor pan
- 3 torso line reference plane
- 4 H-point
- 5 V-point ^a
- 6 R-point ^b
- 7 W-point ^c
- 8 vertical longitudinal plane
- 9 strap wraparound length from V-point: 250 mm
- 10 strap wraparound length from W-point: 200 mm
- 11 M-plane cross-section ^d
- 12 R-plane cross-section
- 13 line represents the vehicle specific floor pan surface within the prescribed zone

The portion of the top tether anchorage designed to bind with the top tether hook shall be located within the shaded zone.

NOTE The forwardmost surfaces of the zone are generated by sweeping the two wraparound lines throughout their extended range in the front part of the zone. The wraparound lines represent the minimum adjusted length of typical top tether straps extending from either the top of the CRS (W-point), or lower on the back of the CRS (V-point).

- ^a V-reference point: 350 mm vertically above and 175 mm horizontally back from H-point.
- ^b Shoulder reference point.
- ^c W-reference point: 50 mm vertically below and 50 mm horizontally back from R-point.
- ^d M-reference plane: 1 000 mm horizontally back from R-point.

Figure A.1 — Top tether anchorage location — Conventional zone — Side view

Dimensions in millimetres

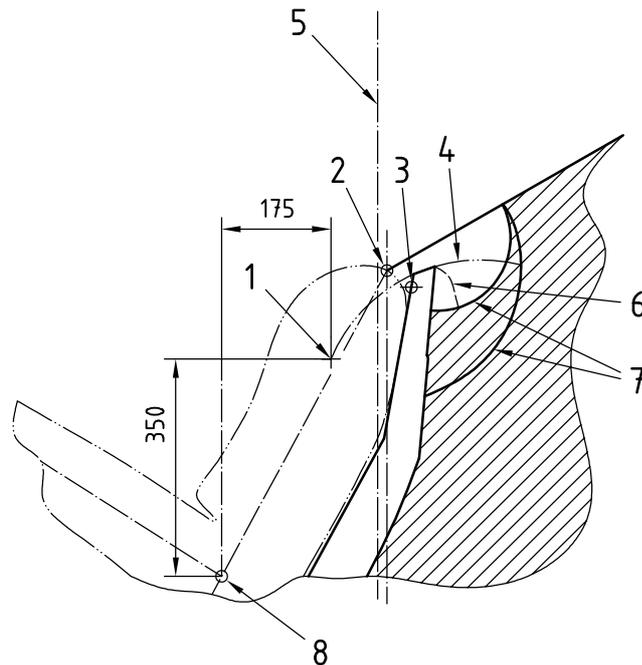

Key

- 1 V-point ^a
- 2 R-point ^b
- 3 W-point ^c
- 4 strap wraparound length from V-point: 250 mm
- 5 vertical longitudinal plane
- 6 strap wraparound length from W-point: 200 mm
- 7 arcs created by wraparound lengths
- 8 H-point

The portion of the top tether anchorage designed to bind with the top tether hook shall be located within the shaded zone.

NOTE The forwardmost surfaces of the zone are generated by sweeping the two wraparound lines throughout their extended range in the front part of the zone. The wraparound lines represent the minimum adjusted length of typical top tether straps extending from either the top of the CRS (W-point), or lower on the back of the CRS (V-point).

- ^a V-reference point: 350 mm vertically above and 175 mm horizontally back from H-point.
- ^b Shoulder reference point
- ^c W-reference point: 50 mm vertically below and 50 mm horizontally back from R-point.

**Figure A.2 — Top tether anchorage location — Conventional zone —
 Enlarged side view of wraparound area**

Dimensions in millimetres

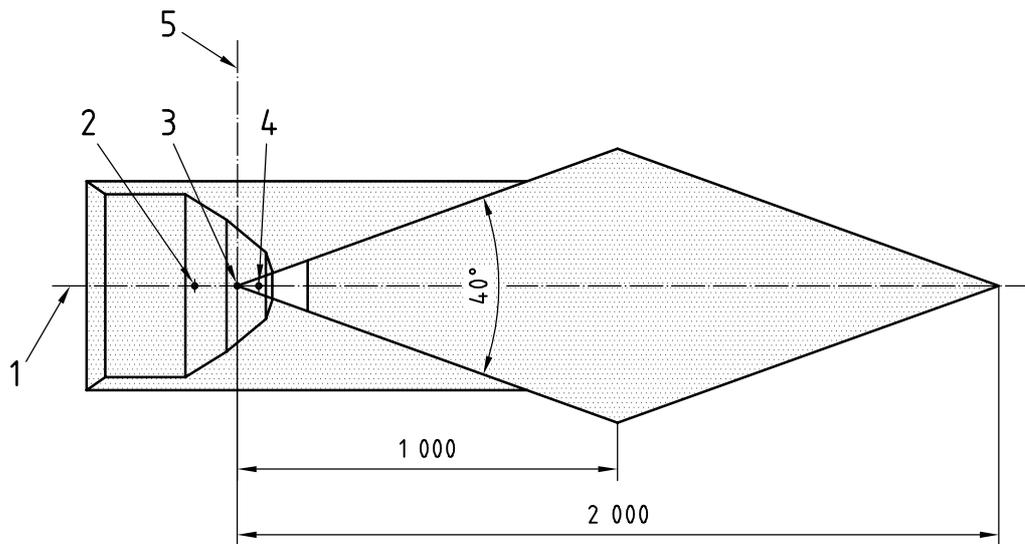

Key

- 1 median plane
- 2 V-point ^a
- 3 R-point ^b
- 4 W-point ^c
- 5 vertical longitudinal plane

The portion of the top tether anchorage designed to bind with the top tether hook shall be located within the shaded zone.

- ^a V-reference point: 350 mm vertically above and 175 mm horizontally back from H-point.
- ^b Shoulder reference point
- ^c W-reference point: 50 mm vertically below and 50 mm horizontally back from R-point.

Figure A.3 — Top tether anchorage location — Conventional zone — Plan view (R-plane cross-section)

Dimensions in millimetres

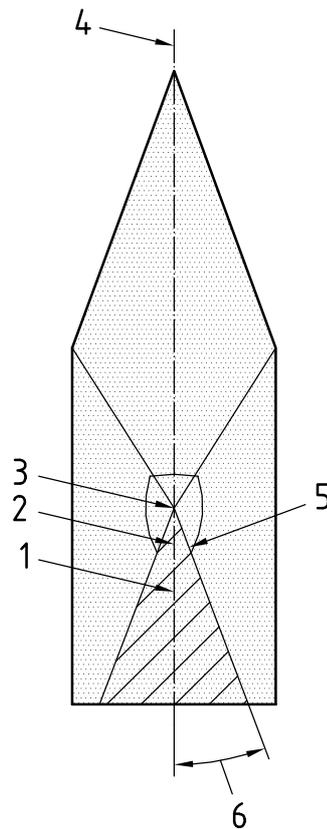

Key

- 1 V-point ^a
- 2 W-point ^b
- 3 R-point ^c
- 4 median plane
- 5 area view along torso reference plane
- 6 20° measured along vertical plane through R-point

The portion of the top tether anchorage designed to bind with the top tether hook shall be located within the shaded zone.

^a V-reference point: 350 mm vertically above and 175 mm horizontally back from H-point.

^b W-reference point: 50 mm vertically below and 50 mm horizontally back from R-point.

^c Shoulder reference point

Figure A.4 — Top tether anchorage location — Conventional zone — Front view

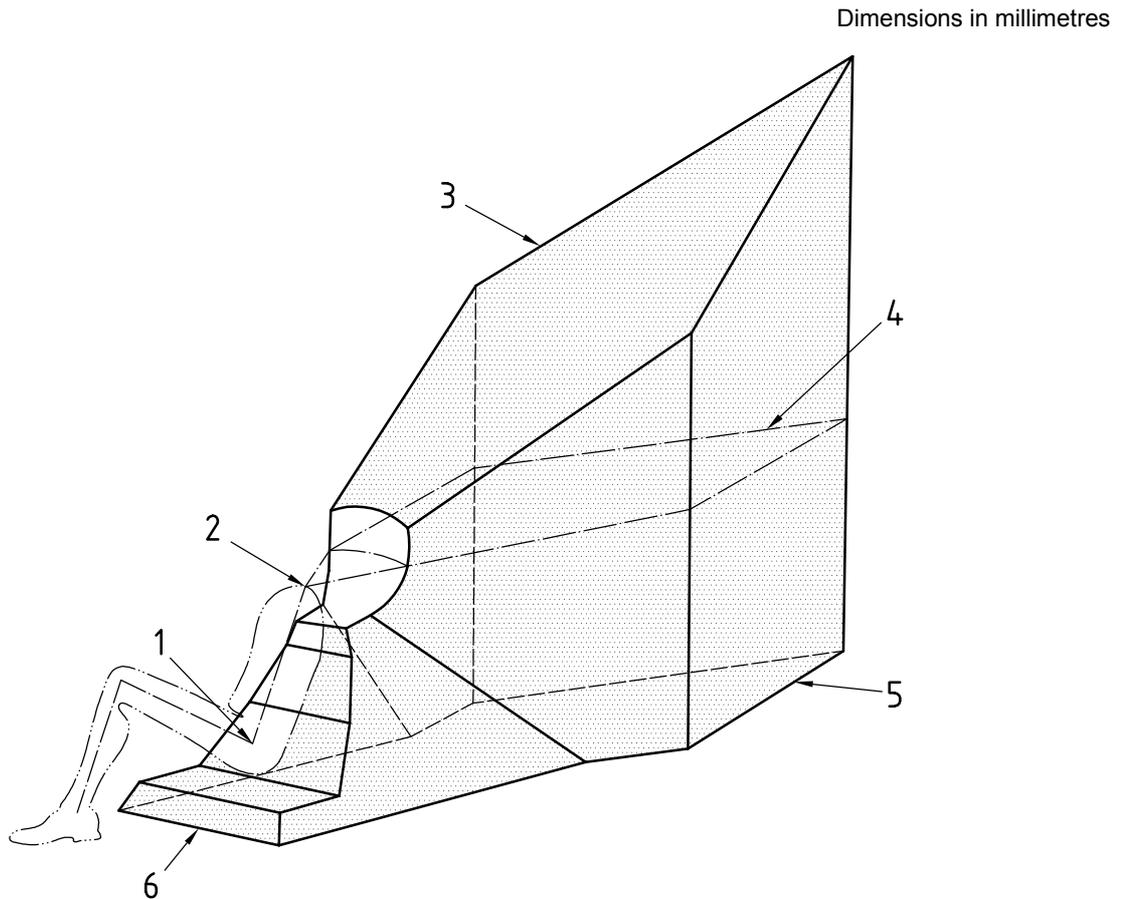

Key

- 1 H-point
- 2 R-point ^a
- 3 30° plane
- 4 R-plane cross-section
- 5 floor pan surface
- 6 front edge of zone

The portion of the top tether anchorage designed to bind with the top tether hook shall be located within the shaded zone.

^a Shoulder reference point.

Figure A.5 — Top tether anchorage location, conventional zone — 3-D schematic view

Dimensions in millimetres

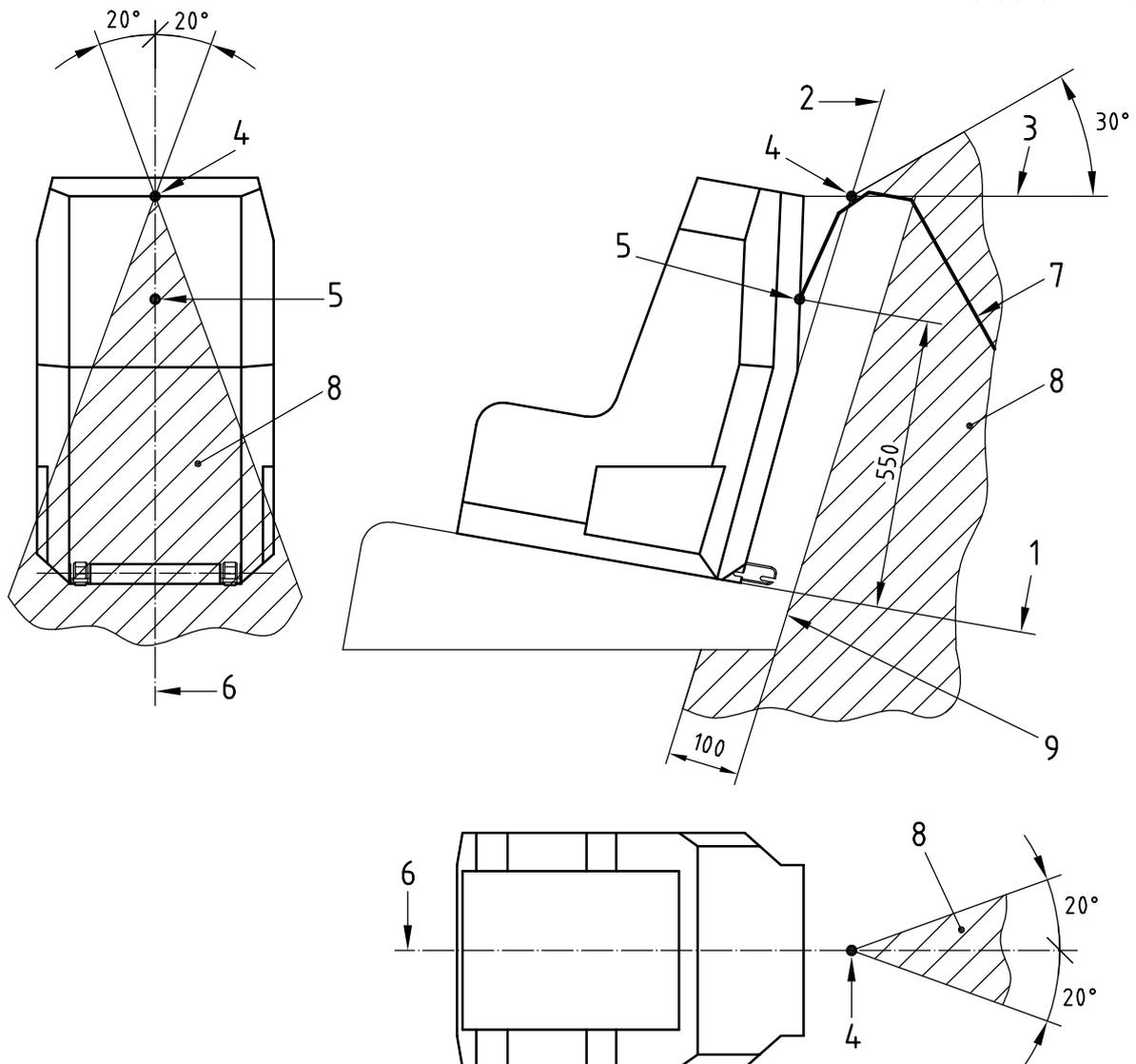

Key

- 1 CRF horizontal face
- 2 CRF rear face
- 3 horizontal line tangent to the top of the seat back (last rigid point)
- 4 intersection between 2 and 3
- 5 tether reference point
- 6 centreline of CRF
- 7 top tether strap
- 8 limits of the anchorage zone
- 9 backrest near face

The CRF rests on the seat cushion and the CRF rear face (2) is in contact with the seatback. In the side view, the top tether anchorage shall lie behind the CRF rear face. The intersection between the CRF rear face and the horizontal (3) line containing the top of the seat back (last rigid point) defines the reference point (4) on the centreline of the CRF. At point 4, a maximum angle of 30° above the horizontal line defines the upper limit of the top tether anchorage zone. In the top view, at point 4, a maximum angle of 40° defines the limits of the anchorage zone. In the rear view, at point 4, a maximum angle of 40° defines the limits of the anchorage zone. The origin of the top tether strap (5) is located 550 mm above the CRF horizontal face (1) on the CRF centreline (6).

Figure A.6 — Alternative method of locating the top tether anchorage, using CRF — Conventional zone

Bibliography

- [1] ISO 13215-2, *Road vehicles — Reduction of misuse risk of child restraint systems — Part 2: Requirements and test procedures for correct installation (panel method)*
- [2] ISO 13215-3, *Road vehicles — Reduction of misuse risk of child restraint systems — Part 3: Prediction and assessment of misuse by Misuse Mode and Effect Analysis (MMEA)*
- [3] ISO 13216-3, *Road vehicles — Anchorages in vehicles and attachments to anchorages for child restraint systems — Part 3: Classification of child restraint dimensions and space in vehicle³⁾*
- [4] ECE Regulation 14, Revision 3, Amendment 2, *Uniform provisions concerning the approval of vehicles with regard to safety-belt anchorages, ISOFIX anchorage systems and ISOFIX top tether anchorages*
- [5] ECE Regulation 44, Revision 1, Amendment 4, *Uniform provisions concerning the approval of restraining devices for child occupants of power-driven vehicles (“child restraint system”)*
- [6] DOT/NHTSA 49 CFR-571, FMVSS 225, *Child restraint anchorage systems⁴⁾*
- [7] CMVSS 210.2, *Universal Attachment System for Infant and Child Restraints Regulations⁵⁾*
- [8] AS 1754, *Child Restraint Systems for Use in Motor Vehicles⁶⁾*
- [9] ADR 34/01, *Child Restraint Anchorages and Child Restraint Anchor fittings⁷⁾*

3) Under preparation.

4) US Federal Motor Vehicle Safety standard

5) Canadian standard

6) Australian standard

7) Australian design rule

Bureau of Indian Standards

BIS is a statutory institution established under the *Bureau of Indian Standards Act, 2016* to promote harmonious development of the activities of standardization, marking and quality certification of goods and attending to connected matters in the country.

Copyright

BIS has the copyright of all its publications. No part of these publications may be reproduced in any form without the prior permission in writing of BIS. This does not preclude the free use, in the course of implementing the standard, of necessary details, such as symbols and sizes, type or grade designations. Enquiries relating to copyright be addressed to the Head (Publication & Sales), BIS.

Review of Indian Standards

Amendments are issued to standards as the need arises on the basis of comments. Standards are also reviewed periodically; a standard along with amendments is reaffirmed when such review indicates that no changes are needed; if the review indicates that changes are needed, it is taken up for revision. Users of Indian Standards should ascertain that they are in possession of the latest amendments or edition by referring to the website- www.bis.gov.in or www.standardsbis.in

This Indian Standard has been developed from Doc No.: TED 29 (23964).

Amendments Issued Since Publication

Amend No.	Date of Issue	Text Affected

BUREAU OF INDIAN STANDARDS

Headquarters:

Manak Bhavan, 9 Bahadur Shah Zafar Marg, New Delhi 110002
Telephones: 2323 0131, 2323 3375, 2323 9402

Website: www.bis.gov.in

Regional Offices:

	Telephones
Central : 601/A, Konnectus Tower -1, 6 th Floor, DMRC Building, Bhavbhuti Marg, New Delhi 110002	{ 2323 7617
Eastern : 8 th Floor, Plot No 7/7 & 7/8, CP Block, Sector V, Salt Lake, Kolkata, West Bengal 700091	{ 2367 0012 2320 9474
Northern : Plot No. 4-A, Sector 27-B, Madhya Marg, Chandigarh 160019	{ 265 9930
Southern : C.I.T. Campus, IV Cross Road, Taramani, Chennai 600113	{ 2254 1442 2254 1216
Western : Plot No. E-9, Road No.-8, MIDC, Andheri (East), Mumbai 400093	{ 2821 8093

Branches : AHMEDABAD. BENGALURU. BHOPAL. BHUBANESHWAR. CHANDIGARH. CHENNAI. COIMBATORE. DEHRADUN. DELHI. FARIDABAD. GHAZIABAD. GUWAHATI. HIMACHAL PRADESH. HUBLI. HYDERABAD. JAIPUR. JAMMU & KASHMIR. JAMSHEDPUR. KOCHI. KOLKATA. LUCKNOW. MADURAI. MUMBAI. NAGPUR. NOIDA. PANIPAT. PATNA. PUNE. RAIPUR. RAJKOT. SURAT. VISAKHAPATNAM.