

(PREVIEW)

*Indian Standard*

**SPECIFICATION FOR  
WOODEN BEATERS**

**1. SCOPE**

**1.1** This standard covers the essential requirements of three types of wooden beaters with handles, as follows:

- a) Wooden beater, flat faced (*see* Fig. 1 );
- b) Wooden beater, flat faced, metal shod (*see* Fig. 2); and
- c) Wooden beater, taper faced, metal shod (*see* Fig. 3 ).

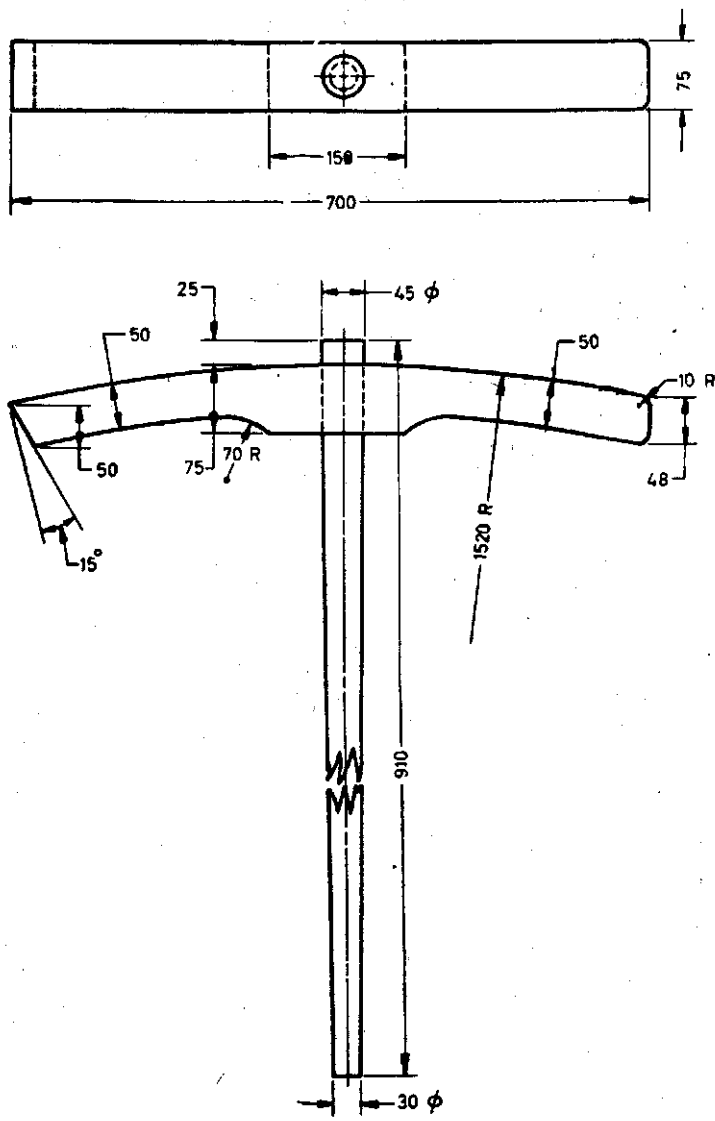

All dimensions in millimetres.

FIG. 1 WOODEN BEATER, FLAT FACED

IS: 3806 -1966

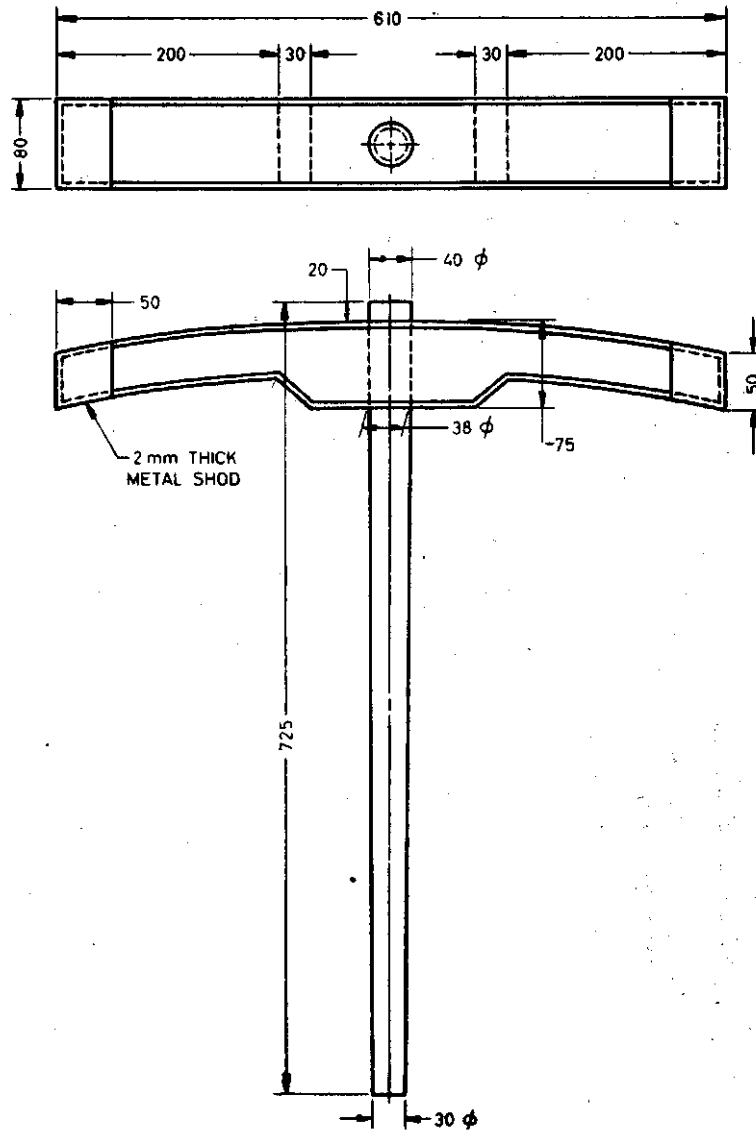

All dimensions in millimetres.

FIG. 2 WOODEN BEATER, FLAT FACED, METAL SHOD

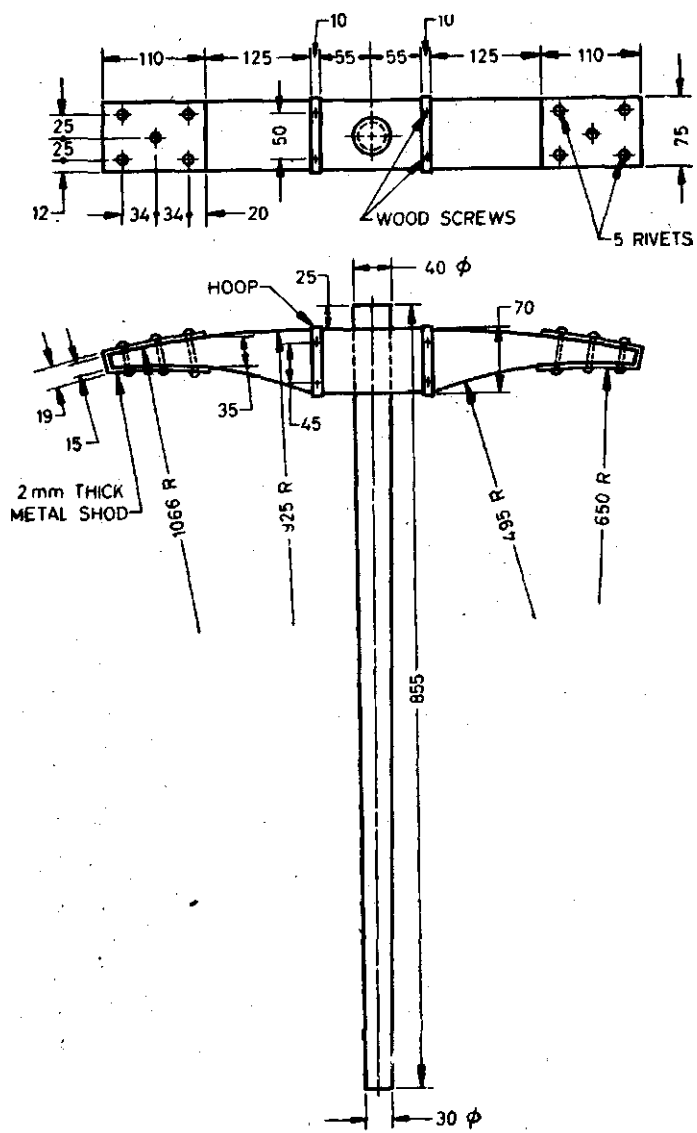

All dimensions in millimetres.

FIG. 3 WOODEN BEATER, TAPER FACED, METAL SHOD