

BUREAU OF INDIAN STANDARDS

DRAFT FOR COMMENTS ONLY

(Not to be reproduced without permission of BIS or used as an Indian Standard)

भारतीय मानक मसौदा

**ट्रैक्टर और ट्रेलर के बीच वैक्यूम और प्रेशर सिस्टम कनेक्शन के लिए 'कॉन्टैक्ट' प्रकार के
युग्मन के लिए विशिष्टता
(पहला पुनरीक्षण)**

Draft Indian Standard

**SPECIFICATION FOR 'CONTACT' TYPE COUPLING FOR VACUUM AND
PRESSURE SYSTEMS CONNECTION BETWEEN TRACTOR AND TRAILER
(First Revision)**

ICS: 43.040.70

Not to be reproduced without permission of BIS
or used as standard

Last date for receipt of comments
is XX/XX/XXXX

Transport Tractors, Trailers and Industrial Trucks Sectional Committee, TED 22

FOREWORD

(Formal clause to be added later on)

In the preparation of this standard, assistance has been derived from BS AU 5: 1963 ‘specification for dimensions of a ‘contact’ type coupling for vacuum and pressure braking systems on trailers and semi-trailers’, issued by the British Standards Institution (BSI).

In this first revision following changes have been incorporated:

- a) References, ICS No. have been updated; and
- b) Other editorial changes have been done to bring the standard in the latest style and format of Indian Standards

The composition of the Committee responsible for the formulation of this standard is given at Annex XXX **(Will be added later)**.

For the purpose of deciding whether a particular requirement of this standard is complied with, the final value, observed or calculated, expressing the result of test or analysis, shall be rounded off in accordance with IS 2: 2022 ‘Rules for rounding off numerical values (*second revision*)’. The number of significant places retained in the rounded off value should be the same as that of the specified value in this standard.

Draft Indian Standard

SPECIFICATION FOR 'CONTACT' TYPE COUPLING FOR VACUUM AND PRESSURE SYSTEMS CONNECTION BETWEEN TRACTOR AND TRAILER
(First Revision)

1 SCOPE

Specifies the form and dimensions of 'contact' type coupling for vacuum and pressure systems connection between tractor and trailer.

NOTE — Coupling for braking system shall be according to IS 9905.

2 REFERENCES

The standard listed below contain provisions which, through reference in this text, constitute provisions of this standard. At the time of publication, the edition indicated was valid. Standard is subject to revision, and parties to agreements based on this standard is encouraged to investigate the possibility of applying the most recent edition of the standard listed below.

<i>IS No.</i>	<i>Title</i>
IS 9905 : 1981	Specification for pneumatic coupling between tractors and trailers

3 DIMENSIONAL

3.1 The dimensions and general arrangements of 'contact' type coupling shall be as shown in Fig. 1, 2 and 3.

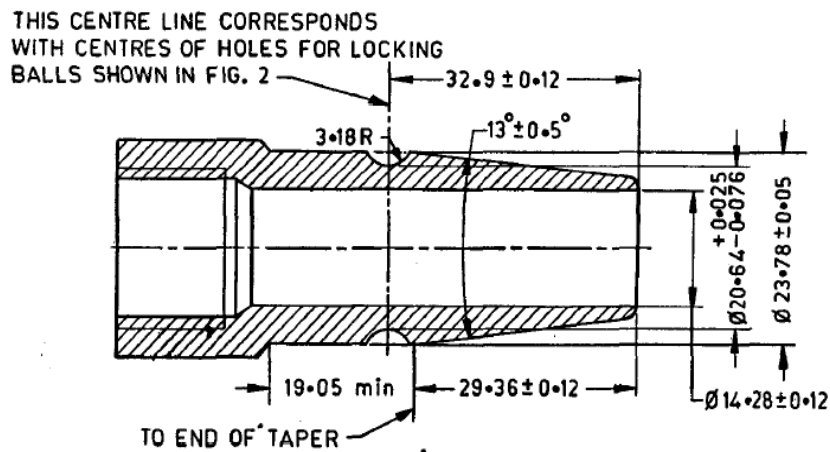

All dimensions in millimetres.

FIG. 1 MALE MEMBER

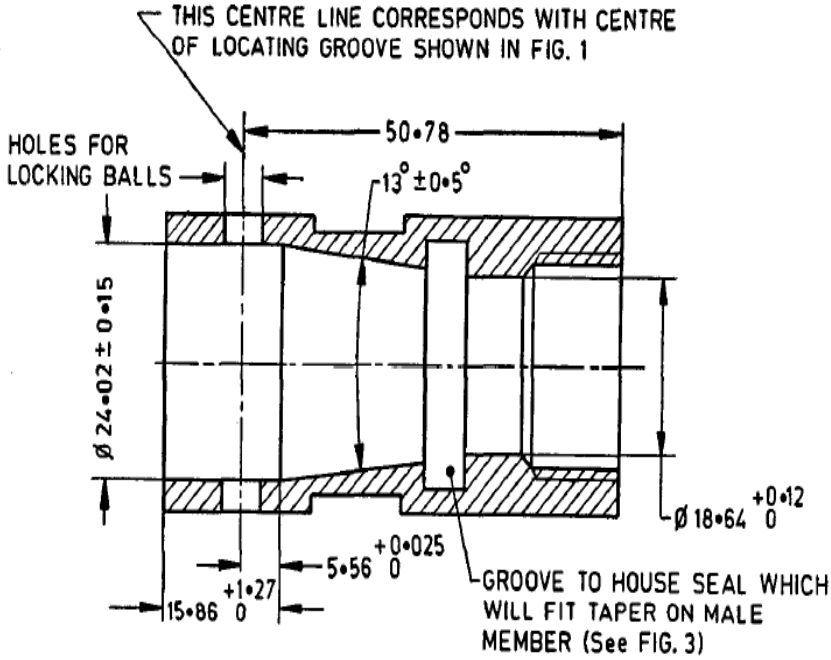

All dimensions in millimetres.

FIG. 2 FEMALE MEMBER

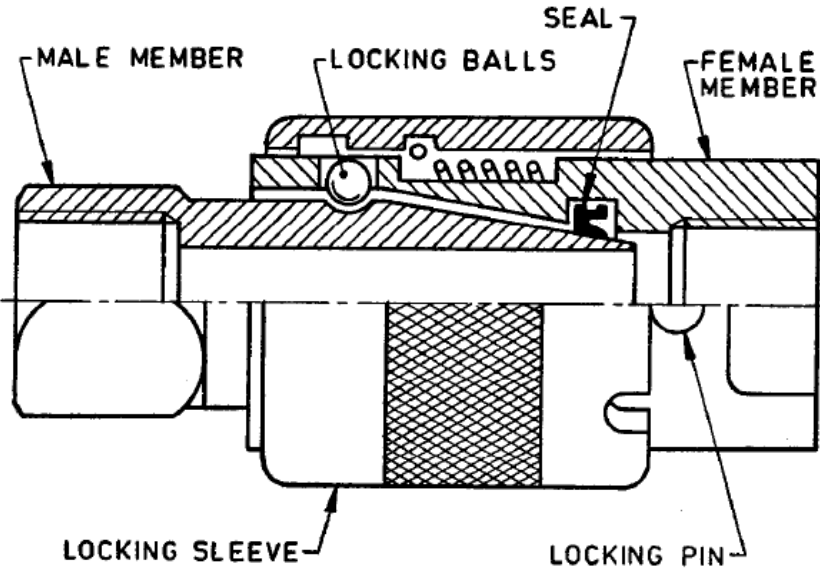

FIG. 3 HALF SECTIONED GENERAL ARRANGEMENT OF CONTACT COUPLING

4 BIS Certification Marking

4.1 Each 'Contact' type coupling may also be marked with the Standard Mark.

4.2 The use of the Standard Mark is governed by the provisions of the *Bureau of Indian Standards Act, 2016* and the Rules and Regulations made thereunder. The details of conditions under which the license for the use of the Standard Mark may be granted to manufacturers or producers may be obtained from the Bureau of Indian Standards.

ANNEX A
(Foreword)

COMMITTEE COMPOSITION

Transport Tractors, Trailers and Industrial Trucks Sectional Committee, TED 22

Will be Added Later.

