

BUREAU OF INDIAN STANDARDS

DRAFT FOR COMMENTS ONLY

(Not to be reproduced without permission of BIS or used as an Indian Standard)

METHODS OF TEST FOR INDUSTRIAL TRACTORS

(ICS 53.060)

Transport Tractors, Trailers and Industrial Trucks Committee, TED 22	Section	Last Date for Comments: 15.11.2022
---	---------	------------------------------------

Transport Tractors, Trailers and Industrial Trucks Sectional Committee, TED 22

FOREWORD

(Formal clause to be added later on)

IS 11683: 1986 was based on BS 2800: 1957 'Tests for industrial crawler and wheeled tractors (excluding units designed for materials handling in factories)', issued by the British Standards Institution (BSI).

Wherever reference to bar is mentioned, $1\text{bar} = 10^5\text{N/m}^2$ can be taken for calculation pressure.

For the purpose of deciding whether a particular requirement of this standard is complied with, the final value, observed or calculated, expressing the result of a test or analysis, shall be rounded off in accordance with IS 2: 2022 'Rules for rounding off numerical values (revised)'. The number of significant places retained in the rounded off value should be the same as that of the specified value in this standard.

*Draft Indian Standard***METHODS OF TEST FOR INDUSTRIAL TRACTORS**
*(First Revision)***1 SCOPE**

This standard specifies methods of tests for industrial tractors.

2 REFERENCES

The following standard contains provision, which through reference in this text constitutes provision of the standard. At the time of publication, the edition indicated was valid. All standards are subject to revision and parties to agreements based on this standard is encouraged to investigate the possibility of applying the most recent edition of the standard indicated below:

<i>IS No.</i>	<i>Title</i>
IS 1460-2017	Automotive diesel fuel - Specification (Sixth Revision)
IS 10000 (Part 1) : 1980	Methods of tests for internal combustion engines: Part 1 glossary of terms relating to test methods
IS 10000 (Part 2) : 1980	Methods of tests for internal combustion engines Part 2 standar d reference conditions
IS 10000 (Part 3) : 1980	Methods of tests for internal combustion engines: Part 3 measurements for testing - Units and limits of accuracy
IS 10000 (Part 4) : 1980	Methods of tests for internal combustion engines: Part 4 declaration of power, efficiency, fuel consumption and lubricating oil consumption
IS 10000 (Part 5) : 1980	Methods of tests for internal combustion engines: Part 5 preparation for tests and measurements for wear
IS 10000 (Part 6) : 1980	Methods of tests for internal combustion engines: Part 6 recording of test results
IS 10000 (Part 7) : 1980	Methods of tests for internal combustion, engines: Part 7 governing tests for constant speed engines and selection of engines for use with electrical generators
IS 10000 (Part 8) : 1980	Methods of tests for internal combustion engines Part 8 performance tests
IS 10000 (Part 9) : 1980	Methods of tests for internal combustion engines: Part 9 endurance tests

- IS 10000 (Part 10) : 1980 Methods of tests for internal combustion engines: Part 10 tests for smoke levels, limits and corrections for smoke levels for variable ,speed compression ignition engines
- IS 10000 (Part 11) : 1980
Methods of tests for internal combustion engines: Part 11 information to be supplied by the purchaser to the manufacturer and information to be supplied by the manufacturer along with the engine
- IS 10000 (Part 12) : 1980 Methods of tests for internal combustion engines: Part 12 specimen test certificates
- IS 10000 (Part 13) : 2002 Methods of tests for internal combustion engines: Part 13 recommendations on nature of tests required for functional changes in critical components
- IS 9701 : 2019 Powered industrial trucks and tractors - Brake performance and component strength (Second Revision)

3 TERMINOLOGY

3.1 Turning Centre — The point about which all parts of a vehicle or a combination of vehicles revolve in describing a turn of constant radius. For ideal steering, free of tyre scrubbing, the extended axis of all wheel spindles passes through this centre. In case of two-axled bogies or tandems in which the axles are constrained to parallelism, the turning centre is assumed to fall on a line parallel to and midway between these axle centrelines (*see* Fig. 1).

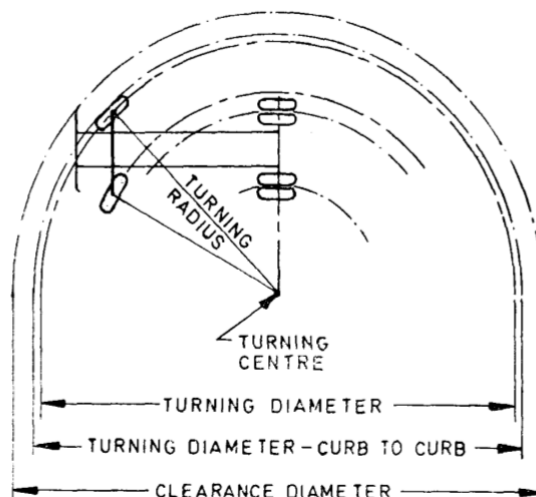

FIG. 1 CLEARANCE CIRCLE TEST

3.2 Turning Radius — The distance from turning centre to the centre of tyre contact with the road of the wheel describing the largest circle while the vehicle is executing its sharpest practicable turn (usually to the outside front wheel) (*see* Fig. 1).

3.3 Turning Diameter — Twice the turning radius (*see* Fig. 1).

3.4 Clearance Diameter — Diameter of the smallest circle which encloses the outermost points of projection of the vehicle while executing its sharpest practicable turn. This is equal to a minimum turning diameter plus twice the radial overhand beyond the turning radius (*see* Fig. 1).

4 GENERAL

4.1 Tractor tests according to this standard shall be carried out by the manufacturer in the presence of the purchaser,

4.2 The standard shall form a basis for acceptance tests made at the request of a purchaser.

4.3 Before commencing the tests, the manufacturer shall ensure that the complete tractor has been satisfactorily run-in.

5 TESTS

5.1 Engine Tests

Engine installed in the tractor shall carry a test certificate issued by the engine manufacturer as per IS: 10000 (Part 1 to 13).

5.2 Drawbar Tests

5.2.1 Drawbar tests on tracklaying tractors shall be carried out on dry, level, mown or grazed grassland on a clay soil or on a track having equally good adhesion characteristics. As a guide to Suitable track conditions, the cohesive strength of the soil shall not be less than 0.5 bar **at** a depth of 50.8 mm and shall preferably not exceed 0.82 bar. This data refers to measurements made by torsional shear test, details of which are given in Annex A.

5.2.1.1 For pneumatic-tyred tractors, drawbar tests shall be carried out on a level, dry, bituminous or concrete surface.

5.2.2 The tractor shall be coupled through a drawbar dynamometer to some convenient form of drawbar load and the line of draught shall be parallel to the ground. The drawbar horsepower recorded throughout the tests shall be the horsepower developed at the drawbar without any allowance for losses due to track or wheel slip.

5.2.3 The drawbar tests shall be carried out with the drawbar hitch point at a height above the ground level which is recommended by the manufacturer. The height of the drawbar hitch point above the ground during the tests shall be measured to the centre of the drawbar clevis and shall be recorded in the report giving the tractor specifications.

5.2.4 The tractor may be equipped for drawbar tests with any track or wheel equipment which is commercially available, together with any ancillary equipment such as winch, hydraulic pump and cylinders, harness and blade, radiator guard, power take-off and control unit.

5.2.4.1 For pneumatic tyred tractors, the total static weight on any tyre shall not exceed the maximum recommended by the tyre manufacturer and the tyres shall be inflated in accordance with the load and pressure schedule of the tyre manufacturer.

5.2.5 No correction for atmospheric conditions shall be made to the results but the mean atmospheric temperature, pressure be recorded in the table of results.

5.2.6 The governor shall be in operation throughout the drawbar tests and the governor setting shall be such that the governed speed, when under a load corresponding to 85 percent of the maximum horsepower developed at rated speed, does not exceed the rated speed by more than BB export PDF v 10 percent. If the governor setting is such that the maximum power occurs within the range rated speed $\pm_{0}^{2.5}$ percent, then C in Table 1 and B in Table 2 may be omitted

5.2.7 The drawbar tests in all working gears for a tractor with a spark-ignition engine shall be made with the fuel settings normally supplied as standard. If optional rich mixture settings are recommended, a further test in the gear to be designated by the manufacturer shall be made to comment determine the maximum drawbar power (rich mixture).

5.2.8 In any test, curves of drawbar, horsepower/pull, track slip/pull or wheel slip/pull, forward ii Combine Files speed/pull, fuel consumption/pull and specific fuel consumption/pull shall be drawn for the full range of drawbar pulls obtainable in the gears designated by the tractor manufacturer. The maximum sustained pull shall also be recorded in each gear. Fuel consumption in litre per hour shall be measured by a volume/time method, an auxiliary fuel tank being used. The auxiliary tank shall be arranged so as to provide conditions of feed comparable with the normal system. In calculating specific fuel consumption, the observed values of fuel consumption and drawbar horsepower shall be used. Typical curves are shown in Fig. 2 to Fig. 4.

5.2.8.1 The specific fuel consumption values are reported as weight of fuel per hour per unit of work. To obtain values of the volume of fuel per hour and work per unit of volume, the conversion of units of weight to units of volume shall be made using the specific gravity of the fuel at 16°C.

When fuel consumption is measured by volume, the specific fuel consumption shall be calculated using the specific gravity of the fuel at the appropriate temperature.

5.2.9 The curves referred to in **5.2.8** shall be obtained from the results of a number of test runs at various drawbar loads in each gear. No time is laid down for the duration of each test run but it is envisaged that each run shall be made by travelling in both directions over a measured distance of 153 m, or for a minimum time of 3 minutes. Travelling speed shall be determined by timing the tractor over the test distance and fuel consumption readings shall be calculated from total fuel consumed by the tractor during each test run.

5.2.10 Track or wheel slip shall be measured by comparing the 'no-slip' distance with the distance travelled in making a given number of revolutions under load. The no-slip distance shall be taken to be the mean of the distance travelled at slow speed by the tracks or wheels in making the prescribed number of revolutions when the tractor is (a) running light, and (b) being towed. In each test, these measurements shall be the means obtained from runs in the opposite directions.

5.2.10.1 In the event of the design of the transmission rendering it impracticable to tow the tractor readily, the no-slip distance shall be taken as the distance travelled when running light.

5.2.11 A ten-hour test shall be carried out and shall consist of continuous operation under the load specified with not more than one stop of not more than five minutes for refueling. The drawbar load shall be such that 75 percent of the maximum drawbar power recorded during the test for maximum drawbar power, shall be developed at a pull of not less than 50 percent of the maximum sustained pull in the lowest gear.

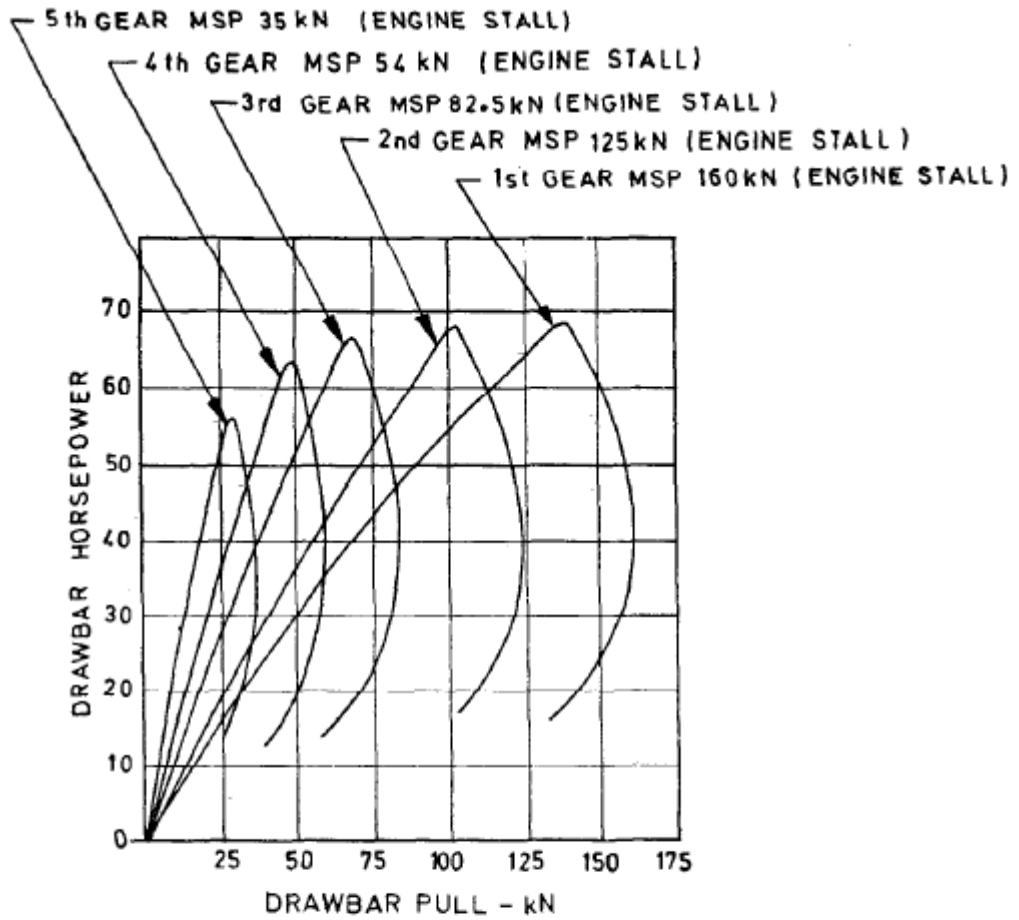

A - DRAWBAR HORSEPOWER/PULL

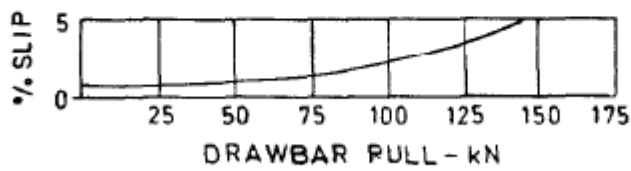

B - SLIP/PULL

FIG. 2 Drawbar Test Curves, Grassland on Heavy Clay

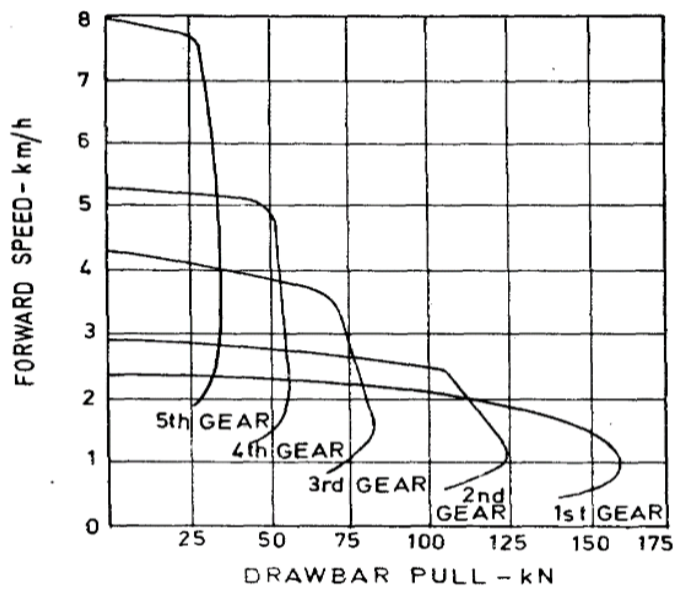
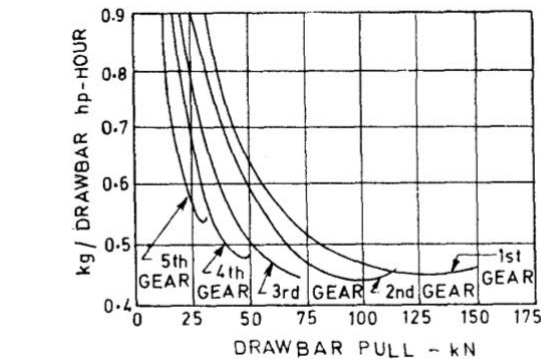
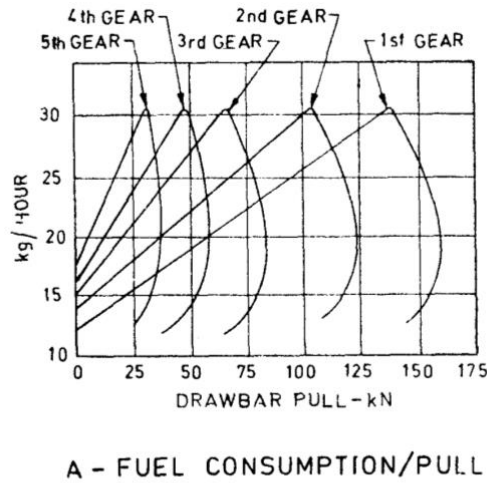

FIG. 3 DRAWBAR TEST CURVES FORWARD SPEED/PULL GRASSLAND ON HEAVY CLAY



B-SPECIFIC FUEL CONSUMPTION/PULL

FIG. 4 DRAWBAR TEST CURVES, GRASSLAND ON HEAVY CLAY

5.2.11.1 In case of spark-ignition engines fitted with rich mixture adjustment, the maximum drawbar power obtained with the rich mixture setting shall be used for calculating the load for this test. The ten-hour test shall be made with the normal mixture.

5.2.12 The results of the tests shall be presented in the form shown in Table 1 for a tractor fitted with a spark-ignition engine and in the form shown in Table 2 for a tractor fitted with a compression-ignition engine.

5.2.12.1 The requirements (a) to (e) in Tables 1 and 2 are for ease of reference and are not intended for inclusion in the final published test results.

5.3 Clearance Circle Test

For physical testing of a tractor to determine the clearance diameter, the procedure is as follows.

5.3.1 Check steering geometry alignment and correct, if necessary.

5.3.2 Check the front wheel cut angles to manufacturer's recommendations. Wheel stops shall be so set that the minimum clearance between the tyre and the nearest point of interference is 20 mm or, so that with the wheel stops in contact, a margin of a quarter turn of the steering wheel is left before the maximum travel of the steering gear is reached. In some cases, tyre interference will be the limiting factor and in others, the steering gear travel will limit the maximum cut angle.

5.3.3 Load the vehicle to the maximum recommended gross weight.

Table 1 Drawbar Tests (Tractor with Spark-Ignition Engine)

(Clauses 5.2.6, 5.2.12, and 5.2.12.1)

Rated engine speed =rev/min											
Gear	Horse Power	Drawbar Pull	Engine Speed	Speed	Slip of Tracks	Temperature			Atmospheric Conditions		
						Lubricating oil	Coolant	Fuel	Dry Bulb Temperature	Wet Bulb Temperature	Pressure
(1)	(2)	(3)	(4)	(5)	(6)	(7)	(8)	(9)	(10)	(11)	(12)
			N rev/min	km/h	percent	°C	°C	°C	°C	°C	mbar*
a) Maximum power (rich mixture)											
b) Maximum power (normal mixture)											
c) Power at rated enginespeed (normal mixture)											
d) Ten-hour test (normal mixture) at 75 percent of maximum drawbar power											
e) Fuel consumption and maximum sustained pull (MSP)											
Gear	Optimum Fuel Consumption		Range of Pull Over which Fuel Consumption is within 10 percent of Optimum	MSP	Factor Limiting MSP	Atmospheric Conditions					
	Drawbar hp hour/ litre	kg per Drawbar hp hour				Dry Bulb Temperature	Wet Bulb Temperature	Pressure			
(1)	(2)	(3)	(4)	(5)	(6)	(7)	(8)	(9)			
	Drawbar hp hour/ litre	kg per Drawbar hp hour	N	N		°C	°C	mbar*			
---	---	---	---	---	---	---	---	---			
---	---	---	---	---	---	---	---	---			
---	---	---	---	---	---	---	---	---			
---	---	---	---	---	---	---	---	---			

*1 mbar = 100 N/m² = 100 Pa.

Table 2 Drawbar Tests (Tractor with Compression- Ignition Engine)
(Clauses 5.2.6, 5.2.12 and 5.2.12.1)

Gear	Horse-power	Drawbar Pull	Engine Speed	Speed	Slip of Tracks	Temperature			Atmospheric Conditions		
						Lubricating oil	Coolant	Fuel	Dry Bulb Temperature	Wet Bulb Temperature	Pressure
(1)	(2)	(3)	(4)	(5)	(6)	(7)	(8)	(9)	(10)	(11)	(12)
		N	rev/min	km/h	percent	°C	°C	°C	°C	°C	mbar*

- a) Maximum power
- b) Power at rated engine speed
- c) Ten-hour test — at 75 percent of maximum drawbar power
- d) Fuel consumption and maximum sustained pull (MSP)

Gear	Optimum Fuel Consumption		Range of Pull Over which Fuel Consumption is within 10 Percent of Optimum	MSP	Factor Limiting MSP	Atmospheric Conditions		
	Drawbar hp hour/ litre	kg per Drawbar hp hour				Dry Bulb Temperature	Wet Bulb Temperature	Pressure
(1)	(2)	(3)	(4)	(5)	(6)	(7)	(8)	(9)
	Drawbar hp hour/ litre	kg per Drawbar hp hour	N	N		°C	°C	mbar*
...
...
...
...

*1 mbar = 100 N/m² = 100 Pa.

5.3.4 Run the vehicle on a dry, flat apron, making turns in both directions in low gear at engine idle speed. The wheels should be turned to the maximum cut angle. At least two complete circles shall be made before making measurements. The path of the outside wheel is marked on the pavement -by pouring water on the tyre while making the complete circle

5.3.5 To determine the turning diameter, measure from the midpoint of the contact trace on the pavement to a similar point across the diameter of the trace. Turning radius will be half this distance and the turning centre will be at the midpoint of the diameter.

5.3.6 To determine the clearance diameter, drop a plump line from the extreme outside radial extension of the vehicle and locate the point on the pavement directly beneath it. The distance

thence to the turning centre is the vehicle clearance radius, twice which is the clearance diameter. The clearance diameter thus obtained shall be within the limits recommended by the tractor manufacturer.

5.4 Static Tilting Tests

5.4.1 The fuel, coolant and all lubricating oil levels having been checked, the tractor engine shall be started and run at rated speed with the tractor tilted as follows:

- a) Longitudinally, nose up;
- b) Longitudinally, nose down;
- c) Laterally, offside up; and
- d) Laterally, offside down.

In each test, the engine shall be run till stabilization of coolant temperature, lubricating oil pressure and free from fuel starvation as stipulated by the engine manufacturer.

5.5 Brake Tests

Brakes shall be tested as per IS 9701.

5.6 Lifting Capability

The lifting capacity of hooks, eyes and members, if provided, shall be as per agreement between the manufacturer and the purchaser.

5.7 Speed Test

5.7.1 Run the tractor on a plain dry swept concrete or asphalt course, straight and level within 3 percent of grade.

5.7.2 Record the time taken for covering a marked distance of 50 metres after the tractor has achieved stabilized speed commensurate with gear and engine - giving maximum speed.

5.7.3 Take a minimum of three readings. Repeat trials for the case when the two readings differ by more than 20 percent. Record the average.

5.7.4 Compute the speed as follows:

$$\text{Speed} = 180/t \text{ km/h}$$

where t = time in seconds.

Computed speed shall be within ± 10 percent of the declared

5.8 Continuous Operation Test

5.8.1 The tractor with a towed load of maximum specified value, shall be driven over a smooth paved road at not less than 16 km/h or specified speed, whichever is less, for a period not less than four hours.

5.8.2 The use of a heavy trailer equipped with dual wheels and pneumatic tyres may be used for performing this test.

5.8.3 During this test, observe gauge for overheating, pressure gauges for low pressure, ammeter for low charging-rate and not unusual noises and operation deficiencies.

5.8.4 Observe for malfunction of the tractor or failure of any component during the test.

6 FINAL EXAMINATION AND TEST REPORT

6.1 At the conclusion of the tests, the tractor shall be dismantled in order to verify those items of the tractor specification referred to in **6.3(b)** below, which affect the performance.

6.2 The test report shall include the performance tables specified in **5.2.12**, the curves specified in **5.2.8** and also a section headed 'GENERAL REMARKS' under which the following information shall be given:

- a) A list of repairs and adjustments to the tractor found to be necessary during the tests;
- b) Any comments on particular features of the tractor or its behaviour which might adversely affect its practical performance;
- c) A note of the consumption of coolant and the maximum position of the radiator blind or shutters during the drawbar tests;
- d) A note of the consumption of lubricating oil during the drawbar tests; and
- e) A note of the values of the cohesive strength of the soil as determined by the method given in Annex A.

6.3 The test report shall include a section headed 'BRIEF SPECIFICATION' under which the following information, if applicable, shall be given:

- a) A specification of the fuel used during the test, stating the specific gravity at 16°C and the cetane number quoted by the manufacturer. The Indian name of the fuel used shall be given in the report. For tractors equipped with compression ignition engines, the fuel oil used throughout the test shall be as per IS 1460.
- b) A brief specification of the tractor on which tests were made. This will be the responsibility of the tractor manufacturer and those points which would affect the performance shall be verified by the testing authority in so far as essential factors are concerned. The brief specification shall include the following items where applicable.

1) *Tractor* - Size in terms of drawbar horsepower, type and serial number.

2) *Engine* - Make, serial number, number and disposition of cylinders, cycle, type of combustion, chamber, bore, stroke, cubic capacity and compression ratio, whether natural or blown aspiration, type and make of pressure-charger, valve arrangement, type of cylinder liners; type of governor, rated engine speed and governor speed range; fuel and ignition system including filters, type and make of injectors and injection pump; lubrication systems including filters and cooler, SAE viscosity number and type of lubricating oil; cooling system and means of temperature control, type of coolant method of starting; electrical equipment including battery voltage and capacity; capacities of fuel,

oil and cooling system; and if pressurized, type and make of carburettor, fuel pump, ignition system and air cleaner.

3) *Transmissions and Steering* - Type and make of clutch or coupling; type of gearbox and number of speeds; description of steering system; diameter of swept right and left hand turning circle with equipment in the normal travelling positions (if relevant); type of final drive; oil capacities of gearbox and final drives together with SAE viscosity number and type of lubricating oils.

4) *Power Take off Arrangements* - Description, number and disposition, power rating, speeds and direction of rotation, diameter and spline of each power take-off.

5) *Sprockets* - Pitch diameter, number of teeth and face width.

6) *Tracks* - height of Type, pitch, pin diameters; width of track-plates, attachment of grousers and grousers; gauge, approximate length of track in ground contact with full grouser penetration.

7) *Suspension* - Diameter of front idler, number and rolling diameters of track and carrier rollers, method of suspension and method of lubrication.

8) *Wheels* - Size, arrangement and type, number of driving wheels, method of wheel mounting; tyre sizes and type of tread, inflation pressures, amount and type of ballast; wheel track: wheel-base; type of brake and method of control.

9) *Drawbar* - Radius of swing, position of pivot centre relative to sprocket centres, laterai and vertical adjustment; height during test; note of standard specification with which positions of drawbar shaft are in accordance.

10) *Speeds* - In km per hour at rated engine speed in all forward and reverse gears.

11) *Equipment* - A list of the ancillary equipment with which the tractor is equipped when tested (*see 5.2.4*).

12) *Weight* - Total weight of tractor with operator, full fuel, oil and cooling system: both with equipment as tested and without equipment. In each case, horizontal distance of point of balance in front of rear sprocket or rear wheel centre to be given. The weight of any ballast shall be included.

13) *Dimensions* - Overall length, width and height of tractor and minimum ground clearance: both with equipment as tested, and without equipment. These dimensions shall be measured as follows:

- (i) Dozers shall be at right angles to the longitudinal axis of vehicle.
- (ii) Grader blades and crane booms shall be in the minimum travelling position,
- (iii) Loader buckets shall be in the ground position.
- (iv) Height of tractor shall be measured with the tractor on a level surface,
- (v) Minimum ground clearance shall be measured on a surface giving full rouser penetration.

All nomenclature definitions shall cover complete vehicle including any attached equipment.

6.4 The tables in the test report shall be followed by a footnote thus:

Tests are run with the governor in operation. The governor setting for engine and drawbar tests is such that the speed corresponding to 85 percent of the maximum power at the appropriate rated speed does not exceed that speed by more than 10 percent.

ANNEX A
(Clauses 5.2.1 and 6.2)

TORSIONAL SHEAR TEST

A-1 The apparatus consists of a cylindrical torsion box, 127 mm in diameter and 50.8 mm deep, with a removable lid, as shown in Fig. 5 and a torque meter which can be fitted in a square tube perpendicular to the lid. On the inside of the walls of the box are six equally spaced fins 50 mm long, 5 mm wide and 1 mm thick. The outside lower edge of the box is sharpened.

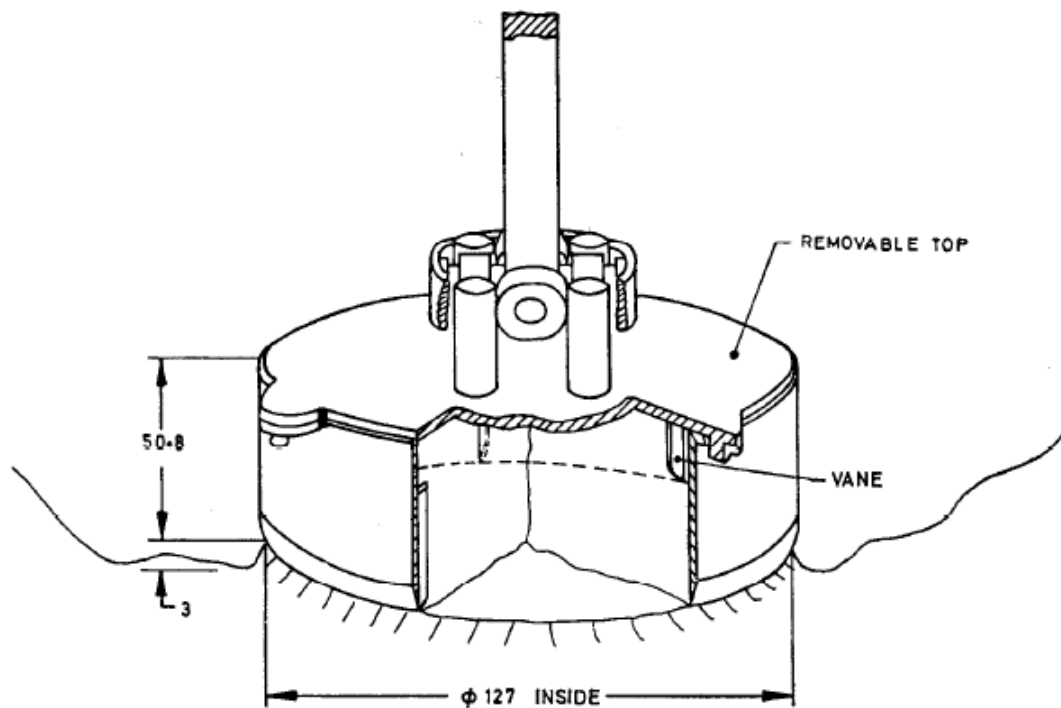

All dimensions in millimetres

FIG. 5 TORSIONAL SHEAR BOX
(Cut away to show Vanes and Soil within Box)

A-2 In use, the torsion box is forced into the soil to its full depth and the surrounding soil removed to leave the box, full of soil, standing on a very short column of soil about 3 mm high. A torque is then applied to the lid of the box and the value necessary to cause failure in a disc of soil at the bottom of the box is recorded. The shear strength of the soil is given by the formula:

$$S = \frac{3 M}{2 \pi r^3}$$

Where,

S = shear strength in bar

M = torque meter reading in NM, and

r = radius of box in M.

The value of shear strength with no vertical load applied to the box is called the cohesive strength.

A-3 The effect of normal loading on the shear plane on shear strength may be found by placing weights on the lid of the torsion box. It is possible to use the box with upto 45.4 kg on the lid in almost all soils.

A-4 For the purpose of recording the strength properties of soil in connection with tractor testing, it is recommended that a graph shall be plotted of shear strength against normal load, from the averages of at least three readings at each of four normal loadings (maximum at least 0.35 bar) and with zero normal load. The cohesion is the shear strength at zero normal load.

