

**BUREAU OF INDIAN STANDARDS**

DRAFT FOR COMMENTS ONLY

(Not to be reproduced without permission of BIS or used as an Indian Standard)

*Draft Indian Standard*

**SPECIFICATION FOR DIRECTION OF TRAVEL-CONTROLS FOR INDUSTRIAL  
TRACTORS AND POWERED INDUSTRIAL TRUCKS**

(ICS 43.040.70)

---

Transport Tractors, Trailers and Industrial Trucks  
Sectional Committee, TED 22

Last date for receipt of  
comments is 04/05/2022

---

## TED 22 (19045) P

Transport Tractors, Trailers and Industrial Trucks Sectional Committee, TED 22

### FOREWORD

*(Formal clause to be added later)*

The best controls are those which most closely agree with natural human instinct. Such controls are sometimes called ‘directional’ -where control movement is in the same direction as desired movement of truck or accessory. Some controls such as ‘forward’ and ‘reverse’ are obvious and easy to make ‘directional’.

Other control movements are less obviously ‘directional’ and call for a thorough study and/or testing to determine the most natural human reaction. Recommendations for preferred motions and placement of controls are intended to establish uniform practices in this area.

This standard is based on Doc : ISO/TC 110/SC 2(Sec-39) 104 (revised) ‘Direction of travel-controls’, issued by the International Organization for Standardization (ISO).

The composition of the committee responsible for formulation of this standard is given as Annex A. (Will be added later)

For the purpose of deciding whether a particular requirement of this standard is complied with, the final value, observed or calculated, expressing the result of a test or analysis, shall be rounded off in accordance with IS 2:1960 ‘Rules for rounding off numerical values (revised)’. The number of significant places retained in the rounded off value should be the same as that of the specified value in this standard.

*Draft Indian Standard***SPECIFICATION FOR DIRECTION OF TRAVEL-CONTROLS FOR INDUSTRIAL TRACTORS AND POWERED INDUSTRIAL TRUCKS****1 SCOPE**

**1.1** This standard covers direction of travel-control symbols for use on industrial tractors and various types of industrial trucks.

**2 REFERENCES**

The standards given below contain provisions which, through reference in this text, constitute provision of this standard. At the time of publication, the editions indicated were valid. All standards are subject to revision, and parties to agreements based on this standard are encouraged to investigate the possibility of applying the most recent editions of these standards.

| <i>IS No.</i> | <i>Title</i>   |
|---------------|--|
| IS 4660: 1993 | Powered industrial trucks - Terminology (Third Revision) |

**3 TERMINOLOGY**

**3.0** For the purpose of this standard, the terms and definitions as given in **IS: 4660-1974 IS 4660 : 1993** along with the following shall apply.

**3.1 Sit-On (Rider) Trucks** — Trucks where the operator operates the truck while sitting.

**3.2 Stand-On (Rider) Trucks** — Trucks where the operator operates the truck while standing.

**3.3 Central Control** — Operating controls provided at the centre of the truck.

**3.4 End Control** — Operating controls provided at the either end of the truck.

**3.5 Pedestrian Controlled Trucks** — Trucks where the operator walk along with the truck.

**4 FRONT END AND FORWARD DIRECTIONS OF TRAVEL**

**4.1 Front End of Trucks** — The front end of a truck is the end indicated by an arrow in the sketches given under **4.4**.

**4.2 Rear End, Left-Hand and Right-Hand Side of Trucks** — These are in conformity with the definition given in **4.1**.

**4.3 Forward Direction of Travel** — The forward direction of travel is when the truck travels in the direction indicated by the arrow.

#### 4.4 Nomenclature of Trucks

##### 4.4.1 *Sit-On (Rider) Trucks*

**4.4.1.1** Trucks where the load is leading when the truck travels in the forward direction as given below:

- a) Counterbalanced forklift truck (*see* Fig. 1).
- b) Straddle or reach (with retractable mast or fork) truck (*see* Fig. 2).
- c) Shunting tractor (*see* Fig. 3).

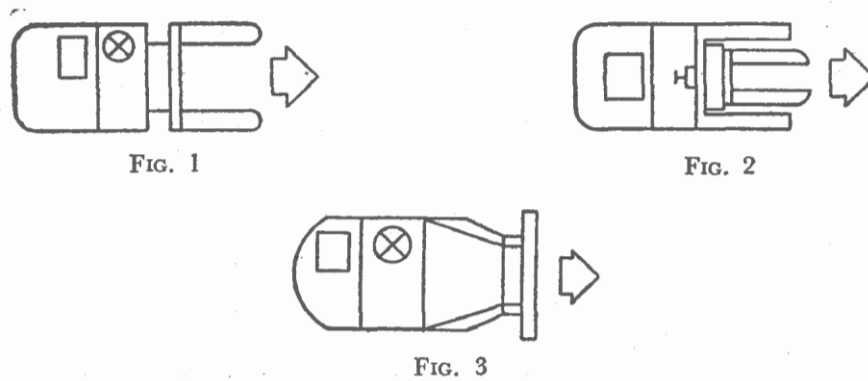

**4.4.1.2** Trucks where the load is trailing when the truck travels in the forward direction as given below:

- a) Straddle or reach (with retractable mast or fork) truck where the driver is seated sideways (*see* Fig. 4).
- b) Towing tractor-front end control (*see* Fig. 5).
- c) Towing tractor-rear end control (*see* Fig. 6).
- d) Fixed or elevating platform truck (*see* Fig. 7)

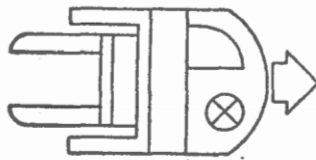

FIG. 4

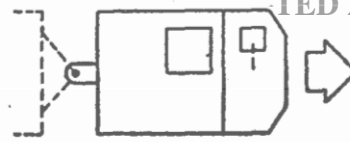

FIG. 5

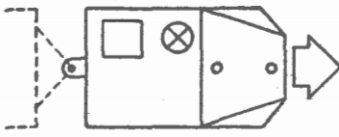

FIG. 6

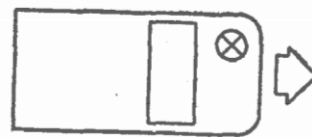

FIG. 7

#### 4.4.2 Stand- On Trucks

**4.4.2.1 Centre control** — Trucks where the load is leading when the truck travels in the forward direction as given below:

a) Counterbalanced forklift truck (*see* Fig. 8).

#### 4.4.2.2 End control

a) Trucks where the load is leading when the truck travels in the forward direction as given below:

1) Counterbalanced forklift truck (*see* Fig. 9).

2) Straddle or reach (with retractable mast or fork) truck (*see* Fig. 10).

b) Trucks where the load is trailing when the truck travels in the forward direction as given below:

1) Straddle or reach truck (with retractable-mast or fork) with driver standing sideways (*see* Fig. 11).

2) Fixed or elevating platform truck (*see* Fig. 12).

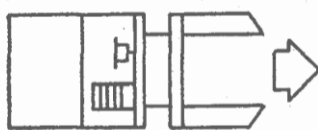

FIG. 8

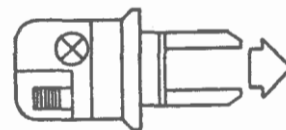

FIG. 9



FIG. 10



FIG. 11

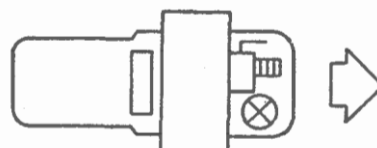

FIG. 12

**4.4.3 Pedestrian Controlled Trucks** — Trucks where the load is trailing when the truck travels in the forward direction as given below:

- a) Pallet truck, (*see* Fig. 13).
- b) Fixed or elevating platform truck (*see* Fig. 14).
- c) Counterbalanced forklift truck (*see* Fig. 15).
- d) Tractor (*see* Fig. 16).



FIG. 13



FIG. 14

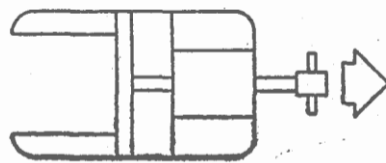

FIG. 15



FIG. 16

## 5 STEERING CONTROLS

### 5.1 Steering Sit-on (Rider) Trucks

**5.1.1** All steering controls shall be confined within the plan view outline of the truck, or guarded to prevent injury to the operator during movement of the controls when passing obstacles, walls, columns, etc.

**5.1.2** Where steering is required to be accomplished with one hand, steering knobs are necessary for safe operation. Steering knobs, when used, shall be mounted within the periphery of the steering hand wheel, and provision shall be made to prevent injury to the operator's hand.

### 5.2 Steering Wheels

**5.2.1** On all trucks, where the operator faces in the normal line of travel, which are steered by means of steering wheels (horizontal, inclined or vertical); a clockwise rotation of the steering wheel shall steer the truck to the right in the forward direction of travel<sup>D</sup> (*see* Fig. 17A and 17B).

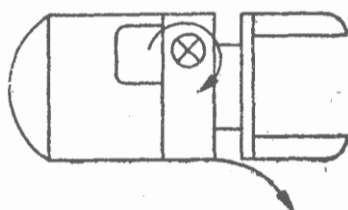

FIG. 17A

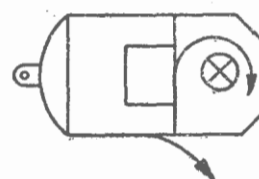
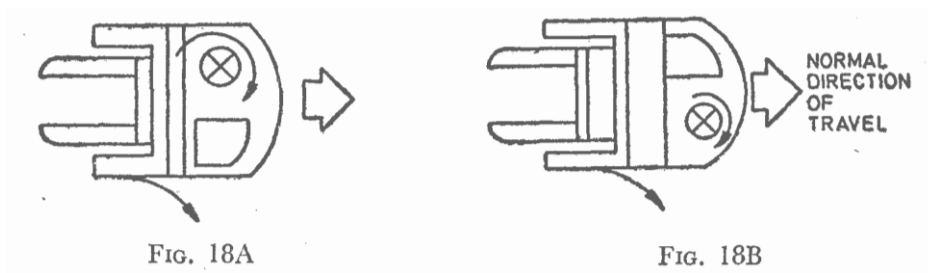

FIG. 17B

**5.2.2** On all trucks where the operator faces at a right angle to the normal direction, of travel which are steered by means of a steering wheel (horizontal, inclined or vertical); a clockwise rotation of the steering wheel shall steer the truck clockwise when the truck is travelling with the load trailing<sup>D</sup> (see Fig. 18A and 18B).



### 5.3 Tillers

**5.3.1** *Tillers Operating in a Horizontal Plane* — On trucks steered by a tiller moving in the horizontal plane and which in the neutral position is parallel to the longitudinal axis of the truck, or steered by a tiller rotating on a shaft parallel to the longitudinal axis of the truck and which in the neutral position stands upright (see Fig. 19A).

**5.3.1.1** When the driver is facing in the direction of travel, movement of the tiller to his right shall steer the truck to his right (see Fig. 19B).

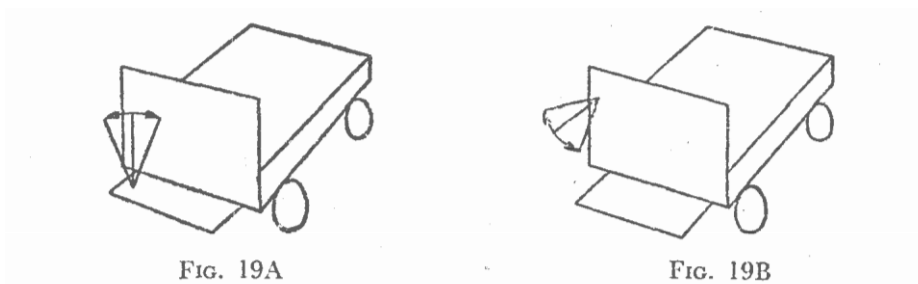

**5.3.2** *Tillers Operating in a Vertical Plane* — On stand-on lift platform trucks [see 4.4.2.2 (b)] and fixed platform trucks which are steered by means of a tiller situated on the right of the driver and operating in a vertical plane, raising the tiller (clockwise rotating shall steer the truck to the right) in the forward direction of travel<sup>D</sup> (see Fig. 20).

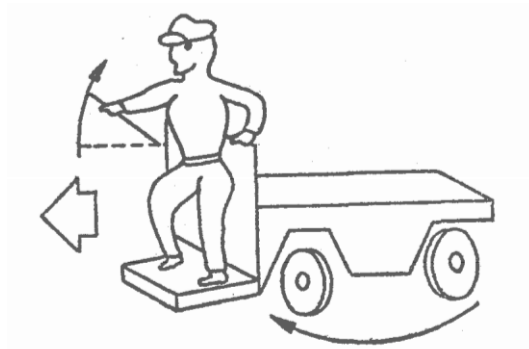

FIG. 20

NOTE — **D** Considerable numbers of trucks of models given under 4.4.1.2 and 4.4.2.2 have been built with a steering reverse of the above standard. Such trucks may still be manufactured, provided that on the truck an arrow indicates in which direction the steering control shall be moved to steer the truck to the right in the forward direction of travel.

#### 5.4 Steering Handle - Motorized Hand/Rider Trucks

5.4.1 Steering handle shall be provided with suitable means to protect operator's hands against injury from swinging doors, walls, columns, etc.

5.4.2 Motorized hand/rider trucks employing a steering tongue control which extends beyond the confines of the truck shall steer as follows:

a) With the walking operator facing in the direction of travel, with load trailing, clockwise movement of the steering tongue shall steer the truck clockwise; and

b) With the riding operator facing in the direction of travel, with the load trailing, clockwise movement of the steering tongue shall steer the truck clockwise.

5.5 Pivoting Steering Controls — On trucks which are steered by means of a pivoting control operated by foot (*see* Fig. 21), or by hand (*see* Fig. 22), a clockwise rotation of this control, looking in the forward direction of travel, shall steer the truck to the right.

### 6 DRIVING AND BRAKING CONTROLS

#### 6.1 Sit-Down Rider Trucks

6.1.1 *Pedals Arrangement* — The accelerator, brake and clutch pedals (when fitted) of internal combustion engine and electric powered trucks shall be arranged according to Fig. 23A and 23B respectively.



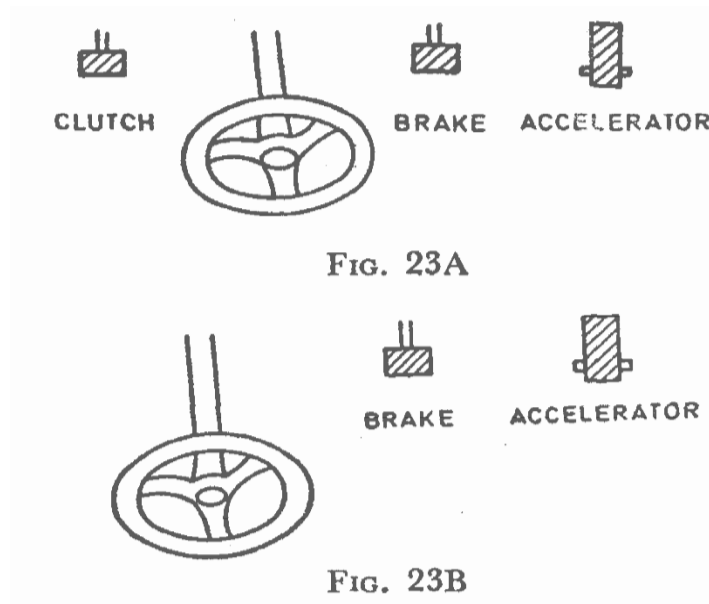
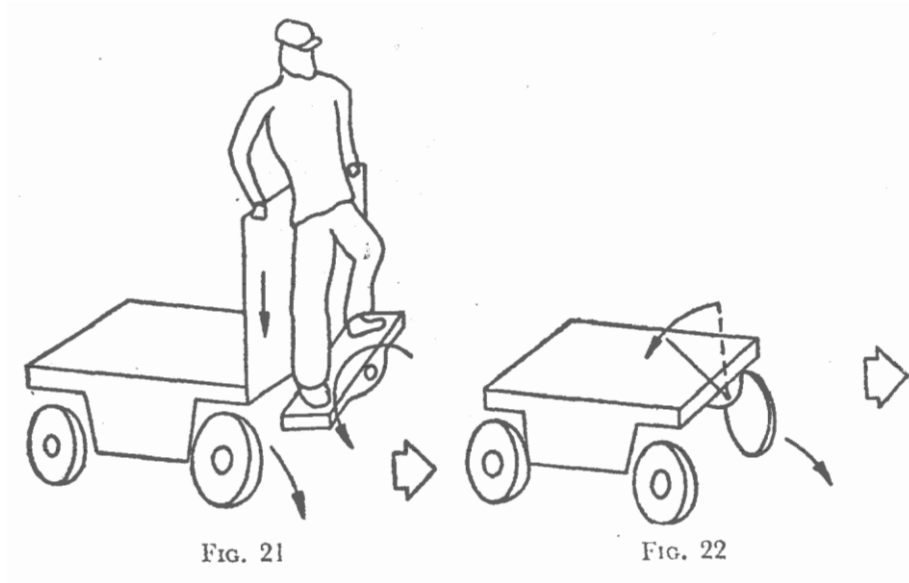

**6.1.1.1** Where the pedal control system differs from Fig. 23A and 23B, its function shall be clearly indicated both in the driving instructions and on truck itself.

**6.1.2** *Gear Change Lever* — The positions for gear engagement shall be clearly indicated.

**6.1.3** *Direction Change Levers* —The direction control levers on interna combustion engined trucks and the controller levers on electric trucks shall be arranged in such a way that their operation corresponds to the required direction of travel (*see* Fig. 24).

**6.1.4** *Safety Control and Brakes* — Electric Powered Industrial Trucks-Means shall be provided to open the travel circuit when the operator leaves the truck.

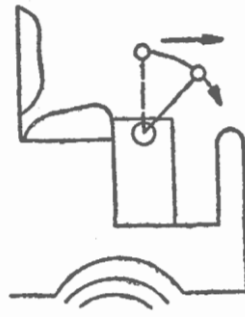

FIG. 24

**6.1.4.1** Travel control having a neutral position in the direction control shall be so arranged that the truck moves only when the direction control is actuated and shall not move at a speed greater than inching speed unless control has been actuated for both speed and direction. Where no neutral position is provided, the truck shall not move unless the speed control is activated.

**6.1.4.2** Accelerator, if foot operated, shall increase speed when depressed with the right foot.

**6.1.4.3** Service brakes, if foot operated, shall be energized by depressing the control by the right foot. Where the pedal control system differs from this, its function shall be clearly indicated both in the driving instructions and on the truck itself.

**6.1.4.4** If a single pedal controls both acceleration and braking, depressing pedal shall increase speed and releasing pedal shall apply brakes, when the pedal is being operated by the right foot.

**6.1.4.5** The parking brake (or mechanism) shall be manually or automatically applied and shall remain applied until released by the operator.

**6.1.5** *Safety Control and Brakes* — Internal Combustion Engine Powered Industrial Trucks — Travel control, having a neutral position in the direction control shall be so arranged that the truck moves only when the direction control actuated and shall not move at a speed greater than inching speed, unless, control has been actuated for both speed and direction. Where no neutral position is provided, the truck shall not move unless the speed control is activated.

**6.1.5.1** Service brakes, if foot operated, shall be energized by depressing the control.

**6.1.5.2** If a combination clutch and brake pedal is used, the initial pedal movement shall disengage the clutch and the final pedal movement shall apply the brakes and the pedal shall be operated by the left foot.

**6.1.5.3** Accelerator, if foot operated, shall increase speed when depressed with the right foot.

**6.1.5.4** If a combination pedal controls both acceleration and brakes depressing the accelerator portion shall increase speed and depressing the brake portion shall apply the brakes, and the combination pedal shall be operated by the right foot.

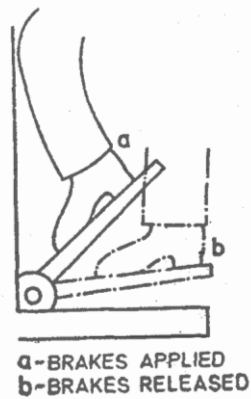

FIG. 25

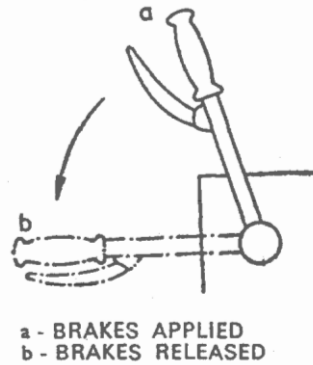

FIG. 26

**6.1.5.5** Clutch pedal, if used, shall release clutch by depressing with left foot.

**6.1.5.6** The parking brake (or mechanism) shall be manually or automatically applied and shall remain applied until released by the operator.

## **6.2 Stand-On (Rider) Trucks**

**6.2.1 Pedals** — When the truck is in motion, operator's foot shall remain on the pedal and by releasing the pedal, the brakes are applied (*see* Fig. 25).

**6.2.2 Levers** — The provisions of **6.1.2** and **6.1.3** shall also apply to stand-on trucks.

**6.2.2.1** Where a lever is provided, depressing the lever shall release the brakes. When the truck is in motion, operator's hand shall remain on the lever. Releasing the lever shall apply the brakes (*see* Fig. 26).

## TED 22 (19045) P

### 6.2.3 *Push-Buttons*

**6.2.3.1** When direction of travel is selected by push-buttons arranged vertically one above the other, pressing the upper button shall drive the truck in the forward direction of travel as defined in 4.3 (see Fig. 27).

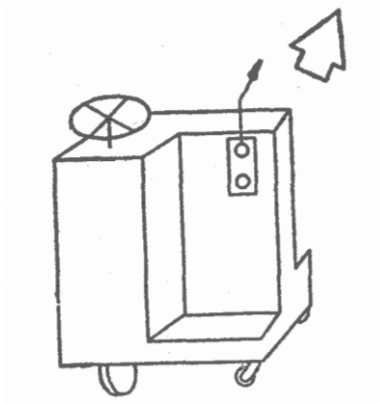

**6.2.3.2** When direction of travel is selected by push-buttons arranged horizontally, the direction controlled by each button shall be clearly indicated.

**6.2.3.3** All direction control, push-buttons shall return to neutral position when released.

### 6.2.4 *Safety Control and Brakes — Electric Powered Industrial Trucks*

**6.2.4.1** Means shall be provided to automatically open the travel circuit when the parking brake (or mechanism) is applied.

**6.2.4.2** Means shall be provided so that the travel circuit may be activated only by releasing the parking brake and resetting the speed and/or direction control(s) when the operator assumes the driving position.

**6.2.4.3** The parking brake (or mechanism) shall be manually or automatically applied and shall remain applied until released by the operator.

**6.2.4.4** Means shall be provided for mechanical or electrical interlocking for the forward and reverse motion.

### 6.2.5 *Safety Control and Brakes — Internal Combustion Engine Powered Industrial Trucks*

**6.2.5.1** Accelerator, if foot operated, shall increase speed when depressed with the right foot.

**6.2.5.2** Travel control shall be so arranged that the truck does not move until the direction control has been actuated and shall not move, at a speed greater than inching speed, unless control has been actuated for both speed and direction.

**6.2.5.3** The parking mechanism shall be manually or automatically applied. It shall remain applied until released by the operator.

### 6.3 Pedestrian Controlled Trucks

**6.3.1 Electric Trucks**— Forward and reverse motion of the truck shall be controlled or selected by means of a control device readily accessible when grasping handle grip on steering tongue. This control device shall operate directionally in one of the following manners:

- a) The control shall have a forward motion for forward travel and a rearward motion for reverse travel; or
- b) The control shall consist of two buttons located at top of control handle when steering tongue is approximately vertically arranged so that the forward one is for forward travel and vice-versa (*see Fig. 28*); or
- c) The control shall have rotary motion, the rotation being in the same direction as drive wheel rotation (*see Fig. 29A*).

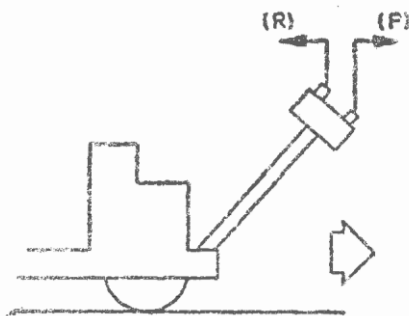

FIG. 28

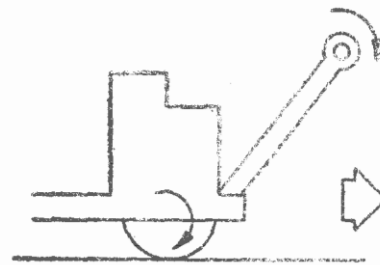
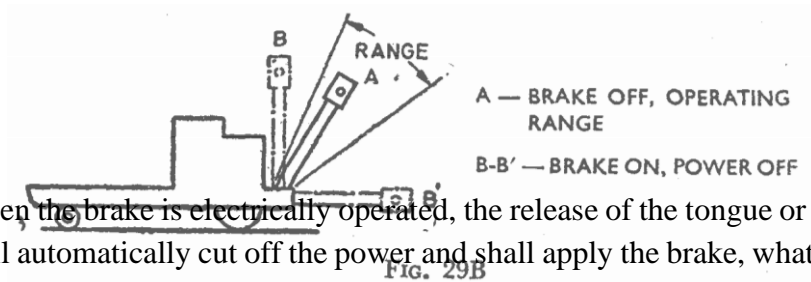

FIG. 29A

**6.3.1.2** The travel control shall be clearly and durably identified to indicate the function and direction of motion.

6.3.1.3 On electric trucks, the tongue shall be movable in a vertical plane. When the brake is mechanically operated in the vertical (B) and horizontal (B') positions, the brake shall be applied and the power switched off, unless it has already been switched off by the operation of the travel control switch (see Fig. 29B).



6.3.1.4 When the brake is electrically operated, the release of the tongue or of the travel control switch shall automatically cut off the power and shall apply the brake, whatever be the position of the handle.

NOTE — The requirements of 6.3.1.3 do not preclude controlled 'free-wheeling' when the power is off.

6.3.2 Internal Combustion Engine Powered Trucks — The tiller shall be movable in vertical plane. When the brake is operated in vertical (B) and horizontal (B') positions, the brake shall be applied and the power switched off, unless it has already been switched off by the operation of the travel control switch or clutch (see Fig. 30).

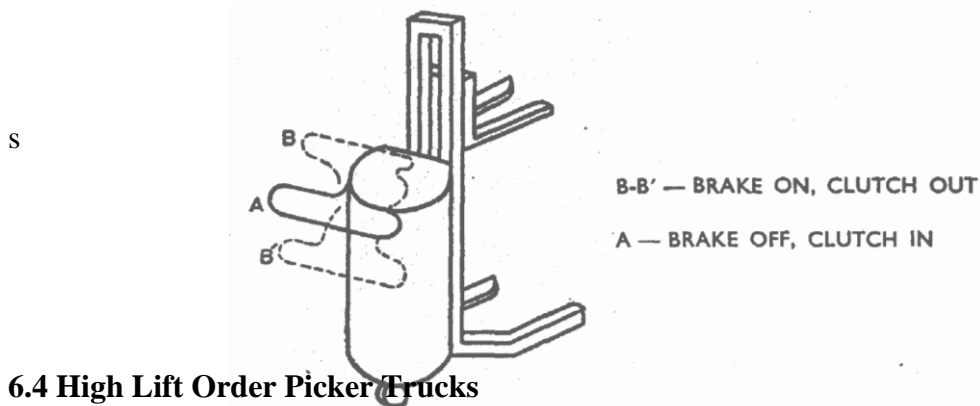

FIG. 30

### 6.4 High Lift Order Picker Trucks

#### 6.4.1 Safe & Control and Brakes

6.4.1.1 Controls shall be provided which de-activate travel controls when the operator leaves the truck.

6.4.1.2 Means shall be provided to render inoperative all operating controls other than those on the elevatable platform when the controls on the elevatable platform have been selected for use. Only one location of controls shall be capable of being operated at one time.

**6.4.1.3** Means shall be provided for an operator on the elevatable platform to shut off the power to the truck.

**6.4.1.4** Travel controls shall be so arranged that the truck may move only when the direction and speed controls have been actuated. Travel speed shall be such that at all operating platform heights the stability requirements of the relevant Indian Standards are complied with.

**6.4.1.5** The parking mechanism shall be manually or automatically applied and shall remain applied until released by the operator.

## **7 CONTROLS FOR THE MOVEMENT OF LOADS**

### **7.1 Control by Levers<sup>2)</sup>**

**7.1.1 Location** — The levers shall preferably be located so as to be operated by the driver's right hand, and clearly separated from the drive controls.

**7.1.1.1** Control symbols shall be applied on or in close proximity to the control levers.

#### **7.1.2 Vertical Levers<sup>2)</sup>**

**7.1.2.1** When the control levers are operated in a vertical plane the nearest to the driver (A) shall be for lifting and lowering the load, the next one (B) for tilting the load forward and backward. Other lever (C), if necessary, shall be used for controlling auxiliary devices (*see* Fig. 3 I).

**7.1.2.2** In the event of a single lever and gate being used, its sequence of operation shall be as indicated in **7.1.2.1**.

**7.1.2.3** On fork trucks with retractable mast or fork, the second lever (B') shall be used for the displacement of the mast or fork. The third lever (B) shall be used for tilting if provided and the other (C) for auxiliary devices (*see* Fig. 32).

NOTE — <sup>2)</sup> If it is not possible to comply with the requirements of **7.1.1** to **7.1.4**, the function and mode of operation of the levers shall be clearly indicated.

#### **7.1.3 Horizontal Levers<sup>2)</sup>**

## TED 22 (19045) P

**7.1.3.1** When the control levers are operated in a horizontal plane (under the steering wheel, for instance), the highest (A) shall be for lifting and lowering the load, that immediately below (B) for tilting mast, and the other under this (C) for controlling auxiliary devices (*see* Fig. 33).

**7.1.3.2** In the event of a single lever and gate being used, its sequence of operation shall be as indicated in **7.1.3.1**.

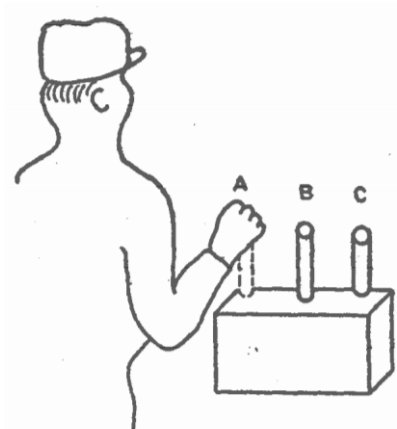

FIG. 31

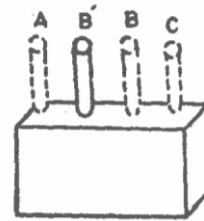

FIG. 32

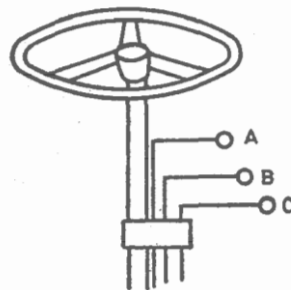

FIG. 33

**7.1.3.3** On fork trucks with retractable mast or fork, the second lever (B') shall be used for the displacement of the mast or fork. The third lever (B) shall be used for tilting if provided and the other (C) for auxiliary devices (*see* Fig. 34).

### 7.1.4 Movement<sup>2)</sup>

**7.1.4.1** In the case of levers located as prescribed in **7.1.2** and **7.1.3**, lifting shall be effected by pulling the lever (A) and lowering by pushing it. Backward tilt shall be effected by pulling the lever (B) and forward tilt by pushing it (*see* Fig. 35).

NOTE — <sup>2)</sup> If it is not possible to comply with the requirements of **7.1.1** to **7.1.4**, the function and mode of operation of the levers shall be clearly indicated.

**7.1.4.2** In the case of a single lever located under the steering wheel, and working in a 'type-selector gate' its operation in the vertical plane shall be for lifting [up (H) for lifting and down



(II) for lowering] and in the horizontal plane for tilting [pull (E) for backward and push (F) for forward tilting] (see Fig. 36).

7.1.4.3 On fork trucks with retractable mast or fork, retracting shall be effected by pulling the lever (B') and extending by pushing it (see Fig. 37).

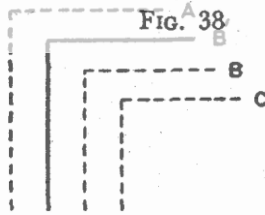
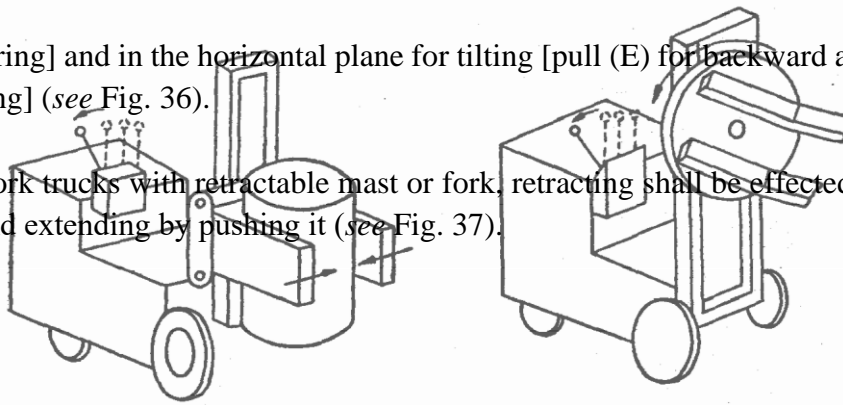

FIG. 34

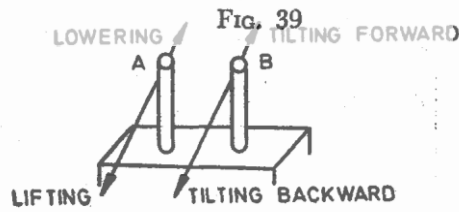

FIG. 35

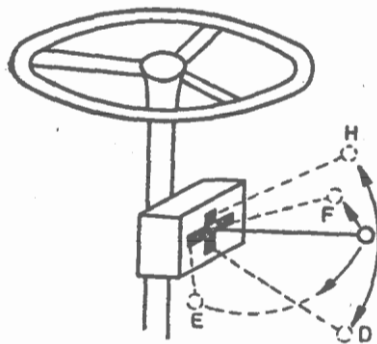

FIG. 36

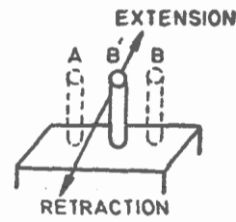

FIG. 37

7.1.5 Auxiliary Devices — The operation of control lever devices shall be as far as possible instinctive as explained below:

Examples:

- 1) Clamps — Pull lever to close arms, push lever to open arms (see Fig. 38).
- 2) Rotating Hand — Pull lever to see the head rotate clockwise, push lever to see it rotate anti-clockwise (see Fig. 39).
- 3) Tipping Scoop — Pull lever to return scoop, push lever to tip scoop (see Fig. 40).
- 4) Side-Shifter — Pull lever to see fork shift to the right of the driver (see Fig. 41).

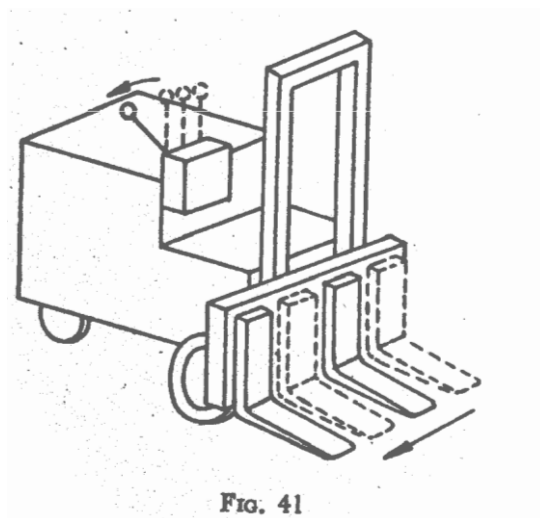

FIG. 41

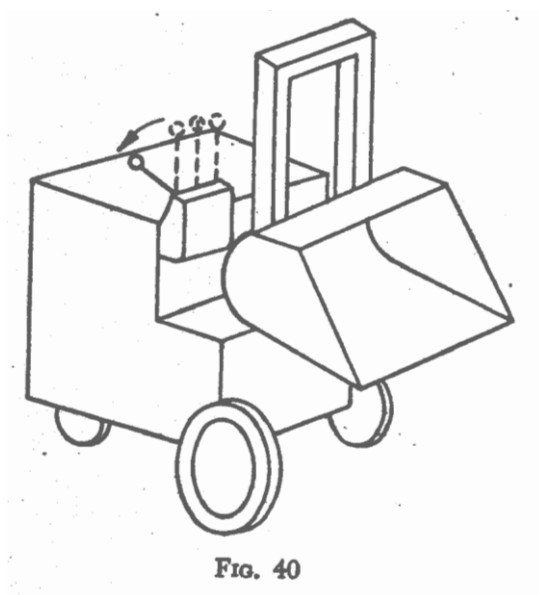

FIG. 40

**7.1.6 Identification** — When there are several levers, each lever shall be clearly and durably marked to indicate the individual function.

**7.1.7 Self-Centring** — All levers shall be self-centring.

**7.2 Control by Push Buttons** — Where the operation of lifting, lowering, tilting and auxiliary devices is controlled by push-buttons, these shall be arranged in such a way that they may be operated by the hand which is not being used to operate the steering control. The function of each button shall be clearly and durably indicated.

**7.2.1** Where the operation of lifting, lowering, tilting and/or auxiliary devices is controlled by a pair of push-buttons, they shall operate in the same sense as described in 6.2 For example, actuation of the button that is located to the rear relative to the operator's position) shall serve the same function as motion of a control lever to the rear.

**7.3 Rotary Controls** — The upper surface of a rotary control device shall move in the same sense direction as levers.

**7.4 Special Controls** — Special controls (such as for pre selective or automatic devices) shall be identified easily and shall preferably be in accordance with the above recommendations