

---

---

**Assistive products for walking  
manipulated by one arm — Requirements  
and test methods —**

**Part 1:  
Elbow crutches**

*Produits d'assistance à la marche manipulés avec un bras —  
Exigences et méthodes d'essai —*

*Partie 1: Cannes à appui antibrachial*



**PDF disclaimer**

This PDF file may contain embedded typefaces. In accordance with Adobe's licensing policy, this file may be printed or viewed but shall not be edited unless the typefaces which are embedded are licensed to and installed on the computer performing the editing. In downloading this file, parties accept therein the responsibility of not infringing Adobe's licensing policy. The ISO Central Secretariat accepts no liability in this area.

Adobe is a trademark of Adobe Systems Incorporated.

Details of the software products used to create this PDF file can be found in the General Info relative to the file; the PDF-creation parameters were optimized for printing. Every care has been taken to ensure that the file is suitable for use by ISO member bodies. In the unlikely event that a problem relating to it is found, please inform the Central Secretariat at the address given below.

© ISO 2007

All rights reserved. Unless otherwise specified, no part of this publication may be reproduced or utilized in any form or by any means, electronic or mechanical, including photocopying and microfilm, without permission in writing from either ISO at the address below or ISO's member body in the country of the requester.

ISO copyright office  
Case postale 56 • CH-1211 Geneva 20  
Tel. + 41 22 749 01 11  
Fax + 41 22 749 09 47  
E-mail [copyright@iso.org](mailto:copyright@iso.org)  
Web [www.iso.org](http://www.iso.org)

Published in Switzerland

# Contents

Page

Foreword.....	iv
<b>1 Scope .....</b>	<b>1</b>
<b>2 Normative references .....</b>	<b>1</b>
<b>3 Terms and definitions.....</b>	<b>1</b>
<b>4 Requirements .....</b>	<b>6</b>
4.1 Cuff.....	6
4.2 Handgrip .....	6
4.3 Leg section and tip .....	6
4.4 Adjusting devices .....	6
4.5 Materials .....	6
4.6 Mechanical durability .....	7
<b>5 Test methods.....</b>	<b>7</b>
5.1 General.....	7
5.2 Testing environment.....	7
5.3 Sampling.....	7
5.4 Forearm withdrawal test .....	7
5.5 Separation tests .....	8
5.6 Static loading test.....	10
5.7 Fatigue test.....	12
5.8 Low temperature falling test.....	12
5.9 Final inspection.....	12
<b>6 Information supplied by the manufacturer .....</b>	<b>12</b>
6.1 General.....	12
6.2 Information marked on the product.....	13
6.3 Documentation.....	13
<b>7 Test report .....</b>	<b>14</b>
<b>Annex A (informative) Recommendations .....</b>	<b>15</b>
<b>Bibliography .....</b>	<b>17</b>

## Foreword

ISO (the International Organization for Standardization) is a worldwide federation of national standards bodies (ISO member bodies). The work of preparing International Standards is normally carried out through ISO technical committees. Each member body interested in a subject for which a technical committee has been established has the right to be represented on that committee. International organizations, governmental and non-governmental, in liaison with ISO, also take part in the work. ISO collaborates closely with the International Electrotechnical Commission (IEC) on all matters of electrotechnical standardization.

International Standards are drafted in accordance with the rules given in the ISO/IEC Directives, Part 2.

The main task of technical committees is to prepare International Standards. Draft International Standards adopted by the technical committees are circulated to the member bodies for voting. Publication as an International Standard requires approval by at least 75 % of the member bodies casting a vote.

Attention is drawn to the possibility that some of the elements of this document may be the subject of patent rights. ISO shall not be held responsible for identifying any or all such patent rights.

ISO 11334-1 was prepared by Technical Committee ISO/TC 173, *Assistive products for persons with disability*.

This second edition cancels and replaces the first edition (ISO 11334-1:1994), which has been technically revised.

ISO 11334 consists of the following parts, under the general title *Assistive products for walking manipulated by one arm — Requirements and test methods*:

- *Part 1: Elbow crutches*
- *Part 4: Walking sticks with three or more legs*

# Assistive products for walking manipulated by one arm — Requirements and test methods —

## Part 1: Elbow crutches

### 1 Scope

This part of ISO 11334 specifies requirements and test methods for elbow crutches fully equipped with handgrip and tip. The methods specify testing of separation, static load capacity, fatigue and resistance to low temperature embrittlement.

This part of ISO 11334 also gives the requirements relating to safety, ergonomics, performance, and information to be supplied by the manufacturer, including marking and labelling.

The requirements and tests are based on every-day usage of elbow crutches when performing the through-swing gait, for a maximum user mass as specified by the manufacturer. This part of ISO 11334 is applicable to elbow crutches specified for a user mass of not less than 35 kg.

Requirements and test methods for friction of rubber tips against the walking surface are dealt with separately.

NOTE The recommendations given in Annex A supplement the requirements given in this part of ISO 11334.

### 2 Normative references

The following referenced documents are indispensable for the application of this document. For dated references, only the edition cited applies. For undated references, the latest edition of the referenced document (including any amendments) applies.

ISO 9999, *Assistive products for persons with disabilities — Classification and terminology*

EN 1041, *Information supplied by the manufacturer with medical devices*

### 3 Terms and definitions

For the purpose of this document, the following terms and definitions apply.

#### 3.1

##### **elbow crutch**

assistive product for walking with one leg, a handle and a non-horizontal forearm support

See Figure 1.

NOTE Classification no. 12 03 06, according to ISO 9999.

- 3.2 handle**  
part of the crutch to which the handgrip is attached
- 3.3 handgrip**  
part of the crutch which is intended by the manufacturer to be held by the hand when the crutch is in use  
See Figure 1, item 5.
- 3.4 handgrip length**  
*h*  
dimension of the handgrip measured longitudinally where the hand rests, starting at the lowest point as near as possible to the front stop of the handgrip, and ending at the point as near as possible to the rear stop and at the shortest possible distance from the tip  
See Figures 1 and 2.  
NOTE If there is no rear stop, the maximum handgrip length is 110 mm.
- 3.5 front handgrip reference point**  
lowest point next to the front stop where the handgrip length starts  
See Figure 1, item 7 and Figure 2, item 6.
- 3.6 rear handgrip reference point**  
point next to the rear stop where the handgrip length stops  
See Figure 1, item 8 and Figure 2, item 7.
- 3.7 handgrip support line**  
line drawn through the front and the rear handgrip reference points  
See Figure 1, item 6 and Figure 2, item 4.
- 3.8 handgrip width**  
width of the handle measured horizontally at the thickest part of the handgrip where the hand rests  
See Figure 2, item 5.
- 3.9 datum**  
point on the upper surface of the handgrip measuring one-third of the length from the rear handgrip reference point  
See Figure 2, item 3.
- 3.10 arm section**  
part of the crutch which is above the rear handgrip reference point
- 3.11 leg section**  
part of the crutch which is below the rear handgrip reference point

**3.12****cuff**

forearm support as used on an elbow crutch to hold the forearm in the correct position and prevent sideways movement

See Figure 1, item 2.

**3.13****cuff support line**

line drawn from the rear handgrip reference point and touching the inside rear bottom face of the cuff at maximum extension of the arm section

See Figure 1, item 1 and Figure 2, item 1.

**3.14****cuff internal width**

*y*

maximum internal dimension of the cuff measured left to right

See Figure 3.

**3.15****cuff internal depth**

*x*

internal dimension of the cuff measured front to back

See Figure 3.

**3.16****cuff internal height**

*z*

inside measurement of the cuff which is approximately parallel to the cuff support line and which supports the forearm

See Figure 2.

**3.17****tip**

part of the crutch which is in contact with the ground

See Figure 1, item 3.

**3.18****leg section axis**

line drawn from the rear handgrip reference point and through the centre of the tip at maximum extension of the leg section

See Figure 1, item 4.

**3.19****arm section length**

*a*

distance measured between the rear handgrip reference point and the highest point where the cuff support line touches the inside rear face of the cuff

See Figure 1.

**3.20**  
**leg section length**

*l*  
distance measured between the rear handgrip reference point and the centre of the bottom of the tip

See Figure 1.

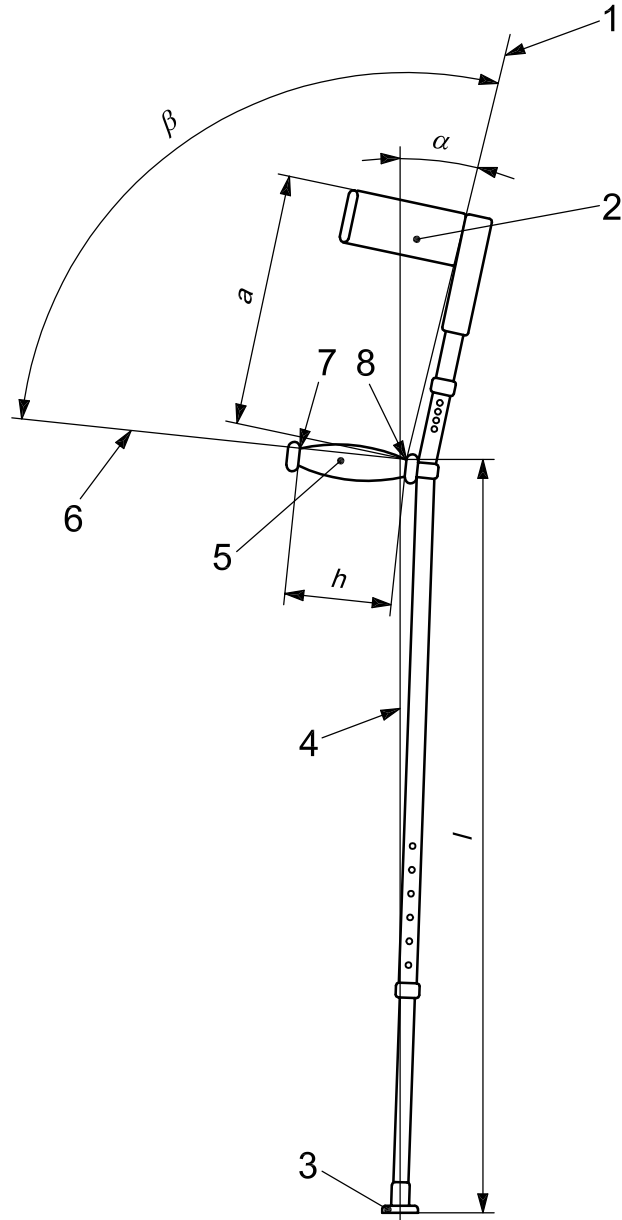

**Key**

- |   |                       |          |                                |
|---|-----------------------|----------|--------------------------------|
| 1 | cuff support line     | 7        | front handgrip reference point |
| 2 | cuff                  | 8        | rear handgrip reference point  |
| 3 | tip                   | <i>a</i> | arm section length             |
| 4 | leg section axis      | <i>h</i> | handgrip length                |
| 5 | handgrip              | <i>l</i> | leg section length             |
| 6 | handgrip support line | $\alpha$ | support angle                  |
|   |                       | $\beta$  | grip angle                     |

**Figure 1 — Example of an elbow crutch**



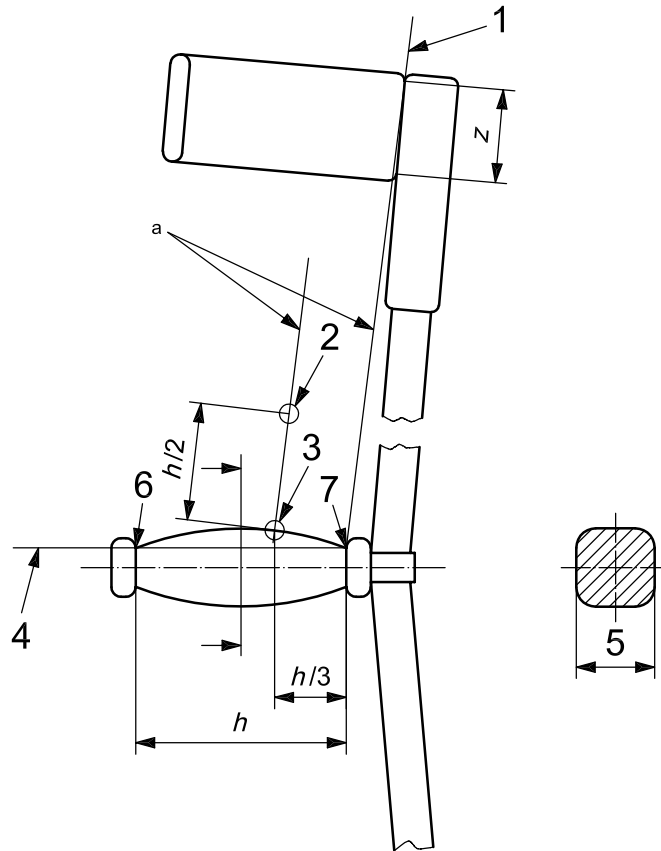

**Key**

- |   |                       |     |                                |
|---|-----------------------|-----|--------------------------------|
| 1 | cuff support line     | 6   | front handgrip reference point |
| 2 | wrist hinge point     | 7   | rear handgrip reference point  |
| 3 | datum                 | $h$ | handgrip length                |
| 4 | handgrip support line | $z$ | cuff internal height           |
| 5 | handgrip width        | $a$ | Parallel.                      |

**Figure 2 — Details of an elbow crutch**

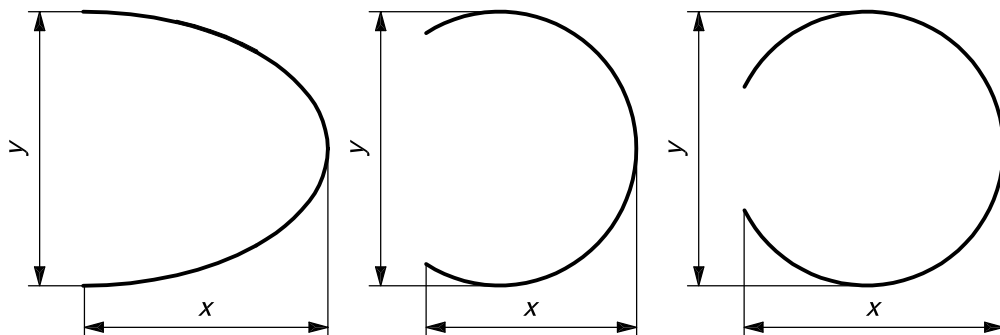

**Key**

- |     |                     |
|-----|---------------------|
| $x$ | cuff internal depth |
| $y$ | cuff internal width |

**Figure 3 — Cuff dimensions**

**3.21  
support angle**

$\alpha$   
angle formed by the leg section axis and the cuff support line

See Figure 1.

**3.22  
grip angle**

$\beta$   
angle formed by the cuff support line and the handgrip support line

See Figure 1.

## **4 Requirements**

### **4.1 Cuff**

The cuff internal depth against the forearm shall be larger than half of the internal width. This is verified by measurement, as indicated in 5.3.2 and Figure 3.

For the arm not to be trapped in accidentally, the cuff shall have an opening in the front side. When tested in accordance with 5.4, it shall be possible to increase this opening to 75 mm by applying a pulling force of maximum 120 N. The permanent deformation of the cuff opening shall not be more than 5 mm.

The cuff shall be securely fixed when tested in accordance with 5.5.

### **4.2 Handgrip**

The handgrip may be adjustable, but shall be securely fixed when tested in accordance with 5.5.

The handgrip width shall be not less than 25 mm and not more than 50 mm. This requirement does not apply to anatomic handgrips. This is verified by measurement, as indicated in 5.3.2 and Figure 2, item 5.

### **4.3 Leg section and tip**

The leg section shall end in a tip of a design that will prevent the leg section from piercing through the tip when tested in accordance with 5.6 and 5.7. This is verified by inspection.

The tip shall be replaceable, but shall be secure when fitted. This is verified by inspection.

The part of the tip that is in contact with the walking surface shall have a minimum diameter of 35 mm. This is verified by measurement, as indicated in 5.3.2.

### **4.4 Adjusting devices**

The means of height adjustment shall not become loose. This is verified by inspection after the crutch has been subjected to the tests described in 5.6 and 5.7.

Each of the height adjustments shall be clearly marked with its maximum allowable elongation. This is verified by measurement, as indicated in 5.3.2.

### **4.5 Materials**

If structural load carrying components moulded from recycled plastic materials are included, the components shall be of a strength equivalent to virgin materials throughout the life of the crutch.

## 4.6 Mechanical durability

When tested in accordance with the separation tests (see 5.5), none of the joints where parts of the crutch are joined together shall come apart.

When tested in accordance with the static loading test (see 5.6), the crutch shall stand the load and no part of the crutch shall crack or break.

When tested in accordance with the fatigue test (see 5.7), no part of the crutch shall crack or break.

When tested in accordance with the low temperature falling test (see 5.8), no part of the crutch shall crack or break.

## 5 Test methods

### 5.1 General

All tests, if not otherwise specified, shall be performed with the crutch adjustments at their maximum extension length setting.

### 5.2 Testing environment

All tests, if not otherwise stated, shall be performed at an ambient temperature of  $21^{\circ}\text{C} \pm 5^{\circ}\text{C}$ .

### 5.3 Sampling

#### 5.3.1 Test object

One crutch shall be tested. The sequence of tests shall be as follows:

- measurements;
- separation;
- static loading;
- fatigue;
- low temperature falling.

#### 5.3.2 Measurements

Measure the crutch and, at the same time, inspect the crutch for compliance with the manufacturer's specification. Make note of all the measurements taken and of any apparent defects, so that they shall not later be recorded as having been caused by the tests.

### 5.4 Forearm withdrawal test

#### 5.4.1 General

This test applies only to elbow crutches with a cuff opening smaller than 75 mm.

### 5.4.2 Procedure

A cylinder having an outside diameter of  $75 \text{ mm} \pm 2 \text{ mm}$  is placed inside the cuff. The cylinder is pulled through the cuff opening as shown in Figure 4. The force required to open the cuff sufficiently in order to pull the cylinder through is measured to an accuracy of  $\pm 2 \text{ N}$ , and noted.

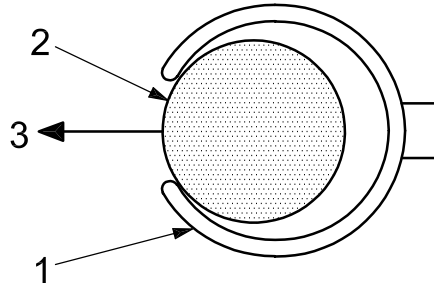

#### Key

- 1 cuff
- 2 cylinder
- 3 pulling force

Figure 4 — Loading geometry for forearm withdrawal test

## 5.5 Separation tests

### 5.5.1 General

These tests apply to crutches of more than one part that are joined together.

Each joint shall be tested for safe assembly. Joints relying on interference fit only shall be tested. Where a rivet locks a joint in addition to interference fit or similar, the testing personnel are at liberty to deem the joint as safe without testing. The procedure for applying the separation test to a handgrip to prove secure fit to the handle is described in detail. If applicable, the best procedure for applying the separation test to other joints will be at the discretion of the testing personnel. The procedure shall in each case take into account the construction of the particular crutch to be tested. The main principle of applying the separating force is that the joint shall experience an axial separation force only, and negligible radial or bending forces causing the joint to fasten more than is intended by the manufacturer. Clamps that cause the outer part of the joint to be squeezed on to the inner part are not permissible.

### 5.5.2 Loading geometry

#### 5.5.2.1 General

Apply a pulling force to the upper and lower part of the crutch, such that the crutch experiences no bending, causes stress where the upper and lower parts are joined together.

#### 5.5.2.2 Handgrips

Mount the elbow crutch in a fixture that leaves the handgrip free to be tested by an axial pulling force.

Apply the axial separation force to the handgrip, as shown in Figure 5, where a webbing strap has been secured to the handgrip by glue. If the webbing strap is kept in place by some means while the glue is bonding, this means has to be removed before the test is performed.

### 5.5.3 Separating force

#### 5.5.3.1 General

Apply a pulling force of  $500 \text{ N} \pm 2 \%$ , by increasing the force gradually over a minimum period of 2 s up to maximum force, and keep it at maximum force for at least 10 s.

#### 5.5.3.2 Handgrip

For a user mass of 100 kg, the separation force shall be as specified in 5.5.3.1. If the maximum mass of the user specified for the crutch deviates from a user mass of 100 kg, apply a force of 5 N/kg of the maximum mass of the user  $\pm 2 \%$ . The force shall be not less than  $175 \text{ N} \pm 2 \%$ . Apply the separation force as specified in 5.5.3.1.

### 5.5.4 Inspection

Any movement of one part of the joint relative to the other shall be noted.

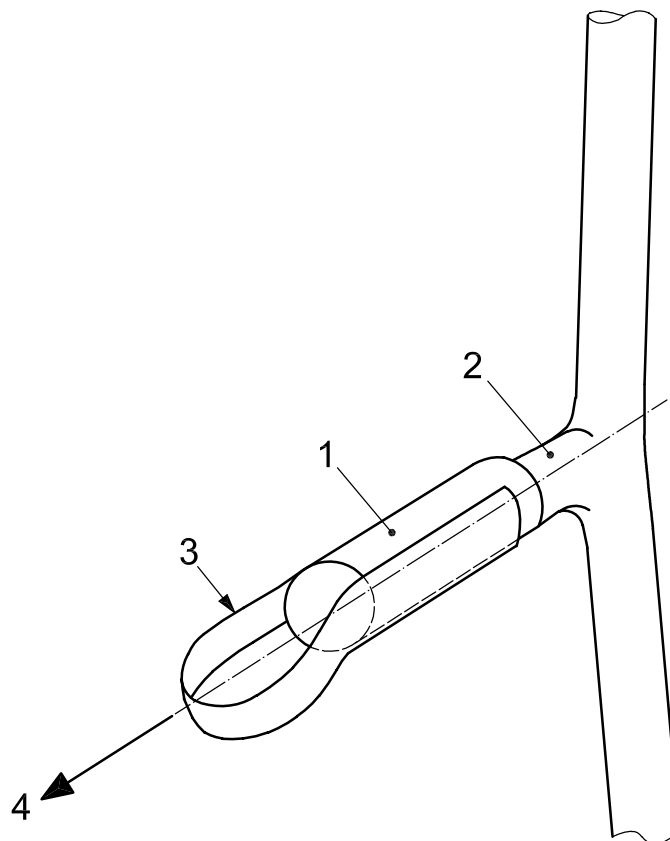

#### Key

- 1 handgrip
- 2 handle
- 3 webbing strap
- 4 axial loading force

Figure 5 — Loading geometry for handgrip test

## 5.6 Static loading test

### 5.6.1 Loading geometry

Apply the loading force via a dummy arm to the fully-extended crutch. The dummy arm consists of a dummy hand and a dummy forearm. The loading force shall be applied along the load line shown in Figure 6 to the dummy forearm, via a swivelling joint with its centre lower than the upper edge of the cuff. The dummy forearm shall rest against the cuff as closely as practical along the cuff support line (see Figure 1, item 1) and shall be hinged to the dummy hand at the wrist hinge point (see Figure 2, item 2). The dummy hand shall be clamped to the handgrip at the front handgrip reference point and supported against the rear handgrip reference point.

The method of fastening the dummy arm to the crutch shall not restrain, stiffen or strengthen the handgrip or crutch in any way that will jeopardise the result of the test by restricting the crutch in bending forwards, backwards or sideways relative to forward motion of the user when the crutch is in use.

The swivelling joint between the load and the dummy forearm shall be such that the dummy forearm is free to swing with the deformation of the elbow crutch under load. The freedom to swing shall be at least 15 ° in all directions.

The hinge between the dummy forearm and the dummy hand shall be such that the dummy forearm is free to move forwards and backwards and at least 4° sideways to either side when the dummy hand is fastened to the handgrip.

The position of the load line is described as the vertical load vector which passes through the centre of the tip and at a distance  $X$  from the datum, towards the rear of the crutch, as shown in Figure 6, item 2.  $X$  is calculated using the following empirical expression. The result is to be rounded to the nearest higher integer in millimetres.

$$X = \left\{ \frac{h}{3} + \frac{l \times a \times \sin \alpha}{(l + a \times \cos \alpha) 0,65} \right\} \sin \alpha \quad (1)$$

where

- $h$  is the handgrip length, in millimetres;
- $l$  is the leg section length, in millimetres;
- $a$  is the arm section length, in millimetres;
- $\alpha$  is the support angle, in degrees;
- 0,65 is the empirical factor.

The above does not preclude other methods of applying the force, but equivalent force/load characteristics in the crutch shall be maintained.

### 5.6.2 Loading force

A static loading force of 1 000 ± 2 % shall be applied for a user mass of 100 kg. If the maximum mass of the user specified for the crutch deviates from a user mass of 100 kg, apply a force of 10 N/kg of mass of the user ± 2 %. The force shall be not less than 350 N ± 2 %.

### 5.6.3 Loading time

Apply this force gradually over a minimum period of 2 s up to maximum force, and keep it at maximum force for 10 s.

### 5.6.4 Inspection

Inspect the crutch for cracks or breakages. Note visual cracks, breakages and whether the crutch cannot stand the load.

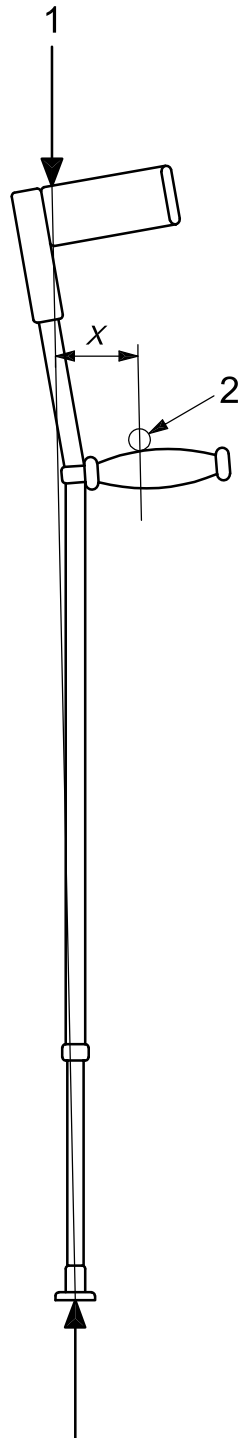
**Key**

- 1 load
- 2 datum
- $X$  distance from datum to load line

**Figure 6 — Loading geometry for static and dynamic loading**

## 5.7 Fatigue test

### 5.7.1 Loading geometry

Apply a loading force to the fully-extended crutch, as specified in 5.6.1.

### 5.7.2 Loading force

Apply a cyclic force of  $550 \text{ N} \pm 2 \%$  for a user mass of 100 kg. If the maximum mass of the user specified for the crutch deviates from a user mass of 100 kg, apply a force of  $5,5 \text{ N/kg}$  of the maximum mass of the user  $\pm 2 \%$ . The force shall be not less than  $192,5 \text{ N} \pm 2 \%$ . The waveform of the cyclic loading force shall be of a sinusoidal or smooth kind without exaggerating pulses.

### 5.7.3 Loading frequency

The frequency of the cyclic loading shall not exceed 5 Hz. If the crutch fails a test with a frequency higher than 1 Hz, perform a final test using a new sample tested at a frequency not exceeding 1 Hz.

### 5.7.4 Loading cycles

The number of cycles shall be 1 000 000.

Inspect all parts of the crutch for cracks or breakages. Note visual cracks, breakages and whether the crutch cannot stand the load.

## 5.8 Low temperature falling test

### 5.8.1 Testing environment

Place the crutch in an environment of  $-25 \text{ }^\circ\text{C} \pm 2 \text{ }^\circ\text{C}$  for 24 h.

### 5.8.2 Procedure

Within 30 s of being removed from the cold environment, hold the crutch vertically with the tip on the floor and allow it to fall under its own mass against a concrete floor. This test shall be done five times forwards, so that the crutch falls directly on to its handle, and five times to one side.

The test shall be completed within 5 min.

Inspect all parts for cracks or breakages.

## 5.9 Final inspection

When all tests have been completed, inspect all parts of the elbow crutch and its mechanisms and functions for satisfactory operation, as specified by the manufacturer. Note any discrepancies.

## 6 Information supplied by the manufacturer

### 6.1 General

Any information supplied should be appropriate for all users, including people with visual impairment.

The information applied to, and supplied with, elbow crutches shall conform to the relevant clauses of EN 1041 together with, but not limited to, the following requirements.



The information shall include advice on which other devices and/or types of devices can be used in combination with the elbow crutch in question, and any precautions or limitations to be heeded to ensure user safety. It shall also include information marked on the product and documentation (see 6.2 and 6.3).

NOTE Further guidance is given in ISO/IEC Guide 71.

## 6.2 Information marked on the product

Each crutch shall be clearly and indelibly marked with the following:

- a) maximum permissible user mass;
- b) manufacturer's name or trade name and address;
- c) manufacturer's model identification name and/or number;
- d) month and year of manufacture;
- e) maximum extension of the height adjustment, marked on the adjusting members.

## 6.3 Documentation

The following information shall be contained in the instructions for use and/or assembly, or clearly and indelibly marked on the product:

- a) maximum arm section length;
- b) minimum arm section length;
- c) maximum leg section length;
- d) minimum leg section length;
- e) support angle,  $\alpha$ ;
- f) cleaning instructions, including a description of the method and suitable cleaning agents and any precautions needed to avoid corrosion and/or ageing of the materials used in construction of the elbow crutch;
- g) instructions for assembly, adjustment of all kinds, folding and unfolding, if applicable;
- h) warnings and advice about precautions relating to safe distances between moving and stationary parts, if applicable (see EN 12182:1999, Clauses 12 and 13, for guidance).

NOTE 1 Most countries require that information be given in one or more of their official languages.

NOTE 2 ISO/IEC Guide 37 is of help when preparing this information.

## 7 Test report

The test report shall contain, but not be limited to, the following information:

- a) name and address of the manufacturer;
- b) name and address of the supplier of the product for test;
- c) name and address of the testing institution;
- d) classification code and name, in accordance with ISO 9999;
- e) maximum permissible user mass;
- f) handgrip length,  $h$ , arm section length,  $a$ , leg section length,  $l$ , and support angle,  $\alpha$ ;
- g) manufacturer's product type and model identification name and/or number;
- h) supplier's product type and model identification name and/or number;
- i) a photograph of the crutch;
- j) month and year when the test was performed;
- k) inspection report, as specified in 5.3.2;
- l) diameter of that part of the tip which is in contact with the walking surface;
- m) whether or not the product complies with the requirements of this part of ISO 11334;
- n) information on how to get access to the supplementary test report of A.11, if available.

## **Annex A** (informative)

### **Recommendations**

#### **A.1 General**

This annex gives supplementary information and guidance on details that also should be taken into account in the design, manufacture and testing of elbow crutches. However, the annex does not contain provisions to which it is necessary to conform in order to be able to claim compliance to this part of ISO 11334.

#### **A.2 Cuff**

The inside dimensions of the cuff should be so designed that the arm, even when covered with clothes, may with comparative ease be inserted into and withdrawn from it.

The cuff inside surface should be approximately parallel to the cuff support line. This is the case if the cuff is hinged.

The cuff internal height against the forearm should be at least 40 mm.

#### **A.3 Handle/handgrip**

The shape and/or the material of the handgrip should prevent the hand from sliding when gripped.

The handgrip should be easy to clean, non-absorbent and should not include known toxic components.

#### **A.4 Leg section and tip**

The tip should be pliable, hard wearing and have a high coefficient of friction against the walking surface. The tip tread against the walking surface should be such that any suction cup effect is avoided.

#### **A.5 Adjusting devices**

It should be possible to operate the means of adjustment without the use of tools.

#### **A.6 Materials**

Structural load carrying members moulded from plastic materials should be produced from virgin materials.

#### **A.7 Finish**

All parts of the crutch should be free from burr, sharp edges or projections that could cause damage to clothing or discomfort to the user.

The crutch should not rattle when in use.

The materials should not cause discolouring in normal use.

## A.8 Angles

The support angle,  $\alpha$ , should be as follows:  $15^\circ \leq \alpha \leq 30^\circ$

The grip angle,  $\beta$ , should be as follows:  $100^\circ \leq \beta \leq 108^\circ$

The difference of grip angle minus support angle should be as follows:  $\beta - \alpha \leq 90^\circ$

## A.9 Mechanical durability

When tested in accordance with tests 5.4, 5.5, 5.6 and 5.7, the crutch should not show any deformation resulting in a permanent set such as to impair the use of the crutch or adjusting mechanism(s).

## A.10 Marking and labelling

Each crutch should also be marked with the following:

- a) the supplier's name;
- b) the supplier's model identification name and/or number.

## A.11 Supplementary test report

In addition to the requirements given in Clause 7, the test report may contain part or all of the following information:

- a) results of the test described in 5.4;
- b) results of the test described in 5.5;
- c) results of the test described in 5.6;
- d) results of the test described in 5.7;
- e) results of the test described in 5.8;
- f) any findings of interest during the inspection described in 5.9;
- g) handgrip width;
- h) grip angle,  $\beta$ ;
- i) cuff internal width;
- j) cuff internal depth;
- k) cuff internal height;
- l) mass of the elbow crutch;
- m) any other relevant information.

## Bibliography

- [1] ISO 10993-1, *Biological evaluation of medical devices — Part 1: Evaluation and testing within a risk management system*
- [2] ISO/IEC Guide 37, *Instructions for use of products of consumer interest*
- [3] ISO/IEC Guide 71, *Guidelines for standards developers to address the needs of older persons and persons with disabilities*
- [4] EN 12182:1999, *Technical aids for disabled persons — General requirements and test methods*

