

Contents

Page

Introduction	vi
1 Scope	1
2 Normative references	1
3 Terms and definitions	2
4 Symbols	5
5 General requirements	7
6 Mechanical loads	7
6.1 General.....	7
6.2 Load during the pressure test.....	7
7 Chemical effects	8
8 Thermal conditions	8
9 Materials	8
9.1 Selection of materials.....	8
9.2 Inspection documentation.....	8
10 Design	9
10.1 Design options.....	9
10.1.1 General.....	9
10.1.2 Design by calculation.....	9
10.1.3 Design by calculation and pressure strengthening.....	9
10.1.4 Design of components by calculation supplemented with experimental methods.....	9
10.2 Common design requirements.....	9
10.2.1 General.....	9
10.2.2 Design specification.....	10
10.2.3 Design loads.....	11
10.2.4 Fatigue.....	15
10.2.5 Corrosion allowance.....	15
10.2.6 Inspection openings.....	16
10.2.7 Pressure relief.....	16
10.2.8 Valves.....	17
10.2.9 Insulation.....	17
10.2.10 Degree of filling.....	17
10.2.11 Electrical continuity.....	17
10.3 Design by calculation.....	17
10.3.1 General.....	17
10.3.2 Inner vessel.....	17
10.3.3 Outer jacket.....	20
10.3.4 Attachments.....	21
10.3.5 Piping and accessories.....	21
10.3.6 Calculation formula.....	21
10.3.7 Calculations for operating loads.....	45
11 Fabrication	46
11.1 General.....	46
11.2 Cutting.....	46
11.3 Cold forming.....	46
11.3.1 Austenitic stainless steel.....	46
11.3.2 Ferritic steel.....	47
11.3.3 Aluminium or aluminium alloy.....	48
11.4 Hot forming.....	48
11.4.1 General.....	48

11.4.2	Austenitic stainless steel.....	48
11.4.3	Ferritic steel.....	48
11.4.4	Aluminium or aluminium alloy.....	48
11.5	Manufacturing tolerances.....	48
11.5.1	General.....	48
11.5.2	Plate alignment.....	49
11.5.3	Thickness.....	50
11.5.4	Dished ends.....	50
11.5.5	Cylinders.....	50
11.6	Welding.....	53
11.6.1	General.....	53
11.6.2	Qualification.....	53
11.6.3	Temporary attachments.....	53
11.6.4	Welded joints.....	53
11.7	Non-welded joints.....	54
12	Inspection and testing.....	54
12.1	Quality plan.....	54
12.1.1	General.....	54
12.1.2	Inspection stages during manufacture of an inner vessel.....	54
12.1.3	Additional inspection stages during manufacture of a large transportable cryogenic vessel.....	55
12.2	Production control test plates.....	55
12.2.1	Requirements.....	55
12.2.2	Extent of testing.....	55
12.3	Non-destructive testing.....	56
12.3.1	General.....	56
12.3.2	Extent of examination for surface imperfections.....	56
12.3.3	Extent of examination for inner-vessel weld seams.....	57
12.3.4	Acceptance criteria for surface and volumetric imperfections as classified in ISO 6520-1.....	57
12.4	Rectification.....	58
12.5	Pressure testing.....	59
13	Marking and labelling.....	59
14	Final acceptance test.....	59
15	Periodic inspection.....	60
16	Documentation.....	60
Annex A	(informative) Examples of tank plates.....	61
Annex B	(informative) Elastic stress analysis.....	64
Annex C	(normative) Additional requirements for 9 % Ni steel.....	72
Annex D	(normative) Pressure strengthening of vessels from austenitic stainless steels.....	74
Annex E	(informative) Specific weld details.....	87
Annex F	(normative) Outer-jacket relief devices.....	91
Annex G	(informative) Base materials.....	92
Annex H	(informative) Components subject to external pressure (pressure on the convex surface) — Calculation.....	101
Annex I	(informative) Design of openings in cylinders, spheres and cones — Calculation.....	112
Annex J	(normative) Reference material & equivalent thickness.....	121
Annex K	(normative) Refrigerated liquefied gases.....	124
	Bibliography.....	125
	NATIONAL ANNEX L.....	126

Introduction

This document has been written so that it is suitable to be referenced in the UN Model Regulations^[1].

This document does not include the general vehicle requirements, e.g. running gear, brakes, lighting, etc., for which the relevant standards/regulations apply.

Indian Standard

L L L L
L L L

PART 1 DESIGN, FABRICATION, INSPECTION AND TESTING

(ISO 20421-1 : 2019, MOD)

1 Scope

This document specifies requirements for the design, fabrication, inspection and testing of large transportable vacuum-insulated cryogenic vessels of more than 450 l volume, which are permanently (fixed tanks) or not permanently (demountable tanks and portable tanks) attached to a means of transport, for one or more modes of transport.

This document applies to large transportable vacuum-insulated cryogenic vessels for fluids specified in [3.1](#) and does not apply to vessels designed for toxic fluids.

This document does not include the general vehicle requirements, e.g. running gear, brakes, lighting, etc.

NOTE 1 This document does not cover specific requirements for refillable liquid-hydrogen tanks that are primarily dedicated as fuel tanks in vehicles. For fuel tanks used in land vehicles, see ISO 13985.

NOTE 2 This document does not cover specific requirements for refillable liquid hydrogen and LNG tanks that are primarily dedicated as fuel tanks in vehicles. For fuel tanks used in vehicles, see ISO 13985.

2 Normative references

The following documents are referred to in the text in such a way that some or all of their content constitutes requirements of this document. For dated references, only the edition cited applies. For undated references, the latest edition of the referenced document (including any amendments) applies.

ISO 3834-2, *Quality requirements for fusion welding of metallic materials — Part 2: Comprehensive quality requirements*

ISO 4126-2, *Safety devices for protection against excessive pressure — Part 2: Bursting disc safety devices*

ISO 5817, *Welding — Fusion-welded joints in steel, nickel, titanium and their alloys (beam welding excluded) — Quality levels for imperfections*

ISO 9606-1, *Qualification testing of welders — Fusion welding — Part 1: Steels*

ISO 9606-2, *Qualification test of welders — Fusion welding — Part 2: Aluminium and aluminium alloys*

ISO 9712, *Non-destructive testing — Qualification and certification of NDT personnel*

ISO 10042, *Welding — Arc-welded joints in aluminium and its alloys — Quality levels for imperfections*

ISO 10474:2013, *Steel and steel products — Inspection documents*

ISO 10675-1, *Non-destructive testing of welds — Acceptance levels for radiographic testing — Part 1: Steel, nickel, titanium and their alloys*

ISO 14732, *Welding personnel — Qualification testing of welding operators and weld setters for mechanized and automatic welding of metallic materials*

ISO 15613, *Specification and qualification of welding procedures for metallic materials — Qualification based on pre-production welding test*

ISO 15614-1, *Specification and qualification of welding procedures for metallic materials — Welding procedure test — Part 1: Arc and gas welding of steels and arc welding of nickel and nickel alloys*

ISO 15614-2, *Specification and qualification of welding procedures for metallic materials — Welding procedure test — Part 2: Arc welding of aluminium and its alloys*

ISO 17635, *Non-destructive testing of welds — General rules for metallic materials*

ISO 17637, *Non-destructive testing of welds — Visual testing of fusion-welded joints*

ISO 20421-2, *Cryogenic vessels — Large transportable vacuum-insulated vessels — Part 2: Operational requirements*

ISO 21010, *Cryogenic vessels — Gas/material compatibility*

ISO 21011, *Cryogenic vessels — Valves for cryogenic service*

ISO 21028-1, *Cryogenic vessels — Toughness requirements for materials at cryogenic temperature — Part 1: Temperatures below -80 degrees C*

ISO 21028-2, *Cryogenic vessels — Toughness requirements for materials at cryogenic temperature — Part 2: Temperatures between -80 degrees C and -20 degrees C*

ISO 21013-3, *Cryogenic vessels — Pressure-relief accessories for cryogenic service — Part 3: Sizing and capacity determination*

ISO 23208, *Cryogenic vessels — Cleanliness for cryogenic service*

ASME VIII-2, *Rules for construction of pressure vessels, Division 2, Alternative Rules*

EN 13445-3, *Unfired pressure vessels — Part 3: Design*

3 Terms and definitions

For the purposes of this document, the following terms and definitions apply.

ISO and IEC maintain terminological databases for use in standardization at the following addresses:

— ISO Online browsing platform: available at <https://www.iso.org/obp>

— IEC Electropedia: available at <http://www.electropedia.org/>

3.1

cryogenic fluid

refrigerated liquefied gas

gas which is partially liquid because of its low temperature (see [Table K.1](#))

Note 1 to entry: This includes totally evaporated liquids and supercritical fluids.

Note 2 to entry: In the context of this document, the refrigerated but non-toxic gases and gas mixtures given in [Table K.1](#) are referred to as cryogenic fluids.

3.2

large transportable cryogenic vessel

tank

thermally insulated vessel of more than 450 l intended for the transport of one or more *cryogenic fluids* ([3.1](#)), consisting of an *inner vessel* ([3.4](#)), an *outer jacket* ([3.5](#)), all of the valves and *service equipment* ([3.9](#)) together with the structural parts

Note 1 to entry: The large transportable cryogenic vessel comprises a complete assembly that is ready for service.

3.3

insulation

vacuum interspace between the *inner vessel* (3.4) and the *outer jacket* (3.5)

Note 1 to entry: The space may or may not be filled with material to reduce the heat transfer between the inner vessel and the outer jacket.

3.4

inner vessel

pressure (3.16) vessel intended to contain the *cryogenic fluid* (3.1) to be transported

3.5

outer jacket

gas-tight enclosure which contains the *inner vessel* (3.4) and enables the vacuum to be established

3.6

normal operation

intended operation of the vessel at a *pressure* (3.16) not greater than the maximum allowable working pressure including the *handling loads* (3.7)

3.7

handling load

load exerted on the transportable cryogenic vessel in all normal conditions of transport including loading, unloading, moving and lifting

3.8

pipng system

all pipes, tubes and associated components which can come in contact with *cryogenic fluids* (3.1) including valves, fittings, pressure-relief devices and their supports

3.9

service equipment

measuring instruments and filling, discharge, venting, safety, heating, cooling and insulating devices including any equipment for storing cooling fluids

3.10

manufacturer

<large transportable cryogenic vessel> company that carries out the final assembly, including the final acceptance test, of the *large transportable cryogenic vessel* (3.2)

3.11

gross volume

<of the inner vessel> internal volume of the *inner vessel* (3.4), excluding nozzles, pipes, etc., determined at minimum design temperature and atmospheric *pressure* (3.16)

3.12

tare mass

mass of the empty *large transportable cryogenic vessel* (3.2)

3.13

net volume

volume of the *inner vessel* (3.4), below the inlet to the relief devices, excluding nozzles, pipes, etc., determined at minimum design temperature and atmospheric *pressure* (3.16)

3.14

net mass

maximum allowable mass of the *cryogenic fluid* (3.1) which may be filled

Note 1 to entry: The maximum allowable mass is equal to the mass of the cryogenic liquid occupying 98 % of the *net volume* (3.13) of the *inner vessel* (3.4) under conditions of incipient opening of the relief device with the vessel in a level attitude and the mass of the gas at the same conditions in the remaining volume of the inner vessel.

Note 2 to entry: Cryogenic liquid helium can occupy 100 % of the volume of the inner vessel at any *pressure* (3.16).

3.15

gross mass

sum of *tare mass* (3.12) plus *net mass* (3.14)

3.16

pressure

gauge pressure

pressure relative to atmospheric pressure

3.17

fixed tank

tank vehicle

large transportable vessel permanently attached to a vehicle or to units of running gear

3.18

demountable tank

large transportable vessel non-permanently attached to a vehicle

Note 1 to entry: When attached to the carrier vehicle, the demountable tank meets the requirements prescribed for a fixed tank. It is designed to be lifted only when empty.

3.19

portable tank

a thermally insulated tank having a capacity of more than 450 litres fitted with *service equipment* (3.9) and structural equipment necessary for the transport of refrigerated liquefied gases

Note 1 to entry: It can be lifted full and loaded and discharged without removal of structural element.

Note 2 to entry: The list of the refrigerated liquefied gases is available in [Annex K](#).

3.20

maximum allowable working pressure

ps

maximum gauge *pressure* (3.16) permissible at the top of the vessel in its normal operating position

3.21

relief plate

relief plug

plate or plug retained by atmospheric *pressure* (3.16) which allows relief of excess internal pressure, generally from the vacuum jacket

3.22

bursting disc device

non-reclosing pressure-relief device ruptured by differential *pressure* (3.16)

Note 1 to entry: It is the complete assembly of installed components including the bursting disc holder, where appropriate.

3.23

pressure-strengthened vessel

pressure (3.16) vessel which has been subjected to a calculated and controlled internal pressure (strengthening pressure) after completion, the wall thickness of which is calculated on the basis of the stress at the strengthening pressure and not on the basis of the conventional design stress value of the material used

Note 1 to entry: *Pressure* (3.16) vessels made from solution heat-treated material are subject to a controlled plastic deformation during the strengthening operation as its yield point is raised. Pressure vessels made from work-hardened material are subject to little or no plastic deformation.

3.24

residual elongation

original elongation of the steel minus the elongation created by the cold-forming deformation

3.25

leakproofness test

test using gas subjecting the shell and its *service equipment* (3.9), to an effective internal *pressure* (3.16) not less than 90 % of the MAWP but not greater than the design pressure

4 Symbols

Symbol	Definition	Unit
b	width of pad, ring or shell reinforcement	mm
c	allowance for corrosion	mm
d_i	diameter of opening	mm
d_a	outside diameter of tube or nozzle	mm
f	narrow side of rectangular or elliptical plate	mm
h	thickness of pad reinforcement	mm
l_c	cone length between effective stiffenings (see Figure 5)	mm
l	ligament (web) between two nozzles	mm
l_b, l'_b	buckling length	mm
l_s	length of nozzle reinforcement outstanding	mm
n	number of lobes	—
p	design pressure as defined in 10.3.2.2	—
p_c	calculation pressure as defined in 10.2.3.1 a)	bar (or MPa)
p_e	allowable external pressure limited by elastic buckling	bar (or MPa)
p_k	strengthening pressure	bar (or MPa)
p_L	liquid pressure	bar (or MPa)
p_p	allowable external pressure limited by plastic deformation	bar (or MPa)
p_s	maximum allowable gauge pressure	bar (or MPa)
p_T	test pressure (see 6.2)	bar (or MPa)
r	radius, e.g. inside knuckle radius of dished end and cones	mm
s	minimum thickness	mm
s_A	required wall thickness at opening edge	mm
s_e	actual wall thickness	mm
s_g	required wall thickness outside corner area	mm

s_n	length of nozzle reinforcement in stand	mm
s_S	wall thickness of nozzle	mm
s_1	required wall thickness within corner area	mm
t	in this context, centre-to-centre distance between two nozzles	mm
x	(decay-length zone) distance over which governing stress is assumed to act	mm
x_i	characteristic lengths ($i = 1,2,3$) to define corner area [Figure 7 a] and [Figure 7 b] and 10.3.6.5.4]	mm
η	factor indicative of the utilization of the permissible design stress in joints or factor allowing for weakenings	—
A	cross-sectional area of reinforcing element	mm ²
C, β	design factors	—
D	shell diameter	mm
D_a	outside diameter, e.g. of a cylindrical shell	mm
D_{a1}	outside diameter of connected cylinder (see Figure 7)	mm
D_{a2}	outside diameter at effective stiffening (see Figure 9)	mm
D_i	internal diameter, e.g. of a cylindrical shell	mm
D_k	design diameter (see Figure 7)	mm
D_s	shell diameter at nozzle (see Figure 8)	mm
E	Young's modulus	N/mm ²
I	moment of inertia of reinforcing element	mm ⁴
R_e	minimum guaranteed yield stress or 0,2 % proof stress at 20 °C (1 % proof stress for austenitic steel)	N/mm ²
R_m	minimum guaranteed tensile strength at 20 °C	N/mm ²
K	material property used for design (see 10.3.2.3)	N/mm ²
K_T	material property at temperature T in °C (e.g. K_{20} for material property at 20 °C (see 10.3.2.3.2))	N/mm ²
R	radius of curvature, e.g. inside crown radius of dished end	mm
S	safety factor at design pressure, in relation with R_e	—
S_k	safety factor against elastic buckling at design pressure	—
S_p	safety factor against plastic deformation	—
Z	auxiliary value	—

ν	Poisson's ratio	—
u	out of roundness (see 11.5.5.2)	—
φ	cone angle	°

5 General requirements

5.1 The large transportable cryogenic vessel shall safely withstand the mechanical and thermal loads and the chemical effects encountered during pressure test and normal operation. These requirements are deemed to be satisfied if [Clauses 6](#) to [12](#) are fulfilled. The vessel shall be marked in accordance with [Clause 13](#), tested in accordance with [Clause 14](#) and operated in accordance with ISO 20421-2.

5.2 Large transportable cryogenic vessels shall be equipped with valves, pressure-relief devices, etc., configured and installed in such a way that the vessel can be operated safely. The number of openings in the inner vessel for this equipment shall be kept to a minimum.

5.3 The large transportable cryogenic vessel shall be clean for the intended service in accordance with ISO 23208.

5.4 The manufacturer shall retain the documents referred to in [Clause 16](#), and all supporting documentation (including that from his subcontractors, if any), for a required period (e.g. product liability). In addition, the manufacturer shall retain all supporting and background documentation (including that from his subcontractors, if any) which establishes that the vessel conforms to this document.

6 Mechanical loads

6.1 General

The large transportable cryogenic vessel shall resist the mechanical loads mentioned in [10.2.3](#) without such deformation which can affect safety and which can lead to leakage. This requirement can be validated by:

- the calculation;
- the calculation and pressure-strengthening method, if allowed;
- the calculation and experimental method.

6.2 Load during the pressure test

The load exerted during the pressure test shall be calculated with [Formula \(1\)](#):

$$p_T \geq 1,3(p_S + 1) \text{ bar or } [p_T \geq 1,3(p_S + 0,1) \text{ MPa}] \quad (1)$$

where

- p_T is the test pressure (in bar);
- p_S is the maximum allowable pressure (in bar);
- +1 is the allowance for external vacuum (in bar).
- +0,1 is the allowance for external vacuum (in MPa).

7 Chemical effects

Due to operating temperatures and the materials of construction, the possibility of chemical action on the inner surfaces in contact with the cryogenic fluids can be neglected.

Due to the fact that the inner vessel is inside an evacuated outer jacket, neither external corrosion of the inner vessel, nor corrosion on the inner surfaces of the outer jacket will occur. Therefore, inspection openings are not required in the inner vessel or the outer jacket.

Corrosion allowance is also not required on surfaces in contact with the operating fluid or exposed to the vacuum interspace between the inner vessel and the outer jacket.

The material and the protection for the surfaces exposed to the atmosphere shall be suitable for intended use (e.g. resistant to industrial and marine atmospheres).

8 Thermal conditions

The following thermal conditions shall be taken into account:

For the inner vessel and its associated equipment the full range of temperature expected.

For the outer jacket and equipment thereof (other than equipment covered in [Clause 7](#)):

- a minimum working temperature of $-20\text{ }^{\circ}\text{C}$;
- a maximum working temperature of $50\text{ }^{\circ}\text{C}$.

NOTE 1 Some locations require lower minimum working temperature e.g. $-40\text{ }^{\circ}\text{C}$ and/or higher maximum working temperature, e.g. $+65\text{ }^{\circ}\text{C}$.

NOTE 2 This does not apply if the jacket is designed for a lower temperature to be marked on the nameplate.

9 Materials

9.1 Selection of materials

9.1.1 Materials which are, or can be, in contact with cryogenic fluids shall be in accordance with ISO 21010.

9.1.2 Materials used at low temperatures shall follow the requirements of the relevant parts of ISO 21028-1 and ISO 21028-2; for non-metallic materials, low-temperature suitability shall be validated by an experimental method, taking into account operating temperatures.

9.1.3 The base materials, listed in [Annex G](#), subject to meeting the extra requirements given in [Clauses 5](#) to [16](#), are suitable for and may be employed in the manufacture of the cryogenic vessels, in conformance with this document.

9.2 Inspection documentation

9.2.1 The material according to ISO 21028-1 and ISO 21028-2 shall be declared by an inspection certificate 3.1 in accordance with ISO 10474:2013, 5.1.

9.2.2 The material manufactured to a recognized International Standard shall meet the testing requirements of ISO 21028-1 and ISO 21028-2 and shall be declared by an inspection certificate 3.1 in accordance with ISO 10474:2013, 5.1.

9.2.3 The delivery of material which is not manufactured to a recognized International Standard shall be guaranteed by an inspection certificate 3.2 in accordance with ISO 10474:2013, 5.2 confirming that the material fulfils the requirements in [9.1](#). The material manufacturer shall follow a recognized International Standard for processing and establishing the guaranteed material properties.

9.2.4 The outer jacket and the equipment not subjected to low temperature shall be manufactured from material suitable for the intended service.

10 Design

10.1 Design options

10.1.1 General

The design shall be carried out in accordance with one of the options given in [10.1.2](#), [10.1.3](#) or [10.1.4](#).

Metallic materials used at cryogenic temperatures shall meet the requirements of the relevant clauses of ISO 21028-1 and ISO 21028-2.

In the case of 9 % Ni steel, the additional requirements in [Annex C](#) shall be satisfied.

10.1.2 Design by calculation

Calculation of all pressure- and load-bearing components shall be carried out. The pressure part thicknesses of the inner vessel and outer jacket shall not be less than required by [10.3](#). Additional calculations may be required to ensure the design is satisfactory for the operating conditions including an allowance for dynamic loads.

10.1.3 Design by calculation and pressure strengthening

The pressure-retaining capability of inner vessels manufactured from austenitic stainless steel, strengthened by pressure, shall be calculated in accordance with [Annex D](#).

10.1.4 Design of components by calculation supplemented with experimental methods

Where it is not possible to design non-inner vessel components by calculation alone, planned and controlled experimental means may be used provided that the results confirm the safety factors required in [10.3](#). An example is the application of strain gauges to assess stress levels.

10.2 Common design requirements

10.2.1 General

The requirements of [10.2.2](#) to [10.2.7](#) are applicable to all vessels irrespective of the design option used.

In the event of an increase in at least one of the following parameters, the initial design process shall be repeated to take account of these modifications:

- maximum allowable pressure;
- specific mass (density) of the densest gas for which the vessel is designed;
- maximum tare weight of the inner vessel;
- nominal length and/or diameter of the inner shell.

The initial design process shall be repeated also in the event of any change relative to:

- the type of material or grade (e.g. stainless steel to aluminium);
- the fundamental shape;
- the decrease in the minimum mechanical properties of the material being used;
- the modification of the design of an assembly method concerning any part under stress, particularly as far as the support systems between the inner vessel and the outer jacket or the inner vessel itself or the protective frame, if any, are concerned.

10.2.2 Design specification

To enable the design to be prepared, the following information which defines a vessel type shall be available:

- maximum allowable pressure;
- fluids intended to be contained;
- gross volume of the inner vessel;
- dimensions and allowable weight, taking into account characteristics of the vehicle;
- location of fastening points and loads allowable on these points;
- filling and emptying rate;
- range of ambient temperature, if different from [Clause 8](#);
- transportation mode (see [Tables 2](#) and [3](#)).

A design document in the form of drawings with text, if any, shall be prepared. It shall contain the information given above plus the following where applicable:

- definition of which components are designed by calculation, by pressure strengthening, by experiment;
- drawings with dimensions and thicknesses of load-bearing components;
- specification of all load-bearing materials including grade, class, temper, testing, etc., as relevant;
- applicable material test certificates;
- location and details of welds and other joints, welding and other joining procedures, filler, joining materials, etc., as relevant;
- calculations to verify conformance to this document;
- design test programme;
- non-destructive testing requirements;
- pressure test requirements;
- piping configuration, including type, size and location of all valves and relief devices;
- details of fastenings.

10.2.3 Design loads

10.2.3.1 General

10.2.3.1.1 The large transportable cryogenic vessel shall be able to withstand safely the mechanical and thermal loads encountered during a pressure test and normal operation. The static forces used shall be obtained as required in [10.2.3.1.2](#) and [10.2.3.1.3](#).

10.2.3.1.2 The inner vessel, its fastenings and supports shall be designed for the static forces obtained by multiplying the load factors applicable for the transportation modes given in [Table 1](#) with the maximum weight imposed on the inner vessel. The maximum weight imposed on the inner vessel shall include the weights of the inner vessel, its fastenings and supports, maximum permissible content, piping, insulation and any other item supported on the inner vessel. Each load case shall be considered separately, but all forces in a load case shall be considered acting simultaneously. The static forces obtained are equivalent to the dynamic loads experienced during normal operation of the transport vessel. The load factors for assessment of fatigue life are given in [Table 2](#).

10.2.3.1.3 The outer jacket, its fastenings and supports shall be designed for the static forces obtained by multiplying the load factors applicable for the transportation modes given in [Table 1](#) with the maximum weight imposed on the outer jacket. The maximum weight imposed on the outer jacket shall include the weights of the outer jacket, with all its enclosures including inner vessel filled to the maximum permissible capacity and the weights of all items fastened to or supported from/to the outer jacket such as piping, controls, cabinets, etc. Each load case shall be considered separately, but all forces in a load case shall be considered acting simultaneously. The static forces obtained are equivalent to the dynamic loads experienced during normal operation of the transport vessel. The load factors for assessment of fatigue life are given in [Table 2](#).

10.2.3.1.4 Fatigue life calculation shall be conducted according to EN 13445-3, ASME VIII-2 or equivalent standards/codes under consideration of the imperfections under [11.5](#), and shall be conducted for the highest number of expected cycles of all relevant loads during the life time with consideration of the following criteria.

The life time of the vessel may be specified and marked on the nameplate.

In fatigue evaluation of any item designed to withstand more than one load case, the maximum loadings in each direction from all applicable load cases shall be considered to act simultaneously in determining the magnitude of alternating stresses. The usage factor shall not exceed 0,5 for the inner tank, and 1,00 nor for the outer tank.

NOTE Fatigue analysis as stated above can be satisfied for existing designs through documented evidence of previous long-term satisfactory service under the same operating conditions.

Table 1 — Design load factors in specified transportation modes

Transportation modes	Load case	Load factors				
		Forward	Backward	Up	Down	Lateral
Road and water	1	2,0			1,0	
	2		2,0		1,0	
	3			1,0		
	4				2,0	
	5 ^a				1,0	1,0

NOTE For mixed transportation modes, the higher appropriate design factor applies.

^a Load case 5A should be considered instead of load case 5 if the direction of the travel is not known.

^b The cushioning devices should be tested to demonstrate their ability to limit forces transmitted from the coupler to the tank is less than twice the weight of the tank filled to its rated capacity at a 16 kilometre per hour impact.

Table 1 (continued)

Transportation modes	Load case	Load factors				
		Forward	Backward	Up	Down	Lateral
	5A ^a				1,0	2,0
Rail with cushioning devices ^b	1	2,0			1,0	
	2		2,0		1,0	
	3			2,0		
	4				2,0	
	5				1,0	2,0
Rail without cushioning devices ^b	1	4,0			1,0	
	2		4,0		1,0	
	3			2,0		
	4				2,0	
	5 ^a				1,0	2,0
	5A ^a				1,0	4,0

NOTE For mixed transportation modes, the higher appropriate design factor applies.

^a Load case 5A should be considered instead of load case 5 if the direction of the travel is not known.

^b The cushioning devices should be tested to demonstrate their ability to limit forces transmitted from the coupler to the tank is less than twice the weight of the tank filled to its rated capacity at a 16 kilometre per hour impact.

Table 2 — Load factors for normal operation for fatigue analysis in specified transportation modes

Transportation modes	Load case	Load factors					
		Forward	Backward	Up	Down		Lateral
		cyclic	cyclic	cyclic	cyclic	steady	cyclic
Road and water	1	0,7				1,0	
	2		0,7			1,0	
	3			1,0			
	4				1,0	1,0	
	5					1,0	0,7
Rail with cushioning devices ^b	1	2,0				1,0	
	2		2,0			1,0	
	3			1,0			
	4				1,0	1,0	
	5 ^a					1,0	1,0
	5A ^a					1,0	2,0
Rail without cushioning devices ^b	1	4,0				1,0	
	2		4,0			1,0	
	3			1,0			
	4				1,0	1,0	
	5 ^a					1,0	1,0
	5A ^a					1,0	4,0

^a Load case 5A should be considered instead of load case 5 if the direction of the travel is not known.

^b The cushioning devices should be tested to demonstrate their ability to limit forces transmitted from the coupler to the tank is less than twice the weight of the tank filled to its rated capacity at a 16 kilometre per hour impact.

10.2.3.2 Inner vessel

10.2.3.2.1 The following loads shall be considered to act in combination where relevant:

a) calculation pressure, p , with [Formula \(2\)](#):

$$p = p_S + p_L + 1 \text{ bar or } (p = p_S + p_L + 0,1 \text{ MPa}) p_c \quad (2)$$

where p_L is the pressure, in bar, exerted by the mass of the liquid contents when the vessel is filled to capacity and subject to each load defined in [10.2.3.1](#), with either:

- 1) boiling liquid at atmospheric pressure; or
 - 2) cryogenic fluid at its equilibrium triple point or melting-point temperature at atmospheric pressure;
- b) loads imposed on the inner vessel due to the mass of the inner vessel and its contents when subject to each of the loads defined in [10.2.3.1](#);
- c) loads imposed by the piping due to the differential thermal movement of the inner vessel, the piping and the outer jacket, in which the following cases shall be considered:
- cool down (inner vessel warm/piping cold);
 - filling and withdrawal (inner vessel cold/piping cold); and
 - transport and storage (inner vessel cold/piping warm);
- d) reactions at the support points of the inner vessel during operation when the vessel contains cryogenic liquid product. The reactions shall be determined as described in [10.2.3.1.1](#);
- e) reactions at the support points of the inner vessel during operation when the vessel contains only gaseous product at 20 °C. The reactions shall be determined as described in [10.2.3.1.1](#).

10.2.3.2.2 The design shall be evaluated for the following conditions:

Pressure test: the value used for validation purposes shall be considered for each element of the vessel, e.g. shell courses, head, etc., [see [Formula \(3\)](#)]:

$$p_T \geq 1,3(p_S + 1) \text{ bar or } [p_T \geq 1,3(p_S + 0,1) \text{ MPa}] \quad (3)$$

where p_S is the maximum allowable pressure.

The 1 bar (0,1 MPa) is added to allow for the external vacuum. The primary membrane stress at test pressure shall not exceed the prescribed value but in no case the yield stress of the material.

The minimum test pressure of the inner vessel shall be 3 bar (0,3 MPa). This requirement does not apply to heating or cooling systems including cooling fluid reservoirs, and related service equipment.

10.2.3.3 Outer jacket

The following loads shall be considered to act in combination where relevant:

- a) an external pressure of 1 bar (0,1MPa);
- b) an internal pressure equal to the set pressure of the outer-jacket pressure relief device;
- c) load imposed by the inner-vessel and its contents at the support points in the outer jacket when subject to the forces specified in [10.2.3.1.1](#) and [10.2.3.1.2](#) and [Tables 2](#) and [3](#);

- d) load imposed by piping as defined in [10.2.3.2.1 c\)](#);
- e) load imposed at the inner-vessel support points in the outer jacket when the inner vessel cools from ambient to operating temperature and during operation;
- f) reactions at the outer-jacket fastening points when subject to the forces specified in [10.2.3.1.2](#) and [Tables 2](#) and [3](#).

10.2.3.4 Self-supporting vessels

In the case of vehicles in which the inner vessel and possibly the outer jacket constitute stressed self-supporting members of the vehicle, these shall be designed to withstand the stresses thus imposed in addition to stresses from other sources [see [10.2.3.2.1 c\)](#) and [10.2.3.3 f\)](#)].

10.2.3.5 Inner-vessel supports

The inner-vessel supports shall be designed for the loads specified in [10.2.3.1](#) and [10.2.3.2](#) to a maximum allowable stress value equal to $\frac{2}{3}K_{20}$.

Hardening effects where guaranteed can be considered in the allowable stress

10.2.3.6 Surge plates

The inner-vessel shall be divided by surge plates to provide stability and limit dynamic loads to the requirements of [10.2.3](#), unless it is to be filled equal to or more than 80 % of its capacity or nominally empty. The cross-sectional area of the surge plate shall be at least 70 % of the cross-section of the vessel.

The volume between surge plates shall not exceed $\frac{10500}{s_g}$ litres where s_g is the specific gravity of the cryogenic fluid at 1 bar (0,1 MPa) saturation.

Surge plates and their attachments to the shell shall be designed to resist the stresses caused by a pressure evenly distributed across the area of the surge plate. The pressure is calculated by considering the mass of liquid between the plates decelerating at $2g$ ([10.2.3](#)).

10.2.3.7 Outer-jacket supports

The outer-jacket supports shall be suitable for the load defined in [10.2.3.3](#).

10.2.3.8 Fastening points

Fastening points shall be suitable for fastening the large transportable cryogenic vessel to the vehicle when filled to capacity and subject to each of the loads defined in [10.2.3](#).

10.2.3.9 Protection of upper fittings

The fittings and accessories mounted on the upper part of the vessel shall be protected in such a way that damage caused by overturning cannot impair operational integrity. This protection may take the form of cylindrical profile of the vessel, of strengthening rings, protective canopies or transverse or longitudinal members so shaped that effective protection is given (e.g. structures of frame such as in ISO 1496-3). External stiffening rings shall not be used on vacuum jacket of tanks for flammable fluids.

10.2.3.10 Stability

The overall width of the ground-level bearing surface (distance between the outer points of contact with the ground of the right-hand tyre and the left-hand tyre of the same axle) shall be at least equal to 90 % of the height of the centre of gravity of the fully laden tank vehicle. In an articulated vehicle, the

mass on the axles of the load-carrying unit of the laden semitrailer shall not exceed 60 % of the nominal total laden mass of the complete articulated vehicle.

10.2.3.11 Piping and valves

Piping including valves, fittings and supports shall withstand the following loads. With the exception of a), the loads shall be considered to act in combination where relevant.

- a) Pneumatic pressure test: not less than the allowable working pressure p_s plus 1 bar (0,1 MPa) for piping inside the vacuum jacket.
- b) Pressure during operation: not less than the set pressure of the system pressure-relief device.
- c) Thermal loads defined in [10.2.3.2.1](#) d).
- d) Dynamic loads.
- e) Set pressure of thermal-relief devices where applicable.
- f) Loads generated during pressure-relief discharge.

Piping and accessories shall be designed such that their lowest natural frequency is equal to or higher than 30 cycles per second.

This equipment shall be protected or positioned so as to be protected against the risk of being wrenched off or damaged during transport.

In the particular case of liquid with a boiling temperature colder than that of liquid nitrogen, the possibility of air condensing on uninsulated parts shall be considered.

The leakproofness of this equipment shall be ensured in the event of overturning of the vehicle. The gaskets shall be made of a material compatible with the fluid carried, in accordance with ISO 21010.

Each bottom-filling or bottom-discharge opening shall be provided with at least two independent shut-off devices in series, the first being a stop valve situated as close as possible to the outer jacket and provided with protection against mechanical damage at least equal to that afforded by the outer jacket.

For flammable fluids only, in order to prevent leaks of flammable fluids, the first stop valve shall be a quick-closing safety device which closes automatically in the event of an unintended movement of the vehicle or of fire during the filling/emptying operation. It shall also be possible to operate the closing device by remote control. All vent pipes, including pressure-relief devices and purge valves, shall be connected to a vent pipe allowing safe discharge. The control cabinet shall be vented so that flammable gas cannot accumulate inside.

10.2.4 Fatigue

The design shall take into account the effect of cyclic stress on the inner vessel, outer jacket and their attachments during normal conditions of operation, as listed in [Table 2](#), including pressure cycles.

When considering the case of fatigue, the common requirement of designing with loads according to [10.2.3](#) is such as to accommodate the effects of fatigue. It can be necessary to pay particular attention to specific details in the supports and piping systems to avoid stress raisers.

10.2.5 Corrosion allowance

Corrosion allowance is not required on surfaces in contact with the operating fluid. Corrosion allowance is not required on other surfaces if they are adequately protected against corrosion.

NOTE 1 Due to the combination of materials of construction and operating fluids, internal corrosion cannot occur.

NOTE 2 The inner vessel is inside the evacuated outer jacket and, hence, external corrosion of the inner vessel cannot occur.

10.2.6 Inspection openings

Inspection openings are not required in the inner vessel or the outer jacket, provided that the requirements of ISO 20421-2 are followed.

NOTE The elimination of inspection openings also assists in maintaining the integrity of the vacuum in the interspace.

10.2.7 Pressure relief

10.2.7.1 General

Relief systems shall be designed to meet the requirements given in [10.2.7.2](#) to [10.2.7.4](#).

10.2.7.2 Inner vessel

10.2.7.2.1 Every shell shall be provided with not less than two independent spring-loaded pressure relief devices set at pressures not exceeding the maximum allowable pressure of the tank. The pressure relief devices shall open automatically at pressures not less than the set pressure of the device and be fully open at a pressure equal to 110 % of the set pressure. These devices shall, after discharge, close at a pressure not lower than 10 % below the pressure at which discharge starts and shall remain closed at all lower pressures. The pressure relief devices shall be of the type that will resist dynamic forces including surge.

10.2.7.2.2 In the case of the loss of vacuum, an additional reclosing pressure-relief device, set at no more than 110 % of the maximum allowable pressure, may be used, and the combined capacity of all pressure-relief devices installed shall be sufficient, so that the pressure (including accumulation) inside the vessel does not exceed 120 % of the maximum allowable pressure, in accordance with this document. For non-flammable refrigerated liquefied gases (except oxygen) and hydrogen, this capacity may be achieved by the use of bursting discs in parallel with the required safety relief devices. Bursting discs shall rupture at nominal pressure equal to the test pressure.

10.2.7.2.3 Under the circumstances described in [10.2.7.2.1](#) and [10.2.7.2.2](#), together with complete fire engulfment, the combined capacity of all pressure-relief devices shall be sufficient to limit the pressure in the vessel to the test pressure, providing the piping capacity and effects of back pressures are properly accounted for.

10.2.7.2.4 Relief devices for inner vessels shall be in accordance with ISO 21013-1 and ISO 21013-2.

10.2.7.2.5 The required capacity of the relief devices shall be calculated in accordance with ISO 21013-3.

The pressure-relief system shall be sized so that the pressure drop during discharge does not cause the valve to reseat instantly.

10.2.7.3 Outer jacket

Relief devices for the outer jacket shall be in accordance with [Annex F](#).

A pressure-relief device shall be fitted to the outer jacket. The device shall be set to open at a pressure which prevents collapse of the inner vessel and is not more than 0,5 bar (0,05 MPa). The total discharge area of the pressure relief device(s) should not be less than 0,34 mm²/l capacity of the inner vessel.

10.2.7.4 Piping

Any section of pipework containing cryogenic fluid which can be isolated shall be protected by a relief valve or other suitable relief device.

10.2.8 Valves

Valves shall conform to ISO 21011.

10.2.9 Insulation

For oxygen or gases having a boiling point below $-182\text{ }^{\circ}\text{C}$ at atmospheric pressure, the insulation installed on the tank shall be in accordance with ISO 21010.

Heat shields cooled by non-flammable, non-toxic fluid being transported of a different fluid carried separately or both and is vented to atmosphere may be used in UN portable tanks for refrigerated liquefied gases to reduce the heat flow into the fluid being carried. The vented fluid shall be in gaseous state and the venting shall be done in an environmentally friendly manner with temperature of the venting gas not less than $40\text{ }^{\circ}\text{C}$ below the ambient temperature and pressure of the venting gas not higher than 0,75 bar.

10.2.10 Degree of filling

The degree of filling of large transportable vacuum-insulated vessels shall remain below the level at which, if the contents were raised to the temperature at which the vapour pressure equalled to opening pressure of the lowest set pressure relief valve on stream, the volume of the liquid would reach 98 % of the vessel's net volume. Degree of filling for helium may be 100 % of the net volume. Pre-trip inspection shall ensure that the above limits are not exceeded.

In some countries, same degree of filling, without taking into account liquid expansion, is allowed when the intended duration of carriage is considerably shorter than the holding time.

10.2.11 Electrical continuity

All metallic components of large transportable vacuum-insulated vessels intended for the carriage of flammable gases shall be electrically continuous. The electrical resistance, as measured by an ohmmeter, between the inner vessel and/or related metallic components to the vehicle chassis shall not exceed 10 ohms.

10.3 Design by calculation

10.3.1 General

The dimensions of the inner vessel and outer jacket shall not be less than that determined in accordance with this subclause.

10.3.2 Inner vessel

10.3.2.1 General

The minimum thickness of the inner vessel shall be the larger of the thickness value from [Table 3](#) or [10.3.6](#).

Table 3 — Inner-vessel minimum wall thickness

Dimensions in millimetres

Inner vessel diameter <i>D</i>	Minimum wall thickness for reference material ^a <i>s_r</i>
$D \leq 1\,800$	3
$D > 1\,800$	4

^a Reference material is material having a product $R_m \times A_5$ of approximately 10 000, which yields $(R_m \times A_5)^{1/3} = 21,4$.
For other materials, the required minimum thickness of the metal used shall be calculated from [Annex J](#).

The R_m and A_5 values at a temperature not lower than the saturation temperature of the fluid at pressure p_s shall be determined from the appropriate material standard or shall be guaranteed by the material manufacturer.

10.3.2.2 Design pressure, p

The internal design pressure, p , shall be the greater of p_T as defined in [10.2.3.2.1 a\)](#), or p_C as defined in [10.2.3.2.2](#), corrected for operating conditions (i.e. multiplied by $\frac{K_{20}}{K_T}$) to take into account the cold

properties of the material used. It follows that shall K_{20} be used in the subsequent formulae where p is shown as the design pressure. The inner vessel shall be designed for an external pressure equal to the set pressure of the outer jacket pressure relief device.

10.3.2.3 Material properties, K

10.3.2.3.1 General

The material property, K , to be used in the calculations shall be as follows:

- for austenitic stainless steels, $R_{e\ 1,0}$ proof strength;
- for carbon steels, aluminium and aluminium alloys, R_e = yield strength and, if not available, $R_{e\ 0,2}$ proof strength.

For calculation purposes the material property, K , of the inner vessel shall be limited to $0,75 R_e$ or $0,5 R_m$ (the minimum guaranteed tensile strength), whichever is the most stringent.

10.3.2.3.2 K_{20}

R_e and R_m shall be the minimum guaranteed values at 20 °C taken from the material standard.

In the case of austenitic stainless steels, the specified minimum values may be exceeded by up to 15 % for carrying all loads listed in [10.2.3.2](#), except for the design pressure, p , specified under [10.2.3.2.1 a\)](#).

The 15 % higher values of K_{20} may be used provided this higher value is attested in the inspection certificate and the following conditions are met:

- the material manufacturer shall guarantee compliance with this higher value, in writing, when accepting the order;
- the increased properties shall be verified by testing each cast (production lot);
- the welding procedure shall be suitably qualified.

Values of R_e and R_m used for design calculations shall be the minimum specified values of R_e and R_m in the material inspection certificate except that the value of R_e used shall not exceed $0,85 R_m$.

10.3.2.3.3 K_t

The permissible values of R_e and R_m shall be determined for the material at the operating temperature corresponding to a temperature not lower than the saturation temperature of the fluid at pressure, p_s . The values of R_e , R_m and E shall be determined from the appropriate material standard or shall be guaranteed by the material manufacturer.

10.3.2.3.4 Brittleness

The material shall not be subject to brittle fracture at its minimum operating temperature (see ISO 21028-1 and ISO 21028-2).

10.3.2.3.5 Elongation

For steel, the elongation at fracture in % shall be not less than [Formula \(4\)](#) at 20 °C:

$$\frac{10000}{S_D} \text{ at } 20^\circ\text{C} \quad (4)$$

where S_D is the determined tensile strength in N/mm².

In any case, it shall be not less than 16 % for fine grained steels and not less than 20 % for other steels. For aluminium and aluminium alloys the elongation at fracture shall not be less than 12 %.

Elongation and determined tensile strengths are the actual values indicated in the material certificates.

10.3.2.4 Safety factors S , S_p and S_k

Safety factors are the ratio of material property K , K_{20} , or K_t over the maximum allowable stress.

a) Internal pressure (pressure on the concave surface): $S = 1,33$.

b) External pressure (pressure on the convex surface):

— cylindrical shells: $S_p = 1,4$;

$S_k = 2,6$;

— spherical region: $S_p = 2,1$;

$S_k = 2,6 + 0,0018 R/s_e$;

— knuckle region: $S_p = 1,6$.

10.3.2.5 Weld joint factor, η

$\eta = 1$ for all butt double-welded joints and single-welded butt joints with removable backing strips with complete penetration and full fusion and circumferential seams with permanent backing strip and circumferential joggle joints.

10.3.2.6 Corrosion allowances, c

$c = 0$

No corrosion allowance is required.

10.3.3 Outer jacket

10.3.3.1 General

The following shall be used to determine the pressure part thickness in conjunction with [Formulae \(6\)](#) and [\(7\)](#).

The reference material equivalent thickness of the outer jacket shall be determined using [Annex J](#).

The aggregate reference material equivalent thickness of the outer-jacket wall and inner-vessel wall shall be not less than 5 mm if the diameter of the inner vessel is not more than 1 800 mm, and not less than 6 mm if this diameter is more than 1 800 mm. The minimum thickness in reference steel of outer jacket of tanks for flammable fluids shall be 6 mm.

10.3.3.2 Calculation pressure, p

The internal calculation pressure, p , shall be not less than the set pressure of the outer, jacket pressure, relief device.

The external calculation pressure shall be 1 bar (0,1 MPa).

10.3.3.3 K_{20}

See [10.3.2.3.2](#).

10.3.3.4 Safety factors S , S_p and S_k in relation to K , K_{20} or K_T

- a) Internal pressure (pressure on the concave surface): $S = 1,73$ may be reduced to 1,5 for road transportation mode, if allowed.
- b) External pressure (pressure on the convex surface):
 - cylindrical shells: $S_p = 1,1$;
 $S_k = 2,0$;
 - spherical region: $S_p = 1,6$;
 S_k (see applicable method in [Annex H](#));
 - knuckle region: $S_k = 1,2$.

10.3.3.5 Plastic deformation

Resistance to plastic deformation is determined by using [10.3.6.1.3](#) with the appropriate safety factor, S_p , defined in [10.3.2.4](#) and [10.3.3.4](#).

10.3.3.6 Weld joint factor, η

For internal pressure (pressure on the concave surface), $\eta = 0,85$.

For external pressure (pressure on the convex surface), $\eta = 1,0$.

10.3.3.7 Corrosion allowances, c

For austenitic stainless steel, $c = 0$.

For aluminium alloys, $c = 0$.

For carbon steel, $c = 1,0$ mm.

NOTE c can be reduced to zero if the external surface is adequately protected against corrosion.

10.3.4 Attachments

For those items attached to the inner vessel wall, other than the inner-vessel supports (see [10.2.3.4](#)), the allowable stress shall not exceed the $0,75 K_{20}$ or $0,75 K_T$ as applicable. Other attachments to the jacket shall be designed for the loads defined in [10.2.3.1](#) using established design methods and allowable stress not exceeding $0,75 K_{20}$. See also [Annex B](#) for an acceptable method.

When the inner vessel is being designed, the temperature and corresponding mechanical properties of the structural attachment attached to the inner vessel may be those of the component in question when the inner vessel is filled to capacity with cryogenic fluid at a temperature not lower than the saturation temperature at pressure p_s . However, it shall be checked whether the stresses are acceptable in warm conditions (vessel empty).

10.3.5 Piping and accessories

Piping shall be designed for the loads defined in [10.2.3.11](#) using established piping design methods and safety factors. However, the overall safety factor used on the material property, K , shall not be less than the values given in [10.3.2.3](#).

10.3.6 Calculation formula

10.3.6.1 Cylindrical shells and spheres subject to internal pressure (pressure on the concave surface)

10.3.6.1.1 Field of application

The field of application for cylindrical shells and spheres is [Formula \(5\)](#):

$$D_a/D_i \leq 1,2 \quad (5)$$

10.3.6.1.2 Openings

For reinforcement of openings, see [10.3.6.7](#).

10.3.6.1.3 Calculation

The required minimum wall thickness, s , for cylindrical shells is [Formula \(6\)](#):

$$s = \frac{D_a p}{20 \frac{K_{20}}{S} \eta + p} + c \quad (6)$$

The required minimum wall thickness, s , for spherical shells is [Formula \(7\)](#):

$$s = \frac{D_a p}{40 \frac{K_{20}}{S} \eta + p} + c \quad (7)$$

In case of p in MPa, conversion shall be considered.

10.3.6.2 Cylindrical shells subject to external pressure (pressure on the convex surface)

10.3.6.2.1 Field of application

The field of application for cylindrical shells is [Formula \(8\)](#):

$$D_a/D_i \leq 1,2 \quad (8)$$

10.3.6.2.2 Openings

Openings shall be calculated in accordance with [10.3.6.7](#) using the external pressure as an internal pressure.

10.3.6.2.3 Calculation

[Annex H](#) gives two alternative calculation methods. Both methods give comparable results and shall be equally accepted.

10.3.6.3 Spheres subject to external pressure (pressure on the convex surface)

See [Annex H](#).

10.3.6.4 Dished ends

10.3.6.4.1 Field of application

The following dish ends may be used:

- a) hemispherical ends where $D_a/D_i \leq 1,2$;
- b) torispherical ends where $0,5 D_a \leq R \leq D_a$ and $0,5 D_a \geq r \geq 0,06 D_a$;
- c) 2:1 elliptical ends where $R = 0,9 D_a$ and $r = 0,170 D_a$.

NOTE In the case of elliptical ends, $0,001 \leq (s - c)/D_a \leq 0,1$.

Dished ends of vacuum jackets are not required to meet the above restrictions on R and r , when r is greater than or equal to $3 s$.

10.3.6.4.2 Straight flange

The straight flange length, h_1 [[Figure 1](#) a) and b)], shall not be less than:

- for 10 % torispherical ends: $3,0 s$;
- for 2:1 torispherical ends: $3,0 s$;
- for 2:1 elliptical ends: $3,0 s$.

The straight flange may be shorter provided that in the case of inner vessels, the circumferential joint between the dished end and the cylinder is non-destructively tested as required for a weld joint factor of 1,0.

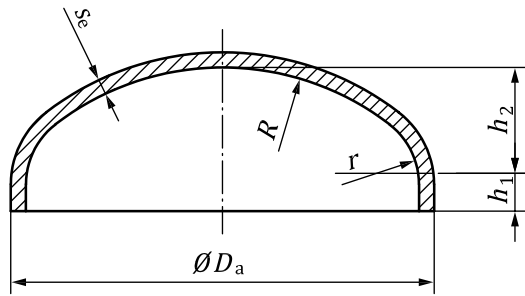

a) Unpierced dished end

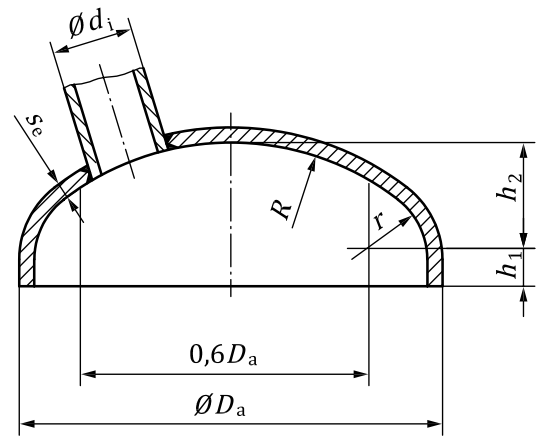

b) Dished end with nozzle

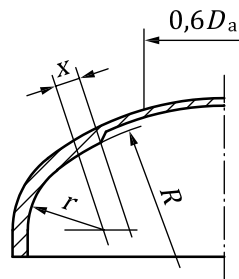

c) End with knuckle and crown of unequal wall thickness

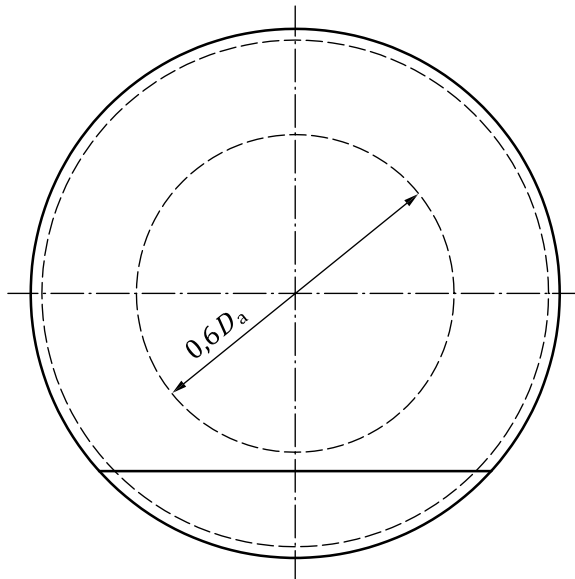

$\eta = 0,85$ or $1,0$

d) Weld outside $0,6 D_a$

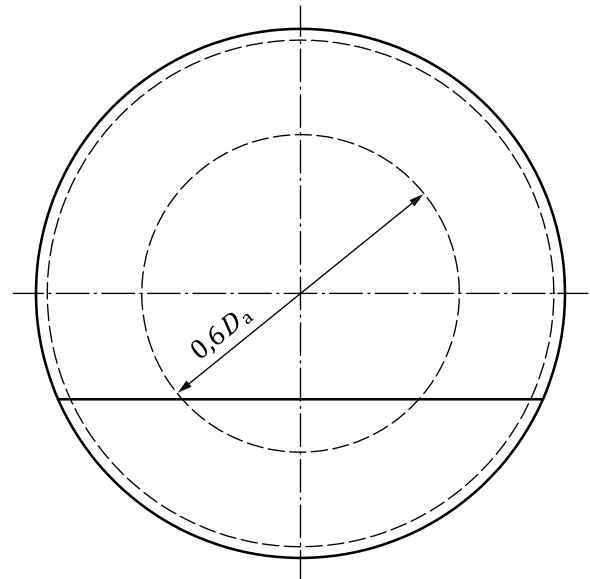

$\eta = 1,0$

e) Weld inside $0,6 D_a$

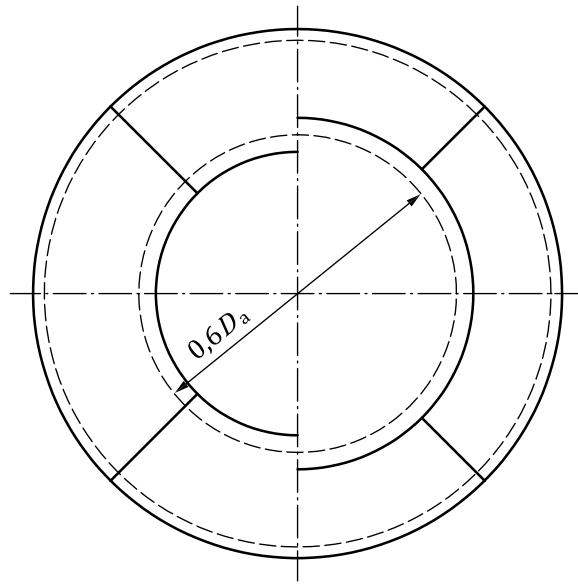

$$\eta = 1,0 \quad \eta = 0,85 \text{ or } 1,0$$

f) End welded together from round plate and segments

Figure 1 — Examples of dished ends

10.3.6.4.3 Internal-pressure calculation (pressure on concave surface)

10.3.6.4.3.1 Crown and hemisphere thickness

The wall thickness of the crown region of dished ends and of hemispherical ends shall be determined using [10.3.6.1.3](#) for spherical shells with $D_a = 2(R + s)$.

The opening within the crown area of $0,6 D_a$ of torispherical ends and in hemispherical ends shall be reinforced in accordance with [10.3.6.7](#). When pad-type reinforcement is used, the edge of the pad shall not extend beyond the area of $0,8 D_a$.

10.3.6.4.3.2 Torispherical end knuckle thickness and hemispherical end to shell junction thickness

The required thickness of the knuckle region or hemispherical end junction shall be [Formula \(9\)](#):

$$s = \frac{pRM}{20 \frac{K_{20}\eta}{S} - 0,2p} \quad (9)$$

where

$$M = 0,25 \left(3 + \sqrt{\frac{R}{r}} \right);$$

R is the inside crown radius;

r is the inside knuckle radius.

In case of p in MPa, conversion shall be considered.

Dished ends designed for normal operation under internal pressure (pressure on concave side) shall have $R \leq D_a$ and $r \geq 0,06 D_a$, but in no case less than $3 s$. Dished ends of vacuum jackets are not required to meet the above restrictions on R and r except $r \geq 3 s$.

10.3.6.4.3.3 Elliptical ends

The required thickness at the thinnest point after forming of elliptical ends under pressure on the concave side shall be determined by [Formula \(10\)](#):

$$s = \frac{pD_i B}{20 \frac{K_{20}\eta}{S} - 0,2 p} \quad (10)$$

where

$$B = \frac{1}{6} \left[2 + \left(\frac{D_i}{2h} \right)^2 \right];$$

h is one-half of the length of the minor axis of the ellipsoidal end, or the inside depth of the ellipsoidal end measured from the tangent line (end-bend line), in mm.

In case of p in MPa, conversion shall be considered.

10.3.6.4.3.4 If a dished end is welded together from crown and knuckle components, the joint shall be at a sufficient distance, x , from the knuckle.

x shall be the larger of the following:

- 100 mm;
- $0,78\sqrt{R(s)}$ if the crown and knuckle are of different thickness, where s is the thickness of the knuckle component;
- $3,5 s$.

$\eta = 1,0$ may be used if the scope of testing corresponds to that specified for a design stress level equal to the permissible design stress level or in the case of one-piece ends.

10.3.6.4.3.5 If the ligament on the connecting line between adjacent openings is not entirely within the $0,6 D_a$ region, the ligament shall not be less than half the sum of the opening diameters.

10.3.6.5 Cones subject to internal or external pressure

10.3.6.5.1 Field of application

The field of application for cones is according to [Figure 2](#), where $0,001 \leq \frac{s_g - c}{D_{a1}} \leq 0,1$ and

$$0,001 \leq \frac{s_1 - c}{D_{a1}} \leq 0,1.$$

Small ends with a knuckle can be safely assessed and verified as a small end with a corner joint.

For external pressure, $|\varphi| \leq 70^\circ$.

Other cone angles may be used providing suitable calculations are carried out.

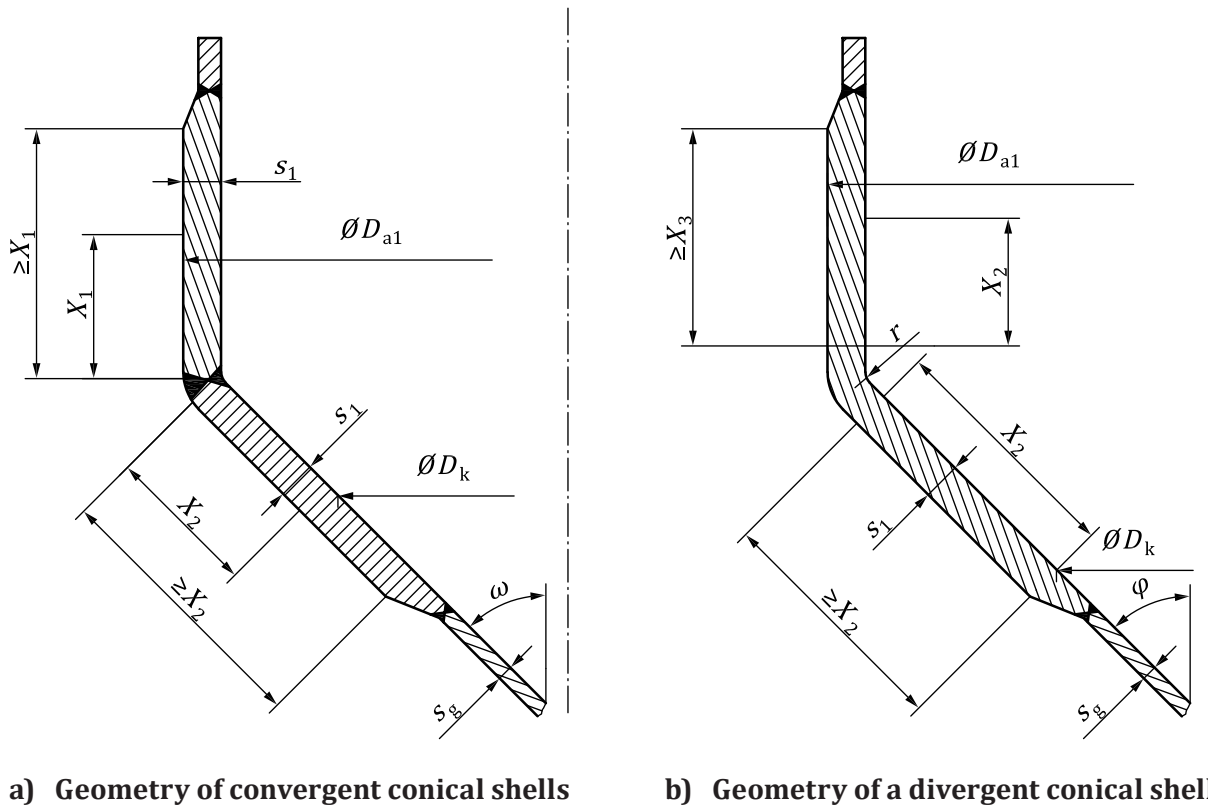

Figure 2 — Examples of cones

10.3.6.5.2 Openings

Openings outside of the corner area (Figure 3) shall be designed as follows:

- if $|\varphi| < 70^\circ$, design according to 10.3.6.5.5 using an equivalent cylinder diameter as per Formula (11):

$$D_i = \frac{D_s + d_i |\sin \varphi|}{\cos \varphi} \quad (11)$$

- if $|\varphi| \geq 70^\circ$ design according to 10.3.6.5.5.

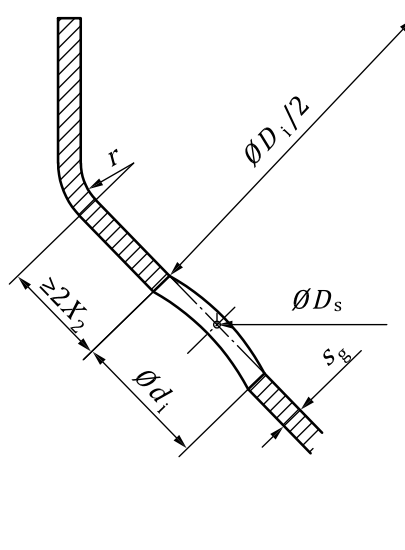

Figure 3 — Geometry of a cone opening

10.3.6.5.3 Non-destructive testing

All corner joints shall be subject to the examination required for a weld joint factor of 1,0.

10.3.6.5.4 Corner area

The corner area is that part of the cone where the dominant stresses are bending stresses in the longitudinal direction.

The corner area is defined in [Figures 2 a\)](#) and [2 b\)](#) by X_1 , X_2 , X_3 calculated from [Formulae \(12\)](#) to [\(14\)](#):

$$X_1 = \sqrt{D_{a1}(s_1 - c)} \quad (12)$$

$$X_2 = 0,7 \sqrt{\frac{D_{a1}(s_1 - c)}{\cos \varphi}} \quad (13)$$

$$X_3 = 0,5X_1 \quad (14)$$

10.3.6.5.5 Internal-pressure calculation (pressure on concave surface) $|\varphi| \leq 70^\circ$

a) Within corner area

The required wall thickness (s_1) within the corner area is calculated from [Figures 4 a\)](#) to [4 g\)](#) for the large end and [Figure 4 h\)](#) for the small end of a cone using [Formula \(15\)](#):

$$\varphi, \frac{p_s}{15K_v} \text{ and } \frac{r}{D_{a1}} \quad (15)$$

For a corner joint, the curve for $\frac{r}{D_{a1}} = 0$ shall be used.

For intermediate cone angles, linear interpolation shall be used.

b) Outside corner area

The wall thickness, s_1 , in the corner area shall not be less than the required thickness, s_g , outside the corner area.

The required wall thickness, s_g , outside the corner area, is calculated from [Formula \(16\)](#):

$$s_g = \frac{D_k p}{\left(20 \frac{K}{S} \eta\right)^{-p}} \times \frac{1}{\cos \varphi} + c \quad (16)$$

where

for the large end, $D_k = D_{a1} - 2 [s_1 + r(1 - \cos \varphi) + x_2 \sin \varphi]$;

for the small end, D_k is the maximum diameter of the cone, where the wall thickness is s_g .

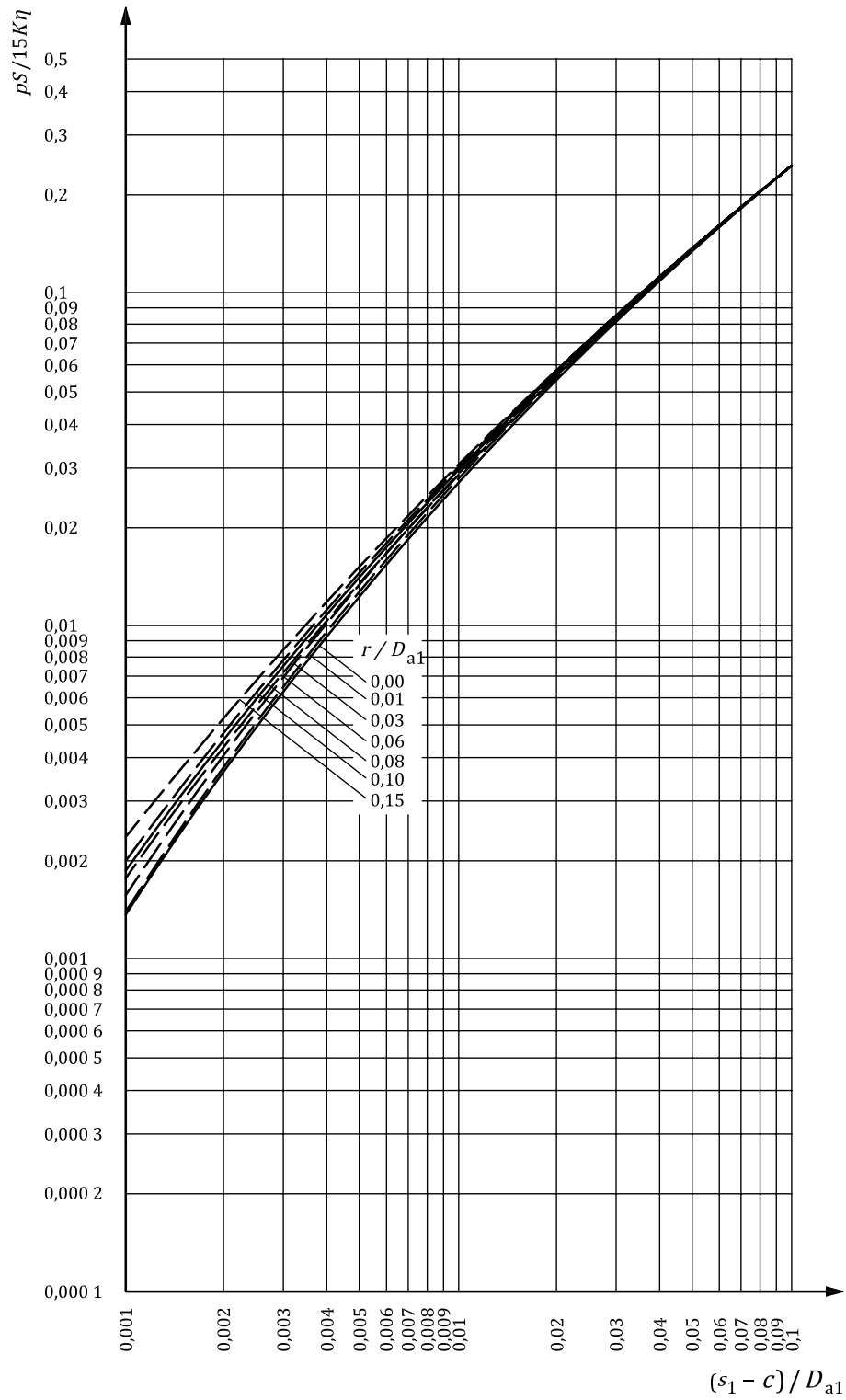

a) Permissible value $\frac{p_S}{15K\eta}$ for convergent cone with an opening angle $\varphi = 10^\circ$

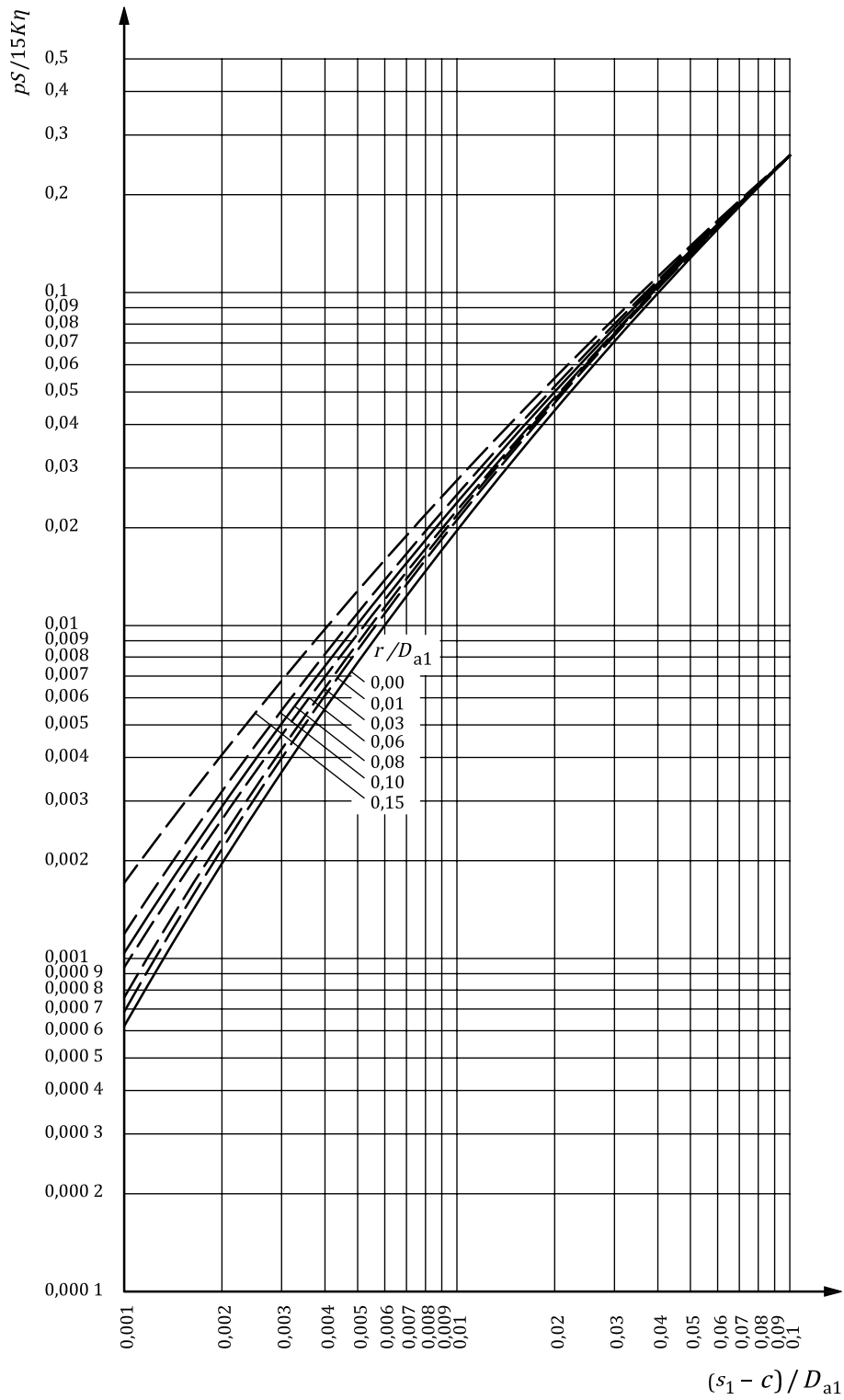

b) Permissible value $\frac{p_s}{15K\eta}$ for convergent cone with an opening angle $\varphi = 20^\circ$

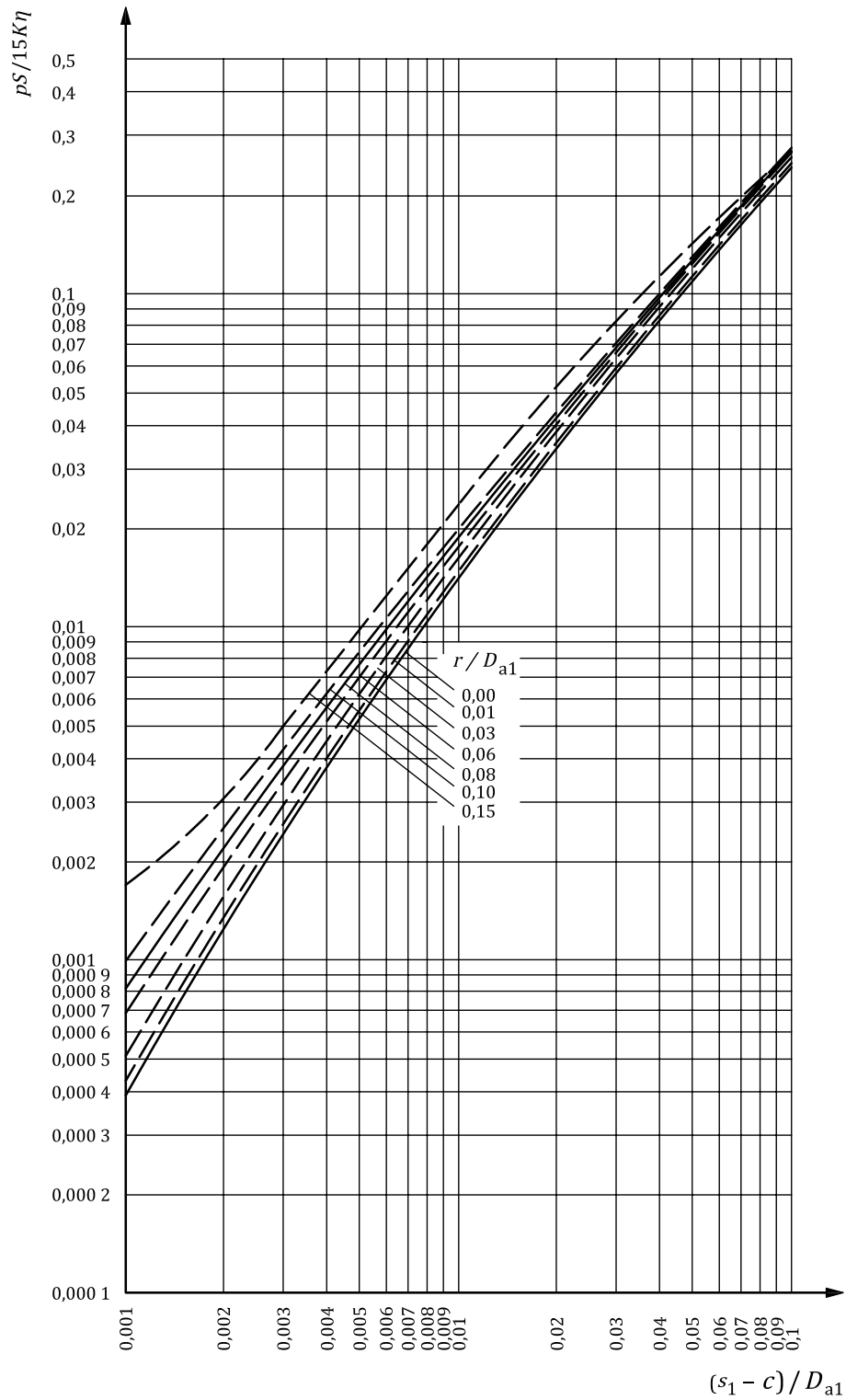

c) Permissible value $\frac{p_s}{15K\eta}$ for convergent cone with an opening angle $\varphi = 30^\circ$

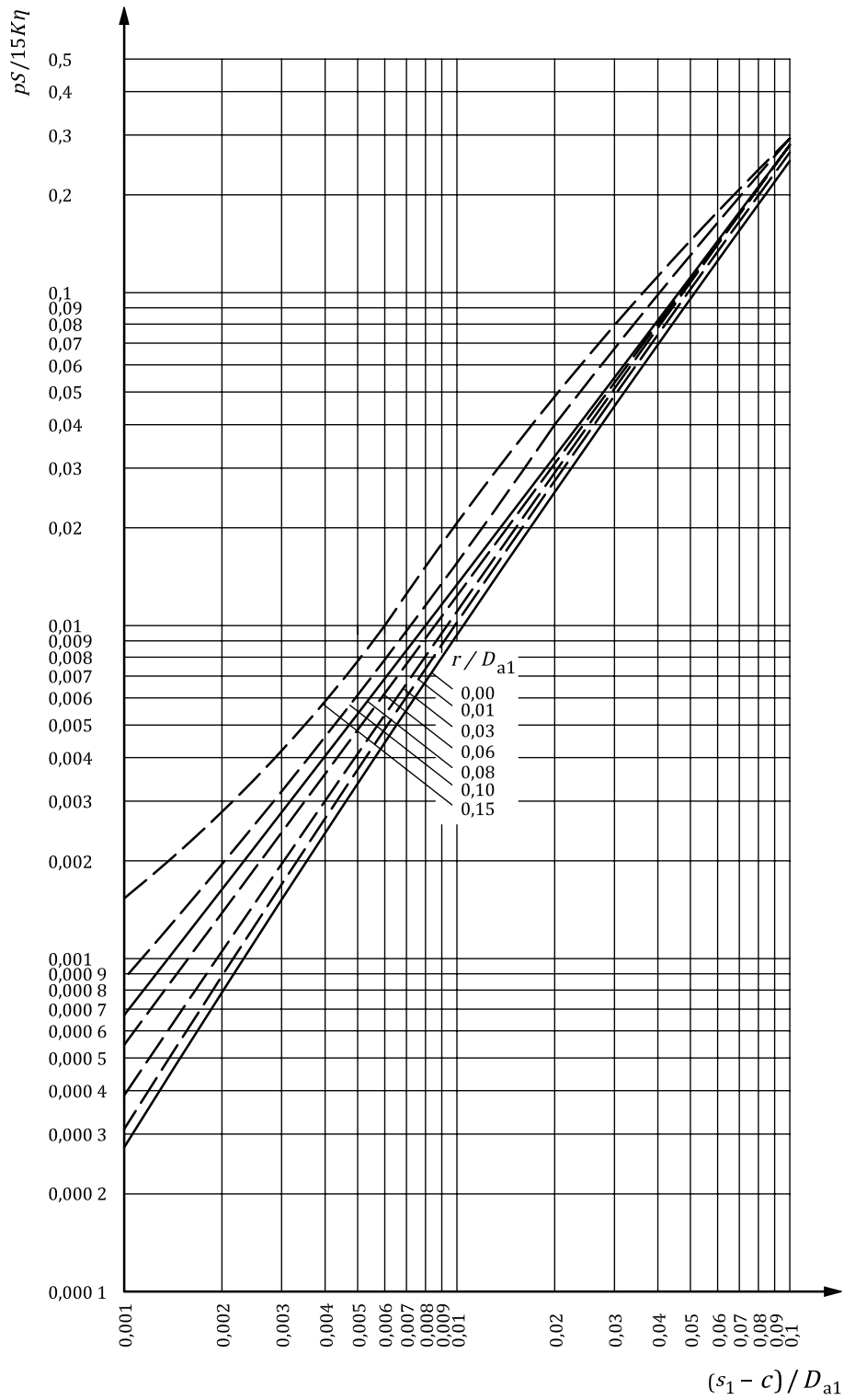

d) Permissible value $\frac{p_S}{15K\eta}$ for convergent cone with an opening angle $\varphi = 40^\circ$

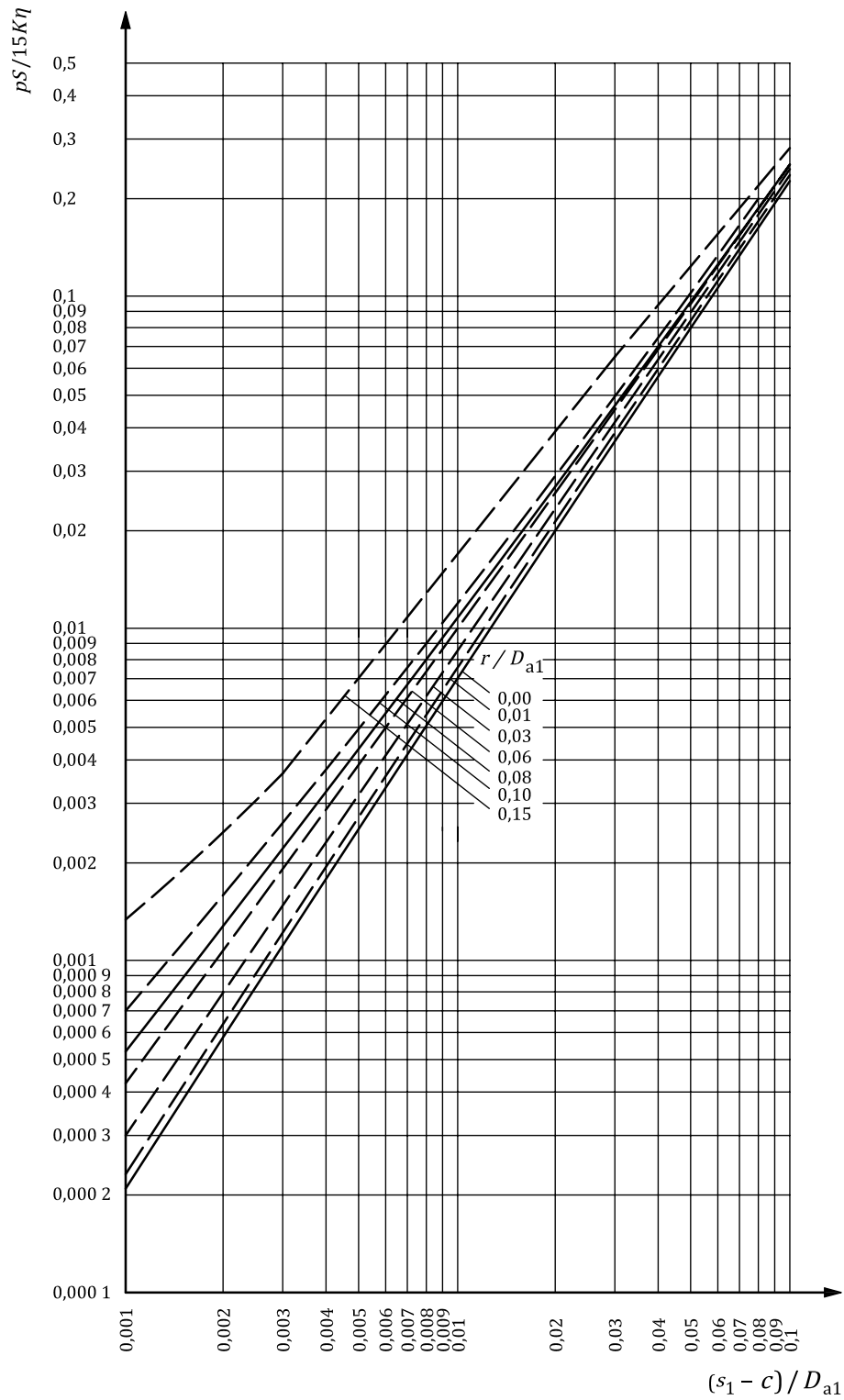

e) Permissible value $\frac{p_s}{15K\eta}$ for convergent cone with an opening angle $\varphi = 50^\circ$

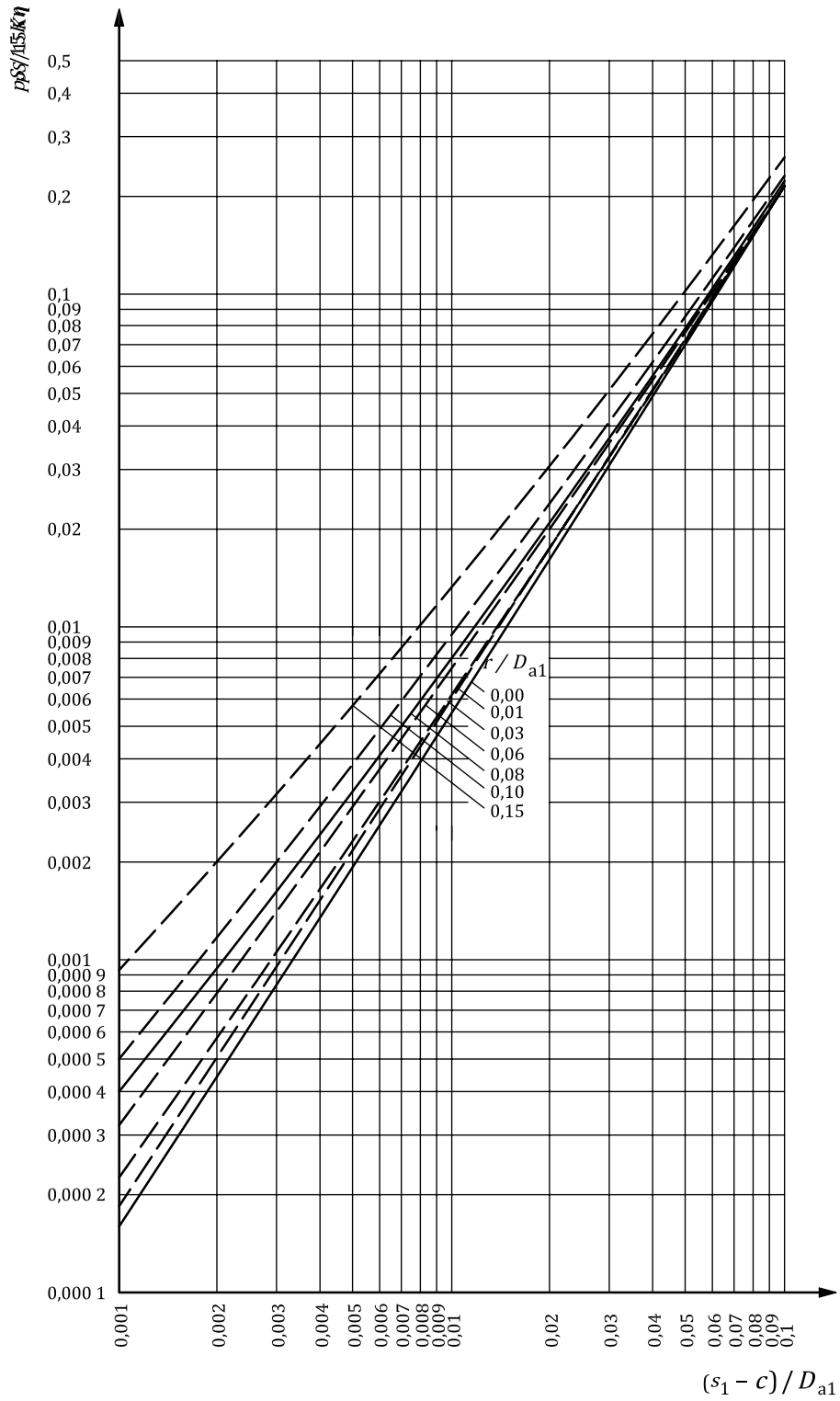

f) Permissible value $\frac{p_S}{15K\eta}$ for convergent cone with an opening angle $\varphi = 60^\circ$

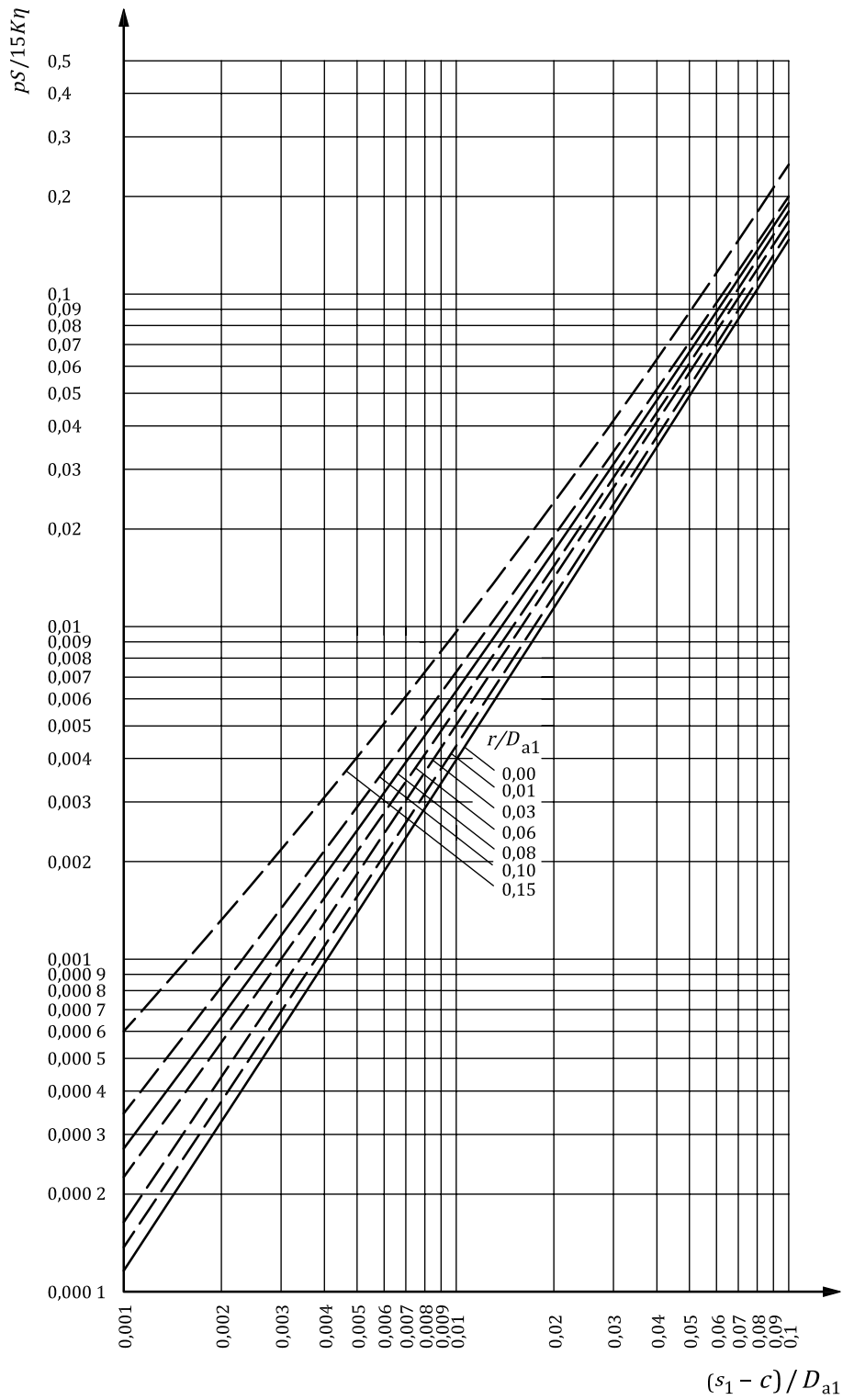

g) Permissible value $\frac{p_S}{15K\eta}$ for convergent cone with an opening angle $\varphi = 70^\circ$

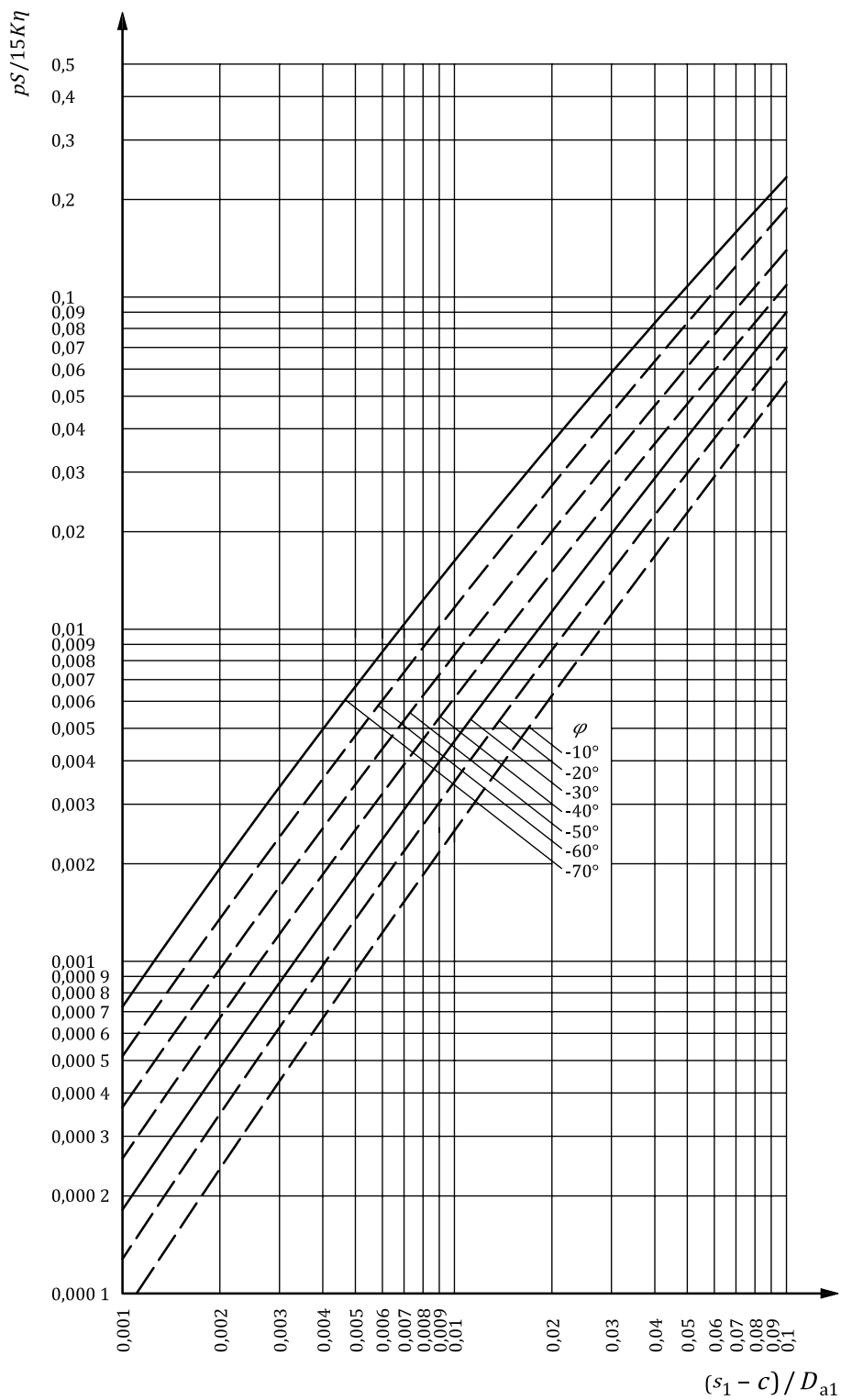

h) Permissible value $\frac{p_S}{15K\eta}$ for divergent cone (corner joint) with an opening angle $\varphi = 10^\circ$ to 70°

Key

$$X \quad \ln[(s_1 - c)/D_{a1}] \quad Z = \sum_{i=1}^4 \sum_{j=1}^2 A_{ij} \cdot X^{i-1} \cdot Y^{j-1}$$

$$Y \quad Y = r/D_{a1} \quad \frac{p_s}{15 K_\eta} = e^Z$$

Figure 4 — Wall thickness (s1) within the corner area

10.3.6.5.6 Internal-pressure calculation (pressure on the concave surface) $|\varphi| > 70^\circ$

If $r \geq 0,01 D_{a1}$, the required wall thickness is [Formula \(17\)](#):

$$s_1 = s_g = 0,3(D_{a1} - r) \times \frac{|\varphi|}{90} \times \sqrt{\frac{p}{10 \left(\frac{K}{S}\right) \eta}} + c \quad (17)$$

10.3.6.5.7 External-pressure calculation (pressure on the convex surface)

Stability against elastic buckling and plastic deformation shall be verified using [10.3.6.2](#) and an equivalent cylinder.

For the example shown in [Figure 5](#) the equivalent cylinder diameter between the knuckle and the stiffener is [Formula \(18\)](#):

$$D_a = \frac{D_{a1} + D_{a2}}{2 \cos|\varphi|} \quad (18)$$

and the equivalent cylinder length is [Formula \(19\)](#):

$$l = \frac{D_{a1} - D_{a2}}{2 \sin|\varphi|} \quad (19)$$

Depending on the relevant boundary conditions, the equivalent length between two effective stiffening sections shall be reliably estimated within the meaning of [10.3.6.2](#).

When $\varphi \geq 10^\circ$, the corner area of a large end can be considered as effective stiffening.

For small ends, the thickness in the corner area shall not be less than 2,5 times the required thickness of the conical shell with the same angle $|\varphi|$ or a stiffener shall be fitted with [Formulae \(20\)](#) and [\(21\)](#):

$$l \geq 0,010 4 S_k \frac{p(D_{a1})^4}{10E} \tan|\varphi| \quad (20)$$

$$A \geq 0,125 S_p \frac{p(D_{a1})^2}{10K} \tan|\varphi| \quad (21)$$

where

S_k (cylinder) is the safety factor to prevent elastic buckling from [10.3.2.4](#) or [10.3.3.4](#);

S_p (cylinder) is the safety factor to prevent plastic deformation from [10.3.2.4](#) or [10.3.3.4](#);

D_{a1} is the diameter according to [Figure 7 b](#)).

The shell over a width of $0,5\sqrt{D_{a1}s_1}$ can be used to calculate the moment of inertia and the area.

In addition, the corner joint should not be regarded as a classical boundary condition, i.e. the overall length should be formed from the individual meridional length of the cone and cylinder.

In addition, the cone shall be verified using [10.3.6.5.6](#) and the safety factors, S_p , for cylinders from [10.3.2.4](#) or [10.3.3.4](#) increased by 20 %. For thickness calculations in the corner area, ν shall be the value applicable for internal pressure.

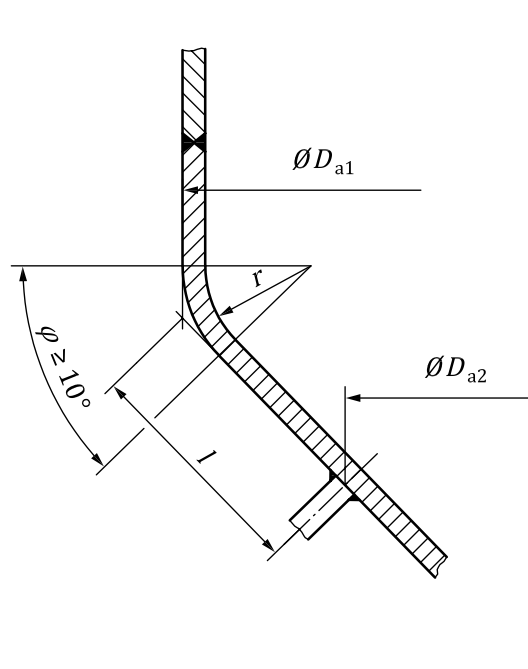

Figure 5 — Geometrical quantities in the case of loading by external pressure

10.3.6.6 Flat ends

10.3.6.6.1 Symbols and units

For the purposes of [10.3.6.6](#), the following symbols apply in addition to those given in [Clause 4](#):

- d_1, d_2 , etc., opening diameters, in mm;
- D_1 , flat-end diameters, in mm. A_s is shown in [Figure 6](#).

10.3.6.6.2 Field of application

The field of application includes welded or solid flat ends where Poisson's ratio is approximately 0,3, and [Formula \(22\)](#) and [\(23\)](#):

$$\frac{(s-c)}{D} \geq 4 \sqrt{\frac{0,0087p}{E}} \quad (22)$$

$$3 \frac{(s_e - c)}{D_1} \leq 1 \quad (23)$$

Type of flat-end design (principle only)	Conditions	Design factor C
a) Flat end	1. Knuckle radius :	0,3

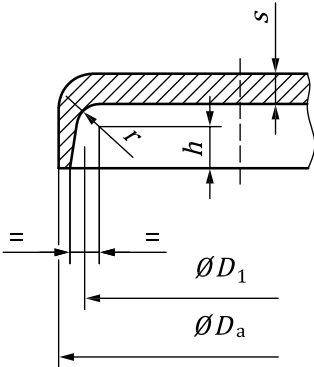
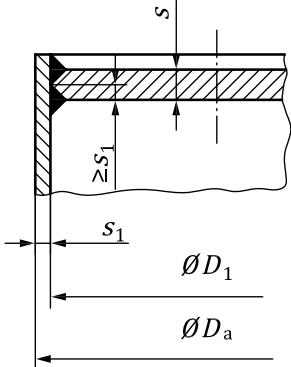
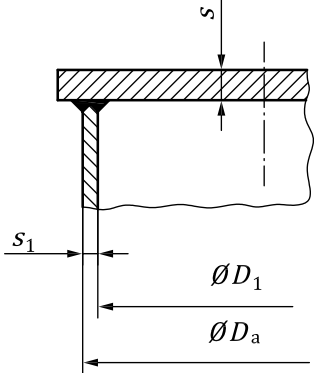
Type of flat-end design (principle only)	Conditions	Design factor <i>C</i>												
	<table border="1" data-bbox="833 271 1225 510"> <thead> <tr> <th>D_a</th> <th>r_{min}</th> </tr> </thead> <tbody> <tr> <td>up to 500</td> <td>30</td> </tr> <tr> <td>over 500 up to 1 400</td> <td>35</td> </tr> <tr> <td>over 1 400 up to 1 600</td> <td>40</td> </tr> <tr> <td>over 1 600 up to 1 900</td> <td>45</td> </tr> <tr> <td>over 1 900</td> <td>50</td> </tr> </tbody> </table> <p>and $r \geq 1,3s$ 2. cylindrical part: $h \geq 3,5 \times s$</p>	D_a	r_{min}	up to 500	30	over 500 up to 1 400	35	over 1 400 up to 1 600	40	over 1 600 up to 1 900	45	over 1 900	50	
D_a	r_{min}													
up to 500	30													
over 500 up to 1 400	35													
over 1 400 up to 1 600	40													
over 1 600 up to 1 900	45													
over 1 900	50													
b) Forged or pressed flat end 	1. Knuckle radius: $r \geq \frac{s}{3}$, however at least 8 mm 2. Cylindrical part: $h \geq s$	0,35												
c) Flat plate welded into the shell from both sides 	Plate thickness: $s \leq 3s_1$ $s > 3s_1$	0,35; 0,40												
d) Plate welded into the shell with welds at both sides of the latter 	Plate thickness: $s \leq 3s_1$ $s > 3s_1$ Only killed steels may be utilized. When plate material is employed over an area of at least $3s_1$ in the weld zone there shall be no evidence of material discontinuities in the plate.	0,40; 0,45												

Type of flat-end design (principle only)	Conditions	Design factor C
e) Flat plate welded into the shell from one side only 	Plate thickness: $s \leq 3s_1$ $s > 3s_1$	0,45;0,50

Figure 6 — Design factors for unstayed circular flat ends and plates

10.3.6.6.3 Openings

Openings are calculated in accordance with [10.3.6.6.4](#) but with the C factor multiplied by C_A , where C_A is given in [Figure 7](#).

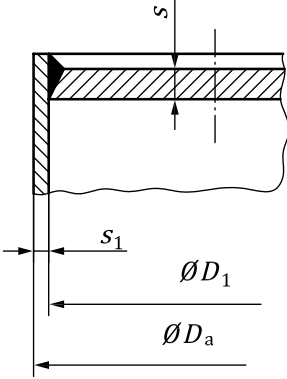
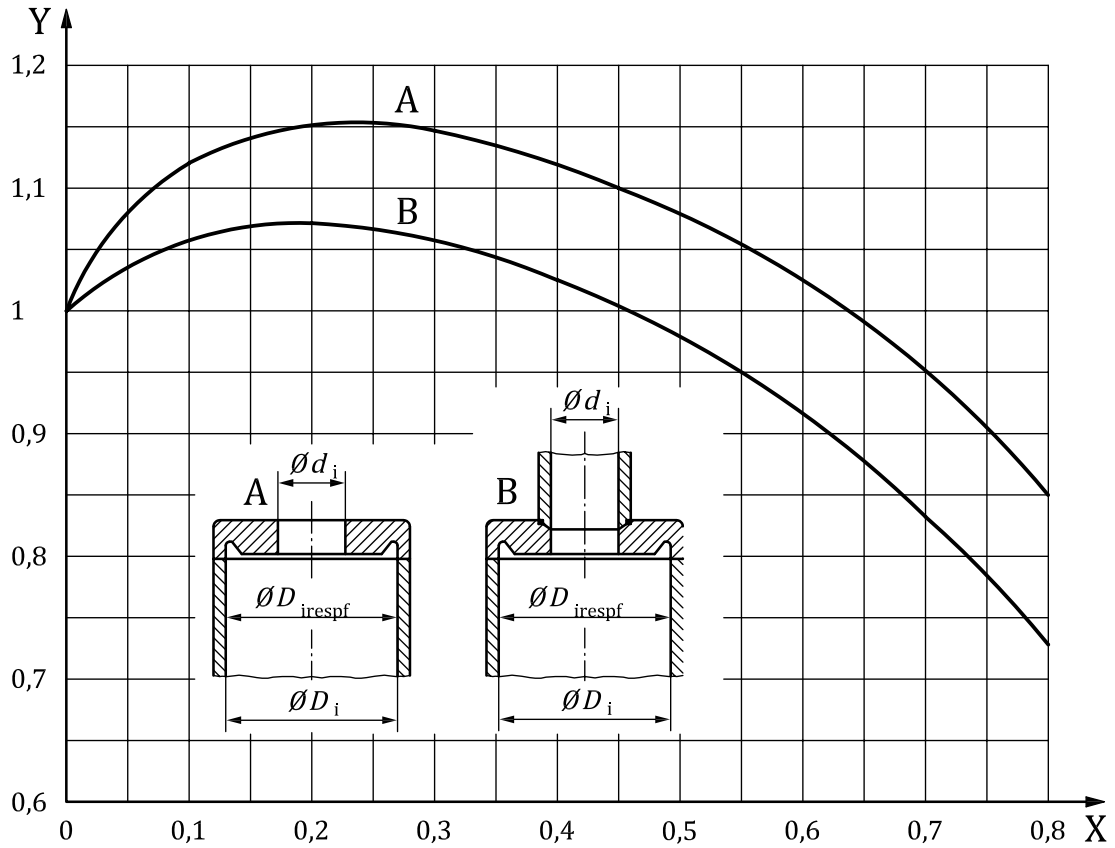

Key

X ratio d_i/D_i

Y opening factor C_A

Type A

d_i inside diameter of opening

D_i design diameter

D_{irespf} diameter of the short side of the elliptical end

f short side of elliptical end

Type B

d_i inside diameter of opening

D_i design diameter

D_{irespf} diameter of the short side of the elliptical end

f short side of elliptical end

$$C_A = \left\{ \begin{array}{l} \sum_{i=1}^6 A_i \left(\frac{d}{D_i} \right)^{i-1} \quad \left| \quad 0 < \left(\frac{d}{D_i} \right) \leq 0,8 \right. \\ \sum_{i=1}^6 A_i \left(\frac{d}{f} \right)^{i-1} \quad \left| \quad 0 < \left(\frac{d}{f} \right) \leq 0,8 \right. \end{array} \right\}$$

A_1 0,999 034 20

A_2 1,980 626 00

A_3 9,018 554 00

A_4 18,632 830 00

A_5 19,497 590 00

A_6 7,612 568 00

$$C_A = \left\{ \begin{array}{l} \sum_{i=1}^6 A_i \left(\frac{d}{D_i} \right)^{i-1} \quad \left| \quad 0 < \left(\frac{d}{D_i} \right) \leq 0,8 \right. \\ \sum_{i=1}^6 A_i \left(\frac{d}{f} \right)^{i-1} \quad \left| \quad 0 < \left(\frac{d}{f} \right) \leq 0,8 \right. \end{array} \right\}$$

A_1 1,001 003 44

A_2 0,944 284 68

A_3 4,312 102 00

A_4 8,389 435 00

A_5 9,206 283 84

A_6 3,694 941 96

Figure 7 — Opening factor, C_A , for flat ends and plates without additional marginal moment

10.3.6.6.4 Calculation

The required minimum wall thickness of a circular flat end is [Formula \(24\)](#):

$$s = CD_1 \sqrt{\frac{0,1pS}{K}} + c \quad (24)$$

where C and D_1 are taken from [Figure 6](#).

The required minimum wall thickness of a rectangular or elliptical flat end is [Formula \(25\)](#):

$$s = CC_e \sqrt{\frac{0,1pS}{K}} + c \quad (25)$$

where C_e is taken from [Figure 8](#).

10.3.6.7 Openings in cylinders, spheres and cones

10.3.6.7.1 Field of application

Round openings and the reinforcement of round openings in cylinders, spheres and cones within the limits of [Formulae \(26\)](#) and [\(27\)](#):

$$0,002 \leq \frac{(s-c)}{D_a} \leq 0,1 \quad (26)$$

$$\frac{(s-c)}{D_a} < 0,002 \text{ is acceptable if } \frac{d_i}{D_a} \leq \frac{1}{3} \quad (27)$$

These rules only apply to cones if the wall thickness is determined by the circumferential stress.

Additional external forces and moments are not covered by this subclause and should be considered separately where necessary.

These design rules permit plastic deformations of up to 1 % at highly stressed local areas during pressure test. Openings should therefore be carefully designed to avoid abrupt changes in geometry.

The design rules for non-perpendicular nozzles shall be based on a perpendicular nozzle, using the dimension of the major elliptical axis.

10.3.6.7.2 Reinforcement methods

Openings may be reinforced by one or more of the following typical but not exclusive methods:

- increase of shell thickness;
- set-in or set-on ring reinforcement;
- pad reinforcement (see [Figure 9](#));
- increase of nozzle thickness (see [Figures 10](#) and [11](#));
- pad and nozzle reinforcement.

Where ring or pad reinforcement is used on the inner vessel, the space between the two fillet welds shall be vented into the vacuum interspace.

10.3.6.7.3 Design of openings

All nozzles shall be attached to the vessel wall with a full penetration weld unless the attachment weld is maintained at atmospheric temperatures at all times or the weld is not subjected to thermal cycling.

The fillet weld on a reinforcing pad shall have a minimum throat thickness of half of the pad thickness.

The throat thickness of a fillet weld of each nozzle to shell weld shall be not less than the required thickness of the thinner part.

Where the strength of the reinforcing material is lower than the strength of the shell material, an allowance in accordance with [10.3.6.7.4](#) shall be made in the design calculations. If the strength of the reinforcing material is higher than the strength of the shell material, no allowance for the increased strength is permitted.

10.3.6.7.4 Calculation

[Annex I](#) gives two alternative calculation methods. Both methods give comparable results and shall be equally accepted.

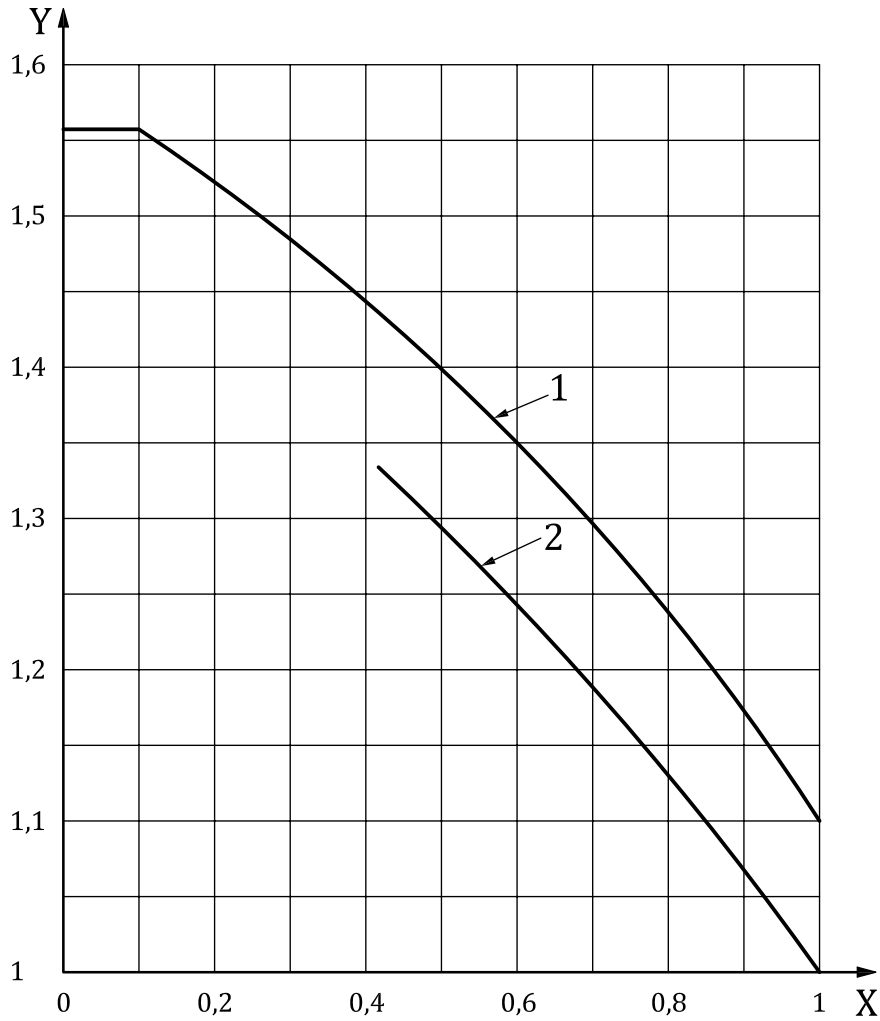

Key

- 1 rectangular plate
- 2 elliptical plate

Rectangular plates

f short side of the rectangular plate

e long side of the rectangular plate

Elliptical plates

f short side of the elliptical plate

e long side of the elliptical plate

$$C_e = \begin{cases} \sum_{i=1}^4 A_i \left(\frac{f}{e}\right)^{i-1} & \left| \quad 0,1 < \left(\frac{f}{e}\right) \leq 1,0 \right. \\ 1,562 & \left| \quad 0 < \left(\frac{f}{e}\right) \leq 0,1 \right. \end{cases}$$

$$C_e = \begin{cases} \sum_{i=1}^4 A_i \left(\frac{f}{e}\right)^{i-1} & \left| \quad 0,43 < \left(\frac{f}{e}\right) \leq 1,0 \right. \end{cases}$$

- A_1 1,589 146 00
- A_2 -0,239 349 90
- A_3 -0,335 179 80
- A_4 0,085 211 76

- A_1 1,489 146 00
- A_2 -0,239 349 90
- A_3 -0,335 179 80
- A_4 0,085 211 76

Figure 8 — Design factor, C_e , for rectangular or elliptical flat plates

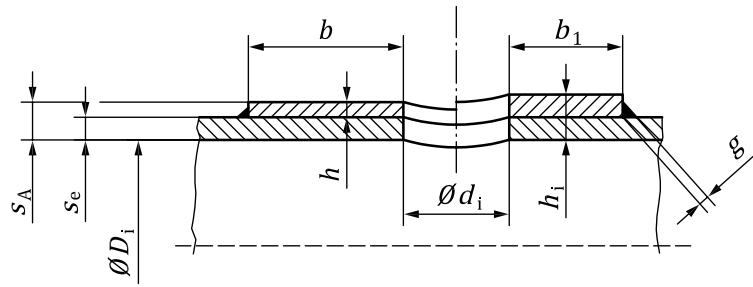

Figure 9 — Pad reinforcement

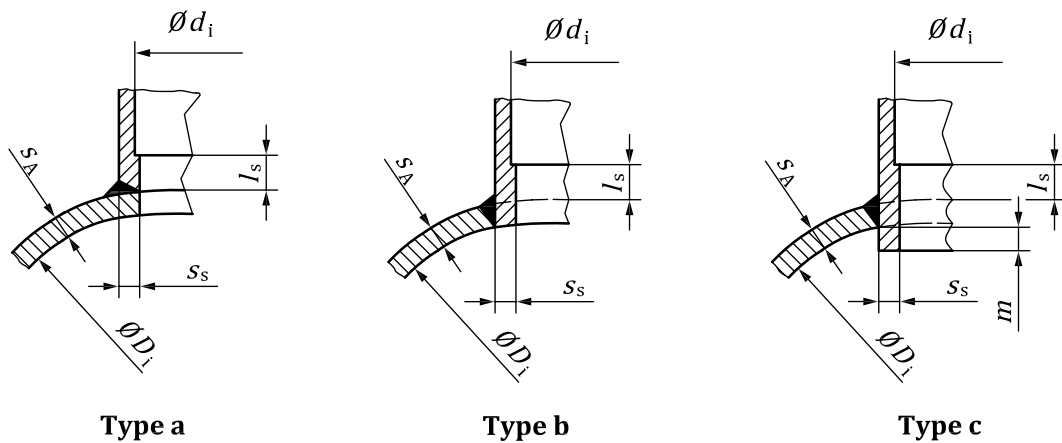

Figure 10 — Nozzle reinforcement

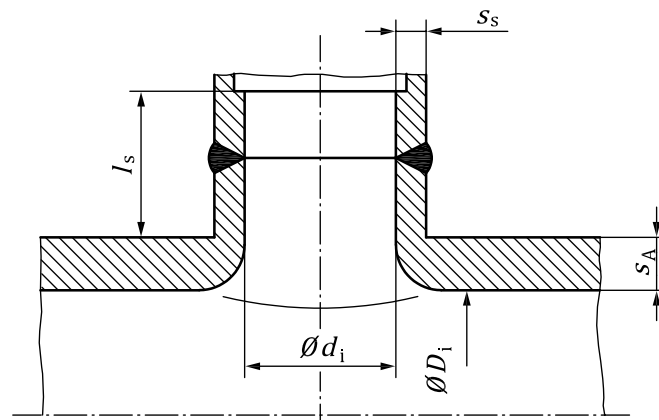

Figure 11 — Necked-out opening

10.3.7 Calculations for operating loads

Unless the design has been validated by experiment, calculations in addition to those in [10.3.6](#) may be required to ensure that stresses due to operating loads are within acceptable limits. All load conditions expected during service shall be considered (see [10.2.3](#)).

In these calculations, equivalent static loads shall be substituted for static plus dynamic loads.

The analysis shall take account of gross structural discontinuities.

[Annex B](#) or ASME VIII-2 provides terminology and acceptable stress limits when an elastic stress analysis is performed.

Acceptable calculation methods include:

- finite element;
- finite difference;
- boundary element;
- recognized text books, codes and standards.

Planned and controlled experimental means may be used in order to confirm these calculations, for example by application of strain gauges to verify stress levels.

11 Fabrication

11.1 General

11.1.1 The manufacturer, or his or her subcontractor, shall have equipment available to ensure manufacture and testing in accordance with the design.

11.1.2 The manufacturer shall maintain:

- a system of material traceability for pressure-bearing parts used in the construction of the inner vessel;
- design dimensions within specified tolerances;
- necessary cleanliness of the inner vessel, associated piping and other equipment which can come in contact with the cryogenic fluid.

11.2 Cutting

Material may be cut to size and shape by thermal cutting, machining, cold shearing or other appropriate method. Thermally cut material shall be dressed back by machining or grinding.

11.3 Cold forming

11.3.1 Austenitic stainless steel

Heat treatment after cold forming is not required in any of the following cases:

- a) for operating temperatures down to $-196\text{ }^{\circ}\text{C}$:
 - 1) the test certificate for the base material shows an elongation at fracture A_5 of not less than 30 %; and
 - 2) the cold-forming deformation is not more than 15 % or it is demonstrable that the residual elongation is not less than 15 %;

Cold forming deformation may be calculated according to [Formula \(28\)](#):

$$F = 100 \ln \frac{D_{b(x)}}{D_e - 2e} \quad (28)$$

where

e is the thickness of the initial product;

$D_{b(x)}$ is the diameter of the initial product;

D_e is the external diameter of the final product;

\ln is the natural logarithm (addition of the formula to conform with ISO 21009-1).

- b) for operating temperatures below -196 °C: the cold-forming deformation is less than or equal to 15 % and it is demonstrated that the residual elongation is not less than 15 %;
- c) for cold formed heads, the test certificate for the base material shows an elongation at fracture A_5 :
 - not less than 30 % in the case of wall thicknesses not more than 15 mm at design temperatures down to -196 °C;
 - not less than 35 % in the case of wall thicknesses more than 15 mm at design temperatures down to -196 °C;
 - not less than 40 % at design temperatures below -196 °C.

Where heat treatment is required, this shall be carried out in accordance with the material standard.

Heat treatment of cold formed heads should be performed for liquid hydrogen service or for cryogenic gases containing unacceptable levels of H_2S . (see ISO 11114-1).

11.3.2 Ferritic steel

The following requirements for post-forming heat treatment shall be observed:

- a) material for the outer jacket, including cold-formed ends with or without jogged joints, does not require post-forming heat treatment;
- b) 9 % Ni steel requires post-forming heat treatment where cold-forming deformation exceeds 5 %. Fully certified quenched and tempered or double normalized and tempered 9 % Ni steel shall be stress relieved at 560 °C to 580 °C. Forming and stress relieving may be performed in several stages. A test piece taken from the parent material that accompanies the formed part through all stages of heat treatment shall be tested after all heat treatment is complete to demonstrate that the material mechanical properties conform to the requirements of the material standard;
- c) for the following ferritic steels used for the inner vessel, post-forming heat treatment is not required where the forming deformation is not more than 5 %:
 - 1) nickel-alloyed steels, suitable for low-temperature use;
 - 2) carbon and carbon-manganese steels:
 - where $R_m \leq 530$ N/mm²;
 - or where $530 < R_m \leq 650$ N/mm² and $R_{0,002} \leq 360$ N/mm².

When heat treatment is required, suitable heat treatments after cold forming are normalizing, normalizing (double) plus tempering, quenching plus tempering or solution annealing.

Parameters given by the base-material manufacturer in the test certificate shall be taken as an indication or recommendation for heat treatments except that other heat treatments may be applied if the procedure is qualified and the product or a test piece representing the product is tested after forming and heat treatment.

11.3.3 Aluminium or aluminium alloy

Cold-formed ends made from aluminium or aluminium alloy do not normally require post-forming heat treatment, unless there is a risk of stress corrosion in service. Treatment shall be carried out in accordance with the material standard.

11.4 Hot forming

11.4.1 General

Forming shall be carried out in accordance with a written qualified procedure. The forming procedure shall specify the heating rate, the holding temperature, the temperature range and time for which the forming takes place and shall give details of any heat treatment to be given to the formed part.

11.4.2 Austenitic stainless steel

Material shall be heated uniformly in an appropriate atmosphere without flame impingement, to a temperature not exceeding the recommended hot-forming temperature of the material. When forming is carried out after the temperature of the material has fallen below 900 °C the requirements of [11.3.1](#) shall be complied with.

11.4.3 Ferritic steel

The following requirements for post-forming heat treatment shall be observed:

- a) 9 % Ni steel that is hot formed shall be double normalized and tempered, or quenched and tempered in accordance with the material standard to establish the material properties specified therein. Test piece(s) shall be provided and tested in accordance with the material standard;
- b) ferritic steel that is hot formed shall be heat treated in accordance with the material standard to establish the material properties specified therein:
 - air-quenched steels shall be tempered subsequently;
 - test pieces shall be provided and tested in accordance with the material standard;
 - for normalized steels a post-forming heat treatment is not necessary if the hot forming is done within the specified temperature range, specified in the material standards; further test pieces are not required.

11.4.4 Aluminium or aluminium alloy

Post-forming heat treatment may be omitted if evidence in the form of a procedure qualification can be provided showing that the elongation at fracture A_5 of the formed material is not less than 10 %.

11.5 Manufacturing tolerances

11.5.1 General

The recommendations in this subclause are suitable for vessels subjected to predominantly static loads. For fatigue loads, the manufacturing tolerances shall meet the recommendations of the applied design codes/standards.

To avoid fatigue damage in case of cyclic loading, more severe fabrication, inspection and testing requirements are needed for critical areas of the pressure vessels, see also [12.3.4.2](#). For cyclic loaded vessels the absence of surface imperfections and the necessity of smooth transitions are essential. Only smooth transitions are allowed. Similarly, shape imperfections such as peaking are absolutely critical and the maximum permissible peaking of the applied standard/code, or the value permitted in the fatigue analysis, shall not be exceeded

11.5.2 Plate alignment

Except where a tapered transition is provided, misalignment of the surfaces of adjacent plates at welded seams shall be for longitudinal and circumferential seams, not more than 25 % of the thickness of the thinner plate up to a maximum of 3 mm.

Where a taper is provided between the surfaces, this shall have a slope of not more than 18,4°. The taper may include the width of the weld, the lower surface being built-up with added weld metal if necessary. Where material is removed from a plate to provide a taper, the thickness of either plate shall not be reduced below that required for the design.

The distance between either surface of the thicker plate and the centre line of the thinner plate of tapered seams shall be for longitudinal and circumferential seams, not less than 35 % of the thickness of the thinner plate.

In no case shall the surface of any plate lie between the centre lines of the two plates.

These requirements are illustrated in [Figure 12](#).

The following nomenclature applies:

- h, h_1, h_2 : surface misalignments;
- t : thickness of the thinner plate;
- e : distance from the surface of the thicker plate to the centre line of the thinner plate.

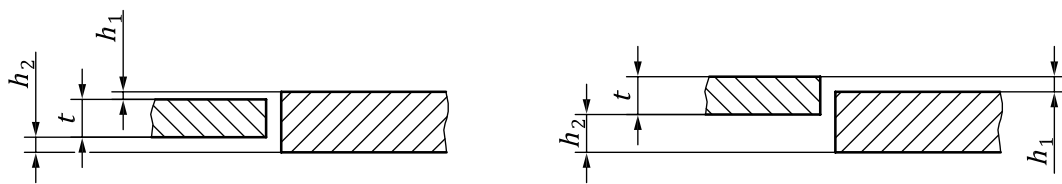

a) Seams which do not require a taper

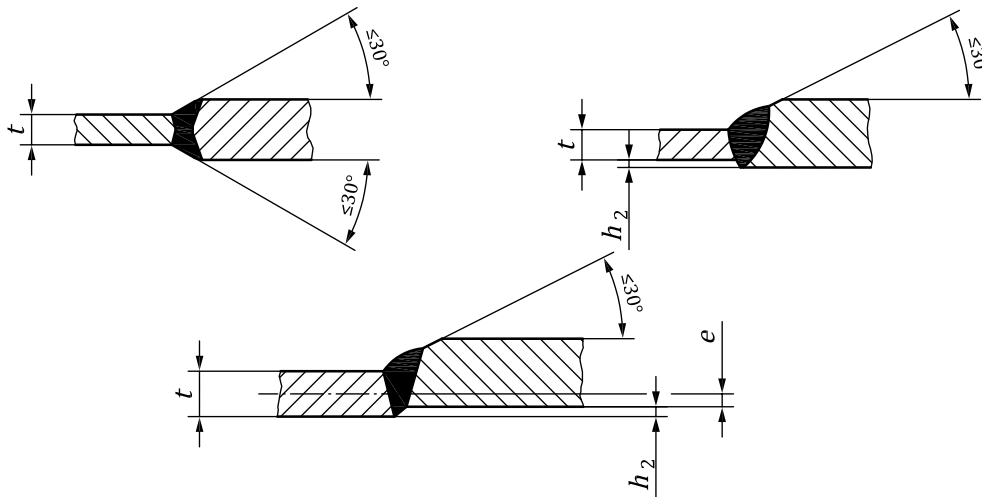

b) Seams which do require a taper

NOTE 1 For longitudinal and circumferential seams which do not require a taper: $h_1 \leq 0,25t$ and $h_2 \leq 0,25t$.

NOTE 2 For longitudinal and circumferential seams which require a taper: $e = \frac{t}{2} - h_2 \geq 0,35t$.

Figure 12 — Plate alignment

11.5.3 Thickness

The thickness of the vessel shall not be less than the design thickness. This shall be taken as the thickness of the vessel after manufacture, and any variations in thickness shall be gradual.

11.5.4 Dished ends

The knuckle radius shall not be less than specified and any variation of crown radius shall not be abrupt but shall adhere to the following tolerances: $\begin{matrix} +0,625 \\ -1,25 \end{matrix}$ %.

11.5.5 Cylinders

11.5.5.1 The actual circumference shall not deviate from the circumference calculated from the specified diameter by more than 1,5 %.

11.5.5.2 The out of roundness, u , calculated from [Formula \(29\)](#):

$$u = \frac{200(D_{\max} - D_{\min})}{D_{\max} + D_{\min}} \% \tag{29}$$

shall be not more than the values shown in [Table 4](#).

Table 4 — Permitted out of roundness

Wall thickness to diameter ratio	Permitted out of roundness for	
	internal pressure	external pressure
$s/D = 0,01$	2,0 %	1,5 %
$s/D > 0,01$	1,5 %	1,5 %

The determination of the out of roundness need not consider the elastic deformation due to the dead weight of the pressure vessel. At nozzle positions, a greater out of roundness may be permitted if it can be justified by calculation or strain gauge measurement. Single dents or knuckles shall be within the tolerances. Dents shall be smooth and their depth which is the deviation from the generatrix of the shell shall not exceed 1 % of their length or 2 % of their width respectively. Greater dents and knuckles are permissible provided they have been proven admissible by calculation or by strain measurements.

Irregularities in profile (checked by a 20° gauge) shall not exceed 2 % of the gauge length. This maximum value may be increased by 25 % if the length of the irregularities does not exceed one-quarter of the length of the shell part between two circumferential seams with a maximum of 1 m. Greater irregularities require proof by calculation or strain gauge measurement that the stresses are permissible (see [Figure 13](#)).

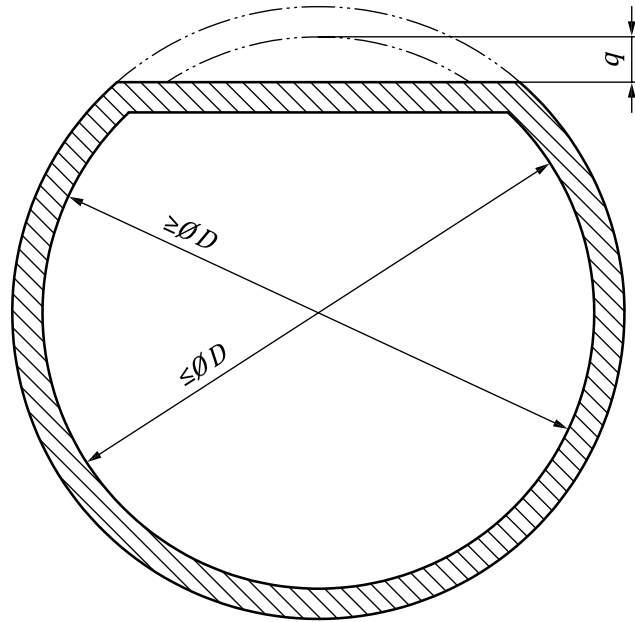

NOTE Definitions:

u equivalent to $\frac{4}{D_a} \times q \times 100$

Limitations:

$u \leq 15 \%$

$q \leq 0,003\ 75D_a$

Figure 13 — Allowable shape imperfections

Furthermore, where irregularity in the profile occurs at the welded seam and is associated with “flats” adjacent to the weld the irregularity in profile or “peaking” shall not exceed the values given in [Table 5](#).

A conservative method of measurement (covering peaking and ovality) shall be by means of a 20° profile gauge (or template).

The use of such a profile gauge is illustrated in [Figure 14](#). Two readings shall be taken, P_1 and P_2 , on each side of the seam, at any particular location. The maximum peaking is taken as being equivalent to $0,25 (P_1 + P_2)$.

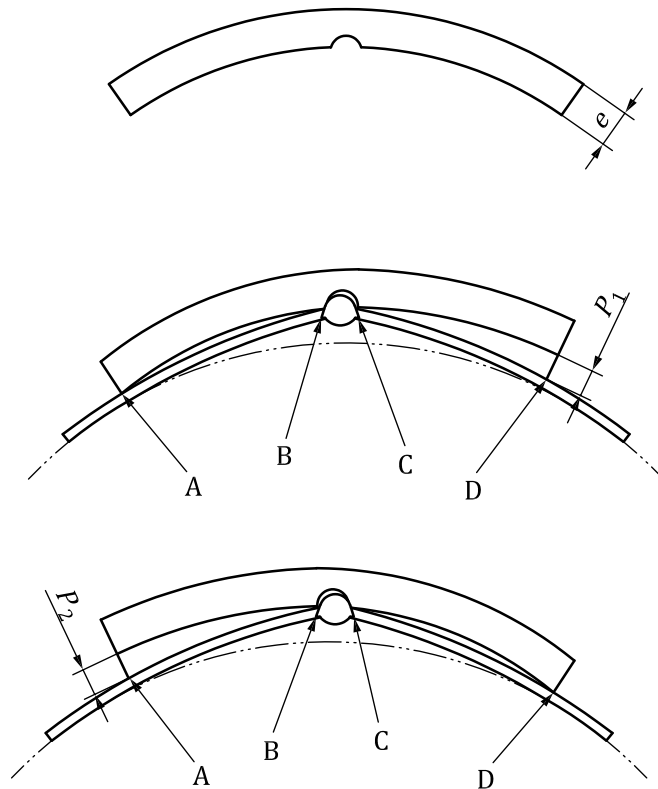

Figure 14 — Gauge details

Measurements should be taken at approximately 250 mm intervals on longitudinal seams to determine the location with the maximum peaking value. Use of other types of gauges such as bridge gauges or needle gauges are not prohibited. The maximum peaking value permitted is given in [Table 5](#).

Table 5 — Maximum permitted peaking

Dimensions in millimetres

Vessel ratio wall thickness s to diameter D	Maximum permitted peaking
$s/D \leq 0,025$	5
$s/D > 0,025$	10

For all ratios, a maximum permitted peaking is e .

For cylinders subject to external pressure and where the circumference has a flattened portion, it shall be demonstrated that the shell has sufficient strength to avoid plastic deformation where the depth of flattening is more than 0,4 % of the outside diameter of the cylinder. The depth of flattening shall be measured as a deviation from the normal curvature or from the line of the cylindrical shell. Adequate strength may be determined by calculation in accordance with [Formula \(14\)](#), using a value of u determined with [Formula \(30\)](#):

$$u = \frac{400}{D_a} \times q \quad (30)$$

where

q is the depth of flattening, in mm;

D_a is the external diameter of the cylinder, in mm.

11.5.5.3 Departure of the cylinder axis from a straight line shall be not more than 0,5 % of the cylindrical length, except where required by the design.

11.6 Welding

11.6.1 General

The manufacturer shall fulfil the requirements of ISO 3834-2 or equivalent.

The welding method shall be appropriate and shall be carried out by qualified welders and/or operators, the materials shall be compatible, and there shall be verification by a welding procedure test.

11.6.2 Qualification

Welding procedures shall be approved in accordance with ISO 15614-1, ISO 15614-2, ISO 15613 or ISO 14732 as applicable, or with equivalent standards. Welders and welding operators shall be qualified in accordance with ISO 9606-1 or ISO 9606-2 or with ISO 14732 as applicable or with equivalent standards.

11.6.3 Temporary attachments

Temporary attachments welded to pressure-bearing parts shall be kept to a practical minimum.

Temporary attachments welded directly to pressure-bearing parts shall be compatible with the immediately adjacent material.

It is permissible to weld dissimilar metal attachments to intermediate components, such as pads, which are connected permanently to the pressure-containing part. Compatible welding materials shall be used for dissimilar metal joints.

Temporary attachments shall be removed from the inner vessel prior to the first pressurization. The removal technique shall avoid impairing the integrity of the inner vessel and shall be by chipping or grinding. Any rectification necessary by welding of damaged regions shall be undertaken in accordance with an approved welding procedure.

The area of the inner vessel from where the temporary attachments have been removed shall be dressed smooth and examined by appropriate non-destructive testing.

Any attachments on the outer jackets may be removed by thermal cutting as well as by the methods described above.

11.6.4 Welded joints

11.6.4.1 Some specific weld details appropriate to vessels conforming to this document are given in [Annex E](#). These details show sound and currently accepted practice. It is not intended that these be mandatory, nor should they restrict the development of welding technology in any way.

The manufacturer, in selecting an appropriate weld detail, shall consider:

- the method of manufacture;
- the service conditions;
- the ability to carry out necessary non-destructive testing.

Weld details may be used provided their suitability is proven by procedure approval according to ISO 15614-1, ISO 15614-2 or ISO 15613 as applicable.

To avoid sub-standard welding of ferritic steels, excess residual magnetism shall be avoided.

11.6.4.2 Where any part of a vessel is made in two or more courses, the longitudinal weld seams of adjacent courses shall be staggered. A minimum of 100 mm is recommended. Joggled joints may be used in stainless steels for circumferential welds only and plate thickness up to 8 mm. Backing strips may be used for circumferential welds only with no thickness restriction. When forming the joggled joints, reduction in toughness shall be considered for low temperature.

11.6.4.3 As the mechanical characteristics of work-hardened austenitic stainless steels can be adversely affected if the material is not welded properly, the additional requirements below shall be applied:

- the heat input during welding shall be not more than 1,5 kJ/mm per bead to be verified in the procedure qualification test;
- the material shall cool to a temperature of not more than 200 °C between passes;
- the material shall not be heat treated after welding.

See also [C.2.7](#), [C.2.8](#), [C.2.9](#), and [C.2.10](#).

11.7 Non-welded joints

Where non-welded pressure-retaining joints are made between metallic materials and/or non-metallic materials, procedures shall be established in a manner similar to that used in establishing welding procedures, and these procedures shall be followed for all such joints. Similarly, operators shall be qualified in such procedures, and only qualified personnel shall then carry out these procedures.

12 Inspection and testing

12.1 Quality plan

12.1.1 General

A quality plan forming part of the quality system shall include, as a minimum, the inspection and testing stages listed in [12.1.2](#).

12.1.2 Inspection stages during manufacture of an inner vessel

The following inspection stages shall be conducted during the manufacture of an inner vessel:

- verification of material test certificates and correlation with materials;
- approval of weld procedure qualification records;
- approval of welders' qualification records;
- examination of material cut edges;
- examination of setup of seams for welding including dimensional check;
- examination of weld preparations, tack welds;
- visual examination of welds;
- verification of non-destructive testing;
- testing production control test plates for welds and, where required, for formed parts after heat treatment;
- verification of cleaning of inside surface of vessel;
- examination of completed vessel including dimensional check;

- pressure test.

If cold stretching is used, inspection scope and requirements should be adapted as specified in [D.5.5](#).

12.1.3 Additional inspection stages during manufacture of a large transportable cryogenic vessel

The following inspection stages shall be conducted during the manufacture of a large transportable cryogenic vessel:

- verification of cleanliness and dryness of the cryogenic vessel (see ISO 23208);
- visual examination of welds not covered by [12.1.2](#);
- leakproofness tests ensuring the integrity of vacuum, and leak testing of external piping when it is connected to the inner vessel;
- leak test of external piping;
- check of documentation and installation of pressure-relief device(s);
- check of installation of vacuum-space relief device;
- check of nameplate and any other specified markings;
- examination of completed vessel including dimensional check.

12.2 Production control test plates

12.2.1 Requirements

Production control test plates shall be produced and tested for the inner vessel as follows:

- a) one test plate per vessel shall be used for each welding procedure on longitudinal joints except as specified in b);
- b) after 10 sequential test plates to the same procedure have successfully passed the tests, testing may be reduced to one test plate per 50 m of longitudinal joint for 9 % Ni and ferritic steels and to one test plate per 100 m for other metals, one test plate per 130 m for other metals, provided the joints are made within any three-month period.

Production control test plates are not required for the outer jacket.

The results of the tests shall be as follows:

- weld tensile test (T): R_{eT} , R_m and A_5 of the test specimens shall normally not be less than the corresponding specified minimum values for the parent metal, or the agreed values of the welding procedure approved;
- impact test (IW, IH): this test shall be performed in accordance with ISO 21028-1 and ISO 21028-2;
- bend test (BF, BR, BS): the testing and the test requirements shall comply with ISO 15614-1 for steels and with ISO 15614-2 for aluminium and its alloys;
- macro etch (Ma): the macro etch shall show sound build-up of beads and sound penetration.

12.2.2 Extent of testing

The number and type of test specimens to be taken from the test plate is dependent on material and thickness, and shall be in accordance with the requirements in [Tables 7](#) and [8](#) for the particular material and thickness applicable.

NOTE The symbols for [Tables 7](#) and [8](#) are given in [Table 6](#).

The test plate shall be of sufficient size to allow for the required specimens including an allowance for retests.

Prior to cutting the test piece, non-destructive testing of the test plate may be applied in order that the test specimens are taken from sound areas.

Table 6 — Test specimens

Designation	Symbol
Face bend test to ISO 5173	BF
Root bend test to ISO 5173	BR
Side bend test to ISO 5173	BS
Tensile test to ISO 4136	T
Impact test: weld deposit to ISO 9016	IW
Impact test: HAZ to ISO 9016	IH
Macro etch	Ma

Table 7 — Testing of production test plates for steels

Group	<i>se</i> in mm	Test specimens
Fine-grain steels normalized or thermo-mechanically treated	$se \leq 12$	1 BF, 1 BR, 1 T, 1 Ma
	$12 < se \leq 35$	3 IW, 3 IH, 1 T, 1 Ma
Ni steels up to 9 % Ni	$se \leq 12$	1 BF, 1 BR, 1 T, 1 Ma
	$12 < se$	3 IW, 3 IH, 1 T, 1 Ma
Austenitic stainless steels	$se \leq 12$	1 BF, 1 BR, 1 T, 1 Ma
	$12 < se$	3 IW, 1 T, 1 Ma
Impact test requirement for steels used below 77 K	$se > 2,5$	3 IW, 1 T, 1 Ma

Table 8 — Testing of production test plates for aluminium

Group	<i>se</i> in mm	Test specimens
Pure aluminium and aluminium with up to 1,5 % impurities or alloy content	$se \leq 12$	1 BF, 1 BR, 1 T, 1 Ma
	$12 < se \leq 35$	2 BS, 1 T, 1 Ma

12.3 Non-destructive testing

12.3.1 General

Non-destructive testing personnel shall be qualified for the duties in accordance with ISO 9712.

Non-destructive testing shall be performed according to ISO 17635, ISO 5817 and ISO 10042, specifying general rules and standards to be applied to the different types of testing, for either the methodology or the acceptance level for metallic materials.

Non-destructive testing for volumetric imperfections is not required on the outer jacket of transportable cryogenic vessels.

12.3.2 Extent of examination for surface imperfections

All welds shall be visually examined in accordance with ISO 17637 and ISO 5817 or ISO 10042. If any doubt arises, this examination shall be supplemented by surface-crack detection, e.g. penetrant testing

according to ISO 3452-1 and ISO 23277. Areas from which temporary attachments have been removed shall be ground smooth and subjected to surface crack detection.

12.3.3 Extent of examination for inner-vessel weld seams

Examination of the inner vessel for inner-vessel weld seams shall be carried out by radiographic examination in accordance with ISO 17636-1 and ISO 10675-1 or ISO 10675-2.

A special case is made:

- to use radiographic techniques with digital detectors and processing according to ISO 17636-2;
- to justify ultrasonic testing in accordance with ISO 17640 and ISO 11666 (and ISO 22852 for austenitic steels), or other methods.

The extent of radiographic examination of main seams on the inner vessel shall be in accordance with [Table 9](#). See [12.3.4](#) for acceptance criteria.

When hemispherical ends without a straight flange are welded together or to a cylinder, the weld shall be tested as a longitudinal weld. Any welds within a hemispherical end shall also be tested as longitudinal welds.

Table 9 — Extent of radiographic examination for welded seams of the inner vessel

Longitudinal seams	T junctions ^a	Circumferential seams ^a
100 %	100 %	100 %
^a Unless the following conditions are met, in which case no radiographic examination is required, but a weld joint factor of 0,7 shall be used for the circumferential seam: <ol style="list-style-type: none"> 1) Circumferential seam is not a butt joint. 2) Length of the vessel is less than 1 500 mm. 3) Design pressure of the vessel is less than 2 bar (0,2 MPa). 4) The vessel is not to carry flammable or toxic fluids. NOTE 1 For additional requirements for 9 % Ni steel, see Annex B . NOTE 2 Additional examination can be required when pneumatic proof testing is used.		

12.3.4 Acceptance criteria for surface and volumetric imperfections as classified in ISO 6520-1

12.3.4.1 Acceptance levels for predominantly static loaded vessels

The results of the weld checks and inspections shall meet quality level C of ISO 5817 or ISO 10042 and the corresponding ISO standards for testing classes and acceptance levels, as defined in ISO 17635:2016, Annex A.

NDT method	Testing techniques and levels in accordance with	Acceptance levels in accordance with
Visual testing (VT)	ISO 17637	ISO 5817 Level C (for steel welds) ISO 10042 Level C (for aluminium welds)
Radiographic testing (RT)	ISO 17636-1 class B ^a	ISO 10675-1 Level 2 (for steel welds) ISO 10675-2 Level 2 (for aluminium welds)
Penetrant testing (PT)	ISO 3452-1	ISO 23277 Level 2X
^a The minimum number of exposures for circumferential weld testing may correspond to the requirements of ISO 17636-1, class A.		

Additional requirements for the following imperfections:

- stray arc (601) – removal plus 100 % penetrant testing to ensure no imperfection;
- spatter (602) – weld spatter shall be removed from all pressure parts and load carrying attachment welds;
- torn surface (603), grinding mark (604), chipping mark (605) shall be ground to provide a smooth transition;
- underflushing (606) shall not be permitted. Any local underflushing shall be related to design characteristics.

12.3.4.2 Acceptance criteria for fatigue loaded vessels

The results of the weld checks and inspections shall meet quality level B of ISO 5817 or ISO 10042 and the corresponding ISO standards for testing classes and acceptance levels as defined in ISO 17635:2016, Annex A.

NDT method	Testing techniques and levels in accordance with	Acceptance levels in accordance with
Visual testing (VT)	ISO 17637	ISO 5817 Level B (for steel welds) ISO 10042 Level B (for aluminium welds)
Radiographic testing (RT)	ISO 17636-1 class B ^a	ISO 10675-1 Level 1 (for steel welds) ISO 10675-2 Level 1 (for aluminium welds)
Penetrant testing (PT)	ISO 3452-1	ISO 23277 Level 2X
^a The minimum number of exposures for circumferential weld testing may correspond to the requirements of ISO 17636-1, class A.		

Additional requirements for the following imperfections:

- stray arc (601) – removal plus 100 % penetrant testing to ensure no imperfection;
- spatter (602) – weld spatter shall be removed from all pressure parts and load carrying attachment welds.
- torn surface (603), grinding mark (604), chipping mark (605) shall be ground to provide a smooth transition;
- underflushing (606) shall not be permitted. Any local underflushing shall be related to design characteristics.

12.3.4.3 Extent of examination of non-welded joints

Where non-welded joints are used between metallic materials and/or non-metallic materials, the quality plan referred to in 12.1 shall include reference to an adequate specification. This technical specification shall include the description of the requirements for inspection and testing, together with the criteria necessary to allow for the repair of any imperfections.

12.4 Rectification

The weld or surface imperfections may be repaired by removing the imperfections and/or rewelding, 100 % of all repaired welds shall be examined and tested to the original acceptance standards.

12.5 Pressure testing

12.5.1 Every inner vessel shall be subjected to a pressure test and its leak tightness shall be demonstrated. This leak tightness may be demonstrated during the establishment of the vacuum or by a separate leak test at pressures up to the design pressure **but not less than 90 % of the maximum allowable working pressure**.

The test pressure for the inner vessel shall not be less than the highest of:

- $1,3 (p_S + 1)$ bar [$1,3 (p_S + 0,1)$ MPa] if not surrounded by vacuum; and
- $1,3 (p_S + 1) - 1$ bar [$1,3 (p_S + 0,1) - 0,1$ MPa] if surrounded by vacuum;

considered for each element of the vessel, e.g. shell courses, head, etc.

Where the test is carried out hydraulically, the pressure shall be raised gradually to the test pressure holding it there for 30 min. Then the pressure shall be reduced to the design pressure so that a visual examination of all surfaces and joints can be made. The vessel shall show no gross plastic deformation or leakage (except as in [Annex D](#)). The test may be carried out pneumatically on a similar basis. As pneumatic testing employs substantially greater stored energy than hydraulic testing, it shall normally only be carried out where adequate facilities and procedures are employed to assure the safety of inspectors, employees and the public.

12.5.2 Vessels which have been repaired subsequent to the pressure test shall be re-subjected to the specified pressure test after completion of the repairs.

Cosmetic grinding on the base material which does not affect the required minimum thickness may be done after pressure test without doing another pressure test.

12.5.3 Where austenitic stainless steel comes into contact with water, the chloride content of the water and time of exposure shall be controlled so as to avoid stress corrosion cracking.

12.5.4 The piping system shall be subjected to a pressure test at a pressure in accordance with [10.2.3.11](#). It is not necessary to strength test mechanical joints and fittings that have demonstrated satisfactory in-service experience.

12.5.5 Leakproofness tests (see [12.1.2](#)).

13 Marking and labelling

The large transportable cryogenic vessel shall bear the required markings and labellings. Examples of tank plates (of the complete tank and of the inner vessel) for fixed tanks (tank vehicles), demountable tanks, tank containers and tank swap bodies are given for information in [Annex A](#).

At a minimum, the labelling shall include the size limitations, if any, for operation and transportation mode.

Marking shall be on a corrosion-resistant metal plate, permanently attached to the outer jacket of the cryogenic vessel, in a conspicuous place quickly accessible for inspection.

14 Final acceptance test

The first date and stamp of the expert (marks 14, 16 — see [A.1](#)) after the final acceptance test on the large transportable cryogenic vessel confirms that the marking and labelling, and that the vessel itself, meets the requirements of this document. These marks also confirm that the large transportable cryogenic vessel is ready for putting into service provided that the requirements of ISO 20421-2 are met.

15 Periodic inspection

The large transportable cryogenic vessel shall be inspected periodically with the applicable standard. By affixing the mark of the inspector and the date on the data plate, the inspector confirms the successfully completed periodic inspection.

The periodic inspection shall be done in accordance with ISO 20421-2.

16 Documentation

Technical documents delivered by the manufacturer to the owner consisting of:

- all documentation establishing the conformity with this document (e.g. material, pressure test, cleanliness, safety devices);
- a short description of the vessel (including characteristic data, etc.);
- a list of fluids and their net mass for which the cryogenic vessel is designed;
- an operating manual (for the user) which consists of:
 - a short description of the vessel (including characteristic data, etc.);
 - a statement that the vessel is in conformance with this document;
 - the instructions for normal operation.

Annex A (informative)

Examples of tank plates

A.1 Example 1: Tank plate (of the complete tank) for fixed tanks of road tankers (tank vehicles), demountable tanks, tank containers and tank swap bodies

1	Manufacturer			
2	Approval number			
3	Manufacturer's serial number	2a	Conformity mark	
4	Year of manufacture			
5	Tank code	6	Test pressure	Bar (or MPa)
7	Capacity of the tank	8	Design temperature	°C
9	Material and materials standards of	inner vessel:		
		outer jacket:		
10	Insulation	vacuum-insulated or thermally insulated by vacuum		
11	Maximum allowable working pressure	Bar (or MPa)		
12	The proper shipping name of the gas(es), for whose transport in the portable tank is approved			
13	Minimum filling temperature for each gas	°C	°C	°C
14	Maximum permissible load mass for each gas	kg	kg	kg
15	Date (month and year) of initial test and most recent periodic test			
16	Stamp of the expert who carried out the tests			
17	Name of owner or operator			
18	Maximum permissible mass	kg		
19	Unladen mass	kg		

Figure A.1 — Tank plate for the complete tank

The markings of [Figure A.1](#) are explained in [Table A.1](#).

Table A.1 — Explanation of the marking of the tank plate (complete tank)

No.	Content/explanation
1	Manufacturer's name or mark of the complete tank.
2	Approval number given by the competent authority or body designated by this authority.
2a	Conformity mark (e.g. π) according to applicable code, accompanied by the identification number of the notified or approved body.

Table A.1 (continued)

No.	Content/explanation
3	Serial or production number issued by the manufacturer.
4	Year of manufacture.
5	Tank code according to the certificate.
6	Test pressure (gauge) of the shell, in MPa or bar.
7	Water capacity, in litres.
8	Design temperature, in °C.
9	Materials of the shell (and of the ends if different) of the inner vessel and reference to materials standards, if available and materials of the shell (and of the ends if different) of the outer jacket and reference to materials standards, if available.
10	Type of insulation of the tank in words, e.g. "thermally insulated" or "thermally insulated by vacuum", if applicable, in an official language of the country of registration and also, if that language is not English, French or German, in English, French or German, unless any agreements concluded between the countries concerned in the transport operation provide otherwise.
11	Maximum (allowable) working pressure (gauge), in bar or MPa.
12	The name(s) in full of the gas(es), and, in addition for gases classified under an n.o.s. entry, the technical name of the gases, for which the tank is approved,
13	Minimum filling temperature for each gas.
14	Maximum allowable (net) mass of each gas according to mark 12, in kg.
15	Month and year of the initial inspection and of each subsequent periodic inspection.
16	Stamp of the inspector (notified or approved body) who carried out the inspection(s) of mark 14 accompanied by the identification number of the notified or approved body.
17	Name of owner or operator.
18	Maximum permissible mass (gross mass of the road tanker (tank vehicle), demountable tank, tank container and tank swap body).
19	Unladen mass (tare mass of the road tanker (tank vehicle), demountable tank, tank container and tank swap body).

A.2 Example 2 :Tank plate for the inner vessel of fixed tanks of road tankers (tank vehicles), demountable tanks, tank containers and tank swap bodies

Table A.2 — Explanation of the marking of the tank plate for the inner vessel

No.	Content/explanation
1	Manufacturer's name or mark of the inner vessel.
2	Approval number given by the competent authority or body designated by this authority
3	Serial or production number issued by the manufacturer.
4	Year of manufacture.
5	To be dropped.
6	Test pressure (gauge) of the inner vessel, in MPa or bar.
7	Water capacity, in litres.
8	Design temperature, in °C.
9	Materials of the shell (and of the ends if different) of the inner vessel and reference to materials standards, if available.
10	To be dropped.
11	Maximum (allowable) working pressure (gauge), in bar or MPa.

Table A.2 (continued)

No.	Content/explanation
12	
13	To be dropped.
14	
15	Month and year of the pressure test of the inner vessel
16	Stamp of the inspector who witnessed the pressure test
17	
18	To be dropped.
19	

Annex B (informative)

Elastic stress analysis

B.1 General

This annex provides rules to be followed if an elastic stress analysis is used to evaluate components of a large vacuum-insulated transportable cryogenic vessel for operating conditions. The loads to be considered are those defined in [10.2.3](#).

[B.4](#) and [B.5](#) give alternative criteria for demonstrating the acceptability of design on the basis of elastic analysis. The criteria in [B.5](#) apply only to local stresses in the vicinity of attachments, supports, nozzles, etc.

The calculated stresses in the area under consideration are grouped into the following stress categories:

- general primary membrane stress;
- local primary membrane stress;
- primary bending stress;
- secondary stress.

Stress intensities f_m , f_L , f_b and f_g can be determined from the principal stresses f_1 , f_2 and f_3 in each category, using the maximum shear stress theory of failure (see [B.2.1](#)).

The stress intensities determined in this way shall be less than the allowable values given in [B.3](#), [B.4](#) or [B.5](#).

If [Annex D](#) is applied, see [D.4.1.6](#), to consider the different orientation of material hardening

[Figure B.1](#) and [Table B.1](#) have been included as guidance, where [B.4](#) is used for evaluation, in establishing stress categories for some typical cases and stress intensity limits for combinations of stress categories. There will be instances when references to definitions of stresses will be necessary to classify a specific stress condition to a stress category. [B.4.5](#) explains the reason for separating them into two categories, “general” and “secondary” in the case of thermal stresses.

B.2 Terminology

B.2.1 Stress intensity

The stress intensity is twice the maximum shear stress, i.e. the difference between the algebraically largest principal stress and the algebraically smallest principal stress at a given point. Tension stresses are considered positive and compression stresses are considered negative.

The principal stresses f_1 and f_2 acting tangentially to the surface at the point under consideration should be calculated from [Formulae \(B.1\)](#) and [\(B.2\)](#):

$$f_1 = 0,5 \times \left(\sigma_1 + \sigma_2 + \sqrt{(\sigma_1 - \sigma_2)^2 + 4 \times \tau^2} \right) \quad (\text{B.1})$$

$$f_2 = 0,5 \times \left(\sigma_1 + \sigma_2 - \sqrt{(\sigma_1 - \sigma_2)^2 + 4 \times \tau^2} \right) \quad (\text{B.2})$$

where

- σ_1 is the circumferential stress;
- σ_2 is the meridional stress (longitudinal in a cylindrical shell);
- τ is the shear stress.

B.2.2 Gross structural discontinuity

A gross structural discontinuity is a source of stress or strain intensification that affects a relatively large portion of a structure and has a significant effect on the overall stress or strain pattern or on the structure as a whole.

Examples of gross structural discontinuities are:

- EXAMPLE 1 End to shell junctions.
- EXAMPLE 2 Junctions between shells of different diameters or thicknesses.
- EXAMPLE 3 Nozzles.

B.2.3 Local structural discontinuity

A local structural discontinuity is a source of stress or strain intensification that affects a relatively small volume of material and does not have a significant effect on the overall stress or strain pattern or on the structure as a whole.

- EXAMPLE 1 Small fillet radii.
- EXAMPLE 2 Small attachments.
- EXAMPLE 3 Partial penetration welds.

B.2.4 Normal stress

The normal stress is the component of stress normal to the plane of reference; this is also referred to as direct stress.

Usually the distribution of normal stress is not uniform through the thickness of a part, so this stress is considered to be made up in turn of two components, one of which is uniformly distributed and equal to the average value of stress across the thickness of the section under consideration, and the other of which varies with the location across the thickness.

B.2.5 Shear stress

The shear stress is the component of stress acting in the plane of reference.

B.2.6 Membrane stress

The membrane stress is the component of stress that is uniformly distributed and equal to the average value of stress across the thickness of the section under consideration.

B.2.7 Primary stress

A primary stress is a stress produced by mechanical loadings only and so distributed in the structure that no redistribution of load occurs as a result of yielding. A normal stress, or a shear stress developed by the imposed loading, is necessary to satisfy the simple laws of equilibrium of external and internal

forces and moments. The basic characteristic of this stress is that it is not self-limiting. Primary stresses that considerably exceed the yield strength will result in failure, or at least in gross distortion. A thermal stress is not classified as a primary stress. Primary stress is divided into “general” and “local” categories. The local primary stress is defined in [B.2.8](#).

Examples of general primary stress are:

EXAMPLE 1 The stress in a cylindrical or a spherical shell due to internal pressure or to distributed live loads.

EXAMPLE 2 The bending stress in the central portion of a flat head due to pressure.

B.2.8 Primary local membrane stress

Cases arise in which a membrane stress produced by pressure or other mechanical loading and associated with a primary and/or a discontinuity effect produces excessive distortion in the transfer of load to other portions of the structure.

Conservatism requires that such a stress be classified as a primary local membrane stress even though it has some characteristics of a secondary stress. A stressed region may be considered as local if the distance over which the stress intensity exceeds 110 % of the allowable general primary membrane stress does not extend in the meridional direction more than $0,5\sqrt{Rs}$ and if it is not closer in the meridional direction than $2,5\sqrt{Rs}$ to another region where the limits of general primary membrane stress are exceeded, where R and s are respectively the radius and thickness of the component.

An example of a primary local stress is the membrane stress in a shell produced by external load and moment at a permanent support or at a nozzle connection.

B.2.9 Secondary stress

A secondary stress is a normal stress or a shear stress developed by the constraint of adjacent parts or by self-constraint of a structure. The basic characteristic of a secondary stress is that it is self-limiting. Local yielding and minor distortions can satisfy the conditions that cause the stress to occur and failure from one application of the stress is not to be expected.

An example of secondary stress is the bending stress at a gross structural discontinuity.

B.2.9.1 Peak stress

The basic characteristic of a peak stress is that it does not cause any noticeable distortion and is objectionable only as a possible source of a fatigue crack. A stress that is not highly localized falls into this category if it is of a type that cannot cause noticeable distortion.

EXAMPLE 1 The surface stresses in the wall of a vessel or pipe produced by thermal shock.

EXAMPLE 2 The stress at a local structural discontinuity.

B.3 Limit for longitudinal compressive general membrane stress

The longitudinal compressive stress shall not exceed $0,93\Delta K$ for ferritic steels and $0,73 \Delta K$ for austenitic stainless steel and aluminium alloys, where Δ is obtained from [Figure B.2](#) or [B.3](#) in terms of P_e/P_{ySS} and where:

$$P_e = \frac{1,21Es^2}{R^2};$$

$$P_{ySS} = \frac{1,86Ks}{R} \text{ for ferritic steel; and}$$

$$P_{y_{ss}} = \frac{1,46Ks}{R} \text{ for austenitic stainless steel and aluminium alloys.}$$

B.4 Stress categories and stress limits for general application

B.4.1 General

A calculated stress depending upon the type of loading and/or the distribution of such stress will fall within one of the five basic stress categories defined in [B.4.2](#) to [B.4.6](#). For each category, a stress intensity value is derived for a specific condition of design. To satisfy the analysis, this stress intensity shall fall within the limit detailed for each category.

B.4.2 General primary membrane stress category

The stresses falling within the general primary membrane stress category are those defined as general primary stresses in [B.2.7](#), and are produced by pressure and other mechanical loads, but excluding all secondary and peak stresses. The value of the membrane stress intensity is obtained by averaging these stresses across the thickness of the section under consideration. The limiting value of this stress intensity f_m is the allowable stress value $2K/3$.

B.4.3 Local primary membrane stress category

The stresses falling within the local primary membrane stress category are those defined in [B.2.8](#) and are produced by pressure and other mechanical loads, but excluding all thermal and peak stresses. The stress intensity f_L is the average value of these stresses across the thickness of the section under consideration and is limited to K .

B.4.4 General or local primary membrane plus primary bending stress category

The stresses falling within the general or local primary membrane plus primary bending stress category are those defined in [B.2.7](#), but the stress intensity value f_b , $(f_m + f_b)$ or $(f_L + f_b)$ is the highest value of those stresses acting across the section under consideration, excluding secondary and peak stresses. f_b is the primary bending stress intensity, which means the component of primary stress proportional to the distance from centroid of solid section. The stress intensity f_b , $(f_m + f_b)$ or $(f_L + f_b)$ is not to exceed K .

B.4.5 Primary plus secondary stress category

The stresses falling within the primary plus secondary stress category are those defined in [B.2.7](#) plus those of [B.2.9](#) produced by pressure, other mechanical loads and general thermal effects. The effects of gross structural discontinuities, but not of local structural discontinuities (stress concentrations), should be included. The stress intensity value $(f_m + f_b + f_g)$ or $(f_L + f_b + f_g)$ is the highest value of these stresses acting across the section under consideration and shall be limited to $2K$.

B.4.6 Thermal stress

Thermal stress is a self-balancing stress produced by a non-uniform distribution of temperature or by differing thermal coefficients of expansion. Thermal stress is developed in a solid body whenever a volume of material is prevented from assuming the size and shape that it normally should under a change in temperature.

For the purpose of establishing allowable stresses, the following two types of thermal stress are recognized, depending on the volume or area in which distortion takes place:

- a) general thermal stress is associated with distortion of the structure in which it occurs. If a stress of this type, neglecting stress concentrations, exceeds $2K$, the elastic analysis may be invalid and

successive thermal cycles may produce incremental distortion. This type is therefore classified as secondary stress in [Table B.1](#) and [Figure B.1](#).

Examples of general thermal stress are:

EXAMPLE 1 The stress produced by an axial thermal gradient in a cylindrical shell.

EXAMPLE 2 The stress produced by the temperature difference between a nozzle and the shell to which it is attached.

- b) Local thermal stress is associated with almost complete suppression of the differential expansion and thus produces no significant distortion. Such stresses are only considered from the fatigue standpoint.

EXAMPLE A small cold spot in a vessel wall.

B.5 Specific criteria, stress categories and stress limits for limited application

B.5.1 General

The criteria and stress limits for particular stress categories for elastically calculated stresses adjacent to attachments and supports and to nozzles and openings which are subject to the combined effects of pressure and externally applied loads are specified in [B.5.2](#) to [B.5.4](#).

The minimum separation between adjacent loaded attachments, pads, nozzles or openings or other stress concentrating features shall not be less than $2,5\sqrt{Rs}$.

R and s are respectively the radius and thickness of the component. The criteria of [B.2.8](#) are not applicable to this section.

If design acceptability is demonstrated by [B.5](#), then the use of [B.4](#) is not required.

B.5.2 Attachments and supports

The dimension in the circumferential direction of the loaded area shall not exceed one-third of the shell circumference. The stresses adjacent to the loaded area due to pressure acting in the shell may be taken as the shell pressure stresses without any concentrating effects due to the attachment.

Under the design combined load, the following stress limits apply:

- the primary membrane stress intensity should not exceed $0,6K$ or $0,3R_m$;
- the stress intensity due to the sum of primary membrane and primary bending stresses shall not exceed $4K/3$;
- the stress intensity due to the sum of primary membrane stresses, primary bending stresses and thermal stresses shall not exceed $2K$.

B.5.3 Nozzles and openings

The nozzle or opening shall be reinforced in accordance with [10.3.6.7](#).

Under the design combined load, the following stress limits apply:

- the primary membrane stress intensity should not exceed $0,8K$;
- the stress intensity due to the sum of primary membrane stresses and primary bending stresses shall not exceed $1,5K$;
- the stress intensity due to the sum of primary membrane stresses, primary bending stresses and thermal stresses shall not exceed $2K$.

B.5.4 Additional stress limits

Where significant compressive membrane stresses are present, the possibility of buckling shall be investigated and the design modified if necessary (see B.3). In cases where the external load is highly concentrated, an acceptable procedure would be to limit the sum of membrane and bending stresses (total compressive stress) in any direction at the point to $0,9K$.

Where shear stress is present alone, it shall not exceed $K/3$. The maximum permissible bearing stresses should not exceed K .

Table B.1 — Classification of stresses for some typical cases

Vessel component	Location	Origin of stress	Type of stress	Classification	
Cylindrical or spherical shell	Shell plate remote from discontinuities	Internal pressure	General membrane	f_m	
			Gradient through plate thickness	f_g	
		Axial thermal gradient	Membrane	f_g	
	Junction with head	Internal pressure	Bending	f_g	
			Membrane	f_L	
Any shell or end	Any section across entire vessel	External load or moment, or internal pressure	Membrane	f_m	
			Bending across full section, stress component perpendicular to cross-section	f_m	
	Near nozzle or other opening	External load or moment, or internal pressure	Local membrane	f_L	
			Bending	f_g	
	Any location	Temperature difference between shell and end	Membrane	f_g	
			Bending	f_g	
	Dished end or conical end	Crown	Internal pressure	Membrane	f_m
				Bending	f_b
Knuckle or junction to shell		Internal pressure	Membrane	f_L	
			Bending	f_g	
Flat end	Centre region	Internal pressure	Membrane	f_m	
			Bending	f_b	
	Junction to shell	Internal pressure	Membrane	f_L	
			Bending	f_g	
Perforated end or shell	Typical ligament in a uniform pattern	Pressure	Membrane (average through cross section)	f_m	
			Bending (average through width of ligament, but gradient through plate)	f_b	
	Isolated or atypical ligament	Pressure	Membrane	f_g	
			Bending	f_g	
Consideration should also be given to the possibility of buckling and excessive deformation in vessels with large diameter-to-thickness ratio.					

Table B.1 (continued)

Vessel component	Location	Origin of stress	Type of stress	Classification
Nozzle	Cross section perpendicular to nozzle axis	Internal pressure or external load or moment	General membrane (average across full section), stress component perpendicular to section)	f_m
			Bending across nozzle section	f_m
	Nozzle wall	Internal pressure	General membrane	f_m
			Local membrane	f_L
			Bending	f_g
		Differential expansion	Membrane	f_g
Bending	f_g			

Consideration should also be given to the possibility of buckling and excessive deformation in vessels with large diameter-to-thickness ratio.

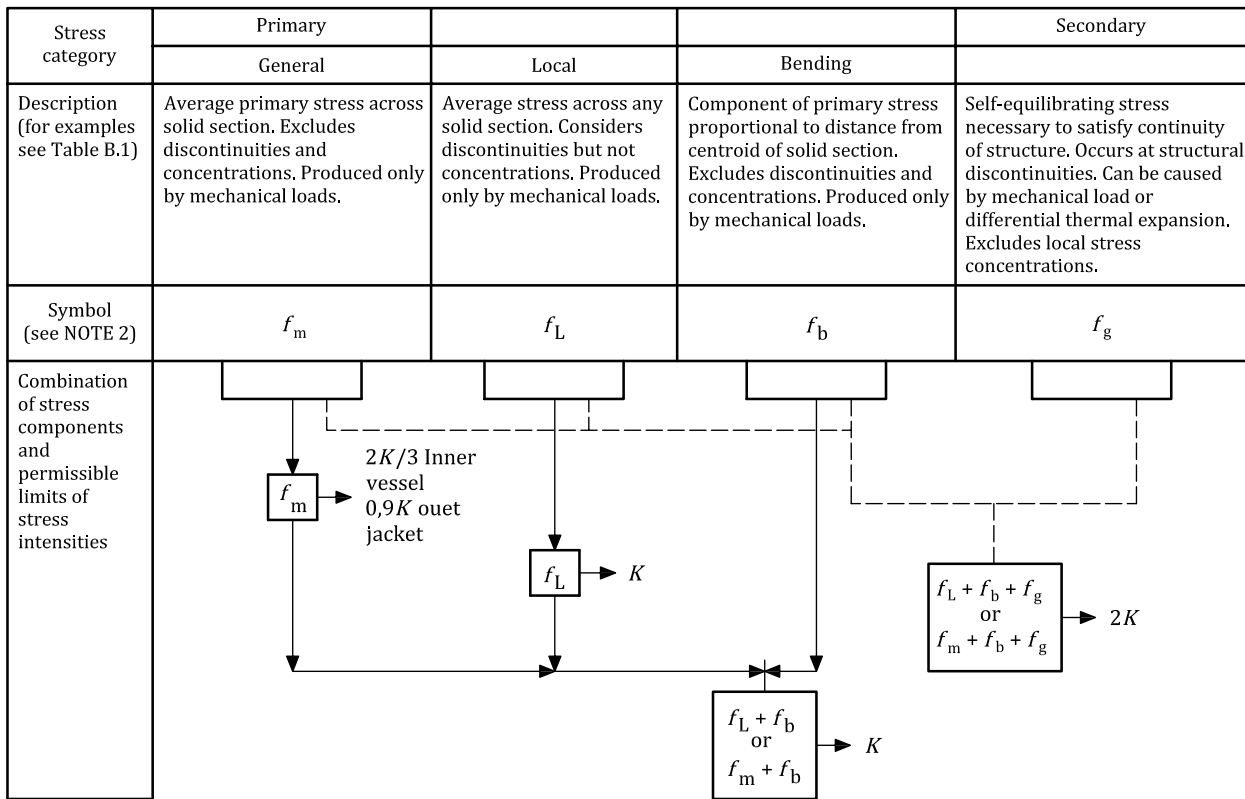

NOTE The symbols f_m , f_L , f_b and f_g do not represent single quantities but rather sets of six quantities representing the six stress components.

Figure B.1 — Stress categories and limits of stress intensity

The stresses in category f_g are those parts of the total stress which are produced by thermal gradients, structural discontinuities, etc., and do not include primary stresses which can also exist at the same point. It should be noted, however, that a detailed stress analysis frequently gives the combination of primary and secondary stresses directly and, when appropriate, this calculated value represents the total of f_m (or f_L) + f_b + f_g and not f_g alone.

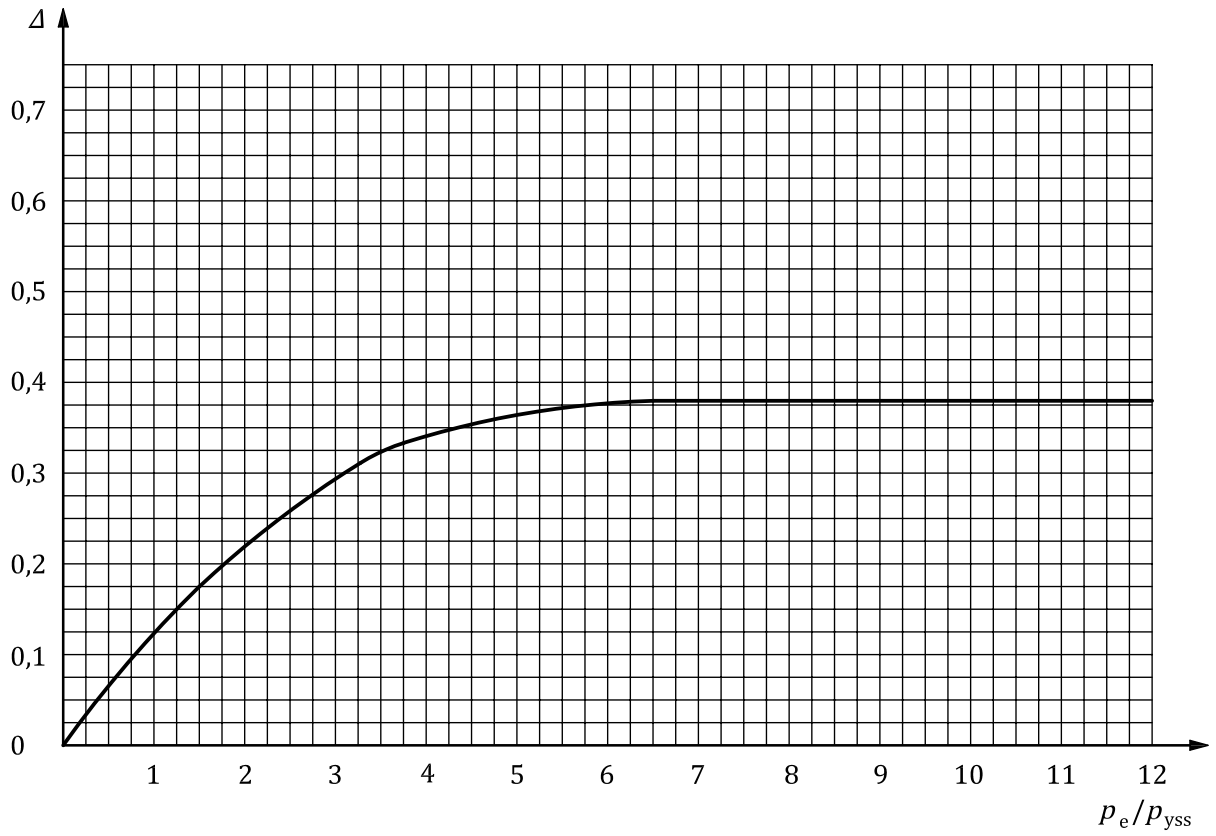

Figure B.2 — For vessels subject to external pressure

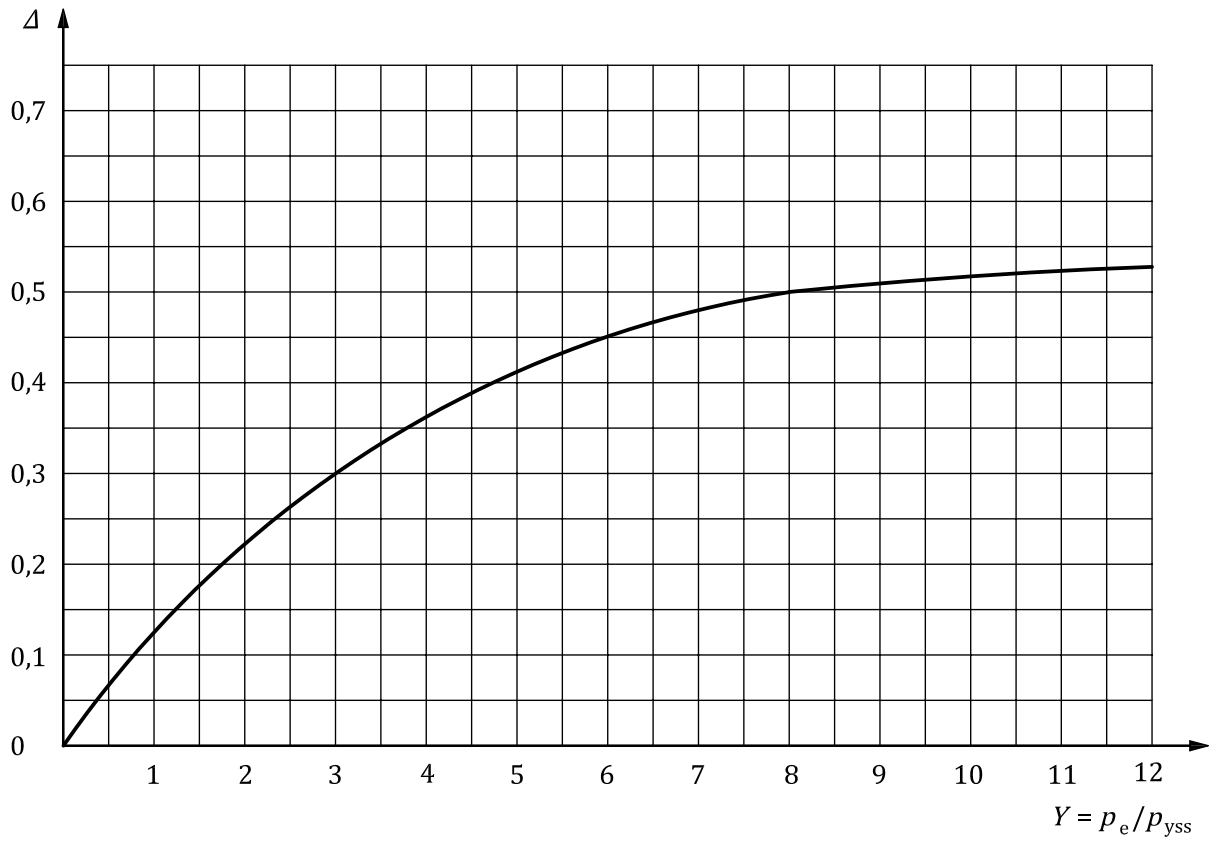

Figure B.3 — For vessels not subject to external pressure

Annex C (normative)

Additional requirements for 9 % Ni steel

C.1 General

Vessels constructed of 9 % Ni steels are normally welded using an austenitic or modified austenitic consumable. The 1 % or 0,2 % proof strength of the parent plate material normally exceeds that of an all-weld metal sample. These weld metals exhibit excellent ductility and work-hardening characteristics. After work hardening, the enhanced proof strength of the weld metal is maintained within an entirely elastic regime.

The value of K to be adopted in the calculation formula of [Table 7](#) is that of the parent 9 % Ni steel material.

During the first proof pressure test after fabrication, the welds plastically strain by a small, but sufficient amount such that their strength increases to create equilibrium with the applied loads. Thereafter, the vessel behaves elastically when subjected to the maximum allowable working pressure.

C.2 Specific requirements

C.2.1 The minimum design temperature of vessels constructed of 9 % Ni steel shall not be less than $-196\text{ }^{\circ}\text{C}$.

C.2.2 The maximum design temperature shall not exceed $50\text{ }^{\circ}\text{C}$, when defrosting or drying the vessel at low pressure.

C.2.3 The maximum thickness of the vessel at the weld edge preparation shall not exceed 30 mm. A high-nickel austenitic weld wire shall be used when the thickness of the vessel at the weld edge preparation exceeds 20 mm.

C.2.4 The full length of all branch attachment welds shall be examined by dye penetrant before the first proof pressure test.

C.2.5 Imperfections that are unacceptable according to this document shall be repaired and re-examined to demonstrate compliance.

C.2.6 The vessel and all welds shall be examined visually after the proof pressure test to ensure that there is no evidence of gross deformation.

C.2.7 The weld procedure qualification and production control transverse tensile test specimens shall:

- show no gross deformation when subjected to a tensile stress equal to the minimum specified material property K of the parent plate. Some small reduction in area is acceptable due to the expected plastic deformation associated with strain hardening. The measured 1 % proof stress of the transverse tensile test piece when using a 50 mm gauge length shall not be less than the minimum specified material property " K " of the parent plate;
- demonstrate a rupture strength not less than the minimum specified ultimate strength of the parent plate.

NOTE These items also apply to work-hardened austenitic stainless steel.

C.2.8 Longitudinal bend tests shall be used rather than side bend tests as permitted by ISO 15607 when qualifying weld procedures or testing production control test plates.

C.2.9 The heat-affected zone at the weld fusion boundary shall be demonstrated to attain an ISO V-notch impact strength of 50 joules or 0,38 mm for lateral expansion at $-196\text{ }^{\circ}\text{C}$, as an average of three test pieces, during weld procedure qualification and production control plate testing. These tests shall be performed in accordance with ISO 21028-1 and ISO 21028-2.

C.2.10 Openings shall not be located with their centre lines closer to principal seams than twice their diameter.

NOTE These items also apply to work-hardened austenitic stainless steel.

C.2.11 Butt welds shall not be located where they are subject to high bending stresses which can result in plastic cycling and incremental collapse.

C.2.12 9 % Ni vessels may be fitted with nozzles of stainless steel. Where the outside diameter of the nozzle exceeds 75 mm, the stresses in the shell and nozzle, due to pressure, mechanical loads and thermal expansion, shall be assessed and shown to comply with the requirements of [Annex A](#) and to provide an adequate fatigue life for the intended application of the vessel.

C.2.13 Filler wires shall be selected from austenitic, modified austenitic or high-nickel austenitic materials.

C.2.14 9 % Ni material conforming to ISO 9328-4 is suitable for the construction of cryogenic vessels conforming to this document. Other materials may be suitable provided sufficient test data is made available to demonstrate the suitability of the material.

Annex D (normative)

Pressure strengthening of vessels from austenitic stainless steels

D.1 General

Austenitic stainless steel exhibits stress/strain characteristics [Figure D.1 b)], different from that of carbon steel (Figure D.1), that enable stainless steel to accept strain as a means of increasing its proof strength. Plastic deformation of 10 % is possible with steels having an elongation at fracture of at least 35 % in the solution heat-treated condition.

Austenitic stainless steel that has been strained to a higher proof strength will retain and even increase its enhanced strength advantage at cryogenic temperatures.

For instance, when austenitic stainless steel is loaded in tension to a stress σ_k above its proof strength and then unloaded, a permanent plastic elongation will result. When this steel is loaded again, it will remain elastic up to this higher stress which is then the new proof strength; only when the stress exceeds σ_k will the deformation be plastic, and it will then follow the original stress/strain curve.

When the strengthening stress σ_k has been chosen, the minimum wall thickness of parts of the vessel can be calculated from the design stress to be equal to or less than three-quarters of σ_k (which is equal to the new proof strength). In practice, the strengthening is produced by pressurizing the finished vessel to a pressure p_k known to produce the required stress, which in turn gives the required amount of plastic deformation to withstand the pressure load.

This technology primarily applies to vessels (or parts of vessels) of non-complex “balloon-type” design, i.e. structures where the pressure-induced membrane stresses are dominant. Other parts of the vessel are normally designed based on conventional design stress values in D.4 and the relevant annexes of this document.

NOTE This method is also known as “cold-stretching”. However, using the word “cold” in connection with cryogenic vessels can be misleading since the strengthening pressure is applied at room temperature. Also, the “stretching” is slight if any when using shell material in the work-hardened condition. On the other hand, applying a pressure in excess of the normal test pressure effectively demonstrates the strength and pressure-bearing capability of all parts of the complete vessel.

D.2 Application of this annex

This annex applies to cryogenic pressure vessels made from austenitic stainless steel of a wall thickness of not more than 30 mm, strengthened by pressurization at room temperature after being completed and intended for a maximum operating temperature of less than 50 °C.

D.3 Materials

D.3.1 Accepted materials of construction that have already been proven suitable for pressure strengthening for operating temperatures of not less than -196 °C are the austenitic stainless steels specified in Table D.1. Requirements regarding these materials are found in ISO 9328-7.

When material is delivered in a work-hardened condition, the material shall have an elongation at fracture A_5 of not less than 35 %.

Table D.1 — Austenitic stainless steels accepted for pressure strengthening of cryogenic vessels for operating temperatures of not less than $-196\text{ }^{\circ}\text{C}$

Steel designation		Solution heat-treated material		Pressure-strengthened vessel
Name	Number	$R_{p0,2}$ N/mm ² min.	$R_{p1,0}$ N/mm ² min.	σ_k N/mm ² max.
X5CrNi18-10	1.4301	210	250	410
X2CrNi19-11	1.4306	200	240	400
X2CrNi18-10	1.4311	270	310	470
X6CrNiTi18-10	1.4541	200	240	400
X6CrNiNb18-10	1.4550	200	240	400
X5CrNi19-09	1.4315	270	310	470
SA/A-240 340	S 30400	—	—	410
SA/A-240 304L	S 30403	—	—	385
SA/A-240 304N	S 30451	—	—	470
SA/A-240 316	S 31600	—	—	410
SA/A-240 316L	S 31603	—	—	385
SA/A-240 316N	S 31651	—	—	470
SA/A-240 316LN	S 31653	—	—	410

D.3.2 In case stable or metastable austenitic steels (when the strengthening strain exceeds 5 %) according to [Clause 9](#), other than those listed in [Table D.1](#), are to be qualified for pressure strengthening, or the vessel operating temperature will be below $-196\text{ }^{\circ}\text{C}$, steel quality and welding procedure shall be validated by the type approval test detailed below. This test shall be carried out in addition to the tests required by [9.1](#) and [11.6.1](#).

A welded test plate shall be pre-stretched to an elongation of 15 % (in one direction).

From this test plate, specimens shall be tested as per [Table D.2](#).

Table D.2 — Testing of pre-stretched production test plates for steels

Group	Test specimens
Austenitic stainless steels $\leq 12\text{ mm}$	1 BF, 1 BR, 1 TT, 1TW, 1 Ma
Austenitic stainless steels $> 12\text{ mm}$	1 BF, 1 BR, 1 TT, 1TW, 1 Ma, 3 IW

- base material: two tensile tests along the direction of the applied stress and one set of impact tests across the direction of the applied stress;
- weld: two tensile tests across the weld and one set of impact tests of the weld metal according to ISO 21028-1 and ISO 21028-2.

One tensile test and the impact tests shall be carried out at the lowest operating temperature. The other tensile test shall be carried out at $20\text{ }^{\circ}\text{C}$. The impact value shall not be less than 0,53 mm lateral expansion.

The base material and the weld shall follow [Formulae \(D.1\)](#) to (D.3):

$$R_{p0,2} \geq \sigma_k \tag{D.1}$$

$$A_5 \geq 25\% \tag{D.2}$$

$$\alpha_{k \text{ ISO-V}} \geq 48 \text{ J/cm}^2 \quad (\text{D.3})$$

D.3.3 The welded test plate shall be pre-stretched (on one direction) to an elongation of 15 % before working out the specimen for destructive testing.

D.4 Design

D.4.1 General

D.4.1.1 Wall thicknesses calculated according to [D.4.3](#) refers to thicknesses before strengthening.

D.4.1.2 Nominal diameters may be used in the design calculations. No allowance is necessary for the possible increase in diameter due to strengthening.

D.4.1.3 Maximum design stress value is limited to 200 N/mm² above $R_{p0,2}$ for the material in the solution heat-treated condition.

D.4.1.4 The weld joint factor 1,0 may be used for the calculation of all pressure strengthened parts of the vessel (longitudinal welds in cylinder, cone or end).

D.4.1.5 Pressure strengthening applies to vessels (or part of vessels) where the pressure-induced membrane stresses are dominant. Other parts of the vessel shall be designed in accordance with [Clause 10](#) and the relevant annexes of this document. This requirement shall not preclude utilization of the strengthening process, provided the manufacturer can show that it does not cause deformations that impair the integrity of the vessel.

D.4.1.6 Fastenings and supports should be preferably attached in non-cold stretched areas otherwise for the simultaneously acting pressure and additional loads the different orientation of material hardening (anisotropic hardening) has been taken into account.

D.4.2 Design for internal pressure

D.4.2.1 Design stress values

The design stress value σ_k at 20 °C can be selected freely up to the highest allowable design stress value σ_{kmax} according to [Table D.1](#). This highest allowable design stress value is the same whether the material used is in the solution heat-treated or work-hardened condition.

D.4.2.2 Calculation of the strengthening pressure

The required strengthening pressure p_k is calculated according to [Formula \(D.4\)](#):

$$p_k \geq 1,33p_T \quad (\text{D.4})$$

NOTE Strained material is also known to increase its strength when cooled to cryogenic temperatures. However, the effect on strengthening pressure (analogous to the effect on test pressure as in [10.3.2.3.3](#)) is not taken into account in this Annex.

D.4.2.3 Calculation of wall thicknesses

D.4.2.3.1 General

The wall thickness of the various parts of the pressure vessel shall be calculated according to applicable subclauses of this document with the modifications shown in [Table D.3](#).

Table D.3 — Modification of formula for the design of pressure-strengthened vessels

Subclause		Modification, see subclause in this annex
10.3.6.1	Cylinders and spheres subject to internal pressure	D.4.2.3.3
10.3.6.4	Dished ends subject to internal or external pressure, 10.3.6.4.3 — Internal pressure calculation (pressure on the concave surface)	D.4.2.3.4
10.3.6.5.5/ 10.3.6.5.6	Cones subject to internal or external pressure 10.3.6.5.5 — Internal-pressure calculation (pressure on the concave surface) $ \varphi \leq 70^\circ$, 10.3.6.5.6 — Internal-pressure calculation (pressure on the concave surface) $ \varphi > 70^\circ$	D.4.2.3.4 D.4.2.3.2
10.3.6.6	Flat ends	D.4.2.3.2
10.3.6.7	Openings in cylinders, spheres and cones	D.4.2.3.2 D.4.2.3.5

D.4.2.3.2 Parts where bending stresses are dominant and large deformations cannot be accepted, like flat cones according to [10.3.6.5.6](#) and flat ends according to [10.3.6.6](#), shall be calculated in the normal way using the design pressure p and design stress values according to [10.3.2.3](#). That is, the effect of the strengthening may not be used in such designs.

Additionally, the capability to pass the strengthening without plastic deformation shall be checked by repeating the calculations using the strengthening pressure (taking the mass of contents into account) for the test pressure p_T and the design stress value at 20 °C from [10.3.2.3](#).

D.4.2.3.3 When designing parts according to [10.3.6.1](#), insert into the applicable formula the following:

- design stress value σ_k ;
- weld joint factor 1,0.

D.4.2.3.4 Parts shall be designed with the same modifications as in [D.4.2.3.3](#). Additionally the shape factor β for dished ends may be reduced to:

- for 10 % torispherical ends, 2,93;
- for 2:1 elliptical ends, 1,91.

However, it shall be demonstrated by calculation or experiment that the strain during strengthening will not cause excessive deformation in regions subject to bending stresses. In cases where the deformation will lead to a better shape (e.g. deeply dished ends turning hemispherical) the method may be used even with large bending stresses.

Also, the risk of buckling in regions where compressive stresses occur (i.e. the knuckle of dished ends and corner area of cones) shall be paid special attention. However, since buckling is heavily dependent on initial imperfections and work-hardening of the material before pressurization, there is no substitute for experience. However, the stretching process in itself will reveal any such tendencies (see [D.5.1](#)).

D.4.2.3.5 For reinforcements of openings, the stiffness of the attachment shall be considered so that over-dimensioned reinforcements are avoided. Preferably, openings without reinforcement should be used. Unreinforced openings in this context include openings having reinforcement not complying with [10.3.6.7.4](#).

For openings, where the hole diameter exceeds that given below, calculation of the reinforcement shall be made according to [10.3.6.7](#) with the same modifications as in [D.4.2.3.3](#).

When using external plate reinforcement or other kinds of reinforcements that are not welded with full penetration, the risk of overloading of the welds during strengthening shall be observed.

When ligament efficiency is less than 1, stresses due to strengthening shall be analysed according to [10.3.6.7](#).

D.4.2.3.6 Largest allowed opening of unreinforced single holes.

In the case of holes joining a nozzle, etc. to the shell, the inside diameter of the nozzle shall not exceed d_{\max} .

- d_{\max} = diameter of largest allowed opening (major axis for oval holes), in mm;
- D_y = outside diameter of shell, in mm;
- R = inside crown radius of end, in mm;
- s_0 = wall thickness of unpierced shell, in mm;
- s = true wall thickness of shell, in mm;
- $\mu = s_0/s$;
- $C = 60\sqrt{2(1-\mu)}$ with a maximum of 60 mm.

$$d_{\max} = 0,4\sqrt{D_y \times s + C} \quad (\text{D.5})$$

The value of d_{\max} calculated according to [Formula \(D.5\)](#) may be rounded up to the nearest higher even 10 mm. d_{\max} , however, shall meet the conditions in [Formulae \(D.6\)](#) and [\(D.7\)](#):

$$d_{\max} \leq 150 \text{ mm} \quad (\text{D.6})$$

$$d_{\max} \leq 0,2D_y \quad (\text{D.7})$$

The wall thickness of an unpierced cylinder is calculated from [Formula \(D.8\)](#):

$$s_0 = \frac{pD_y}{20\frac{\sigma_k}{1,33} + 2p} \quad (\text{D.8})$$

The wall thickness of the crown region of an unpierced dished end is calculated from [Formula \(D.9\)](#):

$$s_0 = \frac{pR}{20\frac{\sigma_k}{1,33}} \quad (\text{D.9})$$

D.4.3 Design for external pressure

D.4.3.1 If a pressure strengthened vessel normally operating under internal pressure can be subject to external pressure, the vessel shall also be designed to withstand external pressure according to the applicable subclauses of [Clause 10](#).

By these calculations, the design stress value shall be taken from [10.3.2.3](#). If the pressure-strengthened vessel is made from solution heat, treated material the safety factors S_k given in [10.3.2.4](#) may be replaced by $S_k/1,5$.

NOTE This modification is a consequence of the improved shape of the pressure vessel produced by the straining so that a lower factor of safety can be accepted.

In the case of vessels having large nozzles in the shell or when this improvement of the shape is otherwise doubtful, the above modification may be used only if measurements after strengthening show that the vessel is not significantly out of round.

D.4.3.2 If a vessel is shaped such that it is subject to an external pressure during the strengthening operation, it shall be calculated using the strengthening pressure (taking the mass of contents into account) as a test pressure p_T and the material properties at 20 °C from [10.3.2.3](#).

D.5 Manufacturing and inspection

D.5.1 Strengthening procedure

D.5.1.1 The strengthening operation, which is a step in the production of the finished vessel, shall be made following written procedures. These procedures shall include the steps described in [D.5.1.2](#) to [D.5.1.6](#).

The procedure shall be monitored and verified on a prototype or a demonstration vessel.

When vessels under pressure require inspection and measurement, adequate facilities and procedures shall be employed to assure the safety of inspectors, employees and the public.

D.5.1.2 The vessel is filled with liquid. Before the vessel is closed, there should be a wait of at least 15 min to let any air dissolved in the liquid escape. The vessel is then topped up and sealed.

D.5.1.3 The circumference of all courses shall be measured (e.g. with steel tapes) where the largest increase in cross-section is expected. The strain rate during the strengthening operation shall be calculated over the full circumference.

D.5.1.4 The strengthening shall be carried out as follows. The pressure is raised to the strengthening pressure and maintained until the strain rate has dropped to less than 0,1 %/h. The time under pressure shall be not less than one hour (see however [D.5.1.5](#)). The strain rate shall be checked by repeated measurements of the circumference according to [D.5.1.3](#). The requirement of 0,1 %/h shall be met during the last half hour.

NOTE The total time under pressure can be long. This can be reduced if a 5 % higher pressure is applied during the first 30 min to 1 h of the operation.

D.5.1.5 For pressure vessels having a diameter not more than 2 000 mm, the time under pressure may be reduced to 30 min and the requirement of 0,1 %/h be met during the last 15 min.

D.5.1.6 The strengthening operation replaces the initial pressure testing of the vessel. Should later pressure testing be required, only the normal test pressure shall be used. If the vessel needs to be repaired, this repair and pressure testing or possibly renewed strengthening shall be carried out in accordance with [D.5.3](#).

D.5.2 Procedure record

There shall be a written record of the operation, containing at least the following information:

- pressurizing sequence specifying pressure readings and time;
- circumference measurements before, during and after pressurization;
- strain rate calculations from circumference measurements according to [D.5.1.4](#);
- any significant changes of shape and size relevant to the functioning of the vessel;
- any requirement for renewed strengthening (according to [D.5.1.6](#) and [D.5.3](#));
- The material sheets shall be placed so that the direction of rolling is in the same direction as the vessel's circumference. The difference between the metal sheets used for the vessel shell shall not exceed the criteria of [Formula \(D.10\)](#):

$$\left(k_{p0,2(\text{certificate})} \times S_{(\text{measured value } e)}\right)_{\max} / \left(k_{p0,2(\text{certificate})} \times S_{(\text{measured value } e)}\right)_{\min} \leq 1,2 \quad (\text{D.10})$$

D.5.3 Welding

The strengthening method presumes high-quality welding. The same rules apply as for conventionally produced cryogenic vessels, except that production control test plates need not be taken.

Irregularities shall be inside of the limits according to ISO 5817 evaluation group B.

D.5.4 Pressure-vessel drawing

D.5.4.1 In addition to the information required by [10.2.2](#), the drawing shall bear the following text:

- the vessel is manufactured according to [Annex D](#);
- strengthening pressure, in bars or in MPa;
- thicknesses and diameters shown apply before strengthening.

D.5.4.2 Details to be welded in place after the strengthening shall be marked on the drawing.

D.5.5 Inspection and testing

D.5.5.1 For testing production control, on a regular basis the welded test plates shall be pre-stretched (in one direction) to an elongation of 15% before working out the specimen for destructive testing.

D.5.5.2 Non-destructive testing

D.5.5.2.1 Non-destructive testing shall be carried out before the strengthening to the extent stipulated in [12.3](#) for the weld joint factor 1,0.

Irregularities shall be inside of the limits according to ISO 5817 evaluation group B.

D.5.5.2.2 After the strengthening operation and reducing the pressure to the ambient pressure, welds shall be visually examined externally for their full lengths. Where high local stress and strain concentrations can be expected during the strengthening operation, examination with liquid penetrant shall also be carried out, e.g. at changes in wall thickness or at welded nozzles. Places which have been examined with liquid penetrant according to [D.5.5.2.1](#) shall also if possible be tested at random using a volumetric method (preferably by radiographic examination).

D.5.5.2.3 Renewed strengthening shall be carried out if pressure-strengthened parts of the vessel have been significantly affected by post-strengthening welding. Exceptions are permitted for tack-welding of attachments carrying low loads only (e.g. insulation supports) and welding of nozzles not more than 10 % of the vessel inner diameter (with a maximum of 100 mm) or minor weld repairs with comparable effect on the construction. Such welds shall be examined according to [D.5.5.2.1](#) and [D.5.5.2.2](#).

Unless renewed pressure strengthening is carried out, there shall be a normal pressure test as required by [12.5.2](#) after all welding on pressure-retaining parts.

D.5.5.2.4 Repairing pressure strengthening vessels

To ensure good repairs, these should be performed exclusively by the manufacture. Only repairs to cold stretched components are given below. In case of repair, a hydrostatic pressure test shall be carried out

at stretching pressure (p_k), and then a radiographic examination and liquid penetration test shall be performed. The repairs and the subsequent test shall be documented.

a) Repairing weld

Defective points in welds metal shall be machined. Welding qualification is required for repairing the weld. The repair weld has to be tested by means of radiographic examination and liquid penetration test. Strength shall be verified by an extended hydrostatic pressure test with a Pressure acc. to P_k (see. D).

b) Extension of radiographic examination

When defects except tolerances are revealed during the RX sounding, one or several supplementary films (200 mm mini) will be realized in the continuation of one or several defects, whether it is before hydraulic test or after hydraulic test.

See [12.4](#)

c) Installation of none-strain hardening material

In case plates are inserted in the shell of pressure vessel, as a matter of principle, the same material shall be used. The strength of these plates shall be suitable for their place of installation in the cold stretched vessels.

The welds have to be subjected to a visual examination.

D.5.6 Data plate

The data plate shall, in addition to the information in [Clause 14](#), bear the text "PRESSURE STRENGTHENED".

D.6 Comments

D.6.1 Strengthening theory

Austenitic stainless steels exhibit considerable work hardening upon deformation while retaining the characteristics of the material. The stress required for further deformation increases continuously as the deformation increases. Thus, a stress/strain curve for austenitic steel does not have the flow region typical of carbon and low-alloy steels. Compare the stress/strain curves in [Figure D.1](#) a) and b).

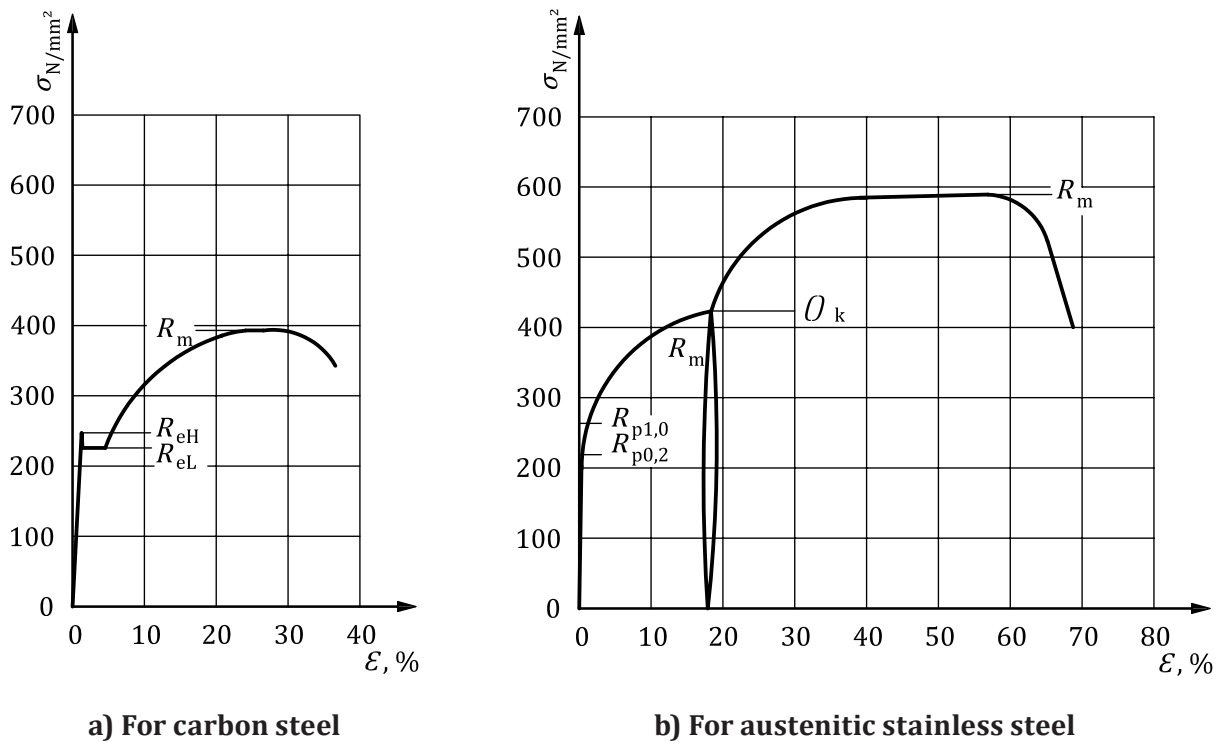

Figure D.1 — Stress/strain curve for carbon and austenitic stainless steel

If a tensile test piece of solution heat-treated austenitic stainless steel is loaded to a strengthening stress σ_k and then unloaded, a permanent plastic elongation will be found. When the same test piece is loaded again, the deformation will remain elastic up to a higher stress level than before. Only when the stress σ_k is exceeded will the plastic deformation continue along the original curve.

A test piece which has been loaded to the strengthening stress σ_k can be regarded as a new test piece with [Formula \(D.11\)](#):

$$R_{p0,2} = \sigma_k \quad (D.11)$$

An austenitic stainless steel that has been stretched at room temperature to a higher proof strength also exhibits higher proof-strength stress at all other temperatures.

The toughness of the material after stretching to 10 % (nominal strain) will still be satisfactory, since austenitic steels in the solution heat-treated condition have an elongation at fracture not less than 35 %.

The plastic deformation required is achieved by subjecting the finished pressure vessel to a strengthening pressure, p_k . This pressure is calculated so that there is sufficient safety margin with respect to plastic deformation from stresses caused by a pressure equal to the design pressure, p .

Minimum wall thicknesses for the different parts of the vessel are calculated after establishing a suitable design stress value, σ_k .

During the strengthening of the finished vessel, the material reaches a strengthening stress, σ_k , that is at least 1,33 times the design stress, p , and 1,73 times the stress at maximum allowable pressure, p_s .

D.6.2 Work-hardened material

D.6.2.1 The term “work-hardened material” shall be applied to material that has had its proof strength raised through cold rolling, roll straightening, uniaxial stretching in a stretching machine or other types of cold work.

D.6.2.2 Work-hardened material can be used in order to reduce or eliminate the deformation due to strengthening of the pressure vessel. It is primarily used in cylinders for internal pressure.

D.6.2.3 The increase in the proof strength of a work-hardened material is about the same in all directions. The proof strength of work-hardened plate shall be determined on samples taken across the direction of rolling or stretching, respectively.

D.6.2.4 The structure of work-hardened material differs from solution heat-treated material only in that the number of dislocations is higher. Material that has been subject to a homogeneous deformation is free from residual stresses. Work hardening does not significantly affect the resistance to general corrosion.

Welding of work-hardened material gives rise to a heat-affected zone (HAZ), the width of which depends on the welding method. In arc welding with coated electrodes, the width of the zone is about equal to the thickness of the material.

The proof strength in the zone may be reduced, but the subsequent strengthening restores it to about the same level as that of the surrounding material.

Impact toughness and corrosion resistance in the zone depend primarily on the initial material condition (analysis, well-annealed structure) and the welding method (extent of heating) but only slightly on the degree of strengthening.

Strengthening of a pressure vessel generally decreases local residual stresses introduced into the vessel during the manufacturing process.

D.6.3 Derivation of formula

D.6.3.1 Consider a cylinder of middle diameter D and design pressure p , which has been strengthened to a design stress value σ_k . Its wall thickness should comply with [Formula \(9\)](#), see [Formula \(D.12\)](#):

$$s = \frac{pDs_F}{20\sigma_k z} \quad (\text{D.12})$$

NOTE To simplify the formula, the middle diameter is used and the possible (corrosion) allowance is discarded.

The strengthening shall be carried out in such a way that the shell is subjected to the stress σ_k . The stress in a cylinder is as per [Formula \(D.13\)](#):

$$\sigma = \frac{pD}{20s} \quad (\text{D.13})$$

and the strengthening pressure, p_k , is therefore as per [Formula \(D.14\)](#):

$$p_k = \frac{20s\sigma_k}{D} \quad (\text{D.14})$$

If s according to [Formula \(D.5\)](#) is substituted as per [Formula \(D.15\)](#):

$$p_k = p \frac{S_F}{z} \quad (\text{D.15})$$

Since $S_F = 1,33$ and $\eta = 1,0$, this corresponds to [Formula \(D.4\)](#). Obviously, cylinders can be calculated from the formula in [D.6.1](#) σ_k is inserted as the design stress value and 1,0 as the weld joint factor.

If a weld joint factor less than 1,0 is applied to any single main seam, an increase in strengthening pressure is required according to [Formula \(D.8\)](#). To sustain this higher pressure, the thickness of all parts of the vessel would then need to be increased.

D.6.3.2 If a shell consists of several courses and one of them is made thicker than the others, it will have a lower σ_k than the other courses after strengthening.

The thicker course then needs a higher strengthening pressure than the others. Since this is impossible, this course will fail to satisfy [Formula \(D.12\)](#) (not “strengthened enough”), as the anticipated proof strength σ_k will not be reached.

In order to achieve the full theoretical effect throughout the vessel, it would be necessary to decrease the thickness of the thicker course. Since this would hardly increase the safety of the vessel, it is allowed to use greater thickness in some parts, e.g. where required by external loads, even if this is not theoretically correct.

Correspondingly, constant wall thickness is allowed in conical ends, even though the strengthening theory strictly speaking requires the thickness to be decreased in proportion to the radius. Similarly, the spherical part of a dished end will in some cases be “insufficiently pressure strengthened”.

D.6.3.3 The derivation of the formula in [D.6.3.1](#) applies to parts free from bending stresses, i.e. cylinders, spheres and hemispherical ends.

Use of the strengthening effect is generally not permitted for parts subject to primary bending stresses. For such parts, it is necessary to investigate the stresses during strengthening (see [D.4.2.3.2](#)) and normal operation.

Certain pressure-vessel parts, such as dished and conical ends, contain so-called secondary bending stresses (see [Annex A](#)). It is permissible to use the strengthening effect in such parts, but the magnitude of the secondary bending stresses shall be investigated and should normally not exceed $2\sigma_k$.

Excepted from this, requirement of investigation are 2:1 torispherical ends, where experience has shown the bending stresses to be moderate.

D.6.3.4 Experience has shown that it is possible to use design stress values for pressure-strengthened material when dimensioning reinforcement pads according to [10.3.6.7](#).

D.6.3.5 This Annex does not preclude the use of the strengthening effect, provided that the manufacturer can show it does not cause harmful deformation or other problems.

D.6.4 Deformations at strengthening

D.6.4.1 The highest allowable design stress value $\sigma_{k\max}$ for the different steels has consistently been set 200 N/mm² higher than $R_{p0,2}$ for the solution heat-treated material.

In conventional tensile testing, this maximum stress produces less than 10 % elongation.

D.6.4.2 The strengthening process can be simulated in tensile testing by allowing extra time under load. This increases the elongation under maximum stress by another 1 % to 2 %.

After simulated strengthening, the proof strength, $R_{p0,2}$, of the material (calculated on basis of the cross-sectional area before the strengthening) is about 30 N/mm² higher than the strengthening stress σ_k used.

D.6.4.3 A multi-axial stress state results in other elongation values than tensile testing. These elongation values can be assessed according to a graph of the deformation hardening of the material as applied to the effective values of stress σ and elongation ε [see [Formulae \(D.16\)](#) and [\(D.17\)](#)]:

$$\sigma = \sqrt{\frac{1}{2} \left[(\sigma_1 - \sigma_2)^2 + (\sigma_2 - \sigma_3)^2 + (\sigma_3 - \sigma_1)^2 \right]} \quad (\text{D.16})$$

$$\varepsilon = \sqrt{\frac{2}{9} \left[(\varepsilon_1 - \varepsilon_2)^2 + (\varepsilon_2 - \varepsilon_3)^2 + (\varepsilon_3 - \varepsilon_1)^2 \right]} \quad (\text{D.17})$$

If the effective values are set = 1, the principal stresses and elongations obtained for the simplest stress conditions are given in [Table D.4](#).

Table D.4 — Stresses and elongations for different load cases

	True stress				True elongation			
	σ_1	σ_2	σ_3	σ	ε_1	ε_2	ε_3	ε
Tensile test	1	0	0	1	1	-0,5	-0,5	1
Cylinder	1,15	0,58	0	1	0,87	0	-0,87	1
Sphere	1	1	0	1	0,5	0,5	-1	1

Among other things, [Table D.4](#) expresses the fact that a tensile test sample contracts in two dimensions, while a cylinder decreases only in thickness by an amount corresponding to the increased circumference.

[Table D.4](#) shows that a certain effective stress, σ , produces different elongations in the principal stress direction ε_1 for the different load cases. The same effective stress that produces a strain of 10 % in a tensile test ($\varepsilon_1 = 1,0$) produces a circumferential strain 8,7 % ($\varepsilon_1 = 0,87$) in a cylinder shell and 5 % ($\varepsilon_1 = 0,5$) in a sphere.

The true stresses σ_1 , σ_2 , σ_3 and σ are calculated on basis of the cross-sectional area of the material after deformation. If instead the nominal stresses are used, calculated on the basis of the original cross-sectional area of the material, the comparison of strains will be different.

The following example gives an indication of the difference.

EXAMPLE Values from a typical deformation-hardening curve of austenitic stainless steel are used, i.e. 0,2 %/280 N/mm² and 10 %/420 N/mm². If equal nominal principal stresses, $\sigma_{1\text{nom}}$, are applied to this material, the principal strain ε_1 for the cylinder is altered from 0,87 to 0,66 and for the sphere from 0,5 to 0,58.

The strain at bursting pressure is half of the maximum homogeneous strain at tensile testing for a cylinder and one-third for a sphere.

D.6.4.4 In practice, the maximum circumferential strain of cylinders is usually 3 % to 5 % when using a solution heat-treated plate, less in the spherical part of the ends. The following factors contribute to the measured values being lower than the theoretically calculated maximum value:

- the proof strength $R_{p0,2}$ is higher than the specified minimum for the material;
- the plate thickness is greater than nominal;
- there are reinforcing effects of ends, nozzles, and D .

D.6.4.5 It should be observed that strengthening of pressure vessels of solution heat-treated material can affect the position, direction and roundness of nozzles. This does not entail any reduction of the safety of the vessel, but can in certain cases be a nuisance to the user.

NOTE One way to minimize these changes is to weld the nozzles in place after the strengthening, where the vessel can require renewed strengthening (see [D.5.3](#)). This second strengthening generally leads to much smaller deformations.

D.6.4.6 When a welded tube is used for nozzles in a cylinder (or cone), the longitudinal weld of the tube should be located in the direction where the stresses are lowest, i.e. in a plane perpendicular to the longitudinal axis of the cylinder (or cone).

Annex E (informative)

Specific weld details

E.1 Field of application

Specific weld details given in [E.2](#) are currently in common usage in cryogenic vessels and are appropriate to this service.

E.2 Weld detail

In general, the welds are to be adequate to carry the expected loads and do not need to be designed on the basis of joint wall thickness.

E.2.1 Joggle joint

The joggle joint is not allowed if [Annex D](#) applied. For fatigue evaluation, it is recommended to see the restrictions of the applied standard.

See [Figure E.1](#).

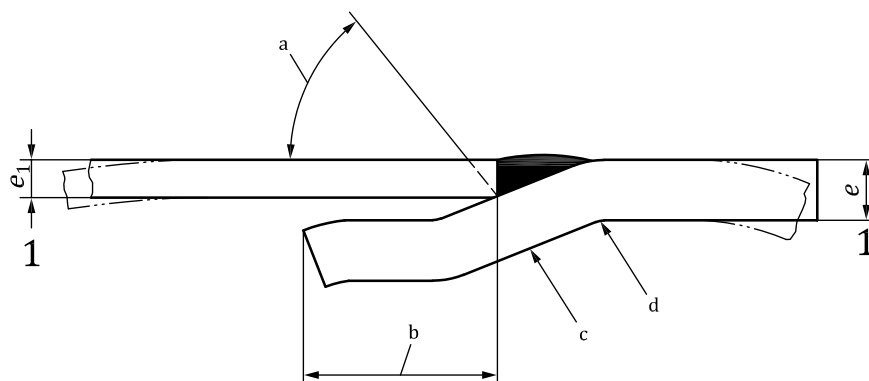

Key

- a Bevel optional.
- b As desired.
- c Depth of offset = e_1 .
- d Avoid sharp break.

Figure E.1 — Joggle joint

This joint may be used for cylinder to cylinder and end to cylinder (excluding cone to cylinder) connections provided that:

- a) when the flanged section of a dished end is joggled, the joggle is sufficiently clear of the knuckle radius to ensure that the edge of the circumferential seam is at least 12 mm clear of the knuckle (see [10.3.6.4.2](#) for the dimensions);

- b) when a cylinder with a longitudinal seam (butt welded) is joggled to make a circumferential weld:
- 1) the welds are ground flush internally and externally for a distance of approximately 50 mm prior to joggling with no reduction of plate thickness below the required minimum; and
 - 2) on completion of joggling, the area of the weld is subjected to dye-penetrant examination and is proven to be free of cracks;
- c) the offset section which forms the weld backing is a close fit within its mating section at the weld round the entire circumference;
- d) the profile of the offset is a smooth radius without sharp corners;
- e) on completion of welding, the weld fills the groove smoothly to the full thickness of the plate edges being joined;
- f) the junction of the longitudinal and circumferential seams are examined radiographically and found to be free from significant imperfections.

E.2.2 Intermediate ends

See [Figure E.2](#) and [10.3.6.4.3](#).

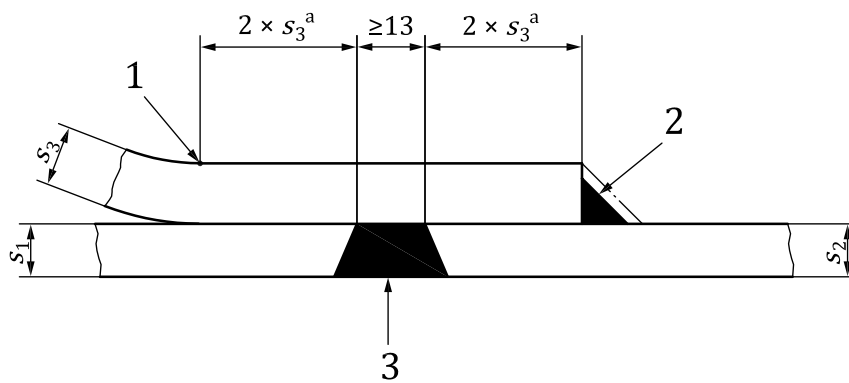

Key

- 1 tangent point
- 2 continuous fillet weld
- 3 butt weld
- s_1 cylinder thickness
- s_2 cylinder thickness
- s_3 end thickness
- ^a Not to exceed 25 mm.

NOTE s_1 and s_2 cannot be equal.

Figure E.2 — Intermediate end

E.2.3 Backing strip

See [Figure E.3](#).

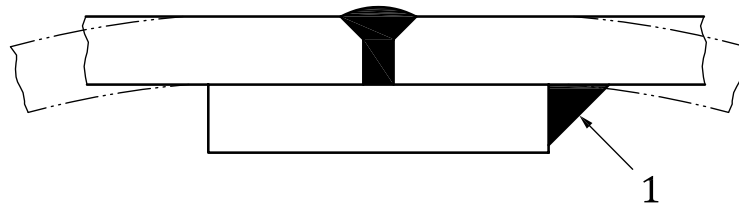

Key

- 1 intermittent or continuous fillet weld

Figure E.3 — Backing strip

The backing strip may be used only for circumferential seams in cylinders, ends, nozzles and interspace pipes, when the second side is inaccessible for welding and provided that non-destructive testing can be satisfactorily carried out where applicable.

E.2.4 End plate closure

See [Figure E.4](#) for two examples of the many ways of welding flat plates. See also [Figure 6](#).

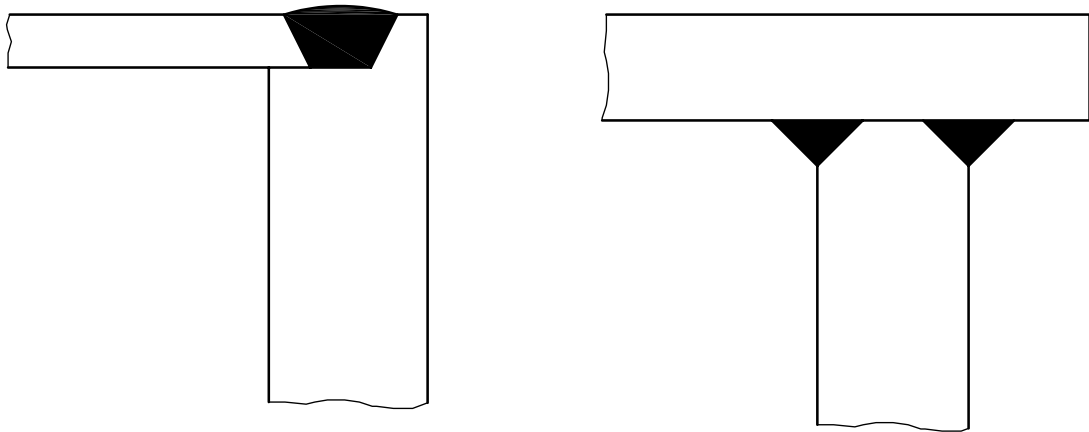

Figure E.4 — End plate closure (examples)

E.2.5 Nozzle weld

See [Figure E.5](#).

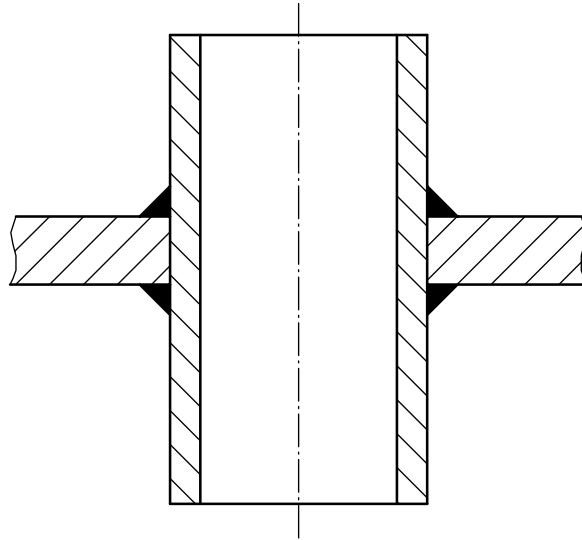

Figure E.5 — Non-full penetration nozzle welds,

Special care shall be taken for welding nozzles used for filling or emptying cryogenic vessels (with flow) due to the thermal gradient between the nozzle and the vessel.

Full penetrated welding seams shall be used for nozzle connections where thermal conditions according to [Clause 8](#) are relevant or if [Annex D](#) is applied, where significant plastic deformation/strain during cold stretching.

E.2.6 Non-continuous fillet weld on attachments

Non-continuous fillet welds on attachments may be used for all attachments to main pressure components provided that the following criteria are met:

- strength is adequate for design loadings;
- crevices between attached component and main pressure envelope can be demonstrated not to conflict with [E.3](#).

E.3 Oxygen service requirements

The need for cleanliness of equipment in liquid oxygen and other oxidizing liquid service is described in ISO 21010 and ISO 23208.

The internal weld details shall be such that debris, contaminants, hydrocarbons or degreasants cannot accumulate so as to cause a fire risk in future operation.

Annex F **(normative)**

Outer-jacket relief devices

F.1 Field of application

This annex covers the requirements for design, manufacture and testing of pressure-protection devices required on outer jackets of vacuum-insulated cryogenic vessels in order to reduce any accidental accumulation of pressure.

F.2 Requirements

F.2.1 General

The device shall be either a relief plate/plug or a bursting disc.

Bursting disc devices shall be in accordance with ISO 4126-2.

F.2.2 Design

The pressure-protection device shall be capable of withstanding full vacuum and all demands of normal vessel operation, including its own mass acceleration during transportation.

The set pressure and the open relieving area are specified in [10.2.7.2](#). Consideration shall be given to prevention of blocking of the device by insulation materials during operation.

The plate or plug of a relief plate/plug type device shall be designed and installed such that it cannot harm personnel when ejected.

F.2.3 Materials

The pressure-protection devices shall be resistant to normal atmospheric corrosion. The materials of construction shall be suitable for the range of ambient temperatures expected in service.

F.2.4 Testing

Relief plate/plug type relieving devices shall not require testing other than a prototype test to verify the set pressure.

Burst disc assemblies shall be tested in accordance with ISO 4126-2.

F.2.5 Inspection

Relief plate/plug type devices shall be subjected to an inspection programme that ensures compliance with the drawings or specification.

Bursting discs shall be inspected in accordance with ISO 4126-2.

F.2.6 Marking

Bursting discs shall be certified and marked in accordance with ISO 4126-2.

Other pressure-protection devices shall be marked in accordance with this document.

Annex G (informative)

Base materials

See Tables G.1 and G.2.

Table G.1 — Pressure vessels

Specification No.	Material grade	Material number	Material Group ISO/TR 15608:2017
EN 10028-3	P275NL1	1.0488	1.1
EN 10028-3	P275NL2	1.1104	1.1
EN 10028-3	P355NL1	1.0566	1.2
EN 10028-3	P355NL2	1.1106	1.2
EN 10028-3	P460NL1	1.8915	1.3
EN 10028-3	P460NL2	1.8916	1.3
EN 10028-4	X8Ni9	1.5662	9.3
EN 10028-5	P355ML1	1.8832	1.2
EN 10028-5	P355ML2	1.8833	1.2
EN 10028-5	P420ML1	1.8835	2.1
EN 10028-5	P420ML2	1.8828	2.1
EN 10028-5	P460ML1	1.8837	2.1
EN 10028-5	P460ML2	1.8831	2.1
EN 10028-7	X2CrNi18-9	1.4307	8.1
EN 10028-7	X2CrNi19-11	1.4306	8.1
EN 10028-7	X2CrNiN18-10	1.4311	8.1
EN 10028-7	X5CrNi19-9	1.4315	8.1
EN 10028-7	X5CrNi18-10	1.4301	8.1
EN 10028-7	X2CrMnNiN21-5-1	1.4162	10.3
EN 10028-7	X2CrNiN23-4	1.4362	10.1
EN 10028-7	X3CrNiMo17-12-2	1.4401	8.1
EN 10028-7	X2CrNiMo17-12-2	1.4404	8.1
EN 10028-7	X2CrNiMoN17-11-2	1.4406	8.1
EN 10028-7	X2CrNiMoN17-13-3	1.4429	8.1
EN 10028-7	X2CrNiMoN22-5-3	1.4462	10.1
EN 10028-7	X2CrNiMoCuN25-6-3	1.4507	10.2
EN 10028-7	X2CrNiMoN25-7-4	1.4410	10.2
EN 10028-7	X2CrNiMoCuWN25-7-4	1.4501	10.2
EN 10222-3	X8Ni9	1.5662	9.3
EN 10222-5	X2CrNi18-9	1.4307	8.1
EN 10222-5	X5CrNi18-10	1.4301	8.1
EN 10222-5	X5CrNiMo17-12-2	1.4401	8.1
EN 10222-5	X2CrNiMo17-12-2	1.4404	8.1
EN 10088-3	X2CrNi19-11	1.4306	8.1

Table G.1 (continued)

Specification No.	Material grade	Material number	Material Group ISO/TR 15608:2017
EN 10088-3	X2CrNi18-10	1.4311	8.1
EN 10088-3	X5CrNi18-10	1.4301	8.1
EN 10088-3	X5CrNiMo17-12-2	1.4401	8.1
EN 10088-3	X2CrNiMo17-13-2	1.4404	8.1
EN 10088-3	X2CrNiMoN17-12-2	1.4406	8.1
EN 10088-3	X2CrNiMo17-13-3	1.4429	8.1
EN 14286	AlMg3	EN AW 5754 O H111	22.3
EN 14286	AlMg3Mn	EN AW 5454 O H111	22.3
EN 14286	AlMg5,5MnZnZr	EN AW 5059 O H111	22.4
EN 14286	AlMg4,5Mn0,4	EN AW 5182 O H111	22.4
EN 14286	AlMg4Mn0,4	EN AW 5088 O H111	22.4
EN 14286	AlMg4,5Mn0,7	EN AW 5083 O H111	22.4
EN 14286	AlMg4,5Mn0,9	EN AW 5383 O H111	22.4
EN 14286	AlMg4	EN AW 5086 O H111	22.4
EN 14286	AlMg4Mn0,4	EN AW 5186 O H111	22.4
VDTUEV WB 521	Elongal	EN AW 5186 O H111	22.4
JIS G 3127	SL9N520	1.5662	9.3
JIS G 4303-4305	SUS304	1.4301	8.1
JIS G 4303-4305	SUS304L	1.4307	8.1
JIS G 4303-4305	SUS316	1.4401	8.1
JIS G 4303-4305	SUS316L	1.4404	8.1
JIS G 4317-4320	SUS321	1.4541	8.1
JIS G 4317-4320	SUS347	1.4550	8.1
JIS G 4317-4320	SUS316	1.4401	8.1
JIS G 4317-4320	SUS316L	1.4404	8.1
JIS G 4317-4320	SUS317L	1.4439	8.1
JIS G 4313-4315	SUS304	1.4301	8.1
JIS G 4313-4315	SUS304L	1.4307	8.1
JIS G 4313-4315	SUS304N1	1.4406	8.1
JIS G 4313-4315	SUS304LN	1.4311	8.1
JIS G 4317-4320	SUS316L	1.4406	8.1
JIS G 4315-4315	SUS316LN	1.4429	8.1
SA/A-240	304LN	S 30453	8.1
SA/A-240	304N	S 30451	8.1
SA/A-240	316LN	S 31653	8.1
SA/A-240	316N	S 31651	8.1
SA/A-240	201LN	S 20153	8.3
SA/A-240	201-1	S 20100	8.3
SA/A-666	201-1	S 20100	8.3
SA/A-240	201-2	S 20100	8.3
SA/A-666	201-2	S 20100	8.3
SA/A-240	201L	S 20103	8.3
SA/A-666	201L	S 20103	8.3

Table G.1 (continued)

Specification No.	Material grade	Material number	Material Group ISO/TR 15608:2017
SA/A-479	316LN	S 31653	8.1
SA/A-479	316N	S 31651	8.1
SA/A-240	XM-29	S 24000	8.3
SA/A-479	XM-29	S 24000	8.3
SA/A-479	304	S 30400	8.1
SA/A-479	304L	S 30403	8.1
SA/A-240	304	S 30400	8.1
SA/A-240	304L	S 30403	8.1
SA/A-479	304LN	S 30453	8.1
SA/A-479	304N	S 30451	8.1
SA/A-240	XM-19	S 20910	8.3
SA/A-479	XM-19	S 20910	8.3
SA/A-479	—	S 21800	8.1
SA/A-353	—	K 81340	9.3
SA/A-553	1	K 81340	9.3
SA/A-522	1	K 81340	9.3
SA/A-553	2	K 71340	9.3
SA/A-351	—	—	45
SA/A-516	55	K 01800	1.1
SA/A-516	60	K 02100	1.1
SA/A-516	65	K 02403	1.1
SA/A-516	70	K 02700	11.1
SA/A-517	E	K 21604	3.1
SA/A-517	F	K 11576	3.1
SA/A-612	—	K 02900	1.3
A-276	201LN	S 20153	8.3
A-276	304	S 30400	8.1
A-276	304L	S 30403	8.1
A-276	304LN	S 30453	8.1
A-276	304N	S 30451	8.1
A-276	316	S 31600	8.1
A-276	316L	S 31603	8.1
A-276	316LN	S 31653	8.1
A-276	316N	S 31651	8.1
A-276	201	S 20100	8.3
A-276	XM-29	S 24000	8.3
A-276	XM-19	S 20910	8.3
A-276	—	S 21800	8.1
SB/B-209	5083	A 95083	22.4
SB/B-221	5083	A 95083	22.4
SB/B-209	6061	A 96061	23.1
SB/B-221	6061	A 96061	23.1
SB/B-211	6061	A 96061	23.1

Table G.1 (continued)

Specification No.	Material grade	Material number	Material Group ISO/TR 15608:2017
SB/B-308	6061	A 96061	23.1
SB/B-209	3003	A 93003	22.1
SB/B-209	5052	A 95052	22.3
SB/B-211	3003	A 93003	22.1
SB/B-221	3003	A 93003	22.1
B-221	6063	A 96063	23.1
B-187	—	—	37
B-16	—	—	32
GB 3531	16MnDR	—	1.2
GB 3531	15MnNiDR	—	9.1
GB 3531	09MnNiDR	—	9.1
GB 150.2	08Ni3DR	—	9.2
GB 150.2	06Ni9DR	—	9.3
GB 24511	06Cr19Ni10	S30408	8.1
GB 24511	022Cr19Ni10	S30403	8.1
GB 24511	06Cr17Ni12Mo2	S31608	8.1
GB 24511	022Cr17Ni12Mo2	S31603	8.1

NOTE SA/SB prefix to specification number refers to ASME specifications. A/B prefix to specification number refers to ASTM specifications. When materials to ASME specifications are unavailable, materials to the same specification number with a prefix of A/B (ASTM) may be used. All ASME/ASTM specification numbers listed are equally acceptable with a suffix M.

Table G.2 — Piping and pipe fittings

Specification No.	Material grade	Material number	Material Group ISO/TR 15608:2017
EN 10216-5-	X5CrNi18-10	1.4301	8.1
EN 10216-5	X2CrNi19-11	1.4306	8.1
EN 10216-5	X2CrNi18-9	1.4307	8.1
EN 10216-5	X5CrNiMo17-12-2	1.4401	8.1
EN 10216-5	X2CrNiMo17-12-2	1.4404	8.1
EN 10216-5	X6CrNiTi18-10	1.4541	8.1
EN 10216-5	X6CrNiMoTi17-12-2	1.4571	8.1
EN 10217-7	X5CrNi18-10	1.4301	8.1
EN 10217-7	X2CrNi19-11	1.4306	8.1
EN 10217-7	X2CrNi18-9	1.4307	8.1
EN 10217-7	X5CrNiMo17-12-2	1.4401	8.1
EN 10217-7	X2CrNiMo17-12-2	1.4404	8.1
EN 10217-7	X6CrNiTi18-10	1.4541	8.1
EN 10217-7	X6CrNiMoTi17-12-2	1.4571	8.1
EN 10253-4	X5CrNi18-10	1.4301	8.1
EN 10253-4	X2CrNi19-11	1.4306	8.1
EN 10253-4	X2CrNi18-9	1.4307	8.1
EN 10253-4	X5CrNiMo17-12-2	1.4401	8.1

Table G.2 (continued)

Specification No.	Material grade	Material number	Material Group ISO/TR 15608:2017
EN 10253-4	X2CrNiMo17-12-2	1.4404	8.1
EN 10253-4	X6CrNiTi18-10	1.4541	8.1
EN 10253-4	X6CrNiTi18-10	1.4571	8.1
SA/A-312	TP 316L	S 31603	8.1
SA/A-358	TP 316L	S 31603	8.1
SA/A-249	TP 316L	S 31603	8.1
SA/A-409	TP 316L	S 31603	8.1
SA/A-688	TP 316L	S 31603	8.1
SA/A-813	TP 316L	S 31603	8.1
SA/A-814	TP 316L	S 31603	8.1
SA/A-249	TP 316	S 31600	8.1
SA/A-312	TP 316	S 31600	8.1
SA/A-358	TP 316	S 31600	8.1
SA/A-409	TP 316	S 31600	8.1
SA/A-688	TP 316	S 31600	8.1
SA/A-813	TP 316	S 31600	8.1
SA/A-814	TP 316	S 31600	8.1
SA/A-249	TP 316LN	S 31653	8.1
SA/A-312	TP 316LN	S 31653	8.1
SA/A-358	TP 316LN	S 31653	8.1
SA/A-688	TP 316LN	S 31653	8.1
SA/A-249	TP 316N	S 31651	8.1
SA/A-312	TP 316N	S 31651	8.1
SA/A-358	TP 316N	S 31651	8.1
SA/A-688	TP 316N	S 31651	8.1
SA/A-813	TP 316N	S 31651	8.1
SA/A-814	TP 316N	S 31651	8.1
SA/A-249	TPXM-29	S 24000	8.3
SA/A-312	TPXM-29	S 24000	8.3
SA/A-688	TPXM-29	S 24000	8.3
SA/A-249	TP 304L	S 30403	8.1
SA/A-312	TP 304L	S 30403	8.1
SA/A-358	TP 304L	S 30403	8.1
SA/A-409	TP 304L	S 30403	8.1
SA/A-688	TP 304L	S 30403	8.1
SA/A-813	TP 304L	S 30403	8.1
SA/A-814	TP 304L	S 30403	8.1
SA/A-249	TP 304	S 30400	8.1
SA/A-334	8	K 81340	9.3
SA/A-333	8	K 81340	9.3
SA/A-312	TP 304	S 30400	8.1
SA/A-358	TP 304	S 30400	8.1
SA/A-409	TP 304	S 30400	8.1

Table G.2 (continued)

Specification No.	Material grade	Material number	Material Group ISO/TR 15608:2017
SA/A-688	TP 304	S 30400	8.1
SA/A-813	TP 304	S 30400	8.1
SA/A-814	TP 304	S 30400	8.1
SA/A-249	TP 304LN	S 30453	8.1
SA/A-312	TP 304LN	S 30453	8.1
SA/A-358	TP 304LN	S 30453	8.1
SA/A-688	TP 304LN	S 30453	8.1
SA/A-813	TP 304LN	S 30453	8.1
SA/A-814	TP 304LN	S 30453	8.1
SA/A-249	TP 304N	S 30451	8.1
SA/A-312	TP 304N	S 30451	8.1
SA/A-358	TP 304N	S 30451	8.1
SA/A-688	TP 304N	S 30451	8.1
SA/A-813	TP 304N	S 30451	8.1
SA/A-814	TP 304N	S 30451	8.1
SA/A-312	TP 321	S 32100	8.1
SA/A-249	TP 321	S 32100	8.1
SA/A-358	TP 321	S 32100	8.1
SA/A-409	TP 321	S 32100	8.1
SA/A-813	TP 321	S 32100	8.1
SA/A-814	TP 321	S 32100	8.1
SA/A-213	TP 316L	S 31603	8.1
SA/A-312	TP 316L	S 31603	8.1
SA/A-430	FP 316	S 31600	8.1
SA/A-213	TP 316	S 31600	8.1
SA/A-312	TP 316	S 31600	8.1
SA/A-376	TP 316	S 31600	8.1
SA/A-213	TP 316LN	S 31653	8.1
SA/A-312	TP 316LN	S 31653	8.1
SA/A-376	TP 316LN	S 31653	8.1
SA/A-430	FP 316N	S 31651	8.1
SA/A-213	TP 316N	S 31651	8.1
SA/A-312	TP 316N	S 31651	8.1
SA/A-376	TP 316N	S 31651	8.1
SA/A-182	F 316L	S 31603	8.1
SA/A-336	F 316L	S 31603	8.1
SA/A-403	316L	S 31603	8.1
SA/A-182	F 316	S 31600	8.1
SA/A-336	F 316L	S 31600	8.1
SA/A-403	316	S 31600	8.1
SA/A-182	F 316LN	S 31653	8.1
SA/A-336	F 316LN	S 31653	8.1
SA/A-403	316LN	S 31653	8.1

Table G.2 (continued)

Specification No.	Material grade	Material number	Material Group ISO/TR 15608:2017
SA/A-182	F 316N	S 31651	8.1
SA/A-336	F 316N	S 31651	8.1
SA/A-403	316N	S 31651	8.1
SA/A-182	F 304L	S 30403	8.1
SA/A-336	F 304L	S 30403	8.1
SA/A-403	304L	S 30403	8.1
SA/A-182	F 304	S 30400	8.1
SA/A-336	F 304	S 30400	8.1
SA/A-403	304	S 30400	8.1
SA/A-182	F 304LN	S 30453	8.1
SA/A-336	F 304LN	S 30453	8.1
SA/A-403	304LN	S 30453	8.1
SA/A-182	F 304N	S 30451	8.1
SA/A-336	F 304N	S 30451	8.1
SA/A-403	304N	S 30451	8.1
SA/A-552	I	K 81340	9.3
SA/A-420	WPL8	K 81340	9.3
SA/A-213	TP 304L	S 30403	8.1
SA/A-213	TP 304	S 30400	8.1
SA/A-213	TP 304LN	S 30453	8.1
SA/A-213	TP 304N	S 30451	8.1
SA/A-430	FP 304	S 30400	8.1
SA/A-430	FP 304N	S 30451	8.1
SA/A-376	TP 304LN	S 30453	8.1
SA/A-376	TP 304	S 30400	8.1
SA/A-376	TP 304N	S 30451	8.1
SA/A-376	TP 316LN	S 31653	8.1
SA/A-376	TP 316	S 31600	8.1
SA/A-376	TP 316N	S 31651	8.1
SA/A-213	TP 321	S 32100	8.1
SA/A-333	1	K 03008	11.1
SA/A-333	2	—	—
SA/A-333	3	K 31918	9.2
SA/A-333	4	K 11267	4.1
SA/A-333	5	—	—
SA/A-333	6	K 03006	11.1
SA/A-333	7	K 21903	9.1
SA/A-333	8	K 81340	9.3
SA/A-333	9	K 22035	9.1
SA/A-333	10	—	1.3
SA/A-333	11	—	48
SA/A-105		K 03504	11.1
SA/A-350	LF-1	K 03504	11.1

Table G.2 (continued)

Specification No.	Material grade	Material number	Material Group ISO/TR 15608:2017
SA/A-350	LF 2	K 03009	11.1
SA/A-350	LF 3	K 03011	9.2
SA/A-350	LF 5	K 13050	9.1
SA/A-350	LF 6	—	1.3
SA/A-350	LF 9	K 22036	9.1
SA/A-350	LF 787	—	9.1
SA/A-106	A	K 02501	1.1
SA/A-106	B	K 03006	11.1
SA/A-106	C	K 03501	11.1
SB/B-247	5083	A 95083	22.4
SB/B-247	6061	A 96061	23.1
SB/B-241	5083	A 95083	22.2
SB/B-241	6061	A 96061	23.1
SB/B-210	6061	A 96061	23.1
SB/B-241	3003	A93003	22.1
SB/B-75	—	—	31
A-511	TP 304	S 30400	8.1
A-511	TP 304L	S 30403	8.1
A-511	TP 316L	S 31603	8.1
A-511	TP 316	S 31600	8.1
A-511	TP 321	S 32100	8.1
A-351	304	S 30400	8.1
A-351	316	S 31600	8.1
A-351	304L	S 30403	8.1
A-351	316L	S 31603	8.1
A-269	TP 316L	S 31603	8.1
A-269	TP 316	S 31600	8.1
A-269	TP 316LN	S 31653	8.1
A-269	TP 316 N	S 31651	8.1
A-269	TP 304L	S 30403	8.1
A-269	TP 304	S 30400	8.1
A-269	TP 304LN	S 30453	8.1
A-269	TP 304N	S 30451	8.1
A-269	TP 321	S 32100	8.1
A-269	TPXM 29	S 24000	8.1
A-632	TP 304L	S 30403	8.1
A-632	TP 304	S 30400	8.1
A-632	TP 316L	S 31603	8.1
A-632	TP 316	S 31600	8.1
A-632	TP 321	S 32100	8.1
A-733	TP 304L	S 30403	8.1
A-733	TP 304	S 30400	8.1
A-733	TP 316L	S 31603	8.1

Table G.2 (continued)

Specification No.	Material grade	Material number	Material Group ISO/TR 15608:2017
A-733	TP 316	S 31600	8.1

NOTE SA/SB prefix to specification number refers to ASME specifications. A/B prefix to specification number refers to ASTM specifications. When materials to ASME specifications are unavailable, materials to the same specification number with a prefix of A/B (ASTM) can be used. All ASME/ASTM specification numbers listed are equally acceptable with a suffix M.

Annex H (informative)

Components subject to external pressure (pressure on the convex surface) — Calculation

H.1 General

This annex gives two calculation methods which are equally recognized and which give comparable results.

Calculations are performed for elastic buckling and for plastic deformation. The lowest calculated pressure, p_e or p_p , shall not be less than the external design pressure.

NOTE The buckling length, l_b is the maximum length of the shell supported by a reinforcement ring as defined in [Figure H.1](#).

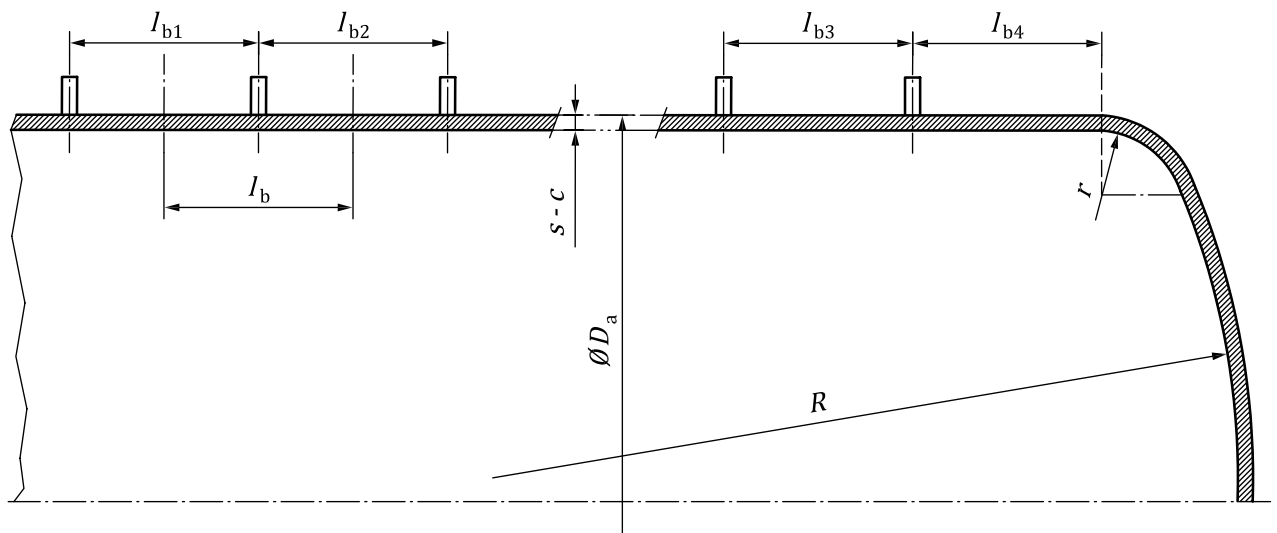

Key

l_b = maximum of l_{b1} , l_{b2} , l_{b3} , l_{b4} for design of cylindrical shell

l_b = $\frac{l_{b1} + l_{b2}}{2}$ for design of reinforcing elements

Figure H.1 — Determination of buckling length

H.2 Method 1

H.2.1 Cylindrical shells

H.2.1.1 Elastic buckling

Calculations are performed using [Formula \(H.1\)](#):

$$p_e = \frac{E}{S_k} \left\{ \frac{20}{(n^2 - 1) \left[1 + (n/Z)^2 \right]^2} \frac{s-c}{D_a} \frac{80}{12(1-\nu^2)} \left[n^2 - 1 + \frac{2n^2 - 1 - \nu}{1 + (n/Z)^2} \right] \left[\frac{s-c}{D_a} \right]^3 \right\} \quad (\text{H.1})$$

where $Z = 0,5\pi(D_a/l_b)$ and n is an integer equal to or greater than 2 and greater than Z , so determined that the value for p_e is a minimum. n denotes the number of lobes produced by the buckling process which may occur at the circumference in the event of failure. The number of lobes can be estimated using approximation [Formula \(H.2\)](#):

$$n = 1,63 \left(\frac{D_a^3}{l_b^2 (s-c)} \right)^{0,25} \quad (\text{H.2})$$

For tubes and pipes, calculations may be performed using simplified [Formula \(H.3\)](#):

$$p_e = \frac{E}{S_k} \times \frac{20}{1-\nu^2} \times \left(\frac{s-c}{D_a} \right)^3 \quad (\text{H.3})$$

H.2.1.2 Plastic deformation

When $D_a/l_b \leq 5$, [Formula \(H.4\)](#) applies:

$$p_p = \frac{20K}{S_p} \times \frac{s-c}{D_a} \times \frac{1}{1 + \frac{1,5u(1-0,2D_a/l_b)D_a}{100(s-c)}} \quad (\text{H.4})$$

When $D_a/l_b > 5$, [Formulae \(H.5\)](#) and [\(H.6\)](#) apply.

The higher pressure obtained using [Formulae \(H.5\)](#) and [\(H.6\)](#) shall not be less than the external design pressure.

$$p_p = \frac{20K}{S_p} \frac{(s-c)}{D_a} \quad (\text{H.5})$$

$$p_p = \frac{30K}{S_p} \times \left(\frac{s-c}{l_b} \right)^2 \quad (\text{H.6})$$

H.2.1.3 Stiffening rings

In addition to the ends, effective reinforcing elements may be regarded as including the types of element illustrated in [Figure H.2](#).

$$h/ea \leq 16$$

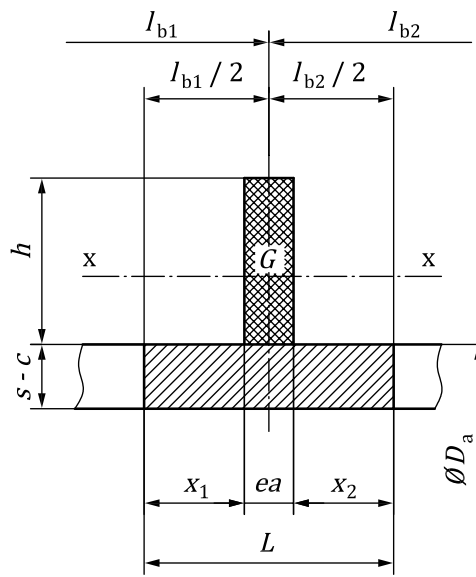

$$x_1 = 0,55\sqrt{D_a(s-c)}$$

$$x_1 \leq \frac{l_{b1} - ea}{2}$$

$$x_2 = 0,55\sqrt{D_a(s-c)} \leq \frac{l_{b2} - ea}{2}$$

a)

Min of

$$h/ea \leq 50$$

$$b \leq ea + 0,55\sqrt{D_a \times es}$$

$$b \leq ea + 16es$$

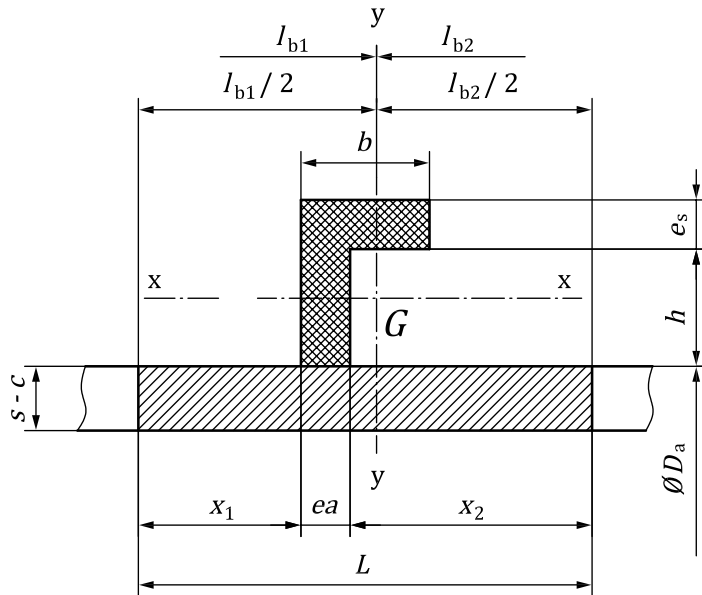

$$x_1 = 0,55\sqrt{D_a (s-c)} + ea \leq \frac{l_{b1}}{2}$$

$$x_2 = 0,5\sqrt{D_a (s-c)} \leq \frac{l_{b2}}{2}$$

NOTE In [Figure H.2 b](#)), yy may be taken through the centre line of the vertical leg of reinforcement for simplifying calculations; in this case the equations are similar.

b)

Min of

$$h/ea \leq 50$$

$$b \leq ea + 1 \times 1 \sqrt{D_a \times es}$$

$$b \leq ea + 32es$$

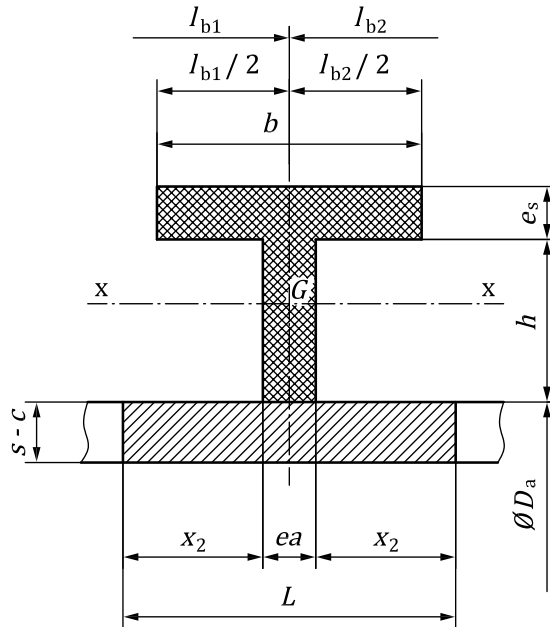

$$x_1 = 0,55 \sqrt{D_a (s-c)}$$

$$x_1 \leq \frac{l_{b1} - ea}{2}$$

$$x_2 = 0,55 \sqrt{D_a (s-c)} \leq \frac{l_{b2} - ea}{2}$$

c)

Min of

$$h/ea \leq 50$$

$$b \leq ea + 1 \times 1 \sqrt{D_a \times es}$$

$$b \leq ea + 32es$$

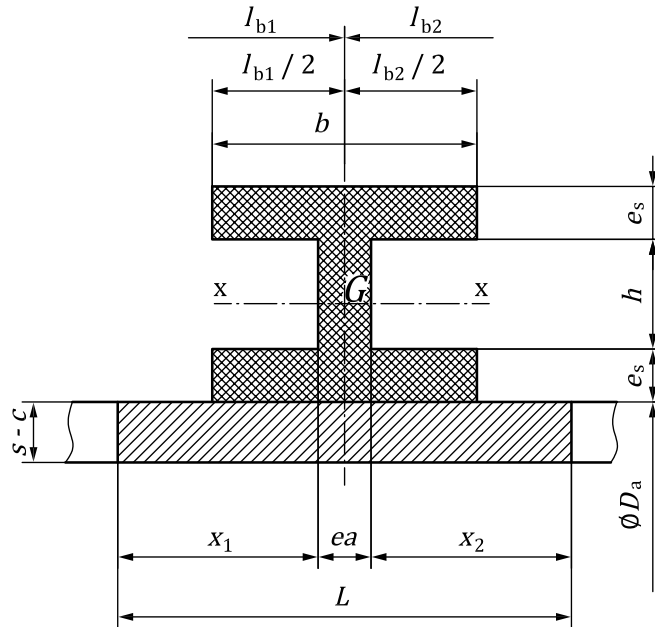

$$x_1 = 0,55 \sqrt{D_a (s-c)}$$

$$x_1 \leq \frac{l_{b1} - ea}{2}$$

$$x_2 = 0,55 \sqrt{D_a (s-c)} \leq \frac{l_{b2} - ea}{2}$$

d)

$$\frac{h}{ea} \leq 50 \quad b \leq 1 \times 1 \sqrt{D_a \times es}$$

$$b \leq 1 \times 1 \sqrt{D_a (s-c)}$$

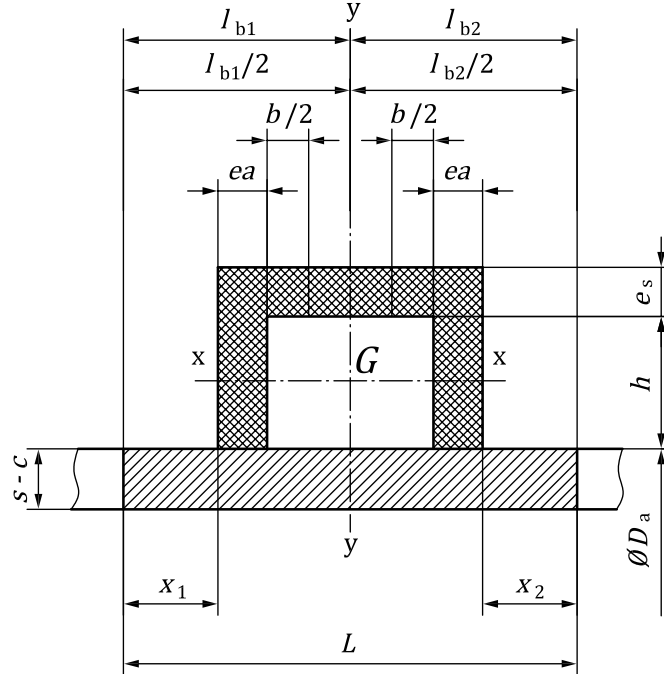

e)

$$x_1 = \min \left\{ 0,55 \sqrt{D_a (s-c)}; \frac{l_{b1}}{2} \right\}$$

$$x_2 = \min \left\{ 0,55 \sqrt{D_a (s-c)}; \frac{l_{b2}}{2} \right\}$$

L is the portion of the shell which acts as part of the reinforcing element and contribute to its effective moment of inertia.

$$L \leq 2,2 \times \sqrt{D_a (s-c)} + 2ea$$

$$L \leq 1,1 \sqrt{D_a - 2y} + 2ea + W_r$$

Figure H.2 — Determination of reinforcing elements

The reinforcing elements, including the stiffening rings welded to the shell and the portion L of the shell (see [Figure H.2](#)), shall satisfy the following conditions [[Formulae \(H.7\)](#) to [\(H.9\)](#)]:

a) for the inner vessel:

$$I \geq 0,124 \times \frac{p \times D_a^3 \times \sqrt{D_a \times s}}{10 \times E} \quad (\text{H.7})$$

b) for the outer jacket:

$$I \geq 0,042S_k \frac{pD_a^3 l'_b}{10E} \quad (\text{H.8})$$

For demonstrated satisfactory experience, a factor of safety S_k equal to or greater than 1,3 is acceptable.

$$A \geq 0,5S_k \frac{pD_a l'_b}{10K} \quad (\text{H.9})$$

The moment of inertia, I , is relative to the neutral axis of the reinforcing element cross-section parallel to the shell axis (see axis xx in [Figure H.2](#)).

The flat-bar stiffness and the Γ , T , H or U profile stiffness shall satisfy the conditions given in [Figure H.2](#). Stiffening rings (full or partial) to provide structural integrity shall be securely attached to the outer jacket.

Where stiffening rings are joined to the shell by means of intermittent welds, the fillet welds at each side shall cover at least one-third of the shell circumference, be uniformly distributed (see [Figure H.3](#)) and the number of weld discontinuities shall be at least $2n$. The number of buckling lobes, n , is obtained as indicated in [H.3.1.2.5](#).

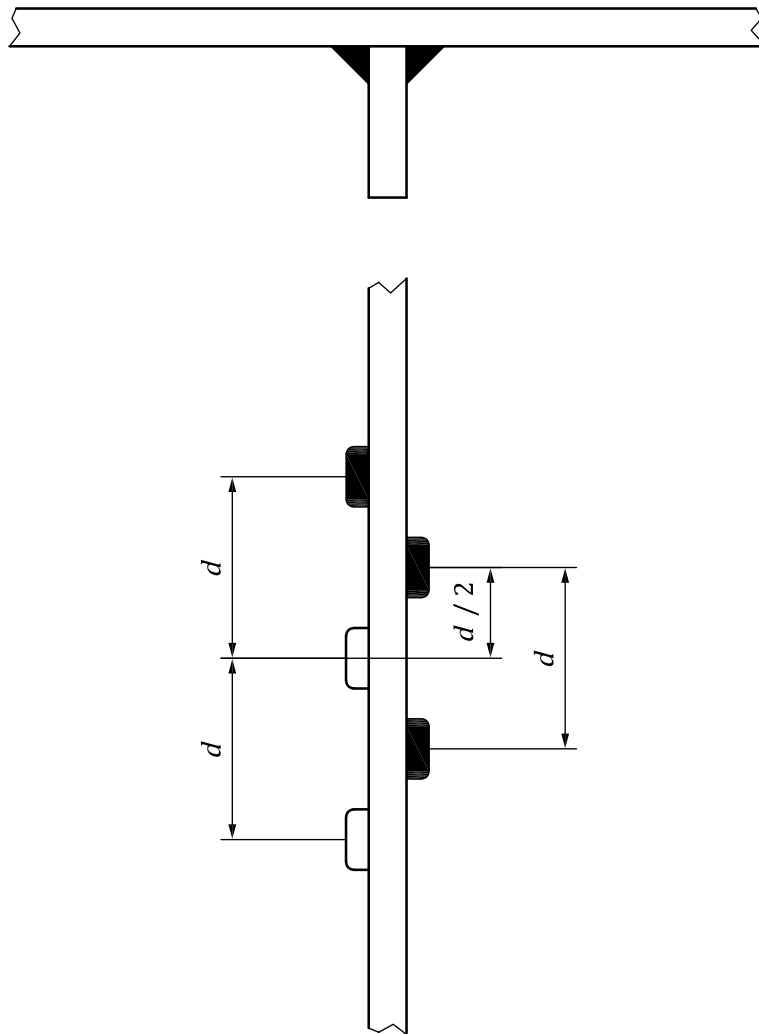

Figure H.3 — Example of joining stiffening ring to shell

H.2.2 Dished ends and spherical shells

H.2.2.1 Elastic buckling

There is adequate resistance to elastic buckling when [Formulae \(H.10\) and \(H.11\)](#) are met:

$$p \leq 3,66 \frac{E}{S_k} \left(\frac{s-c}{R} \right)^2 \quad (10)$$

where

$$S_k = 2,0 + 0,0014 R/(s-c) \quad (H.11)$$

H.3 Method 2

H.3.1 Cylindrical shells

H.3.1.1 Elastic buckling

If [Formula \(H.12\)](#) is met, then [Formula \(H.13\)](#) applies:

$$\frac{l_b}{D_a} > 1,537 \frac{(1-\nu^2)^{0,25}}{\left(\frac{s}{D_a} \right)^{0,5}} \quad (H.12)$$

$$p_e = \frac{E}{S_k} \left(\frac{20}{1-\nu^2} \right) \left(\frac{s-c}{D_a} \right)^3 \quad (H.13)$$

If [Formula \(H.14\)](#) is met, then [Formula \(H.15\)](#) applies:

$$\frac{l_b}{D_a} \leq 1,537 \frac{(1-\nu^2)^{0,25}}{\left(\frac{s}{D_a} \right)^{0,5}} \quad (H.14)$$

$$p_e = \frac{24,2E \left(\frac{s}{D_a} \right)^{2,5}}{S_k (1-\nu^2)^{0,75} \left[\left(\frac{l_b}{D_a} \right) - 0,45 \left(\frac{s}{D_a} \right)^{0,5} \right]} \quad (H.15)$$

H.3.1.2 Stiffening rings

H.3.1.2.1 Each stiffening ring shall have a minimum moment of inertia as determined by either [Formula \(H.16\)](#) or [Formula \(H.17\)](#):

$$I = \frac{S_k p D_a^3 l_b}{280E} \quad (H.16)$$

$$I' = \frac{S_k p D_a^3 l_b}{218E} \quad (\text{H.17})$$

where

- I is the required moment of inertia of the stiffening ring cross-section about its neutral axis parallel to the axis of the shell;
- I' is the required moment of inertia of the combined ring-shell cross-section about its neutral axis parallel to the axis of the shell.

The required amount of inertia of the combined ring-shell section shall be maintained completely around the circumference of the cylinder unless the adequacy of the shell to carry the required critical collapse pressure is demonstrated through the finite element analysis method verified with scale model tests of each type of design.

H.3.1.2.2 If stiffening rings are used in designing the cylindrical portion (shell) of the inner vessel or vacuum jacket for external pressure, each ring shall be attached to the shell by fillet welds. Stiffening ring attachment welds on the outside of the vacuum jacket shall be continuous. All other ring attachment welds may be intermittent. Care should be taken in the design of ring attachments to minimize localized areas of buckling. Where intermittent welds are used, the total length of welds on each side of the ring shall be at least one-third of the shell circumference, or if welded on one side, two-thirds of the shell circumference. The intermittent attachment welds shall be uniformly distributed and if welded on both sides, shall be staggered as shown in [Figure H.3](#).

A portion of the shell may be included when calculating the moment of inertia of the ring. The effective width of shell plate, x , on each side of the attachment to the ring is given by [Formula \(H.18\)](#):

$$x = 0,78 \left(\frac{D_a (s - c)}{2} \right)^{0,5} \quad (\text{H.18})$$

H.3.1.2.3 Where a stiffening ring consists of a closed section having two webs attached to the shell, the shell plate between the webs shall be included up to the limit of twice the value of x as defined in [H.3.1.2.2](#). The flange of the section, if not a standard structural shape, is subject to the same limitation, with x based on D_a and s of the shell. The closed section between the ring and shell shall be provided with means to equalize pressure to the space occupied by the ring.

H.3.1.2.4 Portions of the shell plate shall not be considered as contributing area to more than one stiffening ring or parts (webs) of one stiffening ring. If the stiffeners or webs of stiffeners should be so located that the maximum permissible effective shell sections overlap on either or both sides of a stiffener or web, the effective shell section for that stiffener or web shall be shortened by one-half of each overlap.

H.3.1.2.5 Length of the attachment weld segments shall not be less than 50 mm and shall have a maximum clear spacing between toes of adjacent weld segments of $8s$ for external rings and $12s$ for internal rings.

The number of intermittent attachment welds on each ring shall be at least $2n$ where n , the number of buckling lobes, is given by [Formula \(H.19\)](#):

$$n = 1,63 \left(\frac{D_a^3}{l_b 2(s - c)} \right)^{0,25} \quad (\text{H.19})$$

The size of the fillet weld leg shall be not less than the smallest of the following:

- 6 mm;

- shell thickness, s ;
- web thickness of the stiffener ring, b .

H.3.2 Dished ends and spherical shells

The calculated pressure, p_c , shall not be less than the external design pressure.

For elastic buckling, [Formula \(H.20\)](#) applies:

$$\rho_e = 1,25E \left(\frac{s}{R} \right)^2 \quad (\text{H.20})$$

For plastic deformation, [Formula \(H.21\)](#) applies:

$$p_p = \frac{20K_{20}(s-c)}{S_p(R+s)} \quad (\text{H.21})$$

p_p shall be higher than p_e obtained for elastic buckling using [Formula \(H.20\)](#).

For ellipsoidal ends, $(R + s)$ may be taken as $B_0 D_a$, where B_0 is obtained from [Table H.1](#).

Table H.1 — Values of spherical radius factor B_0 for ellipsoidal end with pressure on convex side

$\frac{D_a}{2h_o}$	3,0	2,8	2,6	2,4	2,2	2,0	1,8	1,6	1,4	1,2	1,0
B_0	1,36	1,27	1,18	1,08	0,99	0,90	0,81	0,73	0,65	0,57	0,50

Interpolation is permitted for intermediate values.

Annex I (informative)

Design of openings in cylinders, spheres and cones — Calculation

I.1 General

This annex gives two calculation methods which are equally recognized and which give comparable results.

I.2 Method 1

Where the material property K of the reinforcement is lower than that of the shell, the cross-section of pad reinforcement and the thickness of nozzle reinforcement shall be reduced by the ratio of K values before determining the factor η_A . In the case of a shell subjected only to internal pressure, with a row of nozzles joined to the shell by fully penetrating welds, it is not necessary to calculate the individual reinforcement required for each nozzle. However, the thickness of the shell to resist internal pressure shall be calculated using the least value of weakening factor of either η_A obtained from [Formula \(I.10\)](#) or η .

Openings shall also be reinforced according to [Formula \(I.1\)](#):

$$\frac{\rho}{10} \left(\frac{A \rho}{A \sigma} + \frac{1}{2} \right) \leq \frac{K}{S} \quad (I.1)$$

which is based on equilibrium between the pressurized area, A_p , and the load-bearing cross-sectional area, A_σ . The wall thickness obtained from this relationship shall be not less than the thickness of the unpierced shell.

The pressurized area, A_p , and the load-bearing cross-sectional area A_σ which equals $A_{\sigma_0} + A_{\sigma_1} + A_{\sigma_2}$ are obtained from [Figures I.1](#) to [I.5](#).

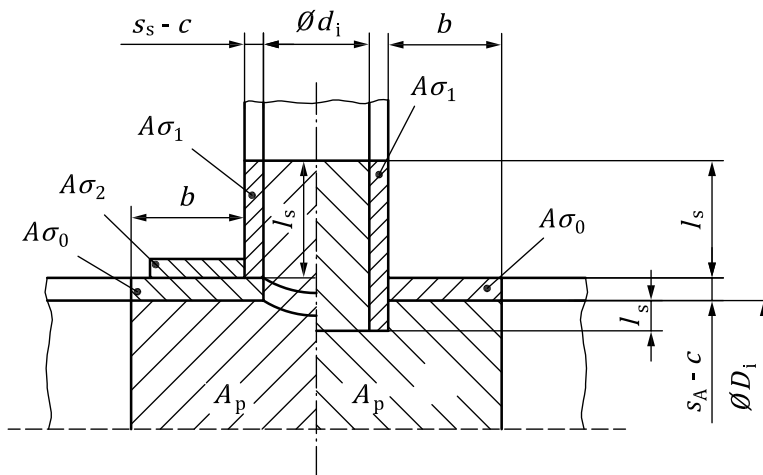

Figure I.1 — Calculation scheme for cylindrical shells

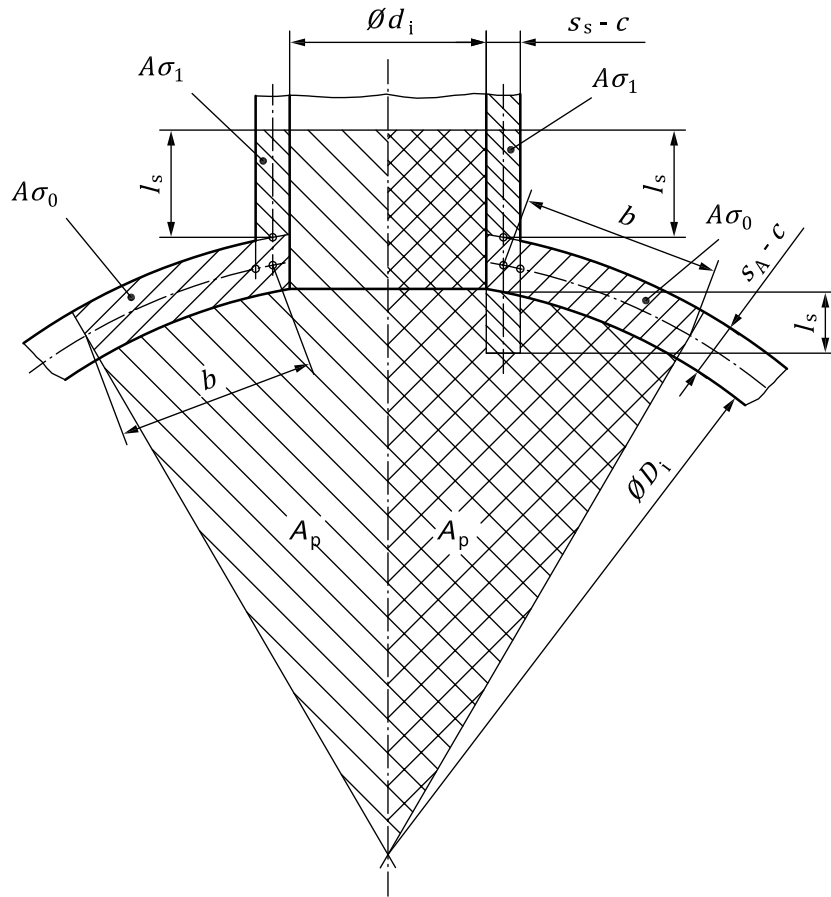

Figure I.2 — Calculation scheme for spherical shells

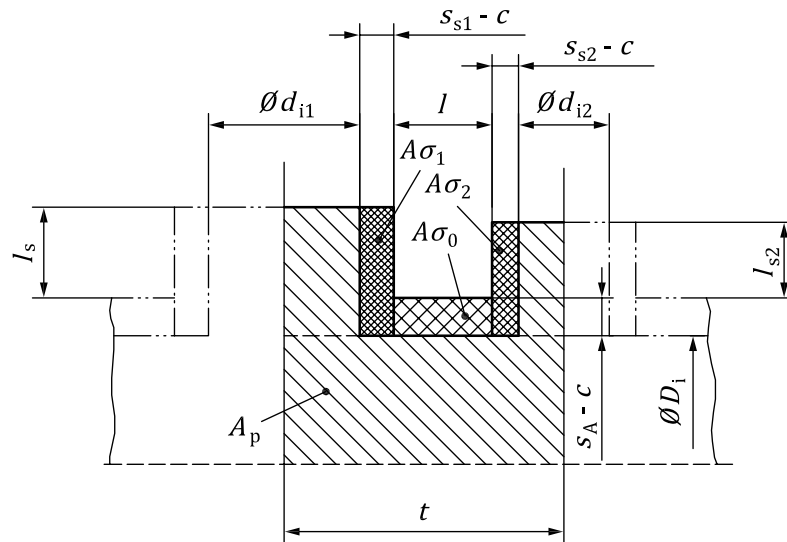

Figure I.3 — Calculation scheme for adjacent nozzles in a sphere or in a longitudinal direction of a cylinder

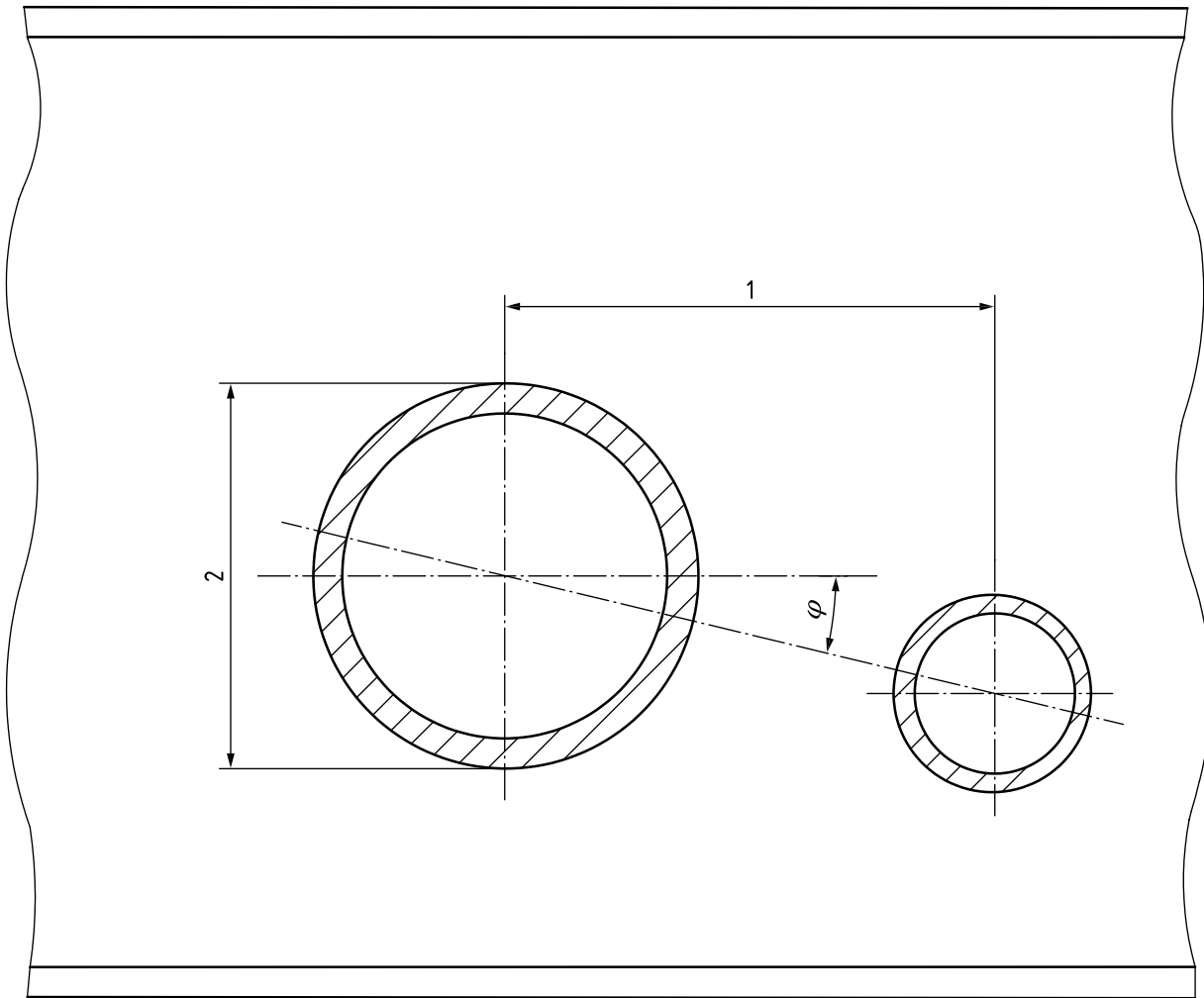

Figure I.4 — Openings between longitudinal and circumferential direction

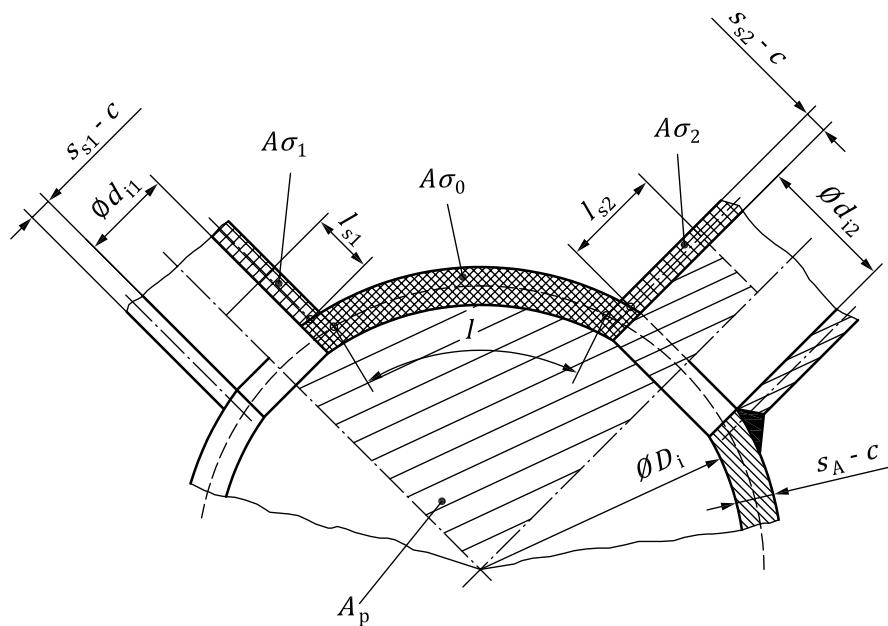

Figure I.5 — Calculation scheme for adjacent nozzles in a sphere or in a circumferential direction of a cylinder

The maximum extent of the load-bearing cross-sectional area shall be not more than b as defined in [Formula \(I.5\)](#) for shells and l_s as defined in [Formulae \(I.7\)](#) or [\(I.8\)](#) for nozzles, as appropriate.

The protrusion of nozzles l_s may be included as load-bearing cross-sectional area up to a maximum length $l's$ as given in [Formula \(I.2\)](#):

$$l's' = 0,5 l_s \quad (I.2)$$

The restrictions given shall be observed.

If the material property K_1 , K_2 , etc. of the reinforcing material is lower than that of the shell the dimensions shall conform to [Formula \(I.3\)](#):

$$\left(\frac{K}{S} - \frac{\rho}{20}\right)A_{\sigma 0} + \left(\frac{K_1}{S} - \frac{\rho}{20}\right)A_{\sigma 1} + \left(\frac{K_2}{S} - \frac{\sigma}{20}\right)A_{\sigma 2} \geq \frac{\rho}{10} A_{\rho} \quad (I.3)$$

I.3 Method 2

The symbols used in this paragraph are defined as follows.

Subscript n refers to nozzle and v refers to vessel.

A_r	total cross-sectional area of reinforcement required in the plane under consideration, in mm ² (see Figure I.6) [includes consideration of nozzle area through shell if $\frac{K_{20n}}{K_{20v}} < 1,0$];
A_1	area in excess thickness in the vessel wall available for reinforcement, in mm ² (see Figure I.6) [includes consideration of nozzle area through shell if $\frac{K_{20n}}{K_{20v}} < 1,0$];
A_2	area in excess thickness in the nozzle wall available for reinforcement, in mm ² (see Figure I.6);
A_3	area available for reinforcement when the nozzle extends inside vessel wall, in mm ² (see Figure I.6);
A_{41}, A_{42}, A_{43}	cross-sectional area of various welds available for reinforcement, in mm ² (see Figure I.6);
A_5	elongation as defined in 11.3.1 ;
A_6	cross-sectional area of material added as reinforcement, in mm ² (see Figure I.6);
c	corrosion allowance, in mm;
D_p	outside diameter of reinforcing element, in mm (actual size of reinforcing element may exceed the limits of reinforcement; however, credit cannot be taken for any material outside these limits);
d	finished diameter of circular opening or finished dimension (chord length at mid-surface of thickness excluding excess thickness available for reinforcement) of non-radial opening in the plane under consideration, in mm (see Figure I.6);
η	1 (see definitions for s_r and s_n);
η_1	1, when an opening is in the solid plate or in a full penetration butt joint; or joint efficiency when any part of the opening passes through any other welded joint;

h_i	distance nozzle projects beyond the inner surface of the vessel wall, in mm. Extension of the nozzle beyond the inside surface of the vessel wall is not limited; however, for reinforcement calculations, credit shall not be taken for material outside the limits of reinforcement;
R_n	inside radius of the nozzle under consideration, in mm;
$\frac{K_{20}}{S}$	allowable stress value in tension, in N/mm ² ;
$\frac{K_{20n}}{S}$	allowable stress in nozzle, in N/mm ² ;
$\frac{K_{20v}}{S}$	allowable stress in vessel, in N/mm ² ;
$\frac{K_{20p}}{S}$	allowable stress in reinforcing element, in N/mm ² ;
f_r	strength-reduction factor, not greater than 1,0;
f_{r1}	$\frac{K_{20n}}{K_{20v}}$ for nozzle wall inserted through the vessel wall;
f_{r1}	1,0 for nozzle wall abutting the vessel wall;
f_{r2}	$\frac{K_{20n}}{K_{20v}}$
f_{r3}	lesser of K_{20n} or K_{20p}/K_{20v} ;
f_{r4}	K_{20p}/K_{20v} ;
s	specified vessel wall thickness in the corroded condition (not including forming allowances), in mm (for pipe it is the nominal thickness less manufacturing under-tolerance allowed in the pipe specification);
s_p	thickness or height of reinforcing element, in mm;
s_i	nominal thickness of internal projection of nozzle wall, in mm;
s_r	required thickness, in mm, of a seamless shell based on the circumferential stress, or of a formed end, for the designated pressure using $\eta = 1$.

Reinforcement shall be provided in amount and distribution such that the area requirements for reinforcement are satisfied for all planes through the centre of the opening and normal to the vessel surface. For a circular opening in a cylindrical shell, the plane containing the axis of the shell is the plane of greatest loading due to pressure. Not less than half the required reinforcement shall be on each side of the centre line of single openings.

The total cross-sectional area of reinforcement, A_r , required in any given plane through the opening for a shell or dished end under internal pressure shall not be less than [Formula \(I.4\)](#):

$$A_r = ds_r + 2s_n s_r (1 - f_{r1}) \quad (I.4)$$

The reinforcement required for openings in vessels under external pressure need be only 50 % of that required per [Formula \(I.4\)](#).

When two openings are spaced so that their limits of reinforcement overlap, the two openings shall be reinforced in the plane connecting the centres with a combined reinforcement that has an area not less than the sum of the areas required for each opening. No portion of the cross-section is to be considered as applying to more than one opening, nor to be considered more than once in a combined area.

The limits of reinforcement and the details of calculations for the reinforcement area to be provided are shown in [Figure I.6](#).

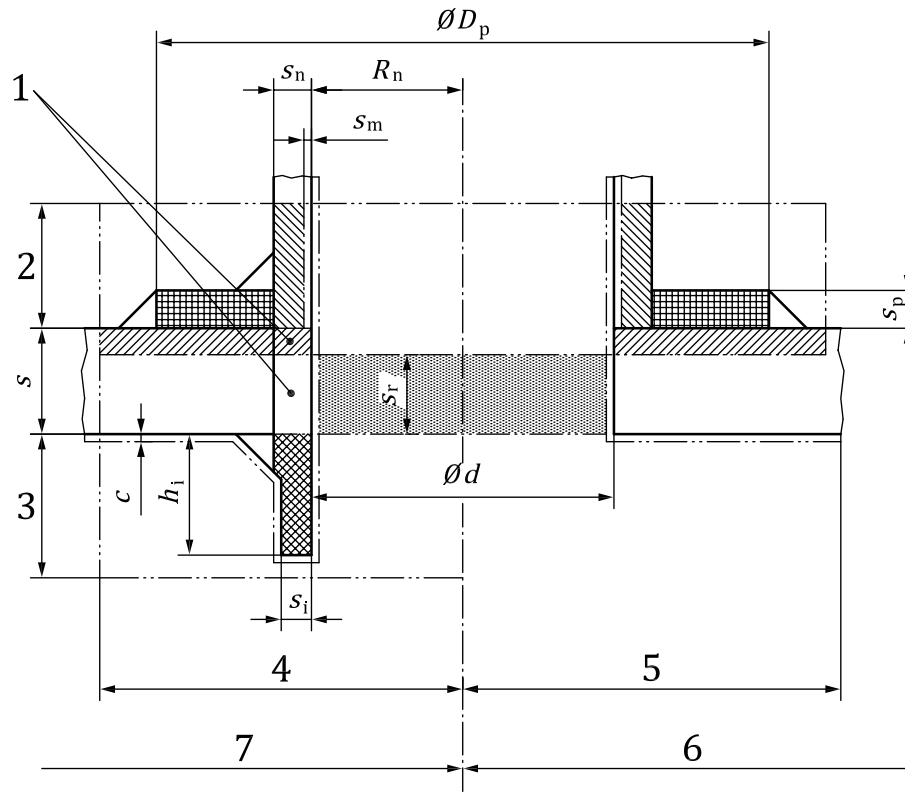

Key

- 1 includes consideration of areas if $K_{20n}/K_{20v} < 1,0$ (both sides of C_L)
- 2 $0,78\sqrt{R_n s_n}$
- 3 $0,78\sqrt{R_n s_i}, h_i$ use smaller value
- 4 d or $R_n + s_n + s$ use larger value
- 5 d or $R_n + s_n + s$ use larger value
- 6 for nozzle wall abutting the vessel wall
- 7 for nozzle wall inserted through the vessel wall

Without reinforcing element:

$$\text{[Pattern]} = A_r = ds_r + 2s_n s_r (1 - f_{r1})$$

Area required

$$\begin{aligned} \text{[Pattern]} &= A_1 = d(v_1 s - s_r) - 2s_n(v_1 s - s_r)(1 - f_{r1}) \\ &= 2(s + s_n)(v_1 s - s_r) - 2s_n(v_1 s - s_r)(1 - f_{r1}) \end{aligned}$$

Area available in shell; use larger value

$$\text{[Pattern]} = A_2 = 1,56\sqrt{R_n s_n (s_n - s_m)^2} f_{r2}$$

Area available in nozzle projecting outward

Without reinforcing element:

$$\begin{aligned} \text{[Cross-hatched rectangle]} &= A_3 = 1,56 \sqrt{R_n s_i^3} f_{r2} \\ &= 2h_1 s_i f_{r2} \end{aligned}$$

$$\text{[Two triangles pointing outwards]} = A_{41} = \text{outward nozzle weld} = (\text{leg})^2 f_{r2}$$

$$\begin{aligned} \text{[Two triangles pointing inwards]} &= A_{43} = \text{inward nozzle weld} = (\text{leg})^2 f_{r2} \\ \text{if } A_1 + A_2 + A_3 + A_{41} + A_{43} &> A_r \\ \text{if } A_1 + A_2 + A_3 + A_{41} + A_{43} &< A_r \end{aligned}$$

Area available in inward nozzle; use smaller value

Area available in outward weld

Area available in inward weld

Opening is adequately reinforced

Opening is not adequately reinforced so reinforcing elements shall be added and/or thicknesses shall be increased

With reinforcing element added:

A_r = same as A_r above

A_1 = same as A_1 above

A_2 = same as A_2 above

A_3 = same as A_3 above

$$\text{[Two triangles pointing outwards]} = A_{41} = \text{outward nozzle weld} = (\text{leg})^2 f_{r3}$$

$$\text{[Two triangles pointing outwards]} = A_{42} = \text{outer element weld} = (\text{leg})^2 f_{r4}$$

$$\text{[Two triangles pointing inwards]} = A_{43} = \text{inward nozzle weld} = (\text{leg})^2 f_{r2}$$

$$\begin{aligned} \text{[Grid pattern]} &= A_5 = (D_p - d - 2s_n) s_p f_{r4} \\ \text{if } A_1 + A_2 + A_3 + A_{41} + A_{42} + A_{43} + A_5 &> A_r \end{aligned}$$

Area required

Area available

Area available in nozzle projecting outward

Area available in inward weld

Area available in outward weld

Area available in outer weld

Area available in inward weld

Area available in element

Opening is adequately reinforced

Figure I.6 — Nomenclature and formulas for reinforced openings Ring or pad reinforcement or increased shell thickness

If the actual wall thickness of the cylinder or sphere is less than the required thickness s_A at the opening, the opening is adequately reinforced if the wall thickness s_A is available around the opening over a width given in [Formula \(I.5\)](#):

$$b = \sqrt{(D_i + s_A - c)(s_A - c)} \tag{I.5}$$

with a minimum of $3s_A$ (see [Figure I.7](#)).

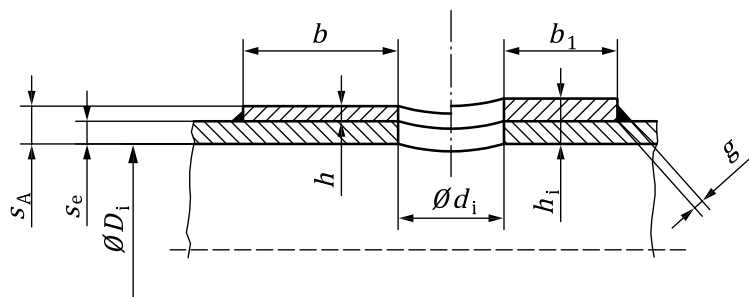

Figure I.7 — Pad reinforcement

For calculation purposes, s_A shall be limited to not more than twice the actual wall thickness.

The thickness of pad reinforcement in accordance with [Figure I.7](#) should be not more than the actual wall thickness to which the pad is attached.

Internal pad reinforcement is not allowed.

The width of the pad reinforcement may be reduced to b_1 , provided the pad thickness is increased to h_1 , according to [Formula \(I.6\)](#):

$$b_1 \times h_1 \geq b \times h \quad (\text{I.6})$$

and the limits given above are observed.

I.4 Reinforcement by increased nozzle thickness

I.4.1 General

The thickness of the nozzle, s_N , should be not greater than $2 \times s_A$.

The wall thickness, s_A , at the opening shall extend over a width b in accordance with [Formula \(I.5\)](#) with a minimum of $3s_A$.

The limits of reinforcement normal to the vessel wall are:

— for cylinders and cones:

$$l_s = 125 \sqrt{(d_i + s_s - c)(s_s - c)} \quad (\text{I.7})$$

— for spheres:

$$l_s = \sqrt{(d_i + s_s - c)(s_s - c)} \quad (\text{I.8})$$

The length l_s may be reduced to l_{s1} , provided that the thickness s_s is increased to s_{s1} , according to [Formula \(I.8\)](#), and the limits given above are observed.

$$l_{s1} \times s_{s1} \geq l_s \times s_s \quad (\text{I.8})$$

I.4.2 Reinforcement by a combination of increased shell and nozzle thicknesses

Shell and nozzle thicknesses may be increased in combination for the reinforcement of openings.

For the calculation of reinforcement, [Figures I.2](#) and [I.3](#) shall be applied together. The increase in shell thickness may be achieved by an actual increase in shell thickness or the addition of a pad.

I.4.3 Multiple openings

Multiple openings are regarded as single openings, provided the distance l between two adjacent openings, [Figures I.3](#) and [I.5](#), complies with [Formula \(I.9\)](#):

$$l \geq 2\sqrt{(D_i + s_A - c)(s_A - c)} \quad (I.9)$$

If l is less than required by [Formula \(I.9\)](#), a check shall be made to determine whether the cross-section between openings is able to withstand the load acting on it. Adequate reinforcement is available if the requirement of [Formula \(I.1\)](#) or [\(I.3\)](#), as appropriate, is met.

Where adjacent openings in a cylinder are arranged intermediately between the longitudinal and circumferential direction, the calculation scheme for the longitudinal direction ([Figure I.3](#)) shall be

applied, but the part of the pressure-loaded area corresponding to the unpierced cylinder $\left(\frac{tD_i}{2}\right)$ may

be reduced with an arrangement factor $0,5(1 + \cos^2 \varphi)$.

See [Figure I.4](#) for angle φ .

Nozzles joined to the shell in line by full-penetration welds with the wall thickness calculated for internal pressure only may be designed with a weakening factor:

$$\eta_A = \frac{(t - d_i)}{2} \quad (I.10)$$

If the nozzles are not attached by full-penetration welds, D_a shall be used in [Formula \(I.10\)](#).

Annex J (normative)

Reference material & equivalent thickness

J.1 General

The equivalent thickness shall be calculated using Method A or Method B, depending on how the minimum thickness is specified. If the value of ν is not specified, use $\nu = 0.3$.

J.2 Method A

The required minimum equivalent thickness shall be calculated with [Formula \(J.1\)](#):

$$S_1 = \frac{1300S_r}{\sqrt[3]{P_{m1}R_{m1}A_1}} \quad (\text{J.1})$$

where

- A_1 is the specified minimum elongation at 20 °C at fracture of the material to be used, in accordance with the applicable national or international standard, in %;
- E_1 is the modulus of elasticity of the actual material at 20 °C to be used, in MPa;
- S_1 is the required minimum thickness of the actual material to be used, in mm;
- S_r is the minimum required thickness of the Reference Material specified, in mm;
- P_{m1} is $E_1(1/\nu_1)^2 / [(1/\nu_1)^2 - 1]$
- R_{m1} is the specified minimum tensile strength at 20 °C of the actual material to be used, MPa. Where a minimum is specified for tensile strength in specifications, the actual value indicated in the material test results may be used up to 15 % higher than specified minimum;
- ν_1 is the Poisson's ratio of the actual material to be used.

The thicknesses of S_r and S , shall be exclusive of any allowances for chemical or physical actions that can influence the thicknesses, e.g., corrosion, erosion and forming (thinning).

For hazardous materials tanks for which a minimum reference material thickness of 8 mm (0,315 in) or higher is specified, the required thickness is based on a shell diameter of 1,8 m. When the shell has a diameter of more than 1,8 m, the equivalent minimum thickness obtained from the conversion formulae shall be multiplied by $d_1/1,8$, where d_1 is the actual diameter of the shell in meters but not less than 1,8 m, to obtain the minimum required thickness.

J.2.1 Example 1

Specified minimum thickness is 6 mm in reference material, which is the required thickness for an austenitic stainless steel material with the following material properties:

- $R_{m1} = 515$ MPa;
- $A_1 = 40$ %;
- $E_1 = 190\,344,8$ MPa;

— $v_1 = 0,305$;

— $S_r = 6$ mm;

—
$$P_{m1} = \frac{190\,344,8 \left(\frac{1}{0,305} \right)^2}{\left(\frac{1}{0,305} \right)^{-1}} = 209\,868 \text{ MPa}.$$

J.2.2 Example 2

Specified minimum thickness is 3 mm in reference material ($S_r = 3$ mm), which is the required minimum thickness for an aluminium alloy with temper T6, and temper T0:

— $R_{m1} = 290$ MPa (42,000 psi) and $A_1 = 35$ % if the material is heat treated to T6 temper.

— $R_{m1} = 207$ MPa and $A_1 = 16\%$, which are the values for 0 temper of the same material.

— $E_1 = 68\,965,5$ MPa and $v_1 = 0.332$.

For a welded vessel heat treated to T6 temper, [Formulae \(J.2\)](#) and [\(J.3\)](#) apply:

$$P_{m1} = \frac{68\,965,5 \left(\frac{1}{0,332} \right)^2}{\left(\frac{1}{0,332} \right)^{-1}} = 77\,509 \text{ MPa} \quad (\text{J.2})$$

$$S_1 = \frac{1\,300(3)}{\sqrt[3]{(77\,509)(290)(35)}} = 4,22 \text{ mm} \quad (\text{J.3})$$

For a welded vessel made with the same material, but 0 temper (T0), [Formula \(J.4\)](#) applies:

$$S_1 = \frac{1\,300(3)}{\sqrt[3]{(77\,509)(207)(16)}} = 6,14 \text{ mm} \quad (\text{J.4})$$

J.3 Method B: Equivalent thickness

Where a material and its minimum required thickness are specified, the minimum required thickness of any other material shall be calculated according to [Formula \(J.5\)](#):

$$S_1 = S_s \left(\frac{P_{ms} R_{ms} A_s}{P_{m1} R_{m1} A_1} \right)^{\frac{1}{3}} \quad (\text{J.5})$$

where

A_1 is the specified minimum elongation at 20 °C at fracture of the material to be used, in accordance with the applicable national or international standard, in %;

A_s is the specified minimum elongation at 20 °C at fracture of the specified material, in accordance with the applicable national or international standard, in %;

E_1 is the modulus of elasticity of the material to be used, in MPa at 20 °C;

E_s is the modulus of elasticity of specified material, in MPa at 20 °C;

- S_1 is the required minimum thickness of the actual material to be used, in mm;
- S_s is the minimum required thickness of the specified material, in mm;
- P_{m1} is $E_1(1/\nu_1)^2 / [(1/\nu_1)^2 - 1]$;
- P_{ms} is $E_s(1/\nu_s)^2 / [(1/\nu_s)^2 - 1]$;
- R_{m1} is the specified minimum tensile strength at 20 °C of the actual material to be used, in accordance with the applicable national or international standard, MPa. Where a minimum is specified for tensile strength in specifications, the actual value indicated in the material test results may be used up to 15 % higher than specified minimum;
- R_{ms} is the specified minimum tensile strength at 20 °C of the specified material, in accordance with the applicable national or international standard, in MPa;
- ν_1 is the Poisson's ratio of the actual material to be used;
- ν_s is the Poisson's ratio of the specified material.

The thicknesses of S_s and S_1 shall be exclusive of any allowances for chemical or physical actions that can influence the thicknesses, e.g., corrosion, erosion, and forming (thinning).

Values of R_m (tensile strength) and A (elongation at fracture, %) at a temperature not lower than the saturation temperature of the fluid at pressure P_s , according to national or international standards may be used in [Formulae \(J.1\)](#) or [\(J.5\)](#), provided the values of R_m and A used are at the same temperature.

Annex K (normative)

Refrigerated liquefied gases

Table K.1 — Refrigerated but non-toxic gases

Classification code	Identification number, name and description ^a	
3 °A	Asphyxiant gases	
	1913	Neon, refrigerated liquid
	1951	Argon, refrigerated liquid
	1963	Helium, refrigerated liquid
	1970	Krypton, refrigerated liquid
	1977	Nitrogen, refrigerated liquid
	2187	Carbon dioxide, refrigerated liquid
	2591	Xenon, refrigerated liquid
	3136	Trifluoromethane refrigerated liquid
3158	Gas, refrigerated liquid, N.O.S. (not otherwise specified)	
3 °O	Oxidizing gases	
	1003	Air, refrigerated liquid
	1073	Oxygen, refrigerated liquid
	2201	Nitrous oxide, refrigerated liquid, oxidizing
3311	Gas, refrigerated liquid, oxidizing, N.O.S.	
3 °F	Flammable gases	
	1038	Ethylene, refrigerated liquid
	1961	Ethane, refrigerated liquid
	1966	Hydrogen, refrigerated liquid
	1972	Methane, refrigerated liquid or natural gas, refrigerated liquid, with high methane content
	3138	Ethylene, acetylene and propylene mixture, refrigerated liquid, containing at least 71,5 % ethylene with not more than 22,5 % acetylene and not more than 6 % propylene
3312	Gas, refrigerated liquid, flammable, N.O.S.	
^a Classification codes, identification number, name and description according to the UN Model Regulations ^[1] .		

Bibliography

- [1] United Nations, Recommendations on the Transport of Dangerous Goods — Model Regulations
- [2] ISO 3452-1, *Non-destructive testing — Penetrant testing — Part 1: General principles*
- [3] ISO 4136, *Destructive tests on welds in metallic materials — Transverse tensile test*
- [4] ISO 5173, *Destructive tests on welds in metallic materials — Bend tests*
- [5] ISO 6520-1, *Welding and allied processes — Classification of geometric imperfections in metallic materials — Part 1: Fusion welding*
- [6] ISO 9016, *Destructive tests on welds in metallic materials — Impact tests — Test specimen location, notch orientation and examination*
- [7] ISO 9328-4, *Steel flat products for pressure purposes — Technical delivery conditions — Part 4: Nickel-alloy steels with specified low temperature properties*
- [8] ISO 9328-7, *Steel flat products for pressure purposes — Technical delivery conditions — Part 7: Stainless steels*
- [9] ISO 10675-2, *Non-destructive testing of welds — Acceptance levels for radiographic testing — Part 2: Aluminium and its alloys*
- [10] ISO 13985, *Liquid hydrogen — Land vehicle fuel tanks*
- [11] ISO 15607, *Specification and qualification of welding procedures for metallic materials — General rules*
- [12] ISO 15156-3, *Petroleum and natural gas industries — Materials for use in H₂S-containing environments in oil and gas production — Part 3: Cracking-resistant CRAs (corrosion-resistant alloys) and other alloys*
- [13] ISO 15614-3, *Specification and qualification of welding procedures for metallic materials — Welding procedure test — Part 3: Fusion welding of non-alloyed and low-alloyed cast irons*
- [14] ISO 17636 (all parts), *Non-destructive testing of welds — Radiographic testing*
- [15] ISO 17945, *Petroleum, petrochemical and natural gas industries — Metallic materials resistant to sulfide stress cracking in corrosive petroleum refining environments*
- [16] ISO 21013-1, *Cryogenic vessels — Pressure-relief accessories for cryogenic service — Part 1: Reclosable pressure-relief valves*
- [17] ISO 21013-2, *Cryogenic vessels — Pressure-relief accessories for cryogenic service — Part 2: Non-reclosable pressure-relief devices*
- [18] ISO 23277, *Non-destructive testing of welds — Penetrant testing — Acceptance levels*
- [19] EN 1708-1, *Welding — Basic welded joint details in steel — Part 1: Pressurized components*
- [20] EN 10028-4, *Flat products made of steels for pressure purposes — Part 4: Nickel alloy steels with specified low temperature properties*
- [21] EN 10028-7, *Flat products made of steels for pressure purposes — Part 7: Stainless Steels*
- [22] EN 13445-4, *Unfired pressure vessels — Part 4: Fabrication*
- [23] ASME Section XII, Rules for Construction and Continued Service of Transport Tanks

Bureau of Indian Standards

BIS is a statutory institution established under the *Bureau of Indian Standards Act, 2016* to promote harmonious development of the activities of standardization, marking and quality certification of goods and attending to connected matters in the country.

Copyright

BIS has the copyright of all its publications. No part of these publications may be reproduced in any form without the prior permission in writing of BIS. This does not preclude the free use, in the course of implementing the standard, of necessary details, such as symbols and sizes, type or grade designations. Enquiries relating to copyright be addressed to the Head (Publication & Sales), BIS.

Review of Indian Standards

Amendments are issued to standards as the need arises on the basis of comments. Standards are also reviewed periodically; a standard along with amendments is reaffirmed when such review indicates that no changes are needed; if the review indicates that changes are needed, it is taken up for revision. Users of Indian Standards should ascertain that they are in possession of the latest amendments or edition by referring to the website-www.bis.gov.in or www.standardsbis.in.

This Indian Standard has been developed from Doc No.: MED 16 (25890).

Amendments Issued Since Publication

Amend No.	Date of Issue	Text Affected

BUREAU OF INDIAN STANDARDS

Headquarters:

Manak Bhavan, 9 Bahadur Shah Zafar Marg, New Delhi 110002

Telephones: 2323 0131, 2323 3375, 2323 9402

Website: www.bis.gov.in

Regional Offices:

Central : 601/A, Konnectus Tower -1, 6th Floor,
DMRC Building, Bhavbhuti Marg, New
Delhi 110002

Telephones

{ 2323 7617

Eastern : 8th Floor, Plot No 7/7 & 7/8, CP Block, Sector V,
Salt Lake, Kolkata, West Bengal 700091

{ 2367 0012
{ 2320 9474

Northern : Plot No. 4-A, Sector 27-B, Madhya Marg,
Chandigarh 160019

{ 265 9930

Southern : C.I.T. Campus, IV Cross Road, Taramani, Chennai 600113

{ 2254 1442
{ 2254 1216

Western : 5th Floor/MTNL CETTM, Technology Street, Hiranandani Gardens,
Powai, Mumbai 400076

{ 2570 0030
{ 2570 2715

Branches : AHMEDABAD, BENGALURU, BHOPAL, BHUBANESHWAR, CHANDIGARH, CHENNAI, COIMBATORE, DEHRADUN, DELHI, FARIDABAD, GHAZIABAD, GUWAHATI, HARYANA (CHANDIGARH), HUBLI, HYDERABAD, JAIPUR, JAMMU, JAMSHEDPUR, KOCHI, KOLKATA, LUCKNOW, MADURAI, MUMBAI, NAGPUR, NOIDA, PARWANOO, PATNA, PUNE, RAIPUR, RAJKOT, SURAT, VIJAYAWADA.