

---

---

प्रक्रिया प्रवाह आरेख, पाइपिंग और  
मापयन्त्रण आरेख हेतु आलेखीय प्रतीकों पर  
अनुशंसा

( तीसरा पुनरीक्षण )

**Recommendations on Graphical  
Symbols for Process Flow Diagrams,  
Piping and Instrumentation  
Diagrams**

( *Third Revision* )

ICS 01.080.30; 23.040.01

© BIS 2023



भारतीय मानक ब्यूरो  
BUREAU OF INDIAN STANDARDS  
मानक भवन, 9 बहादुर शाह ज़फर मार्ग, नई दिल्ली - 110002  
MANAK BHAVAN, 9 BAHADUR SHAH ZAFAR MARG  
NEW DELHI - 110002  
[www.bis.gov.in](http://www.bis.gov.in) [www.standardsbis.in](http://www.standardsbis.in)

## FOREWORD

This Indian Standard (Third Revision) was adopted by the Bureau of Indian Standards, after the draft finalized by the Chemical Engineering Plants and Related Equipment Sectional Committee had been approved by the Mechanical Engineering Divisional Council.

Process flow diagrams are widely used in chemical industry as an aid to show basic items of major equipments and their relations to one another in the process scheme. The important flow lines are indicated as connecting items of equipments and help to describe how the process operates.

Piping and instrumentation diagrams are used in the chemical industry to indicate all important aspects such as:

- a) All equipment items;
- b) All instrument items;
- c) All pipelines; and
- d) Important aspects such as insulations, slopes, equipment elevations, etc.

This standard was first published in 1965 and then revised in 1976 and 1999. The present revision has been taken up with a view to incorporate the modification found necessary as a result of experience gained in the use of this standard. Also, in this revision, the standard has been brought into the latest style and format of Indian Standards, and references to Indian Standards, wherever applicable have been updated. In this revision, the following major changes have been made.

The composition of the Committee responsible for the formulation of this standard is given in Annex A.

For the purpose of deciding whether a particular requirement of this standard is complied with the final value, observed or calculated, expressing the result of a test or analysis, shall be rounded off in accordance with IS 2 : 2022 'Rules for rounding off numerical values (*second revision*)'. The number of significant places retained in the rounded off value should be the same as that of the specified value in this standard.

*Indian Standard*

# RECOMMENDATIONS ON GRAPHICAL SYMBOLS FOR PROCESS FLOW DIAGRAMS, PIPING AND INSTRUMENTATION DIAGRAMS

*( Third Revision )***1 SCOPE**

This standard lays down symbols that are to be used while preparing process flow diagrams as well as piping and instrumentation diagrams in order to represent the major requirements of plant or units in the chemical industry.

**2 SYMBOLS**

**2.1** The symbols indicated here represent only major items of plants. Two or more of the basic symbols may be combined to represent composite units.

**2.2** Requirement of symbols has been covered in the following Sections:

Section 01 General

Section 02 Process quantities

Section 03 Piping

Section 04 Valves

Section 05 Fittings

Section 06 Instruments

Section 07 Pumps

Section 08 Compressors

Section 09 Heating and cooling arrangements

Section 10 Furnaces and boilers

Section 11 Process vessels

Section 12 Storage vessels/tanks

Section 13 Dryer

Section 14 Size reduction equipment

Section 15 Separators

Section 16 Filters

Section 17 Centrifuges

Section 18 Stirrers

Section 19 Mixers

Section 20 Feeders

Section 21 Conveyors

Section 22 Transport vehicle

Section 23 Miscellaneous

Section 24 Service fluid codes

Section 25 Insulation/tracings types

**SECTION 01 GENERAL**

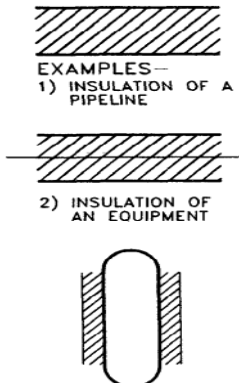
<i>Sl No.</i>	<i>Symbol No.</i>	<i>Description</i>	<i>Symbols</i>	<i>Remarks</i>
(1)	(2)	(3)	(4)	(5)
i)	0101	Insulation or Tracing	 <p>EXAMPLES— 1) INSULATION OF A PIPELINE 2) INSULATION OF AN EQUIPMENT</p>	<p>Insulation or tracing for equipment and lines are generally not shown symbolically in PFD'S and P &amp; ID'S.</p> <p>In P&amp;ID'S, the letters indicating the type of insulation or tracing are placed on top of the line with or without line number.</p>

**SECTION 02 PROCESS QUANTITIES**

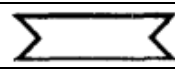
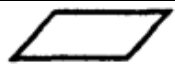
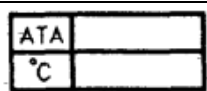
<i>Sl No.</i>	<i>Symbol No.</i>	<i>Description</i>	<i>Symbols</i>	<i>Remarks</i>
(1)	(2)	(3)	(4)	(5)
i)	0201	Liquid flow		Place numerical quantities specified within the symbol
ii)	0202	Gas flow		
iii)	0203	Pressure and temperature		

**SECTION 03 PIPING**



<i>Sl No.</i>	<i>Symbol No.</i>	<i>Description</i>	<i>Symbols</i>	<i>Remarks</i>
(1)	(2)	(3)	(4)	(5)
i)	0301	Inflow line		Identify by name
ii)	0302	Outflow line		Identify by name
iii)	0303	Connecting line		
iv)	0304	Cross over line		
v)	0305	Direction of process flow		
vi)	0306	Slope of a process line		Indicates direction but not limits. Degrees are to be shown separately

Table (Concluded)

<i>Sl No.</i>	<i>Symbol No.</i>	<i>Description</i>	<i>Symbols</i>	<i>Remarks</i>
(1)	(2)	(3)	(4)	(5)
vii)	0307	Dead end		
viii)	0308	Buried line		
ix)	0309	Vendor limit line		
x)	0310	Tracing		Form of heating to be indicated by initial letter
xi)	0311	Change of pipe specification		
xii)	0312	Centre line		
xiii)	0313	Coil		
xiv)	0314	Process line		
xv)	0315	Jacketed line		

## SECTION 04 VALVE

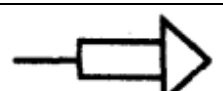
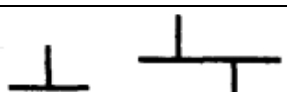
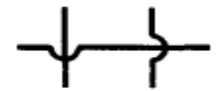
<i>Sl No.</i>	<i>Symbol No.</i>	<i>Description</i>	<i>Symbols</i>	<i>Remarks</i>
(1)	(2)	(3)	(4)	(5)
i)	0401	Gate valve		
ii)	0402	Globe valve		
iii)	0403	Check valve		
iv)	0404	Angle valve		
v)	0405	Diaphragm valve		
vi)	0406	Safety valve (pressure relief valve)		
vii)	0407	Ball valve		

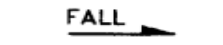
Table (Continued)











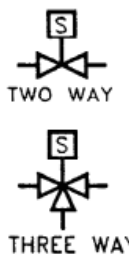

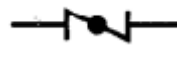

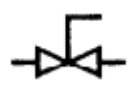

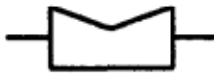

Sl No.	Symbol No.	Description	Symbols	Remarks
(1)	(2)	(3)	(4)	(5)
viii)	0408	Solenoid valve	 <p>TWO WAY</p> <p>THREE WAY</p>	
ix)	0409	Float valve		
x)	0410	Butterfly valve		
xi)	0411	Regulating globe valve		
xii)	0412	Foot valve with strainer		
xiii)	0413	Plug valve		
xiv)	0414	Control valve		
xv)	0415	Piston operated hydraulic control valve		
xvi)	0416	Electrically operated control valve		
xvii)	0417	Pinch valve		
xviii)	0418	Spring loaded valve		
xix)	0419	Control valve with hand wheel		
xx)	0420	PCV down stream		

Table (Concluded)

<i>Sl No.</i>	<i>Symbol No.</i>	<i>Description</i>	<i>Symbols</i>	<i>Remarks</i>
(1)	(2)	(3)	(4)	(5)
xxi)	0421	PCV up stream		
xxii)	0422	Hand-operated valve		
xxiii)	0423	Plunger-operated valve		
xxiv)	0424	Pilot-operated valve		
xxv)	0425	4-way valve		
xxvi)	0426	Needle valve		
xxvii)	0427	Positive choke		
xxviii)	0428	Adjustable choke		
xxix)	0429	Motor operated valve		

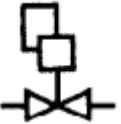
## SECTION 05 FITTINGS

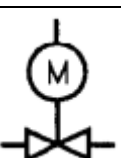

<i>Sl No.</i>	<i>Symbol No.</i>	<i>Description</i>	<i>Symbols</i>	<i>Remarks</i>
(1)	(2)	(3)	(4)	(5)
i)	0501	Expansion joint		
ii)	0502	Hose connector		
iii)	0503	Flexible hose		

Table (Continued)





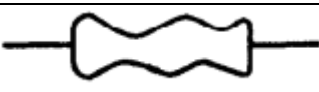



Sl No.	Symbol No.	Description	Symbols	Remarks
(1)	(2)	(3)	(4)	(5)
iv)	0504	Spectacle blind		
v)	0505	Line blind		
vi)	0506	Reducer/Expander		
vii)	0507	Blind flange		
viii)	0508	Drain funnel		
ix)	0509	Threaded cap		
x)	0510	Orifice		
xi)	0511	Venturi meter		
xii)	0512	Steam trap		
xiii)	0513	Vent with goose neck		
xiv)	0514	Sight glass		
xv)	0515	Union		
xvi)	0516	Coupling		
xvii)	0517	Adaptor		
xviii)	0518	Flow-element		

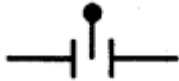
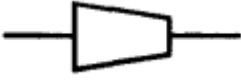

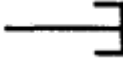
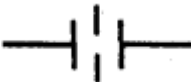
Table (Continued)

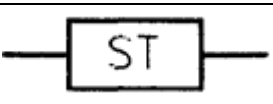

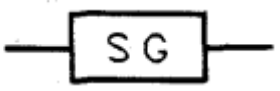
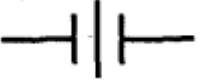

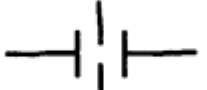





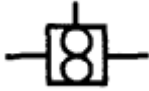
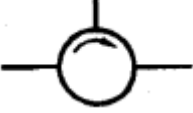
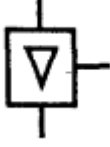
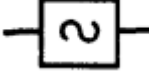

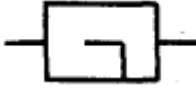

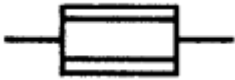
Sl No.	Symbol No.	Description	Symbols	Remarks
(1)	(2)	(3)	(4)	(5)
xix)	0519	Turbine meter		
xx)	0520	Pos. disp. meter		
xxi)	0521	Rotameter		
xxii)	0522	Sonic meter		
xxiii)	0523	Magnetic meter		
xxiv)	0524	Pitot tube		
xxv)	0525	Drain plugged		
xxvi)	0526	Drain flanged		
xxvii)	0527	Straightening vanes		
xxviii)	0528	Analyser		
xxix)	0529	Filter		
xxx)	0530	Filter		
xxxi)	0531	T-type strainer		

Table (Concluded)

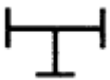
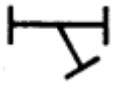
<i>Sl No.</i>	<i>Symbol No.</i>	<i>Description</i>	<i>Symbols</i>	<i>Remarks</i>
(1)	(2)	(3)	(4)	(5)
xxxii)	0532	Y-type strainer		
xxxiii)	0533	Temporary		
xxxiv)	0534	Basket strainer		
xxxv)	0535	Flame arrester		
xxxvi)	0536	Cone type strainer		
xxxvii)	0537	Sample point		
xxxviii)	0538	Pipe cap welded		

## SECTION 06 INSTRUMENTS

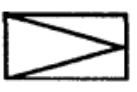
## INSTRUMENTATION SYMBOL

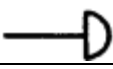



<i>Sl No.</i>	<i>Symbol No.</i>	<i>Description</i>	<i>Symbols</i>	<i>Remarks</i>
(1)	(2)	(3)	(4)	(5)
i)	0601	Instrument air signal		
ii)	0602	Instrument electric signal		
iii)	0603	Instrument supply lines		
iv)	0604	Instrument capillary tubing		
v)	0605	Hydraulic lines		
vi)	0606	Software connections		
vii)	0607	Locally mounted instruments		

Table (Continued)



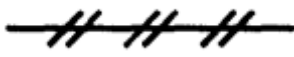

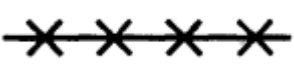
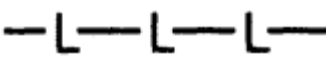
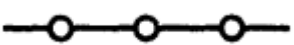















<i>Sl No.</i>	<i>Symbol No.</i>	<i>Description</i>	<i>Symbols</i>	<i>Remarks</i>
(1)	(2)	(3)	(4)	(5)
viii)	0608	Instrument mounted on main panel		
ix)	0609	Instrument mounted on local panel		
x)	0610	Transmitter locally mounted		
xi)	0611	Transmitter panel mounted		
xii)	0612	Computer		
xiii)	0613	Computer local panel		
xiv)	0614	DCS/DIDC		
xv)	0615	Gas filter		
xvi)	0616	Interlock		
xvii)	0617	Rear panel instrument		
xviii)	0618	Running light (local)		
xix)	0619	Running light (panel)		
xx)	0620	Running light (local panel)		

Table (Concluded)

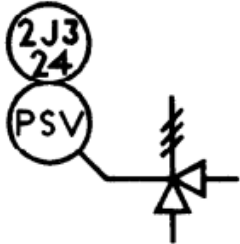
<i>Sl No.</i>	<i>Symbol No.</i>	<i>Description</i>	<i>Symbols</i>	<i>Remarks</i>
(1)	(2)	(3)	(4)	(5)
xxi)	0621	Remote telemetric unit		
xxii)	0622	Inlet size		
xxiii)	0623	Rupture disk		
xxiv)	0624	Rotameter		
xxv)	0625	Diaphragm seal		
xxvi)	0626	Breather valve		
xxvii)	0627	Programmable logic control		
xxviii)	0628	Programmable logic control on local panel		

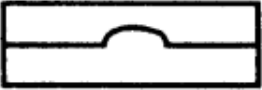
### INSTRUMENT LEGEND

(See Table 1 for definition of identification letters)

<i>Sl No.</i>	<i>Symbol</i>	<i>Definition</i>
(1)	(2)	(3)
i)	P	Pressure instruments
ii)	T	Temperature instruments
iii)	L	Level instruments
iv)	IL	Interface level instruments
v)	F	Flow instruments
vi)	A	Analyser instruments
vii)	PCV	Self-actuated pressure control valve
viii)	TW	Thermowell

Table (Continued)

<i>Sl No.</i>	<i>Symbol</i>	<i>Definition</i>
(1)	(2)	(3)
ix)	TE	Temperature element
x)	PB	Push button
xi)	SOV	Solenoid operated valve
xii)	TJI	Multipoint indicator
xiii)	DPG	Differential pressure gauge
xiv)	DIC	Differential indicating controller
xv)	DRC	Differential recording controller
xvi)	I	Indicator
xvii)	R	Recorder
xviii)	IC	Indicating controller
xix)	RC	Recording controller
xx)	Y	Function (modifier)
xxi)	Q	Integrator (summator)
xxii)	AL	Alarm low
xxiii)	AH	Alarm high
xxiv)	ALL	Alarm low
xxv)	AHH	Alarm high
xxvi)	SL	Switch low
xxvii)	SH	Switch high
xxviii)	SLL	Switch low
xxix)	SHH	Switch high
xxx)	PI	Pressure indicator
xxxi)	TI	Temperature indicator
xxxii)	LI	Level indicator
xxxiii)	ILG	Interface level gauge
xxxiv)	FE	Flow element
xxxv)	AE	Analyser element
xxxvi)	PT	Pressure transmitter
xxxvii)	LT	Level transmitter
xxxviii)	FT	Flow transmitter
xxxix)	AT	Analyser transmitter
xl)	ILT	Interface level transmitter
xli)	PV	Pressure control valve
xlii)	TV	Temperature control valve
xliii)	LV	Level control valve
xliv)	ILV	Interface level control valve
xlv)	FV	Flow control valve
xlvi)	AV	Gas actuated valve
xlvii)	I/P	Current to pneumatic transducer
xlviii)	P/I	Pneumatic to current transducer
xlix)	I/E	Current to volts transducer
l)	E/I	Volts to current transducer

**Table (Concluded)**

<i>Sl No.</i>	<i>Symbol</i>	<i>Definition</i>
(1)	(2)	(3)
li)	E/P	Volts to pneumatic transducer
lii)	P/E	Pneumatic to volts transducer
liii)	SDV	Shut down valve
liv)	MOV	Motor operated valve
lv)	XL	Running light
lvi)	XI	Running indications
lvii)	TT	Temperature transmitter
lviii)	SC	Sample cooler
lix)	UC	Utility connection
lx)	FG	Flow class
lxi)	PSV	Pressure safety valve
lxii)	TSV	Thermal safety valve
lxiii)	RD	Rupture disk
lxiv)	HIC	Hand indicating controller
lxv)	HCV	Hand control valve
lxvi)	SS	Selection switch
lxvii)	FO	Control valve fail open
lxviii)	FC	Control valve fail close
lxix)	FL	Control valve fall lock
lxx)	TSO	Tight shut off
lxxi)	PVRV	Breather valve (pressure vacuum relief valve)
lxxii)	AF	Flame arrestor
lxxiii)	EX	Excess flow check valve
lxxiv)	RTU	Remote terminal unit
lxxv)	IJ	Insulation joint
lxxvi)	LSS	Low signal selector
lxxvii)	MSS	Manual signal selector
lxxviii)	LO	Lock open
lxxix)	LC	Lock close
lxxx)	ZSH	Position switch high (valve open)
lxxxi)	ZHH	Position high (valve open)
lxxxii)	ZAH	Position alarm high (valve open)
lxxxiii)	ZSL	Position switch low (valve close)
lxxxiv)	ZLL	Position low (full closed valve)
lxxxv)	ZAL	Position alarm low (valve closed)
lxxxvi)	FB	Full bore
lxxxvii)	NB	Normal bore
lxxxviii)	AS	Automatic sampler
lxxxix)	DPT	Differential pressure transmitter
xc)	FO	Restriction orifice
xci)	C	Controller
xcii)	UV	On-Off valve

**Table 1 Identification Letters**

(Clause 2.2)





SI No.	Symbol	First Letter		Succeeding Letter		
		Measured or Initiating Variables	Modifier	Read out or Passive Function	Output Function	Modifier
(1)	(2)	(3)	(4)	(5)	(6)	(7)
i)	A	Analysis	—	Alarm	—	—
ii)	B	Burner, combustion	—	User's choice	User's choice	User's choice
iii)	C	User's choice	—	—	Control	—
iv)	D	User's choice	Differential	—	—	—
v)	E	Voltage	—	Sensor (primary element)	—	—
vi)	F	Flow rate	Ratio (fraction)	—	—	—
vii)	G	User's choice	—	Glass, viewing device	—	—
viii)	H	Hand	—	—	—	High
ix)	I	Current (electrical)	—	Indicate	—	—
x)	J	Power	Scan	—	—	—
xi)	K	Time, time schedule	Time rate change	—	Control station	—
xii)	L	Level	—	Light	—	Low
xiii)	M	User's choice	Momentary	—	—	Middle intermediate
xiv)	N	User's choice	—	User's choice	User's choice	User's choice
xv)	O	User's choice	—	Office, restriction	—	—
xvi)	P	Pressure, vacuum	—	Point (test) connection	—	—
xvii)	Q	Quantity	Integrate, totalise	—	—	—
xviii)	R	Radiation	—	Record	—	—
xix)	S	Speed, frequency	Safety	—	Switch	—
xx)	T	Temperature	—	—	Transmit	—
xxi)	U	Multivariable	—	Multifunction	Multifunction	Multifunction
xxii)	V	Vibration mechanical analysis	—	—	Valve, damper, louver	—
xxiii)	W	Weight, force	—	Well	—	—
xxiv)	X	Unclassified	X-axis	Unclassified	Unclassified	Unclassified
xxv)	Y	Event, state or pressure	Y-axis	—	Relay, compute, convert	—
xxvi)	Z	Position, dimension	Z-axis	—	Driver, actuator unclassified final control element	—

SECTION 07 PUMPS

Sl No.	Symbol No.	Description	Symbols	Remarks
(1)	(2)	(3)	(4)	(5)
i)	0701	Centrifugal pumps	<p>PFD SYMBOL</p> <p>P&amp;ID SYMBOL</p>	<p>GEAR PUMP</p>
ii)	0702	Positive displacement pump	<p>PLUNGER PUMP</p> <p>DUPLEX PUMP</p>	<p>RECIPROCATING PUMP</p>
iii)	0703	Proportioning pump		
iv)	0704	Hand pump with drum		
v)	0705	Ejector (vapour service)	<p>PROCESS FLUID</p> <p>MOTIVE FLUID</p>	
vi)	0706	Blowing egg		

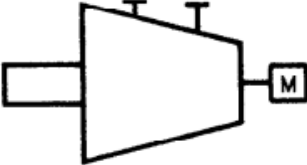
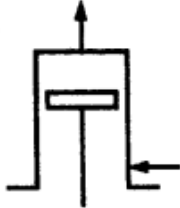
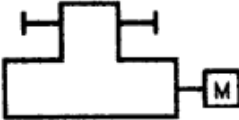
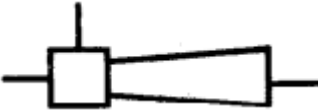

**SECTION 08 COMPRESSORS**

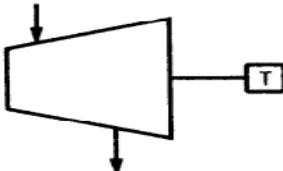
<i>Sl No.</i>	<i>Symbol No.</i>	<i>Description</i>	<i>Symbols</i>	<i>Remarks</i>
(1)	(2)	(3)	(4)	(5)
i)	0801	Centrifugal compressor		
ii)	0802	Positive displacement compressor		
iii)	0803	Reciprocating compressor		
iv)	0804	Ejector compressor		
v)	0805	Fan		
vi)	0806	Turbine		

**SECTION 09 HEATING OR COOLING ARRANGEMENTS**



<i>Sl No.</i>	<i>Symbol No.</i>	<i>Description</i>	<i>Symbols</i>	<i>Remarks</i>
(1)	(2)	(3)	(4)	(5)
i)	0901	Immersion coil	 	EXAMPLES—  

Table (Continued)







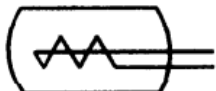
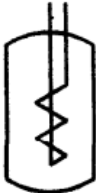

Sl No.	Symbol No.	Description	Symbols	Remarks
(1)	(2)	(3)	(4)	(5)
ii)	0902	Exchanger (in PFD)		
iii)	0903	Heat exchanger		
iv)	0904	Exchanger		
v)	0905	Exchanger		
vi)	0906	Kettle reboiler		
vii)	0907	Kettle reboiler		
viii)	0908	Kettle reboiler 2 – bundle		
ix)	0909	Tubular coil		EXAMPLE :- 
x)	0910	Jacket		EXAMPLE :- 

Table (Continued)

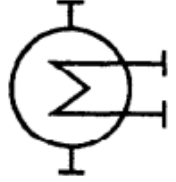
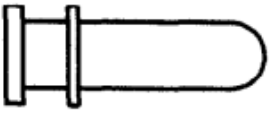
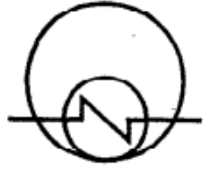

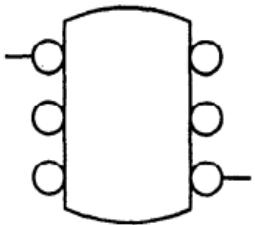

Sl No.	Symbol No.	Description	Symbols	Remarks
(1)	(2)	(3)	(4)	(5)
xi)	0911	Natural draught cooling tower		
xii)	0912	Induced draught cooling tower		
xiii)	0913	Air blown cooler		Used for PFD
xiv)	0914	Trickle cooler		
xv)	0915	Plate type heat exchanger		
xvi)	0916	Air cooler with fan and motor		Used for P&I
xvii)	0917	Contact condenser		
xviii)	0918	Desuper heater		

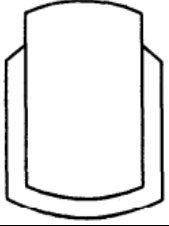
Table (Concluded)

Sl No.	Symbol No.	Description	Symbols	Remarks
(1)	(2)	(3)	(4)	(5)
xix)	0919	One cell fired heater/furnace		
xx)	0920	Two cell fired heater/furnace		

**SECTION 10 FURNACES AND BOILERS**

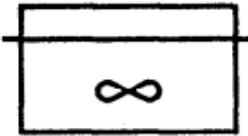
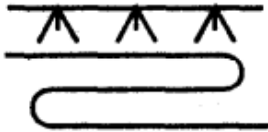
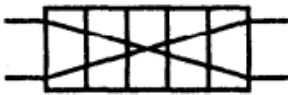
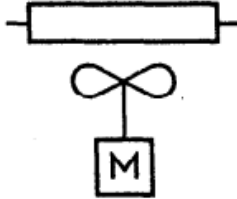
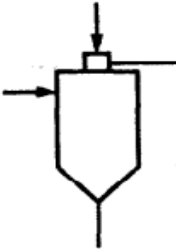
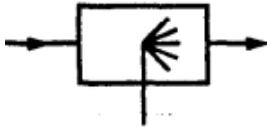
Sl No.	Symbol No.	Description	Symbols	Remarks
(1)	(2)	(3)	(4)	(5)
i)	1001	Solid fuel furnace		
ii)	1002	Oil, gas or pulverized fuel furnace		
iii)	1003	Electric furnace		
iv)	1004	Fired boiler		
v)	1005	Waste heat boiler		

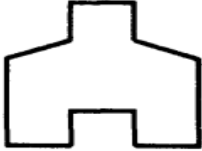
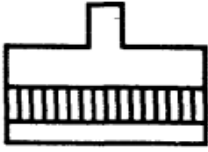
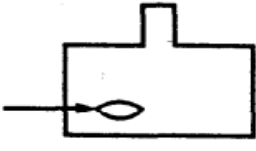
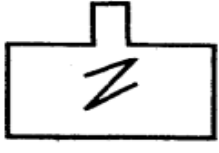
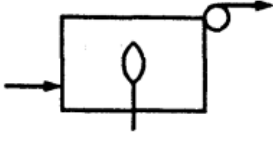
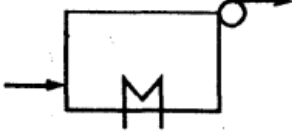
## SECTION 11 PROCESS VESSELS





<i>Sl No.</i>	<i>Symbol No.</i>	<i>Description</i>	<i>Symbols</i>	<i>Remarks</i>
(1)	(2)	(3)	(4)	(5)
i)	1101	Horizontal vessel		
ii)	1102	Vertical vessel		
iii)	1103	Jacketed vessel		
iv)	1104	Packed vessel		
v)	1105	Evaporator		
vi)	1106	Crystallizer		
vii)	1107	Autoclave		
viii)	1108	Construction inside containers, columns towers and reactors		

Table (Continued)



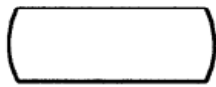
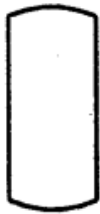

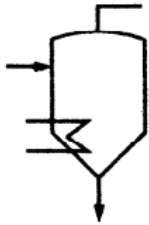
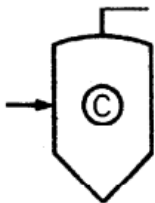

Sl No.	Symbol No.	Description	Symbols	Remarks
(1)	(2)	(3)	(4)	(5)
ix)	1108A	Plates/trays (for mass transfer)		 <p><i>Example:</i> Tray should be numbered from the bottom at least the first and last should be shown. Intermediate tray should be included and numbered where they are significant.</p>
x)	1108B	Fluidized bed		
xi)	1109	Multi bed packed column		
xii)	1110	Vessel with boot		
xiii)	1111	Deaerator		
xiv)	1112	Flanged vessel		
xv)	1113	Double flanged vessel		
xvi)	1114	Conical bottom vessel		

Table (Concluded)

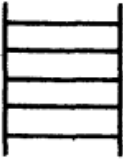
<i>Sl No.</i>	<i>Symbol No.</i>	<i>Description</i>	<i>Symbols</i>	<i>Remarks</i>
(1)	(2)	(3)	(4)	(5)
xvii)	1115	Vessel with one-sump		
xviii)	1116	Vessel with two-sumps		

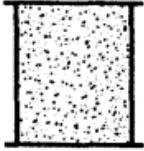
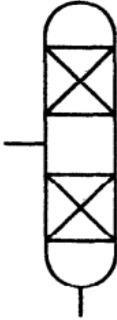
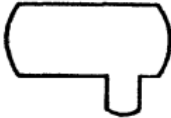

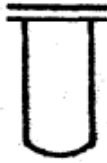
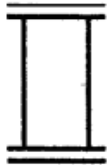
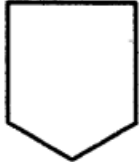
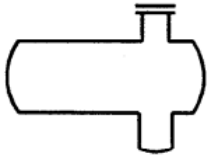
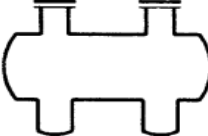
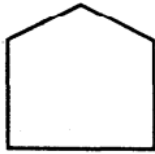
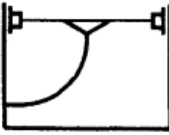
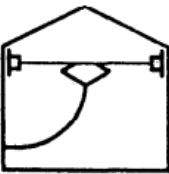
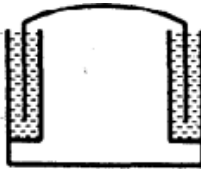
## SECTION 12 STORAGE VESSELS/TANKS

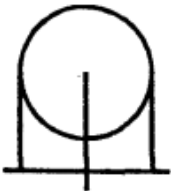
<i>Sl No.</i>	<i>Symbol No.</i>	<i>Description</i>	<i>Symbols</i>	<i>Remarks</i>
(1)	(2)	(3)	(4)	(5)
i)	1201	Fixed roof tank		
ii)	1202	Floating roof tank		
iii)	1203	Floating cum fixed roof tank		
iv)	1204	Gas holder, wet seal		
v)	1205	Gas holder, dry seal		
vi)	1206	Pressure storage (sphere or spheroid) Horton sphere		

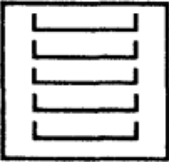
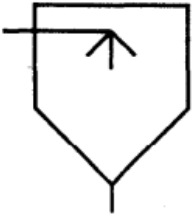
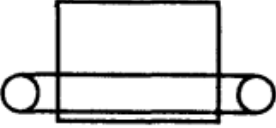
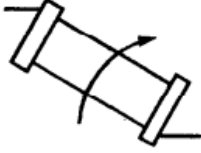
**SECTION 13 DRYERS**





<i>Sl No.</i>	<i>Symbol No.</i>	<i>Description</i>	<i>Symbols</i>	<i>Remarks</i>
(1)	(2)	(3)	(4)	(5)
i)	1301	Batch tray drier		
ii)	1302	Spray drier		
iii)	1303	Continuous drier		
iv)	1304	Rotary drier or kiln		

**SECTION 14 SIZE REDUCTION EQUIPMENTS**

<i>Sl No.</i>	<i>Symbol No.</i>	<i>Description</i>	<i>Symbols</i>	<i>Remarks</i>
(1)	(2)	(3)	(4)	(5)
i)	1401	Size reducing equipment (general symbol)		<i>Example: Pulverizer</i>
ii)	1402	Breaker, gyratory		
iii)	1403	Breaker hammer mill impact mill		

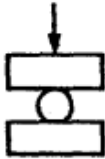

**Table (Concluded)**

<i>Sl No.</i>	<i>Symbol No.</i>	<i>Description</i>	<i>Symbols</i>	<i>Remarks</i>
(1)	(2)	(3)	(4)	(5)
iv)	1404	Jaw crusher		
v)	1404A	Roller crusher		
vi)	1405	Grinder		
vii)	1406	Ball or Tube mill		

**SECTION 15 SEPARATORS**

<i>Sl No.</i>	<i>Symbol No.</i>	<i>Description</i>	<i>Symbols</i>	<i>Remarks</i>
(1)	(2)	(3)	(4)	(5)
i)	1501	Cyclone or hydrocyclone		
ii)	1502	Electrostatic separator (electrical purification of gas)		
iii)	1503	Separators for liquids, decanters		

Table (Concluded)

Sl No.	Symbol No.	Description	Symbols	Remarks
(1)	(2)	(3)	(4)	(5)
iv)	1504	Thickener		
v)	1505	Screen	<p>SCREEN, VIBRATORY</p> 	<p>SCREEN, ROTARY</p> 

SECTION 16 FILTERS



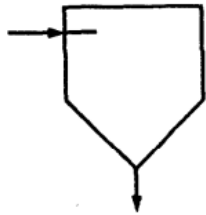
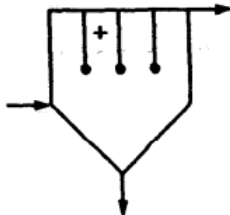
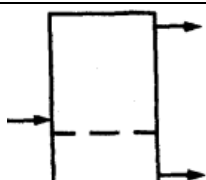
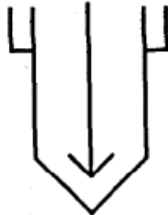
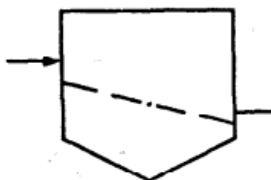
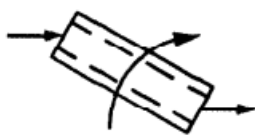

Sl No.	Symbol No.	Description	Symbols	Remarks
(1)	(2)	(3)	(4)	(5)
i)	1601	Filter press		
ii)	1602	Suction filter		
iii)	1603	Pressure filter		
iv)	1604	Gravity filter (open settling tank)		
v)	1605	Open rotary vacuum filter		
vi)	1606	Closed rotary vacuum filter		

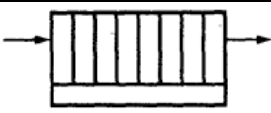
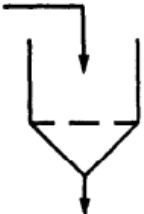
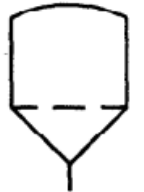
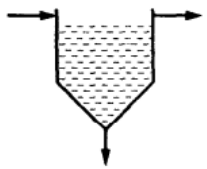

Table (Concluded)

Sl No.	Symbol No.	Description	Symbols	Remarks
(1)	(2)	(3)	(4)	(5)
vii)	1607	Bag filter		BASKET FILTER 



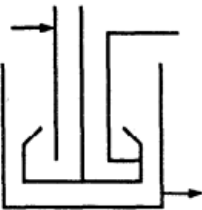
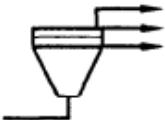
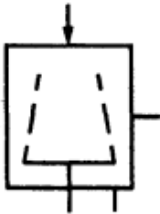
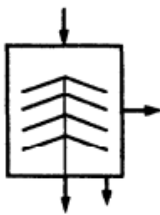

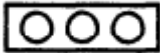
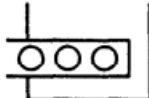

SECTION 17 CENTRIFUGES

Sl No.	Symbol No.	Description	Symbols	Remarks
(1)	(2)	(3)	(4)	(5)
i)	1701	Centrifuges (general symbol)		ALTERNATIVE 
ii)	1702	Basket centrifuge batch or continuous		
iii)	1703	Plate centrifuge		

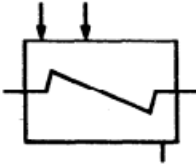
SECTION 18 STIRRERS

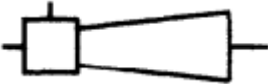
Sl No.	Symbol No.	Description	Symbols	Remarks
(1)	(2)	(3)	(4)	(5)
i)	1801	General symbol		EXAMPLE:- 
ii)	1802	Sparger		EXAMPLE:- 

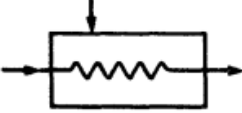
**SECTION 19 MIXERS**

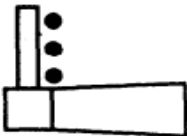
<i>Sl No.</i>	<i>Symbol No.</i>	<i>Description</i>	<i>Symbols</i>	<i>Remarks</i>
(1)	(2)	(3)	(4)	(5)
i)	1901	Ribbon blender		
ii)	1902	Kneader		
iii)	1903	Double cone blender		
iv)	1904	Ejector mixer		
v)	1905	Rotary mixer		
vi)	1906	On-line mixer		
vii)	1907	Mixer		
viii)	1908	Saucony mixer		

**SECTION 20 FEEDERS**

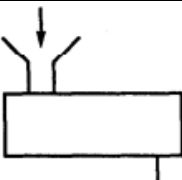
<i>Sl No.</i>	<i>Symbol No.</i>	<i>Description</i>	<i>Symbols</i>	<i>Remarks</i>
(1)	(2)	(3)	(4)	(5)
i)	2001	General symbol		

**Table (Concluded)**

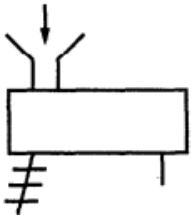
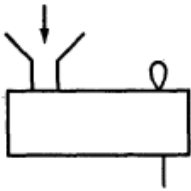
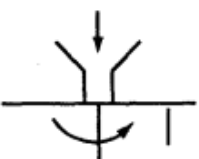
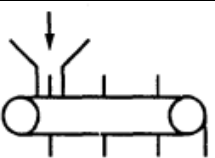
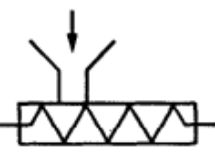
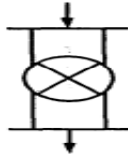
<i>Sl No.</i>	<i>Symbol No.</i>	<i>Description</i>	<i>Symbols</i>	<i>Remarks</i>
(1)	(2)	(3)	(4)	(5)
ii)	2002	Vibrator feeder		
iii)	2003	Weigh feeder		
iv)	2004	Rotary table feeder, revolving plate feeder		
v)	2005	Scraper feeder		
vi)	2006	Screw feeder		
vii)	2007	Rotary feeder		

**SECTION 21 CONVEYORS**





<i>Sl No.</i>	<i>Symbol No.</i>	<i>Description</i>	<i>Symbols</i>	<i>Remarks</i>
(1)	(2)	(3)	(4)	(5)
i)	2101	Belt conveyor		
ii)	2102	Scraper conveyor		

Table (Concluded)

Sl No.	Symbol No.	Description	Symbols	Remarks
(1)	(2)	(3)	(4)	(5)
iii)	2103	Vibrating conveyer		
iv)	2104	Screw conveyer		
v)	2105	Bucket conveyer		
vi)	2106	Roller conveyer		
vii)	2107	Overhead conveyer with hooks		
viii)	2107B	Overhead conveyer or ropeway with buckets or carriers		
ix)	2108A	Fixed hoist with hook		
x)	2108B	Travelling hoist with hook		
xi)	2108C	Travelling hoist with grab		
xii)	2108D	Air floats		

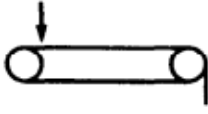
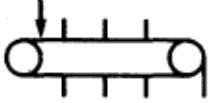
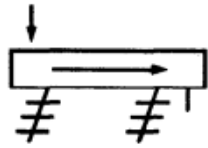
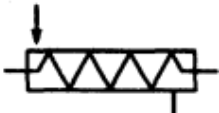
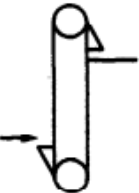
SECTION 22 TRANSPORT VEHICLES

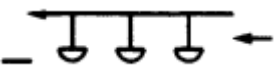

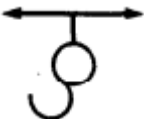
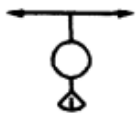
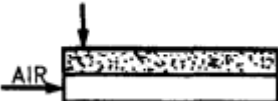
Sl No.	Symbol No.	Description	Symbols	Remarks
(1)	(2)	(3)	(4)	(5)
i)	2201	Ship		

Table (Concluded)

<i>Sl No.</i>	<i>Symbol No.</i>	<i>Description</i>	<i>Symbols</i>	<i>Remarks</i>
(1)	(2)	(3)	(4)	(5)
ii)	2202	Wagon, lorry, truck		
iii)	2203	Tanker		
iv)	2204	Open trailer		
v)	2205	Wagon with bottom hopper		

## SECTION 23 MISCELLANEOUS

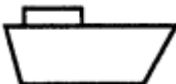
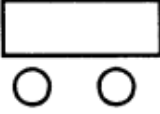
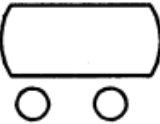
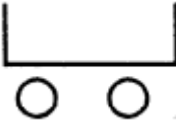
<i>Sl No.</i>	<i>Symbol No.</i>	<i>Description</i>	<i>Symbols</i>	<i>Remarks</i>
(1)	(2)	(3)	(4)	(5)
i)	2301	Silencer		
ii)	2302	Launcher receiver		
iii)	2303	Diesel generator		
iv)	2304	Turbine generator		

Table (Continued)





Sl No.	Symbol No.	Description	Symbols	Remarks
(1)	(2)	(3)	(4)	(5)
v)	2305	Hose reel		
vi)	2306A	Well head with one bore (single completion)		
vii)	2306B	Well head with two bore (dual completion)		
viii)	2307	Sump caisson		
ix)	2308	Flare		
x)	2308B	Flare stack		

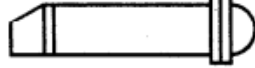
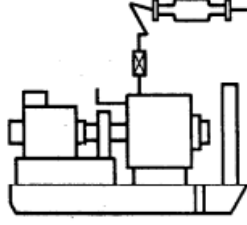
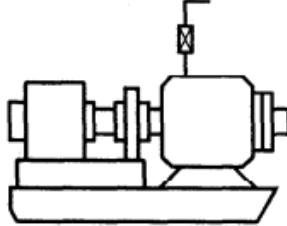

Table (Continued)

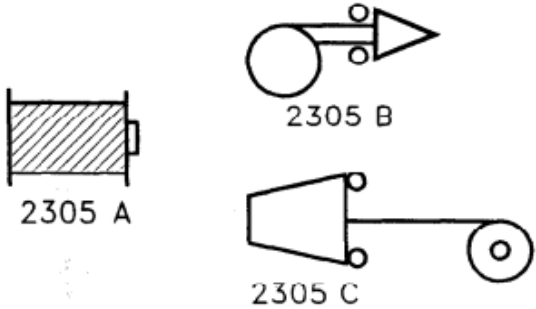

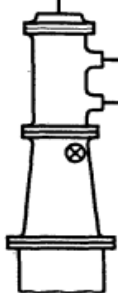
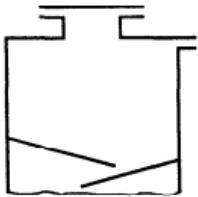
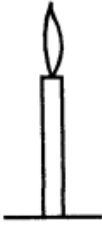



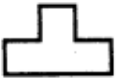

<i>Sl No.</i>	<i>Symbol No.</i>	<i>Description</i>	<i>Symbols</i>	<i>Remarks</i>
(1)	(2)	(3)	(4)	(5)
xi)	2309	Chimney		
xii)	2310	Scraper tee		
xiii)	2311	Atmospheric vent		
xiv)	2312	Cylinder		
xv)	2313	Graduated cylinder		
xvi)	2314	Crane		
xvii)	2315A	Electrolytic cell without diaphragm		
xviii)	2315B	Electrolytic cell with diaphragm		
xix)	2316	Turbine drive		
xx)	2317	Motor drive		

Table (Concluded)

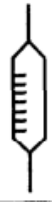
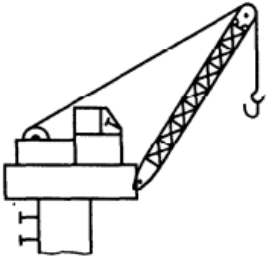
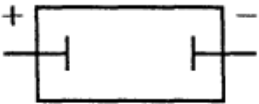
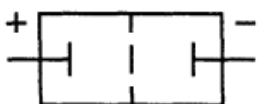
<i>Sl No.</i>	<i>Symbol No.</i>	<i>Description</i>	<i>Symbols</i>	<i>Remarks</i>
(1)	(2)	(3)	(4)	(5)
xxi)	2318	Swivel drain		
xxii)	2319	CBD-symbol		
xxiii)	2320	Sample cooler		

## SECTION 24 SERVICE FLUID CODES

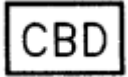
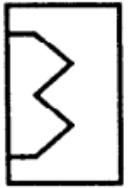
<i>Sl No.</i>	<i>Codes</i>	<i>Meaning</i>
(1)	(2)	(3)
i)	P	Process
ii)	WCS	Cooling water supply
iii)	WCR	Cooling water return
iv)	WD	Drinking water
v)	WS	Service water
vi)	WF	Fire water
vii)	WR	Raw water
viii)	WP	Process water
ix)	WT	Treated water
x)	AI	Instrument air
xi)	AP	Plant air
xii)	AB	Breathing air
xiii)	BD	Blow down
xiv)	FL	Flare
xv)	FO	Fuel oil
xvi)	FG	Fuel gas
xvii)	GI	Instrument gas
xviii)	IG	Inert gas
xix)	OWS	Only water sewer
xx)	SS	Strom sever
xxi)	CBD	Closed blow down
xxii)	D	Drain
xxiii)	UC	Utility connection
xxiv)	HM	Heating medium
xxv)	HMS	Heating medium supply
xxvi)	HMR	Heating medium return

**Table (Concluded)**

<i>Sl No.</i>	<i>Codes</i>	<i>Meaning</i>
(1)	(2)	(3)
xxvii)	EG	50 percent EG solution
xxviii)	CHWS	Chilled water supply
xxix)	CHWR	Chilled water return
xxx)	WDM	Demineralised water
xxxi)	SH	SP steam
xxxii)	SM	MP steam
xxxiii)	SL	LP steam
xxxiv)	CH	Condensate HP
xxxv)	CM	Condensate MP
xxxvi)	CL	Condensate LP
xxxvii)	N	Nitrogen
xxxviii)	BR	Brine
xxxix)	CS	Caustic sewer
xl)	NA	Caustic
xli)	RE	Refrigerant ethane
xl ii)	RA	Refrigerant ammonia
xliii)	RP	Refrigerant propane
xliv)	AC	Acid lines

**SECTION 25 INSULATION/TRACING TYPE**

<i>Sl No.</i>	<i>Codes</i>	<i>Meaning</i>
(1)	(2)	(3)
i)	IH	Hot insulation
ii)	IC	Cold insulation
iii)	IS	Safety insulation
iv)	IT	Steam traced
v)	IE	Electric traced
vi)	IA	Acoustic insulation
vii)	IF	Thermal fluid tracing

## ANNEX A

*(Foreword)*

## COMMITTEE COMPOSITION

Chemical Engineering Plants and Related Equipment Sectional Committee, MED 17

<i>Organization</i>	<i>Representative(s)</i>
CSIR - Indian Institute of Petroleum, Dehradun	DR MRITUNJAY KUMAR SHUKLA ( <i>Chairperson</i> )
Advance Valves Global, Noida	SHRI PRANAY S. GARG SHRI CHANDRAKANT WADKAR ( <i>Alternate</i> )
Auma India Private Limited, Bengaluru	SHRI YASHWANT M. JANNU
Bharat Heavy Electrical Limited, New Delhi	SHRI Y. SRINIVASA RAO SHRI ABHISHEK KUMAR PANDEY ( <i>Alternate</i> )
Blast Carboblocks Private Limited, Mumbai	SHRI DHAWAL SAXENA
Central Power Research Institute, Bengaluru	DR P. THOMAS SHRI SADASIVA MURTHY P. ( <i>Alternate I</i> ) SHRI AJITH KUMAR N. ( <i>Alternate II</i> )
Chemtrols Industries Private Limited, New Delhi	SHRI P. KRISHNA KUMAR
Confederation of Indian Industry, New Delhi	SHRI NANDAKUMAR KALATH SHRI ABILASH UTTAM ( <i>Alternate</i> )
Directorate General Factory Advice Service and Labour Institutes, Mumbai	SHRI TANOJ CHANDAN SHRI KUNAL SHARMA ( <i>Alternate</i> )
Engineers India Limited, Gurugram	SHRI HASMUKH K. PARMAR SHRI MRAGANG SHEAKHAR ( <i>Alternate</i> )
GMM Pfaudler Limited, Anand	SHRI DHIRAN PANCHAL SHRI SATVIK PATEL ( <i>Alternate</i> )
Hindustan Petroleum Corporation Limited, Mumbai	SHRI KRISHANU GHOSH SHRI N.K. RAI ( <i>Alternate</i> )
Indian Oil Corporation Limited, New Delhi	SHRI KARAN AGRAWAL
Indian Rubber Manufacturers Research Association, Mumbai	DR K. RAJ KUMAR DR DEBDIPTA BASU ( <i>Alternate</i> )
Indian Valve and Actuator Manufacturers Association (IVAMA), Coimbatore	SHRI R. MURUGANANTHAM SHRI JAY DOSHI ( <i>Alternate</i> )
Kejriwal Casting Limited, Kolkata	SHRI SANDEEP KEJRIWAL
L&T Valves, Chennai	SHRI ROHIT SHARMA SHRI SURIYANARAYANAN ( <i>Alternate</i> )
Lathia Rubber Manufacture Company Private Limited, Mumbai	SHRI SANJIV S. LATHIA
MECON Limited, Ranchi	SHRI YOGENDRA KUMAR SINGH SHRI ARVIND BHUSHAN ( <i>Alternate</i> )

<i>Organization</i>	<i>Representative(s)</i>
Plastics Machinery Manufacturers Association of India (PMMAI), New Delhi	SHRI NANDHA KUMAR T. SHRI PRADIP VANWANI ( <i>Alternate</i> )
Project and Development India Limited, Noida	SHRI SANJIV KUMAR MISHRA SHRI RAJEEV RANJAN KUMAR ( <i>Alternate</i> )
Tata Consulting Engineers Limited, Navi Mumbai	SHRI SHIVNARAYAN PAREEK SHRI SHIREESH S. SWAMI ( <i>Alternate</i> )
BIS Directorate General	SHRI NAVINDRA GAUTAM SCIENTIST 'E'/DIRECTOR AND HEAD (MECHANICAL ENGINEERING) [REPRESENTING DIRECTOR GENERAL ( <i>Ex-officio</i> )]

*Member Secretary*  
MS NEHA THAKUR  
SCIENTIST 'B'/ASSISTANT DIRECTOR  
(MECHANICAL ENGINEERING), BIS





## Bureau of Indian Standards

BIS is a statutory institution established under the *Bureau of Indian Standards Act, 2016* to promote harmonious development of the activities of standardization, marking and quality certification of goods and attending to connected matters in the country.

### Copyright

BIS has the copyright of all its publications. No part of these publications may be reproduced in any form without the prior permission in writing of BIS. This does not preclude the free use, in the course of implementing the standard, of necessary details, such as symbols and sizes, type or grade designations. Enquiries relating to copyright be addressed to the Head (Publication & Sales), BIS.

### Review of Indian Standards

Amendments are issued to standards as the need arises on the basis of comments. Standards are also reviewed periodically; a standard along with amendments is reaffirmed when such review indicates that no changes are needed; if the review indicates that changes are needed, it is taken up for revision. Users of Indian Standards should ascertain that they are in possession of the latest amendments or edition by referring to the website-[www.bis.gov.in](http://www.bis.gov.in) or [www.standardsbis.in](http://www.standardsbis.in).

This Indian Standard has been developed from Doc No.: MED 17 (19915).

### Amendments Issued Since Publication

Amend No.	Date of Issue	Text Affected

## BUREAU OF INDIAN STANDARDS

### Headquarters:

Manak Bhavan, 9 Bahadur Shah Zafar Marg, New Delhi 110002

Telephones: 2323 0131, 2323 3375, 2323 9402

Website: [www.bis.gov.in](http://www.bis.gov.in)

### Regional Offices:

	Telephones
Central : 601/A, Konnectus Tower -1, 6 <sup>th</sup> Floor, DMRC Building, Bhavbhuti Marg, New Delhi 110002	{ 2323 7617
Eastern : 8 <sup>th</sup> Floor, Plot No 7/7 & 7/8, CP Block, Sector V, Salt Lake, Kolkata, West Bengal 700091	{ 2367 0012 2320 9474
Northern : Plot No. 4-A, Sector 27-B, Madhya Marg, Chandigarh 160019	{ 265 9930
Southern : C.I.T. Campus, IV Cross Road, Taramani, Chennai 600113	{ 2254 1442 2254 1216
Western : Plot No. E-9, Road No.-8, MIDC, Andheri (East), Mumbai 400093	{ 2821 8093

**Branches :** AHMEDABAD. BENGALURU. BHOPAL. BHUBANESHWAR. CHANDIGARH. CHENNAI. COIMBATORE. DEHRADUN. DELHI. FARIDABAD. GHAZIABAD. GUWAHATI. HIMACHAL PRADESH. HUBLI. HYDERABAD. JAIPUR. JAMMU & KASHMIR. JAMSHEDPUR. KOCHI. KOLKATA. LUCKNOW. MADURAI. MUMBAI. NAGPUR. NOIDA. PANIPAT. PATNA. PUNE. RAIPUR. RAJKOT. SURAT. VISAKHAPATNAM.