

AMENDMENT NO. 1 DECEMBER 2024
TO
IS/IEC TR 60269-5 : 2014 LOW-VOLTAGE FUSES
PART 5 GUIDANCE FOR THE APPLICATION OF LOW-VOLTAGE FUSES

This amendment to Indian Standard IS/IEC TR 60269-5 : 2014 is identical to Amendment No. 1 (2020) to IEC TR 60269-5 : 2014 issued by International Electrotechnical Commission (IEC).

Price Group 7

2 Normative References

Replace the existing reference to IEC 60269-1:2006 by the following new reference:

IEC 60269-1:2006, *Low-voltage fuses - Part 1: General requirements*
IEC 60269-1:2006/AMD1:2009
IEC 60269-1:2006/AMD2:2014

Replace the existing reference to IEC 60269-4:2009 by the following new reference:

IEC 60269-4, *Low-voltage fuses - Part 4: Supplementary requirements for fuse-links for the protection of semiconductor devices*

Replace the existing reference to IEC 60947-3:2008 by the following new reference:

IEC 60947-3:2015, *Low-voltage switchgear and controlgear - Part 3: Switches, disconnectors, switch-disconnectors and fuse-combination units*

4 Fuse benefits

Replace the existing text of bullet point h) by the following new text:

h) Compact size offers economical overcurrent protections at high short-circuit levels

Add the following new bullet point after point p):

q) Fuse-links will operate independent of the operation position of the fuse. The operation position is usually vertical. Other positions of use are permissible. The deratings of the manufacturers of the fuse must be observed.

5 Fuse construction and operation

5.2.1 Fuse-link

Replace the existing third paragraph of 5.2.1 by the following new text:

The fuse-element is usually made of flat silver or copper with multiple restrictions in the cross-section. This restriction is an important feature of fuse design, normally achieved by precision stamping.

Replace the existing first sentence of the fourth paragraph of 5.2.1 by the following new text:

M-effect (see 5.3.3) is sometimes added to the fuse-element to achieve controlled fuse operation in the overload range.

5.3.2 Fuse operation in case of short-circuit

Replace the existing bullet points by the following new text:

- the arcing stage (t_a): the arcs begin at restrictions and are then extinguished by the filler.
- M-effect (see 5.3.3) is sometimes added to the fuse-element to achieve controlled fuse operation in the overload range;

5.3.3 Fuse operation in case of overload

Replace the existing third bullet point by the following new text:

- Both stages make up the fuse operating time ($t_m + t_a$). The energy generated in the circuit by the overload current during pre-arcing (melting) time and operating time can still be represented by the pre-arcing I^2t and operating I^2t values, respectively; however under overload conditions the pre-arcing I^2t value is so high it provides little useful application data and the pre-arcing time is the preferred measure for times longer than a few cycles or few time constants. In this case, arcing time is negligible compared to the pre-arcing time.

5.3.5 Fuse operation in altitudes exceeding 2 000 m

Replace the second sentence of the first paragraph of 5.3.5 by the following new text:

This is as stated in IEC 60269-1:2014, Subclause 3.2.

Replace the existing second and third paragraphs of 5.3.5 by the following new text:

For the current carrying capacity of a fuse and the cable to be influenced by the cooling effect of the surrounding air, the current carrying capacity is derated with lower air pressure. This can be described by the following approximation:

Above 2 000 m a de-rating factor of 0,5 % for every 100 m above 2 000 m will be required, due to reduced convection of heat and lower air pressure.

6 Fuse-combination units







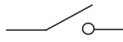

Replace the second sentence of the first paragraph of Clause 6 by the following new text:

Fuse-combination units are shown in Table 2 (equivalent to Table 1 of IEC 60947-3:2008).

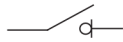
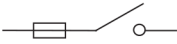
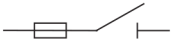
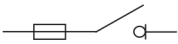
Table 2 – Definitions and symbols of switches and fuse-combination units

Replace existing Table 2 by the following new table:

Amendment No. 1 to IS/IEC TR 60269-5 : 2014

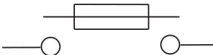
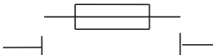
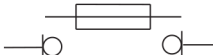
Functions		
Making and breaking current	Isolating	Making, breaking and isolating
Switch 	Disconnector 	Switch-disconnector 
Fuse-combination units		
Switch-fuse single opening ^a 	Disconnector-fuse single opening ^a 	Switch-disconnector-fuse single opening ^a 
Switch-fuse double opening ^b 	Disconnector-fuse double opening 	Switch-disconnector-fuse double opening ^b 
Fuse-switch single opening ^a 	Fuse-disconnector single opening ^a 	Fuse-switch-disconnector single opening ^a 
Fuse-switch double opening ^b 	Fuse-disconnector double opening 	Fuse-switch-disconnector double opening ^b 
NOTE 1 Equipment shown as single opening may comprise multiple openings in series NOTE 2 The symbols do not govern the design of switches, disconnectors and fuse-combination units (Fuse-switches, fuse-disconnectors)		
^a The fuse may be on either side of the contacts of the equipment. ^b Depending on the design, breaking may take place on one or both sides of the fuse-link.		

Replace the existing last paragraph of Clause 6 by the following new text:

The fuse(s) fitted to a fuse-combination unit or fuse-combination switch also protect the unit or the switch itself against the effects of overcurrent.

7 Fuse selection and markings

Renumber the existing note after the second paragraph of Clause 7 as Note 1.

Table 3

Add the following new row to the end of Table 3:

gBat, aBat	Protection of batteries	Full and partial range
------------	-------------------------	------------------------

Replace the text of the final bullet point of the eighth paragraph of Clause 7 by the following new text:

- Size*) or reference

Add the following new note after the final bullet point of the eighth paragraph of Clause 7:

NOTE 2 The definition of fuse sizes, especially the dimensions are given by IEC 60269-2. In general fuse-links and fuse-bases and fuse-combination units shall have the same size. Some manufacturers offer to use a smaller fuse-link size in a bigger fuse-base or fuse-combination unit.

Example: size 1 fuse-link used in size 2 fuse-switch disconnector. Those combinations shall be tested and confirmed by the manufacturer.

8 Conductor protection

Figure 6 – Currents for fuse-link selection

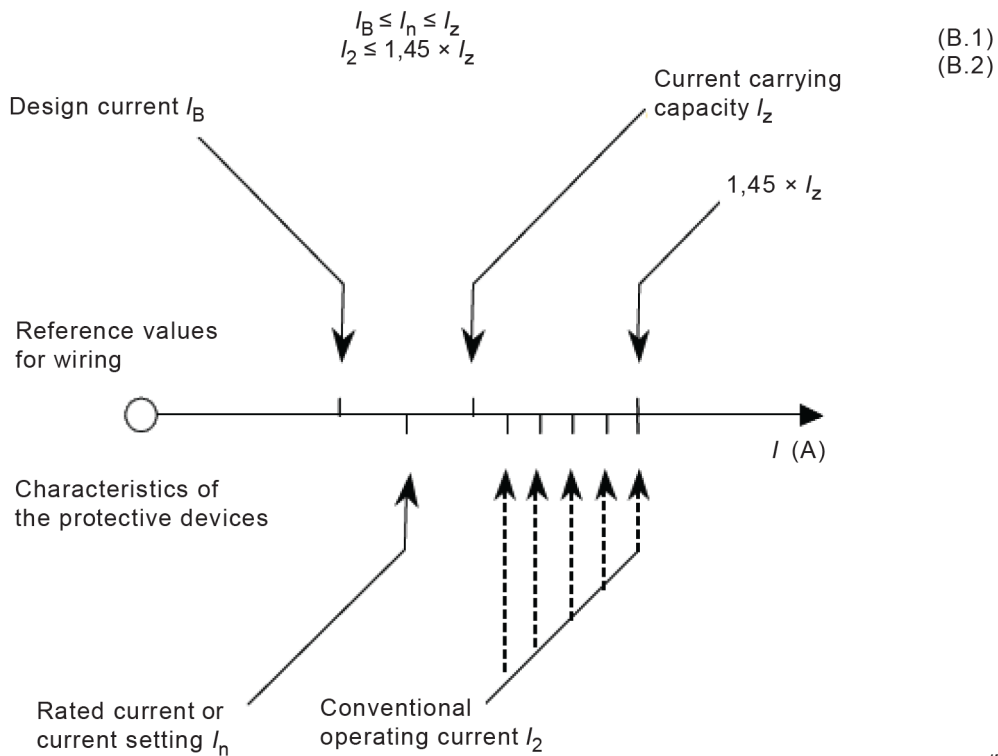

Figure 1 – Currents for fuse-link selection

8.6 Utilization category gK

Replace, in the first sentence of 8.6, "limitating" by "limiting".

8.7 Utilization category gPV

Replace, in the first sentence of 8.7, "(see Clause 19.)" by "(see Clause 19).".

Add the following new Subclause 8.8 and renumber existing Subclause 8.8 as 8.9:

8.8 Utilization category gBat

Selection of a fuse for battery systems. These fuse-links are for overload and short circuit protection.

8.9 Protection against short-circuit current only

Replace, in the first sentence of Subclause 8.9 (formerly 8.8), the phrase "let through I^2t " by "operating I^2t ".

9 Selectivity of protective devices

9.2.1 General

In the second sentence of the NOTE replace the phrase "let through I^2t " by "operating I^2t ".

9.3 Selectivity of circuit upstream breakers of fuses

Replace the existing title of Subclause 9.3 by the following new title:

Selectivity between circuit-breakers upstream and fuses

9.4 Selectivity of upstream fuses of circuit breakers

Replace the existing title of Subclause 9.4 by the following new title:

Selectivity between fuses upstream and circuit-breakers

9.4.3 Verification of selectivity for operating times < 0,1s

Replace, in the first sentence of 9.4.3, the word "prearcing" by "pre-arcing".

Figure 11 – Verification of selectivity between fuse F_2 and circuit-breaker C_3 for operating time $t < 0,1$ s

Replace, in the note to Figure 11, " I_C " by " I_S ".

12 Transformer Protection

12.1 Distribution transformers with a high-voltage primary

Replace the second sentence of the first paragraph of 12.1 by the following new text:

Short-circuit protection of these transformers are generally provided by high voltage fuse-links on the primary, and such fuse-links are selected to withstand the transformer magnetising (inrush) current during energization.

15 Protection of semiconductor devices in a.c. and d.c. rated voltage circuits

Add, at the beginning of Clause 15, the following new Subclause heading:

15.1 General recommendations

Replace the existing text of the second sentence of the third paragraph of Clause 15 by the following new text:

(In this connection, experience has shown that semiconductors fail as a short-circuit protection and a large current results.)

Add, at the end of Clause 15, the following new subclauses:

15.2 Fuse application with inverters

15.2.1 Inverters

Figures 17 to 19 show examples of inverters of voltage source type.

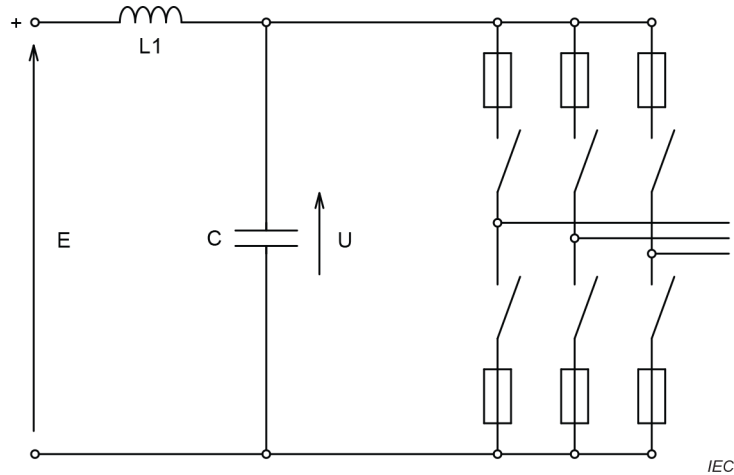

Figure 17 – Inverter double-way connection with arm fuses for regenerative or non-regenerative load

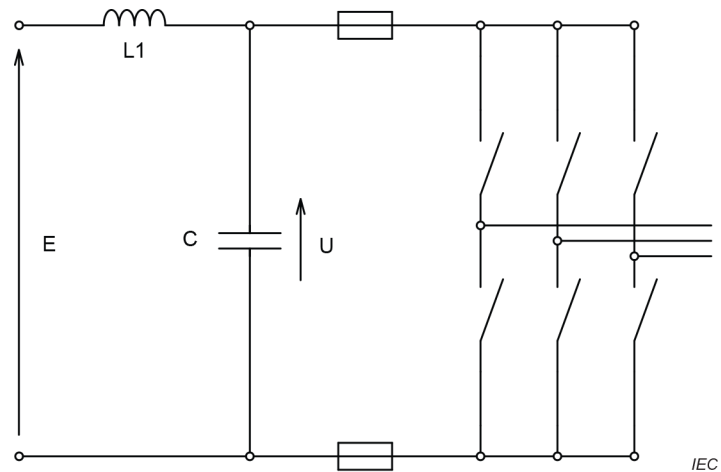

Figure 18 – Inverter double-way connection with d.c. loop fuses for regenerative or non-regenerative load

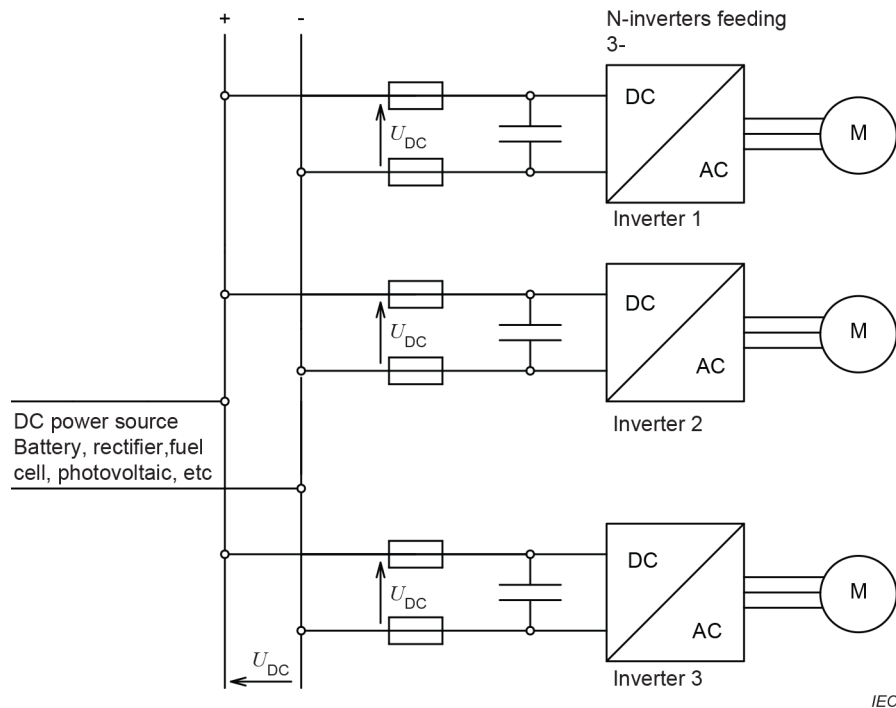

Figure 19 – Multi inverters systems double-way connection with d.c. loop fuses for regenerative or non-regenerative load

Fast fuses can protect the junction of a GTO thyristor against the effect of a large current. As for transistors, IGBT junctions cannot be protected by fuses because of their extremely low I^2t value. Nevertheless, as for other semiconductors, a high fault current will cause the explosion of the IGBT case because of the energy built up inside the component. A lot of power tests demonstrate that the explosion I^2t of the IGBT can be defined and show that fast fuses can prevent an IGBT from exploding.

Moreover tests have been made to measure the fuse contribution to the inductance of the circuit and the effect of high frequencies on the current carrying capability of the fuse. The fuse technology and the circuit design play a great part in the total inductance of the circuit.

The publication of appropriate curves and data is absolutely necessary to allow the selection of a fuse for the protection of power inverters.

15.2.2 Purpose of the fuse

15.2.2.1 General

The purpose of the fuse is to protect the equipment against a semiconductor explosion or when it is possible to protect the semiconductor junction in case of short circuit.

The fuse's main purpose is then to stop the capacitor discharge due to a short circuit made by two arms in series conducting simultaneously.

Two arms will create such a short circuit when one semiconductor is triggered at the wrong time or fails.

The fuse-link will operate very quickly as the di/dt is generally very high because of the very low value of the inductance L_1 (see Figure 20).

The short circuit current is the sum of the capacitor discharge current i_c and the d.c. current i_d coming from the d.c. power source (Figure 6).

However the value of the inductance L (between the power source and the capacitor) is much larger than the value of the inductance of the capacitor discharge current. Then when the fuse-link operates the cut-off current I_c **would be** still very small and even negligible in comparison with the capacitor discharge current.

15.2.2.2 Location of the fuse

There are three possibilities:

- fuses in the arms of the inverter (Figure 17)
- fuses in the DC loop of the inverter (Figure 18): fuse current rating is $\sqrt{3}$ times the current rating of the fuse in the arms
- fuses in the DC feeder (Figure 19): between the capacitor and rectifier
- (or another kind of DC power supply)

It is possible to combine Figure 19 and Figure 17 or Figure 19 with Figure 18.

15.2.2.3 Specific characteristics for the fuse selection

When an IGBT or a GTO fails the capacitor is short-circuited and the fuse is protecting a circuit as described in Figure 20.

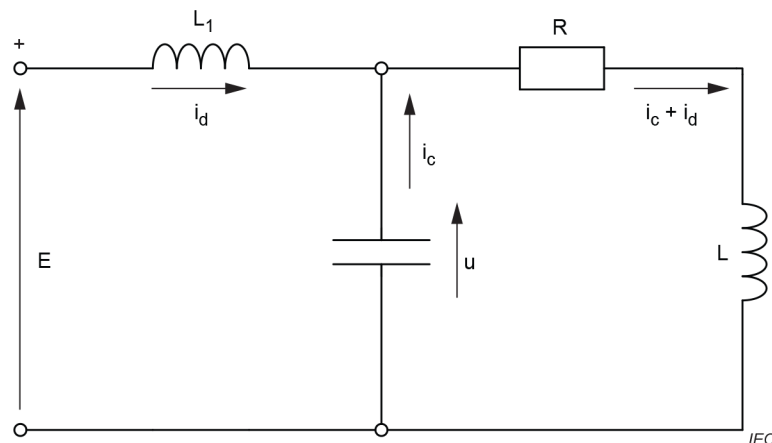

Figure 20 – Capacitor discharge

Amendment No. 1 to IS/IEC TR 60269-5 : 2014

Parameters definition:

E	voltage value of the DC power source-
U	instantaneous value of the voltage across the capacitor
i_{cap}	instantaneous value of the fault current supplied by the capacitor
i_d	instantaneous value of the fault current supplied by the DC power source
L_1	total inductance of the capacitor discharge circuit
L_2	inductance between the DC power source and the capacitor
R	resistance of the capacitor discharge circuit
C	Capacitor

15.2.2.4 Conditions for quick fuse selection

- Inductance:

In such inverters there is an inductance L_1 between the capacitor and the rectifier supplying the d.c. voltage. The L_1 value is normally large compared to the value of L_2 and in most cases it is possible to neglect the current i_d coming from the rectifier during the first half period of the capacitor discharge. In order to neglect i_d it is enough to verify the following condition:

$$L_1 \geq 10 \times L_2$$

- Resistance R:

The resistance value R (including the resistance value of the fuses) is usually low enough to allow an oscillating capacitor discharge. The oscillation condition is:

$$R \leq 2 \cdot \sqrt{\frac{L_2}{C}}$$

This condition on R and the one on L_1 allows the use of the following simplified equations for the calculation of the oscillation period T, the fault current $i(t)$ and voltage $u(t)$:

$$T = 2 \cdot \pi \cdot \sqrt{L_2} \cdot \sqrt{C}$$
$$i(t) = E \cdot \frac{\sqrt{C}}{\sqrt{L_2}} \cdot \exp\left(-\frac{R}{2 \cdot L_2}\right) \cdot \sin \omega t$$
$$u(t) = E \cdot \cos \omega t$$

Higher values of R are acceptable in the circuits, but the simple method of fuse selection cannot be used in this case anymore. A solution can be made by calculating the respective values with specified software tools.

- Voltage across capacitor U

Although the voltage U is oscillating, it does not mean the fuse-link is not working under an AC voltage. After the end of fuse-link pre-arcing time (at time t_p) the arc starts inside the fuse-link and the voltage across the capacitor is not oscillating anymore (the fuse-link is not any more a low resistance). The arcing inside the fuse-link changes the circuit characteristics. At the end of pre-arcing time the voltage U_p across the capacitor is:

$$U_p = E \cdot \cos \omega t$$

Since the fuse-link is arcing under a DC voltage it is necessary to specify the maximum voltage value U_{PM} under which the fuse-link can start arcing. This value is a fuse-link characteristic and it allows to check the following condition:

$$U_p \leq U_{PM}$$

- DC voltage E

Just after the arc extinction, there is a transient phenomenon during the recharge of the capacitor by the power source producing an over voltage across the capacitor, the peak value of which is $U_{transient}$. This value is significantly above the initial value E (Figure 21).

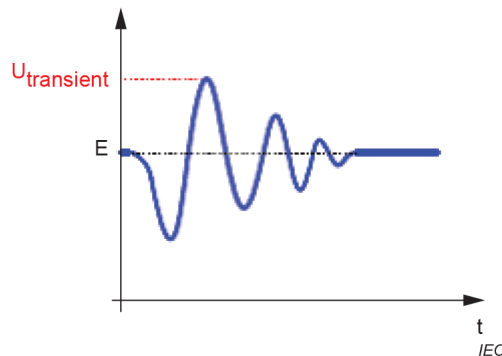

Figure 21 – Voltage across the capacitor

Assuming there is no resistance in the circuit and assuming the capacitor has been fully discharged, the maximum theoretical value of this transient over-voltage is $2 E$.

The realistic value is: $U_{transient} = 1,75 E$

Under such a peak value the arc can restrike inside the fuse-link. Therefore the initial source voltage value E must not exceed a maximum value E_M .

E_M is another fuse-link characteristic. Meeting the following condition is necessary.

$$E \leq E_M$$

- Pre-arcing time t_m

Since the $U_{transient}$ value is function of the voltage decrease across the capacitor during the pre-arcing time of the fuse-link, the pre-arcing time t_m should not be too long. The recommended value when $E = E_M$ is:

$$t_m < T/6$$

When $t_m = T / 6$ the voltage across the capacitor is: $U_p = E / 2$.

Then the maximum transient peak voltage across the capacitor will be about $1,6 E$.

Obviously, these conditions are not critical when the rated DC voltage E is significantly below the E_M value of the selected fuse-link.

- Oscillating period T

The purpose of the condition on T is to limit the time for which the voltage across the capacitor is maximal value. If this condition is not fulfilled the fault interruption is getting closer to the interrupting conditions of a d.c. circuit fed by a battery. The calculations are not anymore the same as the ones mentioned in this document.

The required condition is: $T \leq 10$ ms.

15.2.2.5 Necessary information on fuses

All comments and conditions given in "Conditions for quick fuse selection" mean the fuse manufacturer should publish, within their literature for each fuse, specific value like E_M and U_{PM} and special curves allowing a quick calculation of t_m , pre-arcing I^2t , total I^2t (for example relation with di/dt) and arc voltage U_m .

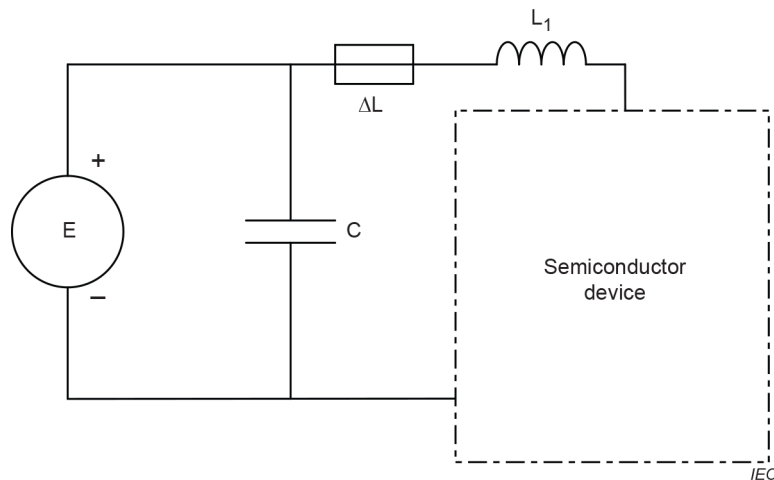

Figure 22 – Inductance of the circuit

The L value of a circuit inductance depends mainly on the shape and length of the circuit. When the fuse is introduced into the circuit, it changes the length and the shape of that the circuit. Consequently the inductance L of the circuit becomes $L + \Delta L$ (Figure 22).

ΔL is not an inductance located inside the fuse having a constant value. Fuse manufacturers measured ΔL of several fuses with the circuit in Figure 22. The value of the circuit with fuse and without fuse is obtained by measuring the di/dt when the circuit is closed.

Without fuse $di / dt = E/L_1$

With fuse $di / dt = E/(L_1 + \Delta L)$

For these measurements the fuse is replaced by a copper bar in order to minimize the change of length of the circuit. The ΔL value drastically decreases when the body of the fuse is flat.

NOTE The IGBT is also a large power component whose case rupture can cause large damages in the equipment and be dangerous to people. The protection of power IGBTs against explosion requires fuses electrically and mechanically adapted up to 7,2 kV, but requires knowing the real explosion i^2t of the IGBT in order to achieve an ideal coordination with the fuse. Fuse manufacturers are able to supply a safe and reliable protection of the IGBT converters. In case of need consult with them or their literature.

15.2.3 Current carrying capacity

15.2.3.1 Fuse rated current selection

When the fuse is intended to carry a continuous current, the RMS value is first calculated on a one-cycle basis, and this RMS value shall remain constant. Unless otherwise indicated by the manufacturer, the rated current shall be:

- at least the RMS value of the current, taking into account, if necessary the conditions, which might be different from standard conditions. For high frequency applications the influence of skin and proximity effect should be considered.

NOTE 1 There is a skin effect in the fuse elements, although they have a thickness smaller than 0.5 mm, because the current density varies alongside the width; there is no skin effect in the thickness as the skin depth is 0.95 mm at 5 kHz. There is a skin effect in contact parts.

NOTE 2 Proximity effect: The current is not equally shared between the fuse elements, when the return busbar is close to the fuse. The unbalance is function of the frequency and of the distance between the fuse and the return busbar (the shorter the distance, the larger the imbalance).

When this distance is above 200 mm and the frequency is lower than 20 kHz the proximity effect inside the fuse becomes negligible. The proximity effect is affecting the fuse behaviour much more than the skin effect.

The skin effect is much less dangerous but not negligible for frequencies above 1 kHz when the connecting bus bars do have higher dimensions.

Another problem with high frequencies is the overheating of magnetic parts due to the hysteresis losses. These losses can be avoided by using non-magnetic materials.

15.2.3.2 Mounting and surrounding ambient conditions

IEC 60146 applies.

15.2.4 Voltage considerations

15.2.4.1 Voltages during fault conditions

See “Voltage across capacitor U” in 15.2.2.2.

15.2.4.2 Selection of the fuse rated voltage

Single inverter: The fuse-link will interrupt the capacitor discharge current generated by the short circuit created by the failure or bad triggering of semiconductors (Figure 17 and Figure 18). The fuse selection is based on the knowledge of the fuse-link maximum DC voltage rating at time constants lower than 1 ms.

In case of multi-inverters systems (Figure 19) the fuses are installed on the DC side of each inverter and will interrupt the capacitor discharge currents from all capacitors in all other feeders (they are in parallel) and the DC current supplied by the DC power source. The fuse selection is based on the knowledge of the fuse-link maximum DC voltage rating at time constants lower than 1 ms.

Condition 1 for fuse voltage selection: Since the fuse-link is arcing under a DC voltage it is necessary to specify the maximum voltage value U_{PM} under which the fuse can start arcing. This value is a fuse-link characteristic and it allows checking the following condition:

$$U_p \leq U_{PM}$$

Condition 2 for fuse voltage selection: Under such a peak value the arc can restrike inside the fuse-link. Therefore the initial source voltage value E must not exceed a maximum value E_M .

$$E \leq E_M$$

15.2.4.3 Maximum arc voltage

IEC 60146 applies. The fuse manufacturer publishes values of maximum arc voltage referring U_p .

15.2.5 I^2t characteristics

The fuse manufacturer publishes in his literature pre-arcing I^2t and total I^2t .

15.2.6 Breaking range

15.2.6.1 Supplementary requirements for fuse-links for the protection of semiconductor devices

IEC 60269-4, *Low-voltage fuses – Part 4: Supplementary requirements for fuse-links for the protection of semiconductor devices*, used the name VSI for the protection of Voltage Source Inverters. IEC 60269-4 includes specific test requirements for fuse-links that can then be **to** assigned a VSI voltage rating. These tests are, due to test laboratory capabilities, the best available at the moment for application with high frequency short circuit currents

15.2.6.2 Frequencies

Inverter applications with frequencies lower than 1 kHz are covered by this document. For frequencies higher than 1 kHz consult the fuse manufacturer or their literature.

19 Photovoltaic (PV) system protection

19.1 General

Insert, in the first line of 19.1, a space behind the word: "string".

19.2.5 Functional earthing fuses

Replace, in the first line of 19.2.5, the word "maybe" by "may be".

19.2.6 PV array and sub-array fuses

Replace, in the first line of 19.2.6, "interupt" by "interrupt".

Add, after Clause 20, the following new Clause 21:

21 Guidance for the selection of a fuse for the protection of Battery systems

21.1 General

This clause is limited to the use of Battery fuse-links in circuits having the characteristics generally found in electrical energy storage systems of the d.c. Installation. It is the object of this annex to explain the selection of the fuse-links.

21.2 Voltage characteristics

21.2.1 Rated voltage

The rated voltage of the fuse-link selected shall be higher than the maximum voltage of the battery system.

In case of polarity inversion protection one fuse link must be installed for each battery polarity. Each single fuse must be able to interrupt the short circuit current under maximum voltage of the system.

21.3 Current carrying capability

21.3.1 Rated current

The rated current of the fuse-link selected shall take into account the operation current profile of the application. Ambient temperature may require higher current ratings of the fuse-link. In such case the manufacturer should be consulted.

21.4. Breaking capacity

The maximum short circuit current of the battery or battery module shall be lower than the rated breaking capacity of the fuse-link.

Annex A Coordination between fuses and contactors/motor-starters

Table A.1

Add the following new NOTE 2 under NOTE 1 of Table A.1:

NOTE 2 For explanation of fuse type gM, see 5.7.1 of IEC 60269-1:2006.

A.4.3 Guidance for choosing the maximum rated current of an alternative fuse type

Replace, in the fourth line of the fifth paragraph of A.4.3, "take" by "the".