

BUREAU OF INDIAN STANDARDS

DRAFT FOR COMMENTS ONLY

*(Not to be reproduced without permission of BIS
or used as an Indian Standard)*

Draft Indian Standard

CARBON DISULPHIDE, TECHNICAL — SPECIFICATION

(Third Revision of IS 717)

(ICS 71.060.99)

Organic Chemicals, Alcohols and
Allied Products Sectional Committee, PCD 9

Last date for Comments
23 September 2023

FOREWORD

(Formal clauses to be added later)

Carbon disulphide was discovered in 1896 while its industrial usage was found in the nineteenth century. Of the total production of carbon disulphide world over about 75 percent is used by the regenerated cellulose industry. The rest is consumed in production of carbon tetrachloride and miscellaneous organosulphur compounds used as rubber chemicals, flotation agents, pesticides and fumigants. It is an excellent solvent for many organic compounds and readily dissolves sulphur, phosphorus, iodine, waxes, rubbers and resins, etc.

Carbon disulphide is commercially manufactured by the reaction of sulphur with charcoal as well as by the reaction of sulphur with natural gas. Carbon disulphide produced from natural gas process reduces environmental impact, the impact is significantly low as compared to carbon disulphide produced from charcoal, as charcoal based process, led to more emissions of sulphur oxide and nitrogen oxide. Ethane, propane and propene are also used to a limited extent.

Carbon disulphide is highly flammable and one of the most toxic hazardous chemicals to handle and thus should be handled carefully and disposed by controlled incineration.

This standard was originally published in 1955 and subsequently revised in 1969 and 1988. In its first revision requirement and methods of test for distillation yield and residue on evaporation were modified.

In second revision, methods of test for distillation yield, relative density, hydrogen sulphide, sulphur dioxide and other reducing substances were modified in view of its volatile nature. Carbon disulphide being highly flammable and corrosive chemical, emphasis was laid on safety and precautions in handling, storing and transportation.

In the preparation of second revision of this standard, assistance was drawn from the following sources:

- a) ISO 3144 : 1974 Carbon disulphide for industrial use-Sampling and methods of test

b) BS 662 (Part 3): 1979 Carbon disulphide for industrial use- Determination of thiophene, benzene, mercaptan (thiol), hydrocarbons and hydrogen sulphide

In this (*third*) revision, description of the material and requirement of residue on evaporation have been modified. Purity being one of the important requirement has been incorporated in this revision. Further, carbon disulphide being highly flammable and corrosive chemical, statement like ‘as agreed between purchase and suppliers’ in packing clause has been modified.

For the purpose of deciding whether a particular requirement of this standard is complied with, the final value, observed or calculated, expressing the result of a test or analysis, shall be rounded off in accordance with IS 2 : 2022 ‘Rules for rounding off numerical values (*second revision*)’. The number of significant places retained in the rounded off value should be the same as that of the specified value in this standard.

1 SCOPE

This standard prescribes the requirements, the methods of sampling and test for carbon disulphide, technical.

2. REFERENCES

The following standards are necessary adjuncts to this standard. The standards contain provisions which through reference in this text constitute provisions of this standard. At the time of publication, the editions indicated were valid. All standards are subject to revision, and parties to agreements based on this standard are encouraged to investigate the possibility of applying the most recent revisions of the standards indicated below.

<i>IS No.</i>	<i>Title</i>
IS 1070 : 2023	Reagent grade water — Specification (<i>fourth revision</i>)
IS 1260 (Part 1) : 1973	Pictorial marking for handling and labelling of goods Dangerous goods (<i>first revision</i>)
IS 1260 (Part 2) : 2020 / ISO 780 : 2015	Packaging — Distribution Packaging — Graphical Symbols for Handling and Storage of Packages: Part 2 General Goods (<i>fourth revision</i>)
IS 1381 (Part 1) : 2003 / ISO 1773 : 1997	Laboratory glassware - Narrow - Necked boiling flasks (<i>second revision</i>)
IS 5685 : 1970	Code of safety for carbon disulphide

3 REQUIREMENTS

3.1 Description

The material shall consist essentially of carbon disulphide (CS₂), and shall be a clear, colourless liquid, free from suspended matter.

3.2 The material shall also comply with the requirements given in Table 1.

Table 1 Requirements of Carbon Disulphide, Technical
(Clause 3.2, 7.2 and B-3.2)

Sl No.	Characteristic	Requirement	Method of test (ref to Annex)
(1)	(2)	(3)	(4)
i)	Relative density at 27 °C/27 °C	1.251 to 1.262	A
ii)	Distillation range percent by volume, <i>Min</i>	95 percent shall distil within 1°C including 46.6°C	B
iii)	Residue on evaporation, percent by mass, <i>Max</i>	0.003	C
iv)	Acidity	Shall not show any acid reaction	D
v)	Hydrogen sulphide, Sulphur dioxide and other reducing substances (as H ₂ S), ppm, <i>Max</i>	5	E
vi)	Purity, percent by mass, <i>Min</i>	99.9	F

4 PRECAUTIONS IN HANDLING

Owing to the high degree of flammability of the material and its vapours and its high volatility at ordinary temperatures, care should be taken at all stages of sampling, storing and testing the material to avoid risks of fire and explosion. The material is also toxic and harmful to human system if vapour or liquid is inhaled or allowed to come into prolonged or repeated contact with the skin. The precautions may be followed as per IS 5685.

5 PACKING AND MARKING

5.1 Packing

5.1.1 The material shall be packed in stoneware, jars or glass stoppered bottles or strong metal cans or drums with screw stoppers.

5.1.2 In case of bulk quantity that is more than 10 tonne, the material shall be packed in ISO T-14 or ISO T-19 containers.

NOTE — Carbon disulphide inside the containers shall be kept covered under a layer of water (minimum 10 mm) or nitrogen (minimum 20 percent volume). In case of water, care should be taken to leave an empty air space of not less than 10 percent.

5.1.3 Necessary safeguard against the risk arising from the storage and handling of this material shall be provided and precautions shall be taken at all times to prevent accident by fire and explosion.

5.1.4 All containers for storage and transport of the material shall, in addition, comply with the requirements of the latest issue of Red Tariff issued by Indian Railway Conference Association; the requirements laid down from time to time by the Chief Inspector of Explosives, Government of India, for packing, storage and transit of flammable liquids.

5.2 Marking

5.2.1 All containers (including containers/tankers for bulk transport) in which the material is stored or transported shall be prominently and clearly marked with the 'HIGHLY FLAMMABLE LIQUID KEEP FIRE AND OPEN FLAME AWAY' along with symbol given in Fig. 5 of IS 1260 (Part 1), and the legend THIS WAY UP along with symbol given in SI No. 13 of Table 5 of IS 1260 (Part 2).

5.2.2 Each container shall be marked with the following information:

- a) Name and grade of the material;
- b) Name of the manufacturer, initials or his trade-mark, if any;
- c) Net weight of the material;
- d) Batch Number;
- e) Month and year of manufacture; and
- f) Any other statutory requirement.

5.2.3 For supplies of material in bulk, a test certificate containing the details mentioned at **5.2.2** shall be provided for each consignment.

5.2.4 *BIS Certification Marking*

The product(s) conforming to the requirements of this standard may be certified as per the conformity assessment schemes under the provisions of the *Bureau of Indian Standards Act, 2016* and the rules and regulations framed thereunder, and the products may be marked with the standard mark.

6 SAMPLING

6.1 The method of drawing representative samples of the material shall be as prescribed in Annex G.

7 TESTS

7.1 The material is when kept under water in storage tanks, it is likely to be contaminated with water. In such a case, the material shall be separated from water and suitably dried before analysis.

7.2 Tests shall be conducted according to the methods referred to in col 4 of Table 1.

7.3 Quality of Reagents

Unless specified otherwise, pure chemicals and distilled water (*see* IS 1070) shall be used in tests.

NOTE - 'Pure chemicals' shall mean chemicals that do not contain impurities which affect the results of analysis.

ANNEX A

[Table 1, Sl No. (i) and C-3]

DETERMINATION OF RELATIVE DENSITY

A-1 GENERAL

In this method, weights of equal volumes of the material and water at the same temperature are compared using relative density bottle.

A-2 APPARATUS

A-2.1 Volumetric Flask / Pyknometer

A-2.2 Water Bath, maintained at 27.0 ± 0.2 °C.

A-3 PROCEDURE

Clean and dry the volumetric flask/pyknometer weight and then fill with recently boiled and cooled water at 27 °C. Fill to overflowing by holding the volumetric flask/pyknometer on its side in such a manner as to prevent entrapment of air bubbles. Insert the stopper and immerse in the water bath. Keep the entire bulb of the volumetric flask/pyknometer completely covered with water and hold at that temperature for 30 min. Carefully, remove any water which had exuded from the capillary opening. Remove from the bath, wipe completely dry, cool and weigh. Calculate the weight of water. Again clean and dry the relative density volumetric flask/pyknometer. Using the material under test, proceed exactly as in the case of water and weigh the volumetric flask/pyknometer with the material.

A-4 CALCULATION

$$\text{Relative density at } 27 \text{ }^{\circ}\text{C}/27 \text{ }^{\circ}\text{C} = \frac{A-B}{C-B}$$

where

A = weight of the volumetric flask/ pyknometer filled with the material, in g;

B = weight of the clean and dry volumetric flask/pyknometer, in g; and

C = weight of the volumetric flask/ pyknometer filled with water, g.

ANNEX B

[Table 1, Sl No. (ii)]

DETERMINATION OF DISTILLATION RANGE

B-1 APPARATUS

B-1.1 Distillation Flask, of the shape and dimension shown in Fig. 1.

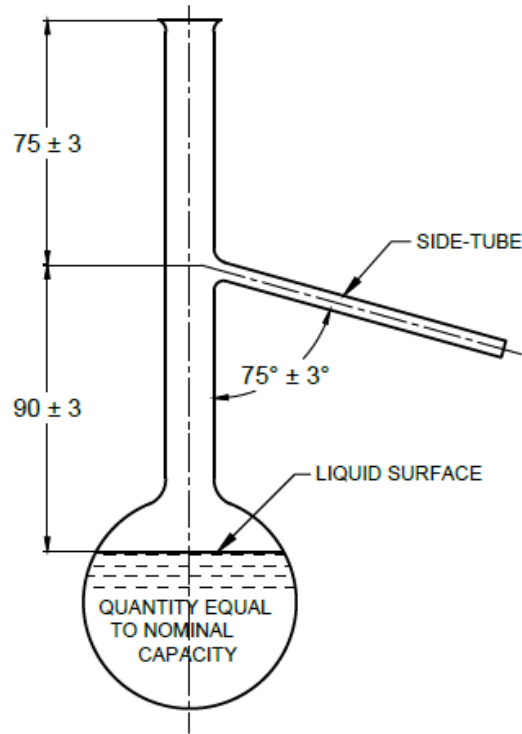

All dimensions in millimeter
FIG. 1 DISTILLATION FLASK

B-1.2 Thermometer, of the mercury-in-glass partial immersion type, having a range between 0 °C to 100 °C, graduated at each 0.2 °C and having a maximum error of 0.4 °C. The thermometer shall have an overall length of 385 mm maximum and stem diameter 5.5 to 8.0 mm.

B-1.3 Liebig Condenser, with bend end and with a wall thickness of 1.0 mm to 1.5 mm and conforming to the shape and dimensions given in Fig. 2.

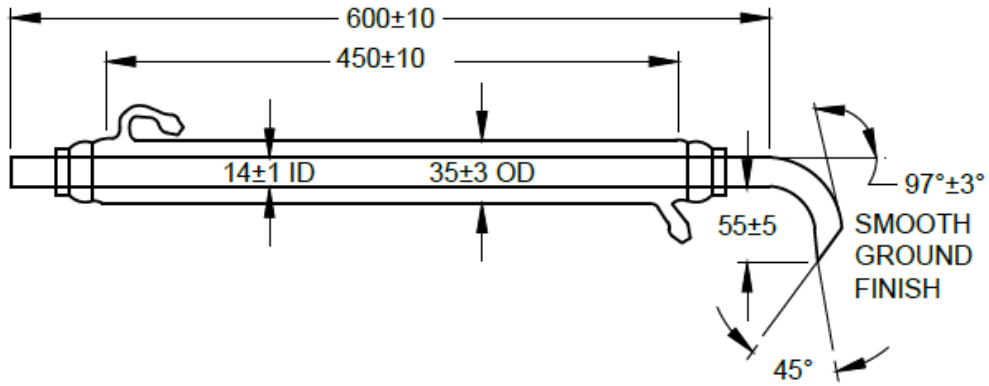

All dimensions in millimeter
FIG. 2 LIEBIG CONDENSER

B-1.4 Receiver, 100 ml capacity, with dimensions and graduations as shown in Fig. 3.

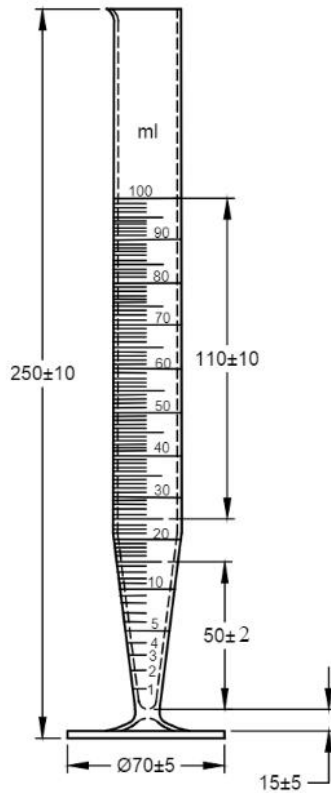

All dimensions in millimeter
FIG. 3 RECIEVER

B-1.5 Constant temperature bath, for receiver to be maintained at 20°C .

B-1.6 Rectangular Draught Screen, rectangular in cross-section made of 0.8 mm thick metal sheet with the dimensions shown in Fig. 4 and open at the top and bottom. It shall comply with the following requirements:

- a) In each of the two narrower sides of the draught screen there shall be two circular air vents 25 mm in diameter, situated below the asbestos shelf, as shown in Fig. 4. In each of the four sides of the draught screen there shall be three air vents with their centres 25 mm above the base of the draught screen. These holes shall occupy the positions shown in Fig.4, the diameter of each of the holes centrally situated in the wider sides being 25 mm, and of the remaining ten holes 12.5 mm. At the middle of each of the wider sides there shall be a vertical slot for the side-tube of the distillation flask, with dimensions as shown in Fig. 4 and cut downwards from the top of the screen. A removable shutter conforming to the dimensions shown in Fig. 5 shall be provided for closing the vertical slot not in use.
- b) A shelf of hard asbestos board, 6 mm in thickness and having a central hole 110 mm in diameter, shall be supported horizontally in the screen and shall fit closely to the sides of the screen to ensure that hot gases from the source of heat do not come in contact with the sides or neck of the flask. The supports for this asbestos shelf may conveniently consist of the triangular pieces of metal sheet firmly fixed to the screen at its four corners.
- c) An asbestos board 150 mm x 150 mm x 6 mm in size having a central hole 50 mm in diameter shall be so placed on the asbestos shelf that the two holes are approximately concentric and the distillation flask when in position completely closes the hole of the asbestos board.

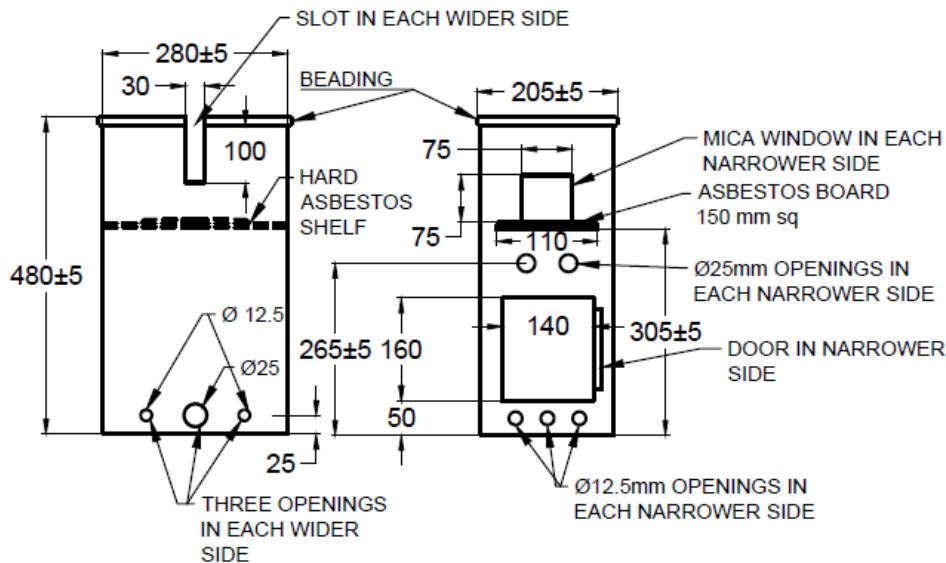

All dimensions in millimeter
FIG. 4 RECTANGULAR DRAUGHT SCREEN

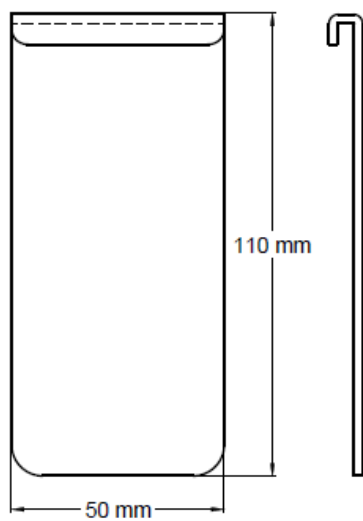

All dimensions in millimeter
FIG. 5 REMOVABLE SHUTTER

B-1.7 Electric Heater, Gas Burner or Other Type Heater

Any suitable heater or burner that enables the distillation to be carried out as described in **B-2**.

B-1.8 Assembly of the Apparatus

Assemble the apparatus as shown in Fig. 6.

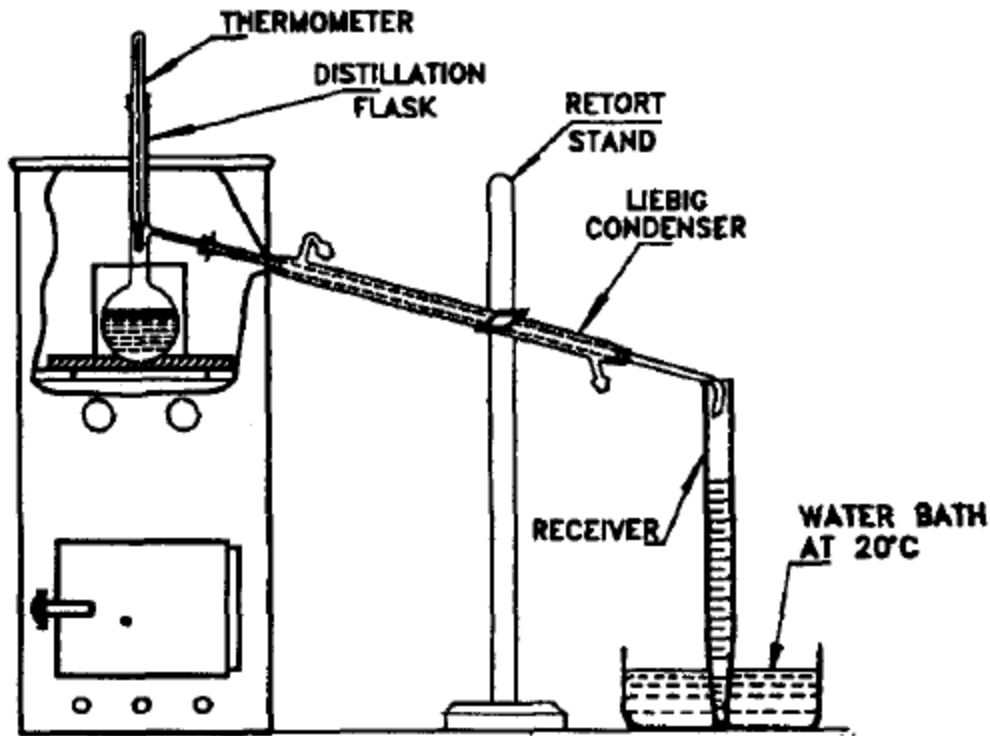

FIG. 6 ASSEMBLY OF APPARATUS

B-1.8.1 *Position of Thermometer*

The thermometer shall be held concentrically in the neck of the flask by means of a well-fitting stopper of a material which is not attacked by the liquid, and the junction of the capillary tube and the main bulb of the thermometer shall be maintained level with the lower edge of the joint of the side-tube and the neck of the flask. The stopper shall project about 10 mm above the top of the neck of the flask. When the thermometer is fixed in position as indicated above, the immersion line on the thermometer shall be in the neighborhood of the top of the cork holding the thermometer.

B-1.8.2 *Support for Flask*

The asbestos board [see **B-1.6(c)**] shall be placed on the top of the asbestos shelf of the draught screen that the two holes are approximately concentric. The flask shall then be placed in position and pressed down so as to close completely the hole in the asbestos board.

B-1.8.3 *Connection of Flask to Liebig Condenser*

The flask is so connected to the condenser that the end of the side-tube projects at least 25 mm into the condenser and is coaxial with it.

B-2 PROCEDURE

B-2.1 Measure 100 ml of the material after cooling it to 20 °C in the receiver. Transfer the liquid as completely as possible to the distillation flask and add a few small pieces of clean, dry porous earthenware or stoneware. Place the flask, thermometer and receiver in position and ensure that the condenser has a steady supply of water. The distillation be carried out in the well ventilated fume cupboard. Apply heat at uniform rate, so regulated that the first drop of distillate falls from the end of the condenser in 5 to 10 min. Further regulate the heat so that the distillate is collected at the rate of 3 to 4 ml per minute. The temperature of the cooling water for condenser should be 20°C, maximum. Record the volume of distillate in the receiver when the thermometer indicates the corrected specified distillation temperature. Disregard any liquid on the side of the flask.

B-3 CORRECTION OF THERMOMETER READING

B-3.1 Error of Scale

In all thermometer readings, make the corrections as indicated on the certificate of the thermometer.

B-3.2 Correction for Barometric Pressure

If the barometric pressure prevailing during the determination is 760 mmHg, no correction need be applied to the specified temperature, and the thermometer scale as corrected under **B-4.1** may be used as such. If the prevailing barometric pressure deviates from 760 mmHg, the specified temperature shall also be corrected as follows:

- a) For every 10 mm above 760 mmHg, subtract 0.40 deg from the observed temperature of boiling range to get the specified temperature range as per Table 1; and
- b) For every 10 mm below 760 mmHg, add 0.40 deg to the observed temperature range to get the specified temperature range as per Table 1.

NOTE — These corrections are valid only for pressure above 700 mmHg.

ANNEX C

[Table 1, Sl No. (iii)]

DETERMINATION OF RESIDUE ON EVAPORATION

C-1 APPARATUS

C-1.1 Conical Flask, stoppered, of 250 ml capacity (*see* IS 1381).

C-1.2 Basin, 30 ml capacity, made of platinum, silica or glass.

C-1.3 Water Bath

C-1.4 Oven, capable of maintaining a temperature of 100 ± 2 °C.

C-2 PROCEDURE

Measure accurately about 200 ml of the material into the conical flask. Add this in small portions at a time to the basin placed on the water-bath and evaporate the whole quantity to dryness in fume cupboard provided with flame-proof exhaust fan. Dry the residue in the oven for one hour at a temperature of 100 ± 2 °C. Cool in a desiccator and weigh.

C-3 CALCULATION

$$\text{Residue on evaporation, percent by weight} = \frac{100 \times W}{V \times D}$$

where

W = weight of the residue, in g;

V = volume of the material taken for the test, in ml; and

D = relative density of the material (*see* Annex A)

ANNEX D

[Table 1, Sl No. (iv)]

DETERMINATION OF ACIDITY

D-1 APPARATUS

D-1.1 Graduated Measuring Cylinder, glass-stoppered, of 50 ml capacity.

D-2 REAGENT

D-2.1 Methyl Red Indicator

Dissolve 0.50 g of water soluble methyl red in distilled water and dilute to 1 litre.

D-3 PROCEDURE

Take, 10 ml of freshly boiled and cooled distilled water in the graduated measuring cylinder. Add 2 drops of methyl red indicator and if necessary, adjust to the Neutral colour of the indicator. Add 10 ml of the material and shake well. Allow the layers to separate and examine the aqueous layer.

D-4 The material shall be considered as not showing any acid reaction if the colour of indicator does not change towards red.

ANNEX E

[Table 1, Sl No. (v)]

DETERMINATION OF HYDROGEN SULPHIDE, SULPHUR DIOXIDE AND OTHER REDUCING SUBSTANCES (*as* H₂S)

E-1 DETERMINATION OF HYDROGEN SULPHIDE CONTENT

E-1.1 Principle

Extraction of the hydrogen sulphide with a solution of zinc acetate. Formation of a coloured complex between the hydrogen sulphide and dimethyl-*p*-phenylenediamine. Photometric measurement of the colored complex at a wavelength of about 670 nm.

E-1.2 Apparatus

E-1.2.1 Spectrophotometer or Photoelectric Absorptiometer

E-1.3 Reagents

E-1.3.1 Zinc Acetate Dihydrate, 15 g/l in dilute acetic acid solution.

Dissolve 15 g of zinc acetate dihydrate [Zn(CH₃COO)₂·2H₂O] in water, add glacial acetic acid (approximately 17 N solution) until the solution is clear, dilute to 1 000 ml with water and mix.

E-1.3.2 Dimethyl-*p*-Phenylenediamine, 4 g/l solution in dilute hydrochloric acid.

Dissolve 0.4 g of dimethyl-*p*-phenylenediamine in 100 ml of approximately 6 N hydrochloric acid solution; shake with about 1 g of activated carbon and filter. Repeat the treatment with activated carbon until the filtrate becomes colourless.

E-1.3.3 Hydrogen Sulphide, standard solution corresponding to 5 mg of H₂S per litre.

Weigh, to the nearest 0.001 g, 0.882 g of sodium sulphide hydrate (Na₂S·9H₂O), dissolve in recently boiled and cooled water, dilute to the mark in a 1 000 ml one-mark volumetric flask and mix. Take 10.0 ml of the resultant solution, transfer it to a 250 ml one-mark volumetric flask, dilute to the mark with recently boiled and cooled water and mix. 1 ml of this standard solution corresponds to 0.005 mg of hydrogen sulphide (H₂S). Prepare the two solutions at the time of use.

NOTE — If necessary, check iodometrically the concentration of this solution.

E-1.3.4 Iron (III) Chloride, 2.5 g/l, solution in dilute hydrochloric acid.

Dissolve approximately 2.50 g of iron (III) chloride hydrate (FeCl₃·6H₂O) in 100 ml of approximately 6 N hydrochloric acid solution.

E-1.3.5 Carbon Disulphide, free from hydrogen sulphide

Vigorously shake recently distilled carbon disulphide with approximately 20 percent (v/v) of the zinc acetate solution (**E-1.3.1**). Separate the phases and distil the carbon disulphide phase on a water bath at 60 °C, discarding the first portions of the distillate.

E-1.4 Procedure

E-1.4.1 Test Portion

Take 10 ± 0.1 ml of the test sample (that is 12.6 g), containing 0.005 to 0.05 mg of hydrogen sulphide, and weigh this test portion to the nearest 0.01 g.

E-1.4.2 Blank Test

Carry out a blank test at the same time as the determination, following the same procedure and using the same quantities of all the reagents as those used for the determination.

E-1.4.3 Preparation of the Calibration Curve

E-1.4.3.1 Preparation of the standard matching solutions

Into a series of eight 100 ml separating funnels, pour the volumes of the standard hydrogen sulphide solution (E-1.3.3) and the carbon disulphide (E-1.3.5) indicated in Table 2.

Table 2 Volumes of the Standard Hydrogen Sulphide Solution and Carbon Disulphide
(Clause E-1.4.3.1)

Sl No.	Standard Hydrogen Sulphide Solution (E-1.2.3), ml	Corresponding Mass of Hydrogen Sulphide, mg	Carbon Disulphide (E-1.2.5), ml
(1)	(2)	(3)	(4)
i.	0 ¹⁾	0	0
ii.	0 ²⁾	0	10
iii.	1	0.005	10
iv.	2	0.010	10
v.	4	0.020	10
vi.	6	0.030	10
vii.	8	0.040	10
viii.	10	0.050	10

1) Matching test solution.
2) Compensation solution

E-1.4.3.2 Extraction of the hydrogen sulphide

To each of the separating funnels, add 25.0 ml of the zinc acetate solution (E-1.3.1) and shake vigorously for 5 min. Allow to stand, separate the two phases and transfer 20.0 ml of the aqueous phase to a 50 ml one-mark volumetric flask.

E-1.4.3.3 Colour development

Add 2 ml of the dimethyl-*p*-phenylenediamine solution (E-1.3.2) and 0.5 ml of the iron (III) chloride solution (E-1.3.4) and dilute to the mark. Mix and leave undisturbed for 20 min.

E-1.4.3.4 Photometric measurements

WARNING — The compensation solution²⁾ shall have an absorbance equal to that of the matching test solution¹⁾

Carry out the photometric measurements with the spectrophotometer (E-1.2.1), at a wavelength of about 670 nm, or the photoelectric absorptiometer (E-1.2.1), fitted with suitable filters, after

having adjusted the apparatus to zero absorbance against the matching test solution. Use a cell of optical path length suited to the characteristics of the measuring instrument.

E-1.4.3.5 Preparation of the calibration chart

Plot a graph having, for example, the number of milligrams of H₂S contained in 50 ml of the standard matching solutions as abscissae and the corresponding values of the absorbance as ordinates.

E-1.4.4 Determination

Transfer 25.0 ml of the zinc acetate solution (**E-1.3.1**) to a 100 ml separating funnel and add the test portion (**E-1.4.1**). Shake vigorously for 5 min. Allow to stand, separate the two phases and transfer 20.0 ml of the aqueous phase to a 50 ml one-mark volumetric flask. Proceed as described in **E-1.4.3.3** and **E-1.4.3.4**.

E-1.5 Expression of Results

By means of the calibration curve (**E-1.4.3.5**), determine the quantity of hydrogen sulphide corresponding to the value of the photometric measurements of the test solution.

The hydrogen sulphide content, expressed in ppm is given by the formula:

$$\text{Hydrogen Sulphide Content (H}_2\text{S), ppm} = \frac{m_3}{m_0} \times 1000 \times \frac{20}{25} = \frac{m_3}{m_0} \times 800$$

where

m_0 = mass of the test portion; in g; and

m_3 = mass of hydrogen sulphide found in the aliquor portion of the test solution, in mg.

E-2 DETERMINATION OF SULPHUR DIOXIDE + SULPHUR TRIOXIDE CONTENT

E-2.1 Principle

Separation of an aqueous extract of carbon disulphide. Turbidimetric measurement of the barium sulphate obtained by precipitation; under well-defined conditions, with barium chloride, of the water-soluble sulphur compounds, after oxidation with hydrogen peroxide.

E-2.2 Reagents

During the analysis, use only reagents of recognized analytical reagent grade and only distilled water or water of equivalent purity.

E-2.2.1 Barium Chloride Dihydrate

Standardized by screening, of uniform particle size ranging between 0.50 mm and 1.25 mm.

It is essential that all preparations concerning the determination and calibration should be carried out with a product having the same particle size distribution.

E-2.2.2 *Hydrogen Peroxide*, 35 percent (m/m) solution.

E-2.2.3 *Hydrochloric Acid*, approximately N solution.

E-2.2.4 *Sulphuric Acid*

Standard solution containing 100 mg of SO₄ per litre.

Transfer 20.8 ml of exactly 0.1 N sulphuric acid solution to a 1 000 ml one mark volumetric flask, dilute to the mark and mix. 1 ml of this standard solution contains 0.1 mg of SO₄.

E-2.3 Apparatus

Ordinary laboratory apparatus and

E-2.3.1 *Spectrophotometer or*

E-2.3.2 *Photometric Absorptiometer*

Fitted with filters giving only negligible transmission below 450 nm and above 550 nm.

E-2.4 Procedure

E-2.4.1 *Test Portion*

Take 10 ± 0.1 ml of the test sample (that is, 12.6 g), containing a mass of water-soluble sulphur compounds equivalent to 0.2 to 4 mg of SO₄. Weigh this test portion to the nearest 0.01 g.

E-2.4.2 *Blank Test*

Carry out a blank test at the same time as the determination, following the same procedure and using the same quantities of all the reagents as those used for the determination.

E-2.4.3 *Preparation of the calibration curve*

E-2.4.3.1 *Preparation of the standard matching solutions*

Into a series of ten 50 ml one-mark volumetric flasks, place the volumes of the standard sulphuric acid solution (**E-2.2.4**) indicated in Table 3.

Table 3 Volumes of the Standard Sulphuric Acid Solution
(Clause E-2.4.3.1)

Sl No.	Standard Sulphuric Acid Solution, ml	Corresponding Mass of SO ₄ , mg
(1)	(2)	(3)
i.	0 ¹⁾	0
ii.	2.0	0.2
iii.	5.0	0.5
iv.	10.0	1.0

v.	15.0	1.5
vi.	20.0	2.0
vii.	25.0	2.5
viii.	30.0	3.0
ix.	35.0	3.5
x.	40.0	4.0

¹⁾ Compensation solution

Add 5 ml of the hydrochloric acid solution (**E-2.2.3**) to each flask, stir, dilute to the mark and mix.

E-2.4.3.2 *Turbidimetric reaction*

Pour the contents of each volumetric flask rapidly into a dry 100 ml beaker containing approximately 0.3 g of the barium chloride (**E-2.2.1**). Stir by hand for 1 min at a rate of 2 rev/s. Leave undisturbed for 15 min at 20 ± 2 °C.

NOTE - Stegger the tests in such a way as to adhere to the contact times indicated.

E-2.4.3.3 *Turbidimetric measurements*

Stir the solution which is to be subjected to photometry by hand, transfer it to a cell of suitable optical path length and carry out the measurements with the aid of the spectrophotometer (**E-2.3.1**), at a wavelength of about 470 nm, or by means of the photoelectric absorptiometer (**E-2.3.2**), fitted with suitable filters, after having adjusted the instrument to zero absorbance against the compensation solution.

E-2.4.3.4 *Preparation of the calibration chart*

Plot a graph having, for example, the number of milligrams of SO₄ contained in 50 ml of the standard matching solutions as abscissae and the corresponding values of the absorbance as ordinates.

E-2.4.4 *Determination*

E-2.4.4.1 *Preparation of the test solution*

Place the test portion (**E-2.4.1**) and 25 ± 0.1 ml of water in a dry 100 ml separating funnel. Shake vigorously for 3 min.

Leave undisturbed until the phases have separated and transfer the aqueous phase to a dry vessel, filtering it through dry filter paper.

Pour 20 ± 0.1 ml of the filtered aqueous phase into a 50 ml one-mark volumetric flask, add 5 ml of the hydrogen peroxide solution (**E-2.2.2**) and 5 ml of the hydrochloric acid solution (**E-2.2.3**), shake, leave undisturbed for 10 min, dilute to the mark and mix.

E-2.4.4.2 *Turbidimetric reaction*

Take 25.0 ml of the test solution (E-2.4.4.1) and transfer it rapidly to a dry 100 ml beaker containing approximately 0.15 g of the barium chloride (E-2.2.1). Stir by hand for 1 min at a rate of 2 rev/s. At this point, the barium chloride should be completely in solution. Allow to stand for 15 min.

E-2.4.4.3 Turbidimetric measurement

Transfer a sufficient quantity of the test solution (E-2.4.4.1) to a cell of the same optical path length as that used for preparing the calibration curve (E-2.4.3) and use this solution as compensation solution for adjusting the spectrophotometer (E-2.3.1) or the photoelectric absorptiometer (E-2.3.2) to zero absorbance.

Stir the solution (E-2.4.4.2) by hand, transfer it to a cell of the same optical path length and proceed with the turbidimetric measurement by the method described in E-2.1.3.3.

E-2.5 Expression of Results

By means of the calibration curve (E-2.4.3.4), determine the quantity of SO₄ corresponding to the value of the turbidimetric measurements. The SO₂ and SO₃ content, expressed as milligrams of SO₄ per kilogram of product, is given by the formula:

$$\frac{m_4 - m_5}{m_6} \times 1000 \times \frac{20}{25} = \frac{m_4 - m_5}{m_6} \times 800$$

where

m_4 = mass of SO₄ found in the test solution; in ml

m_5 = mass of SO₄ found in the blank test solution; in ml and

m_6 = mass of the test portion, in g.

ANNEX F

[Table 1, Sl No. (v)]

DETERMINATION OF PURITY OF CARBON DISULPHIDE, TECHNICAL

F-1 The carbon disulphide, technical content shall be determined by the difference as given below:

Carbon Disulphide, percent by mass = 100 – {Residue on evaporation, percent by mass + [Hydrogen sulphide, sulphur dioxide and other reducing substances (as H₂S), percent by mass]}

ANNEX G

(Clause 6.1)

SAMPLING OF CARBON DISULPHIDE, TECHNICAL

G-1 GENERAL REQUIREMENT FOR SAMPLING

G-1.1 Samples shall be taken in a protected place not exposed to damp air, dust or soot.

G-1.2 The sampling instrument shall be clean and dry.

G-1.3 Precautions shall be taken to protect the samples, the material being sampled, the sampling instrument and the containers for samples from adventitious contamination.

G-1.4 To draw a representative sample, the contents of each container selected for sampling shall be mixed as thoroughly as possible by suitable means.

G-1.5 The sample shall be placed in suitable, clean, dry and airtight, glass bottles or other containers on which the material has no action.

G-1.6 The sample container shall be of such a size that they are almost three-fourths filled by the sample.

G-1.7 Each sample container shall be sealed airtight after filling and marked with full details of sampling, the date of sampling and the details given under **5.2**.

G-2 LOT

G-2.1 All the containers in a single consignment of the material drawn from a single batch of manufacture shall constitute a lot. If a consignment is declared to consist of different batches of manufacture, the batches shall be marked separately and the containers in each batch shall constitute a separate lot.

G-2.2 For ascertaining the conformity of the material in any lot to the requirements of this specification, samples shall be tested for each lot separately. The number of containers to be selected at random from lots of different sizes shall be in accordance with Table 4.

G-2.3 In order to ensure randomness of selection, the following procedure is recommended for use:

Arrange all the containers in the lot in a systematic manner, and starting from any one count them as 1, 2, . . . up to r and so on, where r is the integral part of N/n (N and n being the lot size and sample size respectively). Every r^{th} container thus counted shall be withdrawn to constitute the sample.

Table 4 Number of Containers to be selected from Lots of Different Sizes
(Clause G-2.2)

Lot Size N (1)	Sample Size n (2)
3 to 15	3
16 to 40	4
41 to 110	5
111 to 180	6
181 to 300	7

301 to 500	8
501 to 800	9
801 and above	10

G-3 COMPOSITE SAMPLE

G-3.1 From each of the containers selected according to **G-2.3**, a representative portion of the material from different parts of the container shall be drawn. From each of these individual portions, an equal quantity of the material shall be taken and thoroughly mixed to constitute a composite sample not less than 1 000 ml in volume. The composite sample shall be divided into three equal parts, one for the purchaser, another for the supplier and the third to be used as a referee sample. These shall be transferred to clean containers and labelled with full identification particulars of the sample.

G-4 TESTS

Tests for the determination of the characteristics given in **3.1** and Table 1 shall be carried out on the composite sample.

G-5 CRITERIA FOR CONFORMITY

For declaring the conformity of the lot to this specification, the test results on the composite sample shall meet the corresponding requirements specified in the standard.