

Draft Indian Standard
SPECIFICATION FOR STRUCTURAL WEATHER RESISTANT STEELS
(First Revision of IS 11587)

ICS 77.140.20

© BIS 2023
BUREAU OF INDIAN STANDARDS
MANAK BHAVAN, 9 BAHADUR SHAH ZAFAR MARG
NEW DELHI 110002

Wrought Steel Products Sectional Committee, MTD 4

FOREWORD

This Indian Standard (First Revision) was adopted by the Bureau of Indian Standards, after the draft finalized by Wrought Steel Products Sectional Committee had been approved by the Metallurgical Engineering Division Council.

This standard was first published in 1986. While reviewing the standard, in the light of experience gained during these years, the Committee decided to revise it to bring in line with those present practices being followed by the Indian industry.

The atmospheric corrosion resistance of these steels is approximately four times to that of carbon structural steel. Welding is of fundamental importance, and it is pre-supposed that suitable welding procedures will be adopted for welding the steels. These steels are intended for applications where weight saving along with improved atmospheric corrosion resistance is important.

The Indian Standards referred in this standard are subject to revision and parties to agreements based on this standard are encouraged to investigate the possibility of applying the most recent editions of the standards

In this revision the following changes have been made:

- i) Chemical and mechanical properties have been modified; Permissible Variation for Product Analysis also modified;
- ii) New grade designation system has been adopted; simultaneously old designations have also been given in Annex A;
- iii) New grades have been added;
- iv) Some of the Clauses are rearranged and modified; and
- v) Amendment No. 1 has been incorporated.

For all the tests specified in this standard (chemical/physical/others), the method as specified in relevant ISO Standard may also be followed as an alternate method.

In the formulation of this standard, due consideration has been given to the trade practices followed in the country in this field. Due consideration has also been given to international co-ordination among the standards prevailing in different countries:

<i>International Standard</i>	<i>Title</i>
ISO 630-5: 2014	Structural steels with improved atmospheric corrosion resistance
ISO 5952: 2019	Hot Rolled Structural quality with improved atmospheric corrosion resistance
DIN EN 10025-5: 2019	Structural steels with improved atmospheric corrosion resistance
ASTM A606: 2018	Hot-Rolled and Cold-Rolled, with Improved Atmospheric Corrosion Resistance
ASTM A709: 2021	Standard Specification for Structural Steel for Bridges
ASTM A871:2020	High-Strength Low-Alloy Structural Steel Plate with Atmospheric Corrosion Resistance
JIS G 3125: 2021	Superior atmospheric corrosion resisting rolled steels

The composition of the Committee responsible for the formulation of this standard is given in Annex B.

For the purpose of deciding whether a particular requirement of this standard is complied with, the final value, observed or calculated, expressing the result of a test or analysis, shall be rounded off in accordance with IS 2: 1960 'Rules for rounding off numerical values (revised). The number of significant places retained in the rounded off value should be the same as that of the specified value in this standard.

Draft Indian Standard

SPECIFICATION FOR STRUCTURAL WEATHER RESISTANT STEELS

(First Revision of IS 11587)

1 SCOPE

1.1 This standard covers the requirements for hot-rolled and cold-rolled structural weather resistant steels (flat and long products) in the form of plates, sheets, strips, sections, flats, bars and rods for welded, riveted or bolted construction requiring atmospheric corrosion resistance.

1.2 The grades in this standard except ISH310WR contain additional alloying elements and provide a level of corrosion resistance substantially better than that of carbon steels with or without copper addition. When properly exposed to the atmosphere, steel can be used bare (unpainted) for many applications.

1.3 ISH340WP available in 2 grades : Grade1 for sheets and plates (in flat or coil form): Intended for structural purposes where guaranteed mechanical properties, weldability and suitability for forming simple cold pressed parts are required. Grade2 for sheets, plates (in flat or coil form) and sections: Intended for general engineering purposes with guaranteed mechanical properties and weldability.

1.4 The guidelines for thicknesses in which products of the steel grades and qualities specified in this document can be supplied are given in Table A below. However, max thickness grade wise as per table 3A will be applicable.

Table A Product forms for the different steel grades with improved atmospheric corrosion resistance depending on their thickness

Designation	Flat products			Long products		
	Nominal thickness, mm			Nominal thickness or diameter, mm		
	≤ 16	≤ 100	≤ 200	Sections ≤ 63	Bars ≤ 150	Rods ≤ 60
ISH235WR, ISH245WR, ISH310WR, ISH345WR, ISH355WR, ISH365WR1, ISH365WR2			Yes	Yes	Yes	Yes
ISH245WP, ISH340WP, ISH355WP, ISH360WP	Yes			Yes		
ISH400WR, ISH415WR, ISH450WR, ISH460WR1, ISH460WR2, ISH500WR, ISH600WR, ISH700WR		Yes		Yes		

2 REFERENCES

The following standards contain provisions, which through reference in this text constitute provisions of this standard. At the time of publication, the editions indicated were valid. All standards are subject to revision and parties to agreements based on this standard are encouraged to investigate the possibility of applying the most recent editions of the standards indicated below:

<i>IS No.</i>	<i>Title</i>
IS 228(in various parts)	Methods of chemical analysis of steels
IS 808: 2021	Dimensions for hot rolled steel beam, channel and angle sections (<i>fourth revision</i>)
IS 1173: 1978	Specification for hot rolled and slit steel tee bars (<i>second revision</i>)
IS 1252:1991	Hot rolled steel bulb angles –Dimensions (<i>first revision</i>)
1599: 2019/ ISO 7438: 2016	Metallic materials – Bend test (<i>fourth revision</i>)
1608(Part 1): 2022/ ISO 6892-1: 2019	Metallic materials – Tensile testing - Part 1 Method of test at room temperature (<i>fifth revision</i>)
IS 1730: 1989	Steel plates, sheets, strips and flats for structural and general engineering purposes – Dimensions (<i>second revision</i>)
IS 1732:1989	Steel bars, round and square for structural and general engineering purposes – Dimensions (<i>second revision</i>)
1757(Part 1): 2020/ ISO 148-1: 2016	Metallic materials – Charpy pendulum impact test Part 1 Test method (<i>fourth revision</i>)
IS 1852:1985	Specification for rolling and cutting tolerances for hot rolled steel Products (<i>fourth revision</i>)
IS 1863:1979	Specification for rolled steel bulb flats (<i>first revision</i>)
IS 1956 (various parts)	Glossary of terms relating to iron and steel (<i>second revision</i>)
IS 2314:1986	Specification for steel sheet piling sections (<i>first revision</i>)
IS 3803 (Part 1): 1989	Steel – Conversion of elongation values: Part 1 Carbon and low alloy steels (<i>second revision</i>)
IS 3954:1991	Hot rolled steel channel sections for general engineering purposes – Dimensions (<i>first revision</i>)
IS 4923:2017	Hollow steel sections for structural use – Specification (<i>third revision</i>)
IS 8910: 2022/ ISO 404: 2013	General technical delivery requirements for steel and steel products (<i>second revision</i>)
IS 12779: 1989	Rolling and cutting tolerances for hot rolled parallel flange beam and column sections
IS 10842 (Part 2): 2019	Destructive Tests on Welds in Metallic Materials - Cold Cracking Tests for Weldments — Arc Welding Processes part 2 self-Restraint Tests (<i>first revision</i>)
IS 4225:2022/ ISO 17557:2016	Steel — Ultrasonic Testing of Steel Flat Products of Thickness Equal to or Greater than 6 mm
IS/ISO 16160: 2012	Hot-rolled steel sheet products — Dimensional and shape tolerances (<i>first revision</i>)
IS/ISO 16162: 2012	Cold-rolled steel sheet products — Dimensional and shape tolerances (<i>first revision</i>)
IS 4748:2021/ ISO 643:2019	Steels - Micrographic determination of the apparent grain size

3 TERMINOLOGY

For the purpose of this standard the definitions given in IS 1956 and the following definitions shall apply.

3.1 As-rolled — Delivery condition without any special rolling i.e. Conventional hot rolling without any normalized rolling or thermo-mechanical rolling and/or heat treatment like normalizing or quenching.

3.2 Normalizing Rolling — A hot rolling process in which the final deformation is carried out within a certain temperature range equivalent to normalizing temperature, leading to a material condition equivalent to that obtained after normalizing, such that the specified mechanical properties would still

be met in the event of any subsequent normalizing.

NOTE — In international publications for both the normalizing rolling, as well as the thermo-mechanical rolling, the expression "controlled rolling" may be found. However, in view of the different applicability of the products a distinction of the terms is necessary.

3.3 Normalized — Produced by heating to a suitable temperature above the transformation range (austenitizing) followed by air cooling.

3.4 Thermo-Mechanical Rolling — A hot rolling process in which the final deformation is carried out in a certain temperature range leading to a material condition with certain properties that cannot be achieved or repeated by heat treatment alone.

The term "Thermo-Mechanical Control Process" can also be used.

NOTES

- 1 Subsequent heating above 580 °C may lower the strength values.
- 2 Thermo-mechanical rolling can include processes with an increasing cooling rate with or without tempering including self-tempering but excluding direct quenching and quenching and tempering.
- 3 In some publications the word TMCP (Thermo-mechanical Control Process) is also used.

3.5 Steel with improved atmospheric corrosion resistance (Weather resistance steels) –

Steel in which a certain number of alloying elements, such as P, Cu, Cr, Ni, etc., have intentionally been added in order to increase its resistance to atmospheric corrosion, by forming an auto-protective oxide layer on the base metal under the influence of weather conditions; these steels are commonly known as 'weathering steels'.

4 SUPPLY OF MATERIALS

General requirements relating to the supply of material shall conform to IS 8910.

5 DESIGNATION AND GRADES

5.1 Weathering Steels covered by this standard shall be designated by their yield strength.

This standard specifies

- 19 steel grades are covered in Table 1A, 3A, 4 and 5 for hot rolled steel (designated by ISH) and
- 2 steel grades are covered in Table 1B, 3B and 4 for cold rolled steel (designated by ISC).

Grades are subdivided into classes WR and WP which differ primarily in their phosphorus contents; grades ISH365 and ISH460 are subdivided into classes WR1 and WR2 which differ primarily in alloying element requirements for Si, Cr, Cu, and Ni (*see* Table 1A).

Class WR denotes weathering steel has an improved atmospheric corrosion resistance; class WP denotes weathering steel with higher levels of phosphorus.

Each grade is available in up to four (4) qualities. These grades and qualities differ in their specified mechanical properties and impact energy requirements. The qualities on basis of impact energy requirements are as follows:

- Quality A: no impact testing
- Quality BR: impact testing at +20 °C
- Quality B0: impact testing at 0 °C
- Quality C and C1: impact testing at –20 °C

NOTE — Quality C1 specifies a higher minimum impact energy than C.

5.2 Application

Class A steels satisfy only moderate loading conditions (Applicable to ISH355WP).

Class B steels are intended for use in welded structures or structural parts, subjected to normal loading conditions (Applicable to ISH235WR, ISH245WR and ISH365WR1).

Class C steels are to be used in cases where, owing to loading conditions and the general design of the structure, some resistance to brittle fracture is necessary (Applicable to ISH355WR).

Class D steels are to be used for structures or structural parts where, owing to loading conditions and the general design of the structure, a high resistance to brittle fracture is necessary (Applicable to ISH235WR, ISH245WR, ISH355WR, ISH355WP and ISH365WR1).

5.3 Basis for order

While placing an order for the purchase of material covered by this standard, the purchaser should specify the following:

- a) Designation (Grade and Quality for Hot rolled steel. Grade for Cold rolled steel);
- b) Product Form (plate, section, bar, sheet or strip);
- c) Quantity (mass or number);
- d) Nominal dimensions - thickness, width and length (for cut lengths);
- e) Condition;
- f) Quality (A, BR, B0 and C or C1)

6 MANUFACTURE

6.1 The manufacturing process of the steel is left to the discretion of the manufacturer or as per agreement between manufacturer and purchaser. If required, secondary refining in the form of ladle refining, vacuum degassing may follow steel making.

6.2 The methods of deoxidation are designated as follows:

- FN - Rimming steel not permitted. This Option is applicable to Qualities A, BR and B0;
- FF - Fully killed steel containing nitrogen binding elements in amounts sufficient to bind the available nitrogen (for example, minimum 0.020 percent total aluminium). The usual guideline is minimum aluminium to nitrogen ratio of 2:1, when no other nitrogen binding elements are present. This Option shall be applicable to Qualities C and C1. On mutual agreement Qualities A, BR and B0 can be used this option.

6.3 The products may be rolled and supplied in as-rolled or normalized or normalizing rolling or controlled rolling or thermo-mechanical rolling and accelerated cooling conditions as per the agreement between the purchaser and the manufacturer/supplier.

6.4 The manufacturer can supply sheets, plates and sections either in hot rolled and if required in as skin passed or cold rolled and annealed condition only or hot rolled followed by cold finishing or cold rolled and annealed. In case of cold rolled finished supply, there shall, however, be no adverse effects on the properties of the product. The manufacturing process adopted for cold rolling/finishing shall be furnished by the supplier.

6.5 Hot rolled sheets and strips shall be descaled if so requested by the purchaser, using either acid pickling or shot blasting. Hot rolled and cold rolled Steel sheets and strips which have been descaled by acid pickling or shot blasting shall be oiled, if so requested by the purchaser.

6.6 Surface condition

Oxide or scale in hot-rolled steel sheet is subject to variations in thickness, adherence and colour. Removal of the oxide or scale by pickling or blast cleaning may disclose surface imperfections not readily visible prior to this operation.

6.7 Oiling

As a deterrent to rusting, a coating of oil is usually applied to hot-rolled, descaled steel sheet, but sheet may be furnished unoiled, if required. The oil is not intended as a forming lubricant and shall be easily removable with degreasing chemicals. When requested, the manufacturer shall advise the purchaser which type of oil has been used.

6.8 Corrosion resistance

The resistance of these steels to atmospheric corrosion is due to the formation of a protective oxide layer. The formation of this protective layer depends not only on chemical composition, such as the distinctive differences between the analyses of the various grades, but also on a number of factors such as surrounding atmosphere, design, etc., over which the steel producer has no control. See Annexes B and C for information on estimating the corrosion resistance and cautions concerning the use of these steels.

7 CHEMICAL COMPOSITION

7.1 Ladle Analysis

The ladle analysis or heat analysis of the steel, when carried out by the method specified in the relevant parts of IS 228 or any other established instrumental/chemical method, shall conform to the requirements as given in Table 1A and Table 1B. This analysis shall be made from a test sample, preferably taken during casting/teeming of the heat. In case of dispute, the procedure given in IS 228 and its relevant parts shall be the referee method and where test methods are not specified shall be as agreed to between the purchaser and the manufacturer/supplier. The ladle analysis shall be reported in the test certificate.

The ladle analysis shall be determined once per cast.

7.2 Product Analysis

The permissible variation in the case of product analysis from the limits specified in Table 1A and Table 1B shall be as given in Table 2.

7.2.1 If a product analysis has been agreed upon at the time of enquiry and order, the purchaser shall specify the frequency if not once per cast. The product analysis shall be carried out on the finished product from the standard position.

7.3 Carbon equivalent value (CEV)

Steel grades specified are of weldable quality. If agreed to between the manufacturer/supplier and the purchaser, the weather resistant steel up to and including 50 mm thick plates,

- for steel grade ISH235WR, a maximum carbon equivalent value of 0.44 %, and
- for steel grade ISH355WR, a maximum carbon equivalent value of 0.54 % based on heat analysis shall apply.

For other grades CEV may be mutually agreed between purchaser and supplier. The carbon equivalent value can be calculated using the formula:

$$\text{Carbon equivalent value (CEV)} = C + \frac{\text{Mn}}{6} + \frac{(\text{Cr} + \text{Mo})}{5} + \frac{(\text{Ni} + \text{C})}{15}$$

7.3.1 If the weather resistant steels are to be used unpainted, it is advisable to select the welding electrodes with matching weathering characteristics.

7.3.2 Lower limits for carbon equivalent values may be agreed to between the contracting parties.

7.3.3 Weldability

The steels specified in this document do not have unlimited suitability for the various welding processes, since the behavior of a steel during and after welding depends not only on the material but also on the dimensions and shape and on the manufacturing and service conditions of the components.

If filler metal without improved atmospheric corrosion resistance is used ensure that the weld itself is weather resistant.

Before welding, any surface layer which has already been formed should be removed to a distance of 10 mm to 20 mm from the joint edges.

General requirements for arc welding of the steels specified in this document shall be as given in IS 10842 part2.

For Grade ISH340WP and ISC300WP - The Plates and sections shall be suitable for gas and metal arc welding. The Sheets shall be suitable for gas and metal arc welding as well as suitable for spot and seam welding processes. Special precautions should be taken when welding steel grades of class WP with a high phosphorus content.

NOTES

1 With increasing product thickness and strength level cold cracking can occur. Cold cracking is caused by the following factors in combination:

- The amount of diffusible hydrogen in the weld metal;
- A brittle structure of the heat affected zone;
- Significant tensile stress concentrations in the welded joint.

2 Special precautions should be taken when welding grades ISH245WP, ISH340WP, ISH355WP, ISH360WP, ISC300WP and ISC315WP with a high phosphorous content.

3 In case of assembling by riveting and bolting, precautions should be taken with regard to the choice of rivets and bolts to be used for assemblies in order to prevent the start of the corrosion process.

Table 1A Chemical Composition for Hot Rolled Steel
(Clauses 5.1, 7.1 and 7.2)

Designation		Ladle Analysis, Percent, Max											
Grade	Quality	C	Si	Mn	P ^(b)	S ^(b)	N	Addition of "N" binding elements ^(c)	Cr	Cu	Ni	V	Others
ISH235WR	B0	0.13	0.40	0.20-0.60	0.035	0.035	0.009 ^(d,e)	-	0.40-0.80	0.25-0.55	0.65	-	
	C					0.030	-	Yes					
ISH245WR	A, BR, B0	0.18	0.15-0.65	1.25	0.035	0.035	-	Yes	0.45-0.75	0.30-0.50	0.05-0.30	-	
ISH245WP	A	0.15	0.10 min	0.55	0.06-0.16	0.040	-	-	0.24-1.31	0.20-0.60	0.20-0.70	-	
ISH310WR	A	0.22	-	1.25	-	0.040	-	-	-	0.20 min	0.65	-	
ISH340WP ^(h)	A	0.10	0.28-0.72	0.25-0.45	0.075-0.14	0.030	-	-	0.35-0.60	0.30-0.60	0.20-0.47	0.05	Mo-0.05, Nb-0.04, Al-0.08
ISH345WR	BR	0.23	0.40	0.50-1.60	0.035	0.045	-	-	0.35	0.60	0.45	0.15	Mo-0.15, Nb-0.05
ISH355WR ^(g)	A, BR, B0	0.19	0.15-0.50	0.50-1.50	0.035	0.035	0.009 ^(d,e)	-	0.40-0.80	0.25-0.55	0.65	0.10	Mo-0.30, Zr-0.15
	C, C1	0.16			0.030	0.030	-	Yes					
ISH355WP ^(g)	B0	0.12	0.20-0.75	0.60 ^(f)	0.070-0.15	0.035	0.009 ^(c)	-	0.30-1.25	0.25-0.55	0.65	-	
	C					0.030		Yes					
ISH360WP ^(g)	C	0.17	0.40	1.0	0.07-0.10	0.050	-	-	0.70-1.0	0.25-0.55	0.65	0.10	
ISH365WR1	A, BR, B0	0.18	0.15-0.65	1.40	0.035	0.035	-	Yes	0.45-0.75	0.30-0.50	0.05-0.30	-	
ISH365WR2	A, BR, B0	0.18	0.55	1.40	0.035	0.035	-	Yes	0.30-0.55	0.20-0.35	-	-	
ISH400WR	BR	0.15	0.15-0.55	2.00	0.020	0.006	0.006	Yes	0.45-0.75	0.30-0.50	0.05-0.30		
ISH415WR	B0, C, C1	0.20	0.15-0.50	0.50-1.35	0.040	0.050	-	Yes	0.30-0.70	0.20-0.50	0.50	0.01-0.10	Mo-0.10, Nb-0.05
ISH450WR	B0, C, C1	0.20	0.15-0.50	0.50-1.35	0.040	0.050	-	Yes	0.30-0.70	0.20-0.50	0.50	0.01-0.10	Mo-0.10, Nb-0.05
ISH460WR1	B0	0.18	0.15-0.65	1.40	0.035	0.035	-	Yes	0.45-0.75	0.30-0.50	0.05-0.30	-	
ISH460WR2	B0	0.18	0.55	1.40	0.035	0.035	-	Yes	0.30-0.55	0.20-0.35	-	-	
ISH500WR	B0	0.11	0.15-0.55	2.0	0.020	0.006	0.006	Yes	0.45-0.75	0.30-0.50	0.05-0.30	-	
ISH600WR	BR, B0	0.11	0.15-0.55	2.0	0.020	0.006	0.006	Yes	0.45-0.75	0.30-0.50	0.05-0.30	0.05	Mo-0.30, Nb-0.05
ISH700WR	C	0.11	0.15-0.55	2.0	0.015	0.006	0.006	Yes	0.45-1.20	0.30-1.50	0.05-2.0	0.05	Mo-0.60, B-0.005

a) When the steel is killed by aluminium the total aluminium content should not be less than 0.02 percent. When steel is silicon killed the silicon content shall not be less than 0.1 percent. When the steel is aluminium silicon killed the silicon content shall not be less than 0.03 percent and total aluminium content shall not be less than 0.01 percent. (see 6.2 for killing options).

b) For long products, the P and S content can be 0.005 percent higher.

c) The steel shall contain at least one of the following elements: At total ≥ 0.020 percent, Nb 0.015 percent to 0.060 percent, V: 0.02 percent to 0.15 percent, Ti: 0.02 percent to 0.10 percent. If these elements are used in combination, at least one of them shall be present with the minimum content indicated.

d) It is permissible to exceed the specified values provided that for each increase of 0.001 percent N, the maximum P content shall be reduced by 0.005 percent; the N content of the ladle analysis, however, shall not be more than 0.012 percent.

- e) The maximum value for nitrogen does not apply if the chemical composition shows a minimum total Al content of 0.020 percent, or if sufficient, other N binding elements are present. The N binding elements shall be mentioned in the inspection document.
- f) The upper limit of Mn may be 1.0 percent *Max* by agreement between the purchaser and the supplier.
- g) Chemical composition for thicknesses over 16 mm is subject to agreement between the manufacturer and the purchaser.
- h) Total incidental elements shall be 0.15 max
- i) Any element other than those listed in this table, which is added intentionally, shall be indicated to the purchaser.
- j) Restricted chemistry can be agreed mutually between purchaser and supplier.

Table 1B Chemical Composition for Cold Rolled Steel
(Clauses 5.1, 7.1 and 7.2)

Designation	Ladle Analysis, Percent, <i>Max</i>										
	Grade	C	Si	Mn	P	S	N	Cr	Cu	Ni	V
ISC300WP	0.10	0.28-0.72	0.25-0.45	0.075-0.14	0.030	-	0.35-0.60	0.30-0.60	0.20-0.47	0.05	Mo-0.05, Nb-0.04, Al-0.08
ISC315WP	0.12	0.20-0.75	0.60	0.070-0.15	0.035	0.009	0.30-1.25	0.25-0.55	0.65	-	

Table 2 Permissible Variation for Product Analysis
(Clause 7.2)

Element	Range of specified element, Percent	Permissible Variation Over/Under the Specified Limit, Percent, <i>Max</i>
Carbon	≤ 0.15	0.03 ^b
	$>0.15 \leq 0.22$	0.04
Silicon	≤ 0.80	0.06 ^b
Manganese	≤ 2.00	0.10 ^b
Phosphorus	≤ 0.04	0.01 ^b
	Over 0.04 to 0.15	^a
Sulfur	≤ 0.05	0.01 ^b
Vanadium	≤ 0.10	0.01
	$>0.10 \leq 0.25$	0.02
Niobium	≤ 0.06	0.01
Titanium	≤ 0.15	0.01
Copper	≤ 1.00	0.03
	Over 1.00 to 1.20	0.05
Nickel	≤ 1.00	0.03
	$>1.00 \leq 1.50$	0.05
Chromium	≤ 0.90	0.04
	$>0.90 \leq 2.00$	0.06
Molybdenum	≤ 0.20	0.01
	$>0.20 \leq 0.40$	0.03
	$>0.40 \leq 0.65$	0.04
Nitrogen	≤ 0.030	0.005
Boron	≤ 0.006	0.001

a) Product analysis not applicable.

b) For ISH340WP - Carbon: Permissible Variation Over the Specified Limit, 0.02 % max.

- Manganese: Permissible Variation Over/Under the Specified Limit, 0.05 % max.
- Silicon: Permissible Variation Over/Under the Specified Limit, 0.03 % max.
- Sulfur: Permissible Variation Over/Under the Specified Limit, 0.005 % max.
- Phosphorus: Permissible Variation Over/Under the Specified Limit, 0.005 % max.

8. SELECTION AND PREPARATION OF TEST SAMPLES

8.1 The position from which test samples are taken shall be so located in the product as to yield the clearest possible information regarding properties in the cross-sectional and longitudinal planes. The recommended locations for taking test samples for plates, sheets, strips, sections, flats, bars and rods are indicated in Fig. 1. Selection of location of test pieces may also be mutually agreed to between the purchaser and the manufacturer/supplier.

The sampling position of test piece shall be at a quarter-width from the edge of the sheet, strip and plate. If this is infeasible, the sampling should be made as close to the aforementioned position as possible. Tensile and bend test piece direction shall be as per below table.

<i>Class of Steel Product</i>	<i>Direction of Test Piece</i>
Plates, Sheets and Strips	Crosswise (Transverse)
Sections	Lengthwise for each type
Flats, bars (round hexagonal, etc.) and rods	Lengthwise

Alternative test piece direction may also be mutually agreed to between the purchaser and the manufacturer/supplier.

8.2 Wherever practicable, the rolled surface of the steel shall be retained on the two opposite sides of the test samples.

8.3 In case of flat test samples for tensile test, both surfaces are normally to be left on the test specimen for sheets, strips, and plate up to 32 mm thick. At least one rolled surface shall be left on rectangular test samples taken from plate more than 32 mm thick. Round test samples are permitted, but should only be adopted for thickness exceeding 20 mm.

8.4 In case of flats up to 16 mm thick, the test sample shall undergo, if possible, no machining whatsoever prior to use as a test piece. If this is not possible, the test sample shall undergo the minimum amount of machining.

8.5 Bars below 28mm and rods shall be tested without machining. In case of bars having diameters or thicknesses between 28 and 71 mm, the bars may be symmetrically reduced by machining. For bars having diameters or thicknesses exceeding 71 mm, the test sample may be taken from the position shown in Fig. 1.

8.6 In the case of plates, sheets, strips, sections, flats, and bars, bend tests are to be carried out on rectangular test samples which, as far as possible, should be of the full thickness of the product. In the case of sections, flats and plates exceeding 28 mm in thickness, it is permissible to remove metal from one side of the test sample before using it as a test piece. The rolled surface of the test piece shall be on the outer side of the bend during the test.

8.7 Test samples shall be cut in such a manner that deformation is avoided as far as possible. If shearing or flame-cutting is employed, an adequate allowance shall be left for removal by machining.

8.8 Test samples taken from rolled steel which have undergone deformation through bending or twisting shall in all cases be straightened cold. If the deformation is too severe to allow cold straightening, it is permissible in the case of materials to be delivered in the annealed or normalized condition, to carry out straightening under the application of heat, provided the temperature does not exceed 650°C. While straightening test samples, care shall be taken to avoid any cold-working or temperature rise which will alter the properties of the samples as

compared with the finished product which they represent.

8.9 Test samples shall not be subjected to heat treatment unless the material from which they are cut is similarly and simultaneously treated with the material before testing. Any slight straightening of test samples which may be required shall be done cold.

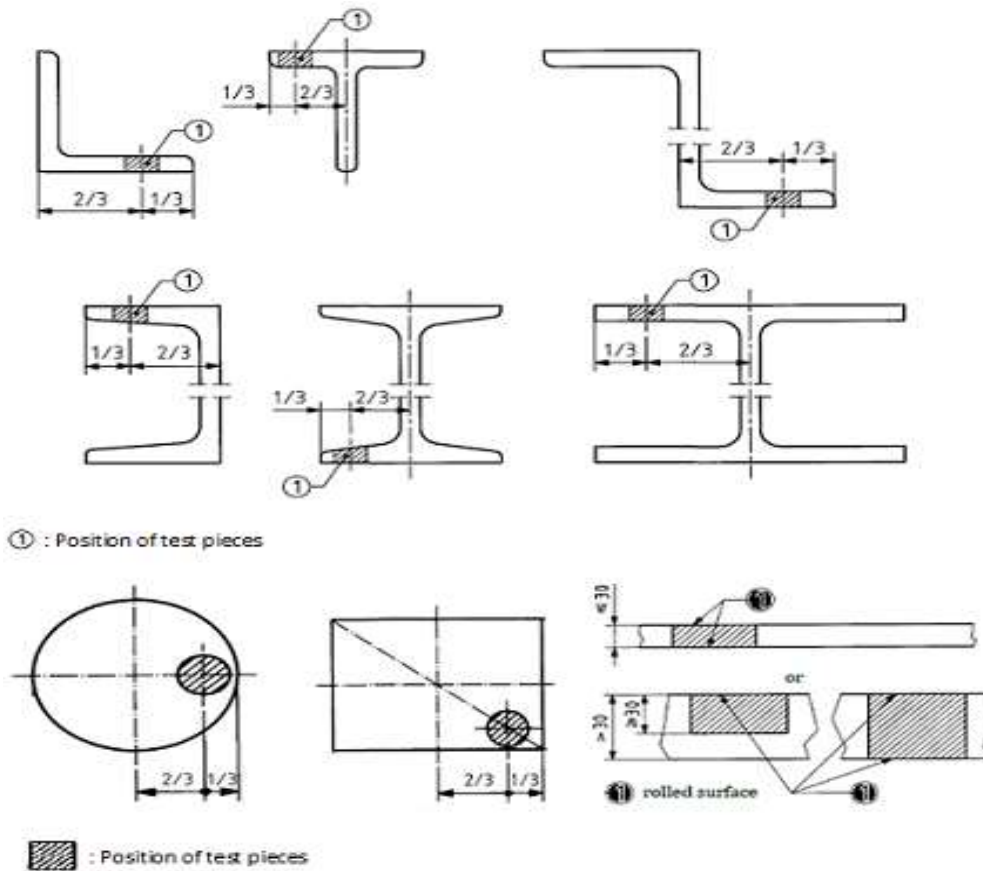

FIG. 1 STRUCTURAL STEEL SECTIONS, POSITION AND ORIENTATION OF SAMPLE

9 MECHANICAL PROPERTIES

9.1 Tensile Test

Yield strength, tensile strength and percentage elongation, when determined in accordance with IS 1608 (Part 1), shall conform to the requirements as given in Table 3A and Table 3B.

For the specified yield strength, the upper yield strength (R_{eH}) shall be determined. If a yield phenomenon is not present, the 0.2% proof strength ($R_{p0.2}$) shall be determined.

9.1.1 In case of sections, the thickness of which is not uniform throughout the profile, the limits of sizes given in Table 3A shall be applied according to the actual maximum thickness of the piece adopted for testing.

9.1.2 Should a tensile test piece break outside the middle half of the gauge length (*see* IS 1608 (Part 1)) and the percentage elongation obtained is less than that specified, the test may be

discarded at the manufacturer/supplier's option and another test made from the sample sheet, plate, strip, section, flat, bar or rod.

9.1.3 Number of Tensile Tests

Hot rolled steel - Number of test samples shall be 2 from each cast/heat and same form, grade, quality and delivery condition irrespective of cast/heat size.

Cold-rolled steel - Take one tensile from each lot of steel sheets/strips of the same heat, the same thickness, the same rolling condition. If the lot exceeds 50 t in mass, take additional tensile test pieces for every 50t.

9.1.4 Tensile Test Pieces

The tensile strength, yield strength and percentage elongation of steel shall be determined from standard test pieces. The test shall be carried out as on the standard test pieces prepared in accordance with IS 1608 (Part 1).

9.1.4.1 Test pieces with a non-proportional gauge length, other than $5.65\sqrt{S_0}$ may be used in which case the elongation values shall be converted to $5.65\sqrt{S_0}$ in accordance with IS 3803 (Part 1).

9.2 BENDTEST

Bend test shall be conducted in accordance with IS 1599.

For bend test, the test piece at room temperature shall withstand bend through 180° to an internal diameter not greater than that given in Table 4 without cracking.

For grade ISC315WP, bend test is optional and shall be performed only when specified by the purchaser. For this the bend test piece shall be 15 mm to 50 mm in width, and have an appropriate length which is about twice the width. The test piece shall be bent manually with a vise through 180° along the length direction of the test piece as shown in Fig. 2 with an internal spacing of $1t$. If bending with a vise is not possible, other suitable means of bending may be used.

9.2.1 Number of Bend Test

Hot rolled steel - Number of test samples shall be 2 from each cast/heat and same form, grade, quality and delivery condition irrespective of cast/heat size.

Cold-rolled steel - Take one sample from each lot of steel sheets/strips of the same heat, the same thickness, the same rolling condition. If the lot exceeds 50 t in mass, take additional tensile test pieces for every 50t.

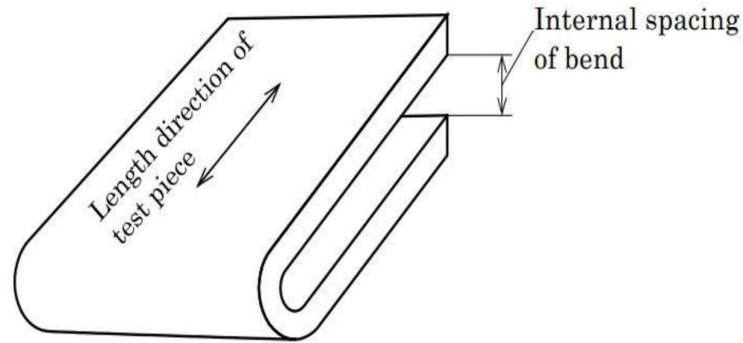

FIG. 2 DIRECTION OF BEND TEST

9.2.2 Bend Test Pieces

When sections permit, these shall be not less than 40 mm wide. If the manufacturer/supplier so desires, round, square, hexagonal and flat bars and structural sections shall be bent in the full section as rolled.

9.2.2.1 In all bend test pieces, the rough edges arising as a result of shearing may be removed by filing or grinding or machining, but the test pieces shall receive no other preparation.

9.2.2.2 The test pieces shall not be annealed or otherwise subjected to heat treatment unless the material from which they are cut is similarly treated, in which case the test pieces shall be similarly treated with the material, before testing.

9.3 IMPACT TEST

9.3.1 The impact test on V notched test pieces shall be carried out in accordance with IS 1757-1. The impact properties of Charpy V-notch test pieces shall comply with the values specified in Table 5. The orientation of the specimens shall be longitudinal unless transverse orientation is agreed between purchaser and manufacturer.

The impact properties of steel grade ISH class WP are verified only when specified at the time of the order.

For grades with quality C and C1 contained in Table 5 with nominal thickness < 6 mm, the ferritic grain size shall be ≥ 6 , verified by the method as described in IS 4748, if specified at the time of the order.

9.3.2 Impact test shall normally be carried out on products having thickness/diameter greater than or equal to 12 mm. For nominal thicknesses $12 < t < 40$ mm, standard 10 mm x 10 mm test pieces shall be machined in such a way that one side is not further away than 2 mm from a rolled surface, for nominal thicknesses ≥ 40 mm impact test pieces shall be taken from 1/4 t position. The notch axis shall be perpendicular to the rolled surface.

9.3.3 In the case of nominal product thickness $6 \text{ mm} \leq t \leq 12 \text{ mm}$, sub-sized test pieces shall be machined. The largest possible standard sub-sized test piece (7.5 mm or 5.0 mm) shall be used. The notch shall be perpendicular to the surface of the product. Where sub-sized test pieces are used, the minimum impact energy values given in Table 5 shall be reduced in proportion to the cross-sectional area of the test piece.

9.3.4 Impact tests shall not be required for nominal thickness $t < 6$ mm.

9.3.5 The test sample shall be taken from the thickest product. One test sample shall be taken from thickest product per cast/heat. If the test sample taken from the thickest product rolled from a cast meets the requirements, the whole cast shall be deemed to meet the requirements of the test, if not, the test shall be performed on a product of next lower thickness rolled from same cast, if it meets the requirements specified, this particular thickness as also other sections of lower thickness shall be deemed to satisfy this specification. If this thickness also does not meet the requirements, the test shall be carried out on the next lower thickness and so on, because the toughness of the product will be dependent on the rolling direction as well as on the product size.

9.3.6 The minimum impact values given in Table-5 apply for the mean of three test pieces. One individual value may be lower than the specified value, provided that it is not less than 70 % of the specified value.

Three additional test pieces shall be taken from the same sample in accordance with 9.3.5 and tested in any one of the following cases:

- if the average of three impact values is lower than the minimum average value specified;
- if the average value meets the specified requirement, but two individual values are lower than the minimum average value specified;
- if any one value is lower than 70 % of the minimum average value specified.

The average value of the six tests shall be not less than the minimum average value specified. Not more than two of the individual values may be lower than the minimum average value specified and not more than one may be lower than 70 % of this value.

9.3.7 Impact test at different temperatures and grades other than specified in Table 5 may be mutually agreed between the purchaser and the manufacturer/supplier accordingly the impact test values may be mutually agreed between the purchaser and the manufacturer/supplier.

10 FLATTENING TEST

10.1 Flattening test shall be carried out for circular hollow section if specified at the time of enquiry or order. If agreed upon between the manufacturer/supplier and the purchaser, this test may also be carried out on rectangular hollow sections.

10.2 A ring not less than 40 mm in length shall be cut for every 40 tonnes or part thereof and the inner and outer edges of the ring shall be rounded off.

10.3 The ring shall be flattened cold between the parallel plates with the weld, if any, at 45° in accordance with IS 2328. No opening shall occur by fracture in the weld until the distance between the plates is less than 75 percent of the original outside diameter. The test shall continue until the weld, if any, opens and the weld shall show no sign of incomplete fusion. No crack or breakage in the metal elsewhere than the weld shall occur until the distance between the plates is 2/3 of the original outside diameter.

Table 3A – Tensile properties at room temperature for hot rolled steel
(Clauses 5.1, 9.1 and 9.1.1)

Grade	Quality	Minimum yield strength, R_{eH}^a MPa						Minimum Tensile strength, R_m^a MPa			Position of test pieces ^a	Minimum percentage elongation after fracture ^{a, b, c} , Percent Nominal thickness ^d , mm								
		Nominal thickness ^d , mm						Nominal thickness ^d , mm				$L_0 =$ 50mm	$L_0 =$ 200mm	$L_0 = 80$ mm			$L_0 = 5.65 \sqrt{S_0}$			
		≤16	> 16 ≤ 40	> 40 ≤ 63	> 63 ≤ 100	> 100 ≤ 150	> 150 ≤ 200	< 3	≥ 3 ≤ 100	>100 ≤150				>1.5 ≤ 2.0	> 2.0 ≤ 2.5	> 2.5 < 3.0	≥ 3 ≤ 40	> 40 ≤ 63	> 63 ≤ 100	> 100 ≤150
ISH235WR	B0, C	235	225	215	215	195	-	360- 510	360- 510	350- 500	l t	-	-	19 17	20 18	21 19	26 24	25 23	24 22	22 22
ISH245WR	A, BR, B0	245	235	215	215	205 t>125 : 195	195	410- 540	410-540	410- 540 ^h	t	23	17	-	-	-	18 ⁱ	18	18	18
ISH245WP	A	245	235	-	-	-	-	410	410	-	t	25	-	-	-	-	-	-	-	-
ISH310WR	A	310	300	-	-	-	-	450	450	-	l	22	-	-	-	-	-	-	-	-
ISH340WP	A	t≤12.5 : 340	-	-	-	-	-	480 min	t≤12.5: 480 min	-	t	-	-	-	-	-	t≤12. 5: 22 ⁱ	-	-	-
ISH345WR	A, BR	345	345	345	345	-	-	450	450	-	t	21	18	-	-	-	-	-	-	-
ISH355WR	B0, C, C1	355	345	335	325 t>80: 315	295	-	510- 680	470-630	450- 600	l t	-	-	16 14	17 15	18 16	22 20	21 19	20 18	18 18
ISH355WP	B0, C	355	345	-	-	-	-	490 ^e	t≤16: 490 t>16: 470-630 ^f	-	l t	- t≤6: 22	- 6<t≤16: 15	16 14	17 15	18 16	22 ^f 20 ^g	- -	- -	- -
ISH360WP	C	t≤12: 355	-	-	-	-	-	500	t≤12: 500	-	t	-	-	-	-	-	t ≤12:2 0 ⁱ	-	-	-
ISH365WR 1	A, BR, B0	365	355	335	325	305 t>125 : 295	295	490- 610	490-610	490- 610 ^h	t	21	15	-	-	-	17 ⁱ	17	17	17
ISH365WR 2	A, BR, B0	365	355	335	325	305 t>125 : 295	295	490- 610	490-610	490- 610 ^h	t	21	15	-	-	-	17 ⁱ	17	17	17
ISH400WR	BR	400	400	400	400	-	-	490- 640	490-640	-	t	21	15	-	-	-	17 ⁱ	17	17	-
ISH415WR	B0, C, C1	415	415	390	-	-	-	520	t≤40:	-	l	-	-	15	15	15	19	18	-	-

								520		t	15	13	13	13	13	17	16	-	-	
ISH450WR	B0, C, C1	450	450	430	-	-	-	550	t≤40: 550	-	l	-	-	14	14	14	17	16	-	-
										t	14	12	12	12	12	15	14	-	-	
ISH460WR 1	B0	460	450	430	420	-	-	570- 720	570-720	-	t	20	-	-	-	-	16 ⁱ	16	16	-
ISH460WR 2	B0	460	450	430	420	-	-	570- 720	570-720	-	t	20	-	-	-	-	16 ⁱ	16	16	-
ISH500WR	B0	500	500	500	500	-	-	570- 720	570-720	-	t	20	-	-	-	-	16 ⁱ	16	16	-
ISH600WR	BR, B0	600	600	600	600	-	-	700	690	-	t	16	-	-	-	-	14 ⁱ	14	14	-
ISH700WR	C	700	700	700	-	-	-	780- 930	t≤63: 780-930	-	t	16	-	-	-	-	14 ⁱ	14	-	-

Notes

1 MPa = 1 N/mm².

a) For plate and wide flats with widths ≥ 600 mm, the direction transverse (t) to the rolling direction applies. For all other products, the values apply for the direction parallel (l) to the rolling direction.

b) For thicknesses up to 3 mm, use either $L_0 = 50$ mm or $L_0 = 80$ mm. For thicknesses of 3 mm inclusive to 6 mm inclusive, use $L_0 = 5.65 \sqrt{S_0}$, or $L_0 = 50$ mm. For thickness over 6 mm, use $L_0 = 5.65 \sqrt{S_0}$ or $L_0 = 200$ mm. In case of dispute, however, only the results obtained on a proportional test piece will be valid for material 3 mm and over in thickness.

Unless specified on the order, the manufacturer may use either a proportional or fixed gage length specimen. When the test value is reported, the specimen used shall be reported.

c) For plate, applicable up to 12 mm; for wide flats, bars, and sections, applicable up to 40 mm.

d) Manufacturer should be contacted for possible thickness limits (see clause 1.4).

e) For ISH355WP steel sheet and strip of under 3 mm in thickness, the tensile strength of 510 N/mm² or over is applicable by agreement between the purchaser and the manufacturer.

f) For plate, applicable up to 12 mm; for wide flats, bars, and sections, applicable up to 40 mm.

g) For ISH355WP grade, minimum Elongation 21% agreement between the purchaser and the manufacturer. In this case Yield Strength shall be 345Mpa minimum for $t \leq 12$ mm, 325Mpa minimum for t 12-40mm and Tensile strength shall be 480Mpa minimum for $t \leq 40$ mm.

h) The given tensile strength values shall be applicable up to 200mm thickness also.

i) The given elongation values shall be applicable for thickness < 3 mm also.

Table 3B – Tensile properties at room temperature for cold rolled steel
(Clauses 5.1 and 9.1)

Grade	Yield Strength, R _{eH} , Min MPa ⁵⁾	Tensile Strength R _m , Min MPa ⁵⁾	Percentage Elongation At Gauge Length 5.65√S ₀ , Min	Percentage Elongation At Gauge Length 50mm, Min
ISC300WP	300	440	26	-
ISC315WP*	315	450	-	26 ^a

Notes1 MPa = 1 N/mm².

* Applicable thickness 0.6 to 2.3mm

a) Other values may also be applied subject to mutual agreement between manufacturer and purchaser.

Table 4 – Bend Test
(Clauses 5.1 and 9.2)

Grade	Internal Bend Diameter, Max Nominal thickness, mm	Inside Radius, Max Nominal thickness, mm	
	t ≤ 25	t ≤ 6	t > 6-16
ISC300WP	1t	-	-
ISC315WP	1t	-	-
ISH310WR	-	2.5t ^c	-
ISH340WP	t ≤ 12.7: 1t	-	-
ISH355WR	3t ^a	-	-
ISH355WP	3t ^a	0.5t ^b	1.5t
ISH360WP	3t ^a	-	-

Notes**‘t’ is the thickness/diameter of the test piece**

- a) Round bars 25 mm and under internal bend diameter shall be 2t. Round bars >25 mm internal bend diameter shall be 3t.
b) For ISH355WP steel sheet and strip of 6.0 mm or under in thickness, the inside radius of 1.0 times the thickness is applicable by agreement between the purchaser and the manufacturer.
c) On agreement the suggested radii should be used as minimums for 90° bends in actual shop practice

11 INTERNAL SOUNDNESS

Ultrasonic testing may be agreed upon at the time of the order. If specified at the time of the order, ultrasonic testing shall be carried out for flat products in nominal thicknesses ≥ 6 mm, except for hot rolled strip and plate cut from strip in accordance with IS 4225.

For sections and bars, test methods and acceptance criteria may be mutually agreed between the purchaser and the manufacturer/supplier.

12 RETEST

12.1 If a test does not give the specified results, two additional tests shall be carried out at random on the same lot. Both retests shall conform to the requirements of this standard; otherwise, the lot shall be rejected.

12.2 Re-heat Treatment

If any heat-treated material fails to meet the mechanical requirements specified, the supplier may re-heat treat the material and, in that case, all mechanical properties shall be re-evaluated.

Table 5—Longitudinal Charpy V-notch properties ^a
(Clauses 5.1, 9.3.1, 9.3.3, 9.3.6 and 9.3.7)

Designation		Minimum impact energy, J, at test temperature, °C			
Grade	Quality	RT ^b	0	- 20	-30
ISH235WR	B0	-	27	-	-
	C	-	-	27	-
ISH245WR	BR	27	-	-	-
	B0	-	27	-	-
ISH345WR	C	-	-	27	-
	BR	27	-	-	-
ISH355WR	B0	-	27	-	-
	C	-	-	27	-
	C1	-	-	40	27
ISH355WP	B0	-	27	-	-
	C	-	-	27	-
ISH360WP	C	-	-	27	-
ISH365WR1	BR	27	-	-	-
ISH365WR2	B0	-	27	-	-
ISH400WR	BR	27	-	-	-
ISH415WR ISH450WR	B0	-	27	-	-
	C	-	-	20 ^c	-
	C1	-	-	-	20 ^d
ISH460WR1 ISH460WR2 ISH500WR	B0	-	27	-	-
ISH600WR	BR	27	-	-	-
	B0	-	27	-	-
ISH700WR	C	-	-	27	-

a) For nominal thicknesses ≤ 12 mm, Where sub-sized test pieces are used (see 9.3.3), the minimum impact energy values given shall be reduced in proportion to the cross-sectional area of the test piece.

b) RT = Room Temperature

c) Thickness ≤ 12 mm and 27J min can be agreed

d) Thickness > 12 mm and 27J min can be agreed

13 FREEDOM FROM DEFECTS

13.1 All finished steel shall be well and cleanly rolled to the dimensions, sections and masses specified. The finished material shall be reasonably free from surface flaws; laminations; rough/jagged and imperfect edges and all other harmful defects.

13.2 Minor surface defects may be removed by the manufacturer/supplier by grinding provided the thickness is not reduced locally by more than 4 percent below the minimum specified thickness. Reduction in thickness by grinding greater than 4 percent but not exceeding 7 percent may be made subject to mutual agreement between the purchaser and the manufacturer/supplier.

13.2.1 Subject to agreement with the purchaser, surface defects which cannot be dealt with as in **13.2** may be repaired by chipping or grinding followed by welding and inspection by a mutually agreed procedure such that,

- a) after complete removal of the defects and before welding, the thickness of the item is in no place reduced by more than 20 percent;
- b) welding is carried out by approved procedure by competent operators with approved electrodes and that the welding is ground smooth to the correct nominal thickness; and
- c) subsequent to the finish grinding, the item may be required to be normalized or otherwise heat-treated at the purchaser's discretion.

14 DIMENSIONS AND TOLERANCES

14.1 Unless otherwise agreed to between the purchaser and the manufacturer, the nominal dimensions of rolled steel products conforming to this specification shall be in accordance with the relevant Indian Standards. Currently available Indian Standards are listed in Table 6.

Table 6 Indian Standards which give nominal dimensions of rolled steel products
(Clause 14.1)

SI No	PRODUCT	RELEVANT INDIAN STANDARD
i)	Beam, column, channel and angle sections including parallel beam and column sections	IS 808
ii)	Tee bars	IS1173
iii)	Bulb angles	IS 1252
iv)	Plates, sheet and strip	IS 1730
v)	Flats	IS 1731
vi)	Round and square bars	IS 1732
vii)	Bulb flats	IS 1863
viii)	Sheet, piling sections	IS 2314
ix)	Channel sections	IS 3954
x)	Hollow sections	IS 4923

14.2 Unless otherwise agreed to between the purchaser and the manufacturer/supplier, the rolling and cutting tolerances for steel products conforming to this standard shall be those specified in IS 1852 or IS/ISO 16160 for hot rolled steel sheet, strip and sections, IS 12779 for Parallel beam and column section and IS/ISO 16162 for cold rolled sheet and strip. Other tolerances may be followed within the total tolerance range as specified in IS 1852, IS/ISO 16162 and IS 12779 as applicable.

15 CALCULATION OF MASS

Material shall be supplied on the basis of actual weight. If weighing is not possible, the mass of the steel shall be calculated on the basis of steel density 7.85 g/cm³.

16 DELIVERY

Subject to prior agreement between the manufacturer and the purchaser, a suitable protective treatment may be given to the material after rolling.

16.1 Conditions of Delivery

The products covered by this specification are delivered in the as-rolled, normalized-rolled, normalized and thermo-mechanical processed condition. Delivery condition shall be mutually agreed between the purchaser and the manufacturer/supplier.

17 MARKING AND PACKING

17.1 Plates, sheets, sections, bars and flats may be supplied in bundles, and strips and rods either in bundles or coils. Each bundle/coil shall carry a tag or label/sticker bearing the cast number or identification mark or lot number traceable to the cast number and the manufacturer's name or trade mark. Alternatively, top sheet/plate or strips in each bundle shall be legibly marked with the cast number or identification mark or lot number traceable to the cast number, name of the manufacturer or trade mark.

17.2 Unless otherwise agreed the packing shall be adequate to ship the material safely and in good condition.

17.3 BIS Certification Marking

The material may also be marked with Standard Mark.

17.3.1 The product (s) conforming to the requirements of this standard may be certified as per the conformity assessment schemes under the provisions of the *Bureau of Indian Standards Act, 2016* and the Rules and Regulations framed there under, and the products may be marked with the Standard Mark.

ANNEX A
(Informative)
(Foreword)

Mapping of old Grade and new grade designation system is as follows:

S. No.	New Grade	Old Grade
1	ISH355WP	WR-Fe 480A and WR-Fe 490H
2	ISH355WR	WR-Fe 480B
3	ISH360WP	WR-Fe 500
4	ISC315WP	WR-Fe 490C

Mapping of Grades with possible other specifications for reference:

BIS Grade	BIS 11587	IRSM 41/97	JIS 3125	ISO 630-5	ISO 5952	EN 10025-5	ASTM	
	Grade	Grade	Grade	Grade	Grade	Grade	Specification	Grade
ISH 235WR				S235W	HSA235W	S235J0W S235J2W		
ISH 245WR				SG245W1	HSA245W			
ISH 245WP							ASTM A423	Gr1
ISH310WR							ASTM A606	Type 2 & Type 4
ISH345 WR							ASTM A709	Gr50(345) & Gr50S
ISH 340WP		Grade1 & Grade2						
ISH355WR	WR-Fe480B			S355W	HSA355W2	S355J0W S355J2W S355K2W		
ISH355WP	WR-Fe480A WR-Fe490H		SPA-H	S355WP	HSA355W1			
ISH 360WP	WR-Fe500							
ISH 365WR1				SG365W1	HSA365W			
ISH 365WR2				SG365W2				
ISH400WR				SG400W				
ISH 415WR						S420J0W S420J2W	ASTM A871	Gr60
ISH 450WR						S460J0W S460J2W	ASTM A871	Gr65
ISH 460WR1				SG460W1				
ISH 460WR2				SG460W2				
ISH 500WR				SG500W				
ISH 600WR							ASTM A709	
ISH 700WR				SG700W				
ISC 300WP		Grade1						
ISC 315WP	WR-Fe490C		SPA-C				ASTM A606	Type 2

ANNEX B
(Informative)
**GUIDELINES FOR ESTIMATING THE ATMOSPHERIC CORROSION
RESISTANCE OF LOW-ALLOY STEELS**

B-1 GENERAL

This annex presents a method for estimating the atmospheric corrosion resistance of low-alloy weather-resistant steels from chemical composition data.

The method utilizes predictive formulae based on the steel composition to calculate indices of atmospheric corrosion resistance.

As many indices have been used around the world, it is necessary to consider the different environments and the chemical composition of the steel when choosing an index. As any index may be inappropriate based on the above, it is necessary for the purchaser and supplier to decide on the type of index to use and the requirement levels of that index for the expected environment.

B-2 TERMINOLOGY

Low-alloy steels mean iron-carbon alloys containing greater than 1 % but less than 5 %, by mass, of total alloying elements.

NOTE Most “low-alloy weather-resistant steels” contain additions of both chromium and copper, and can also contain additions of silicon, nickel, phosphorus, or other alloying elements which enhance atmospheric corrosion resistance.

B-3 PROCEDURE

B-3.1 Formulae for predicting the corrosion penetration of low-alloy steels after 15.5 years of exposure to various atmospheres, based on the chemical composition of the steel, were published by Legault and Leckie. The formulae are based on extensive data published by Larrabee and Coburn.

B-3.2 For use with these guidelines, the Legault-Leckie formula for an industrial atmosphere (Kearny, N.J., USA) was modified to allow calculation of an atmospheric corrosion resistance index based on chemical composition. The modification consisted of deletion of the constant and changing the signs of all the terms in the formula. The modified formula for calculation of the atmospheric corrosion resistance index (I) is given below. The higher the index, the more corrosion resistant is the steel.

$$I = 26.01 (\% \text{ Cu}) + 3.88 (\% \text{ Ni}) + 1.20 (\% \text{ Cr}) + 1.49 (\% \text{ Si}) + 17.28 (\% \text{ P}) - 7.29 (\% \text{ Cu}) (\% \text{ Ni}) - 9.10 (\% \text{ Ni}) (\% \text{ P}) - 33.39 (\% \text{ Cu})^2$$

B-3.3 The predictive formula should be used only for steel compositions within the range of the original test materials in the Larrabee-Coburn data set. These limits are as follows:

- $0.012 \leq \text{Cu} \leq 0.51$
- $0.05 \leq \text{Ni} \leq 1.1$
- $0.10 \leq \text{Cr} \leq 1.3$
- $0.10 \leq \text{Si} \leq 0.64$
- $0.01 \leq P \leq 0.12$

B-3.4 The minimum acceptable atmospheric corrosion index should be a matter of negotiation between the manufacturer/supplier and the purchaser.

ANNEX C
(Informative)
**ADDITIONAL INFORMATION FOR THE USE OF STEEL WITH
IMPROVED ATMOSPHERIC CORROSION RESISTANCE**

The corrosion-inhibiting effect of the auto-protective oxide layer relates to the nature of its constituents and to the particular distribution and concentration of alloying elements in it. The resistance to atmospheric corrosion depends on weather conditions giving a succession of dry and wet periods for the forming of the auto-protective oxide layer of the base metal. The protection afforded depends on the environmental and other conditions prevailing at the site of the structure.

Provisions should be made in the design and fabrication of the structure, for the auto-protective oxide layer on the surface to form and regenerate itself unimpeded. It is the responsibility of the designer to include corrosion of unprotected steels in his or her calculation and, as far as is necessary, to compensate for this by increasing the thickness of the product.

Conventional surface protection is recommended when the content of particular chemical substances in the air is significant. It is absolutely necessary where the structure is in contact with water for long periods, is permanently exposed to moisture, or is to be used in a marine atmosphere. Before painting, the products should be descaled. Under comparable conditions, the susceptibility to corrosion of steel with improved atmospheric corrosion resistance under painting is less than that for conventional structural steels.

The surface of structures which are not exposed to the elements, but may be subject to the build-up of condensation, should be appropriately ventilated. Otherwise, a suitable surface protection is necessary. Generally valid statements on the corrosion process cannot be made, due to the extent to which the process depends on the prevailing climatic conditions and the details of the structure.