

*Draft Indian Standard***STEEL STRAPPING FOR PACKAGING***(Third Revision)***1 SCOPE**

This standard covers the requirements for **four** grades of steel strapping for packaging.

2 REFERENCES

The following standards contain provisions, which through reference in this text, constitute provisions of this standard. At the time of publication, the editions indicated were valid. All standards are subject to revision and parties to agreements based on this standard are encouraged to investigate the possibility of applying the most recent editions of the standards indicated below:

<i>IS No.</i>	<i>Title</i>
IS 228 (In various parts)	Methods for chemical analysis of steels
IS 1403 (Part 1) : 1993	Metallic materials — Sheet and strip 3 mm thick or less — Reverse bend test
IS 1608 (Part 1) : 2022	Metallic materials — Tensile testing: Part 1 Method of test at room temperature
IS 8910 : 2022	General technical delivery requirements for steel and steel products
IS 9844 : 1981	Methods of testing corrosion resistance of electroplated and anodized aluminium coatings by neutral salt spray test

3 SUPPLY OF MATERIAL

General requirements relating to the supply of cold rolled steel strips shall conform to IS 8910 : 2022

4 MANUFACTURE

Unless otherwise agreed, the strips shall be manufactured from steel made by any process.

5 CHEMICAL COMPOSITION**5.1 Ladle Analysis**

The ladle analysis of steel, when carried out either by the methods specified in relevant part of IS 228 or any other established instrumental/ chemical method, shall be as given in Table 1

In case of dispute, the procedure given in relevant parts of IS 228 shall be referee method.

5.2 Product Analysis

Permissible variation in the case of product analysis from the limits specified in 5.1 shall be as given in Table 2.

Table 1 Chemical Composition
(Clause 5.1)

Grade	Constituent, Percentage			
	Carbon	Manganese	Sulphur, Max	Phosphorous, Max
1	0.25 to 0.45	1.10 to 1.60	0.035	0.035
2 and 3	0.20, Max	0.90, Max	0.050	0.050
4	0.50 to 0.60	0.60 to 0.90	0.035	0.035

NOTE — The steel may be made with micro-alloying elements like niobium, vanadium, titanium and boron either individually or in combination, on agreement, in which case total micro-alloying elements should not exceed 0.2 percent in ladle analysis. However, in case of Boron, the limit shall be 0.1 percent

Table 2 Product Analysis
(Clause 5.2)

Constituent	Variation Over the Specified Limits, Percent, Max
Carbon	± 0.02
Manganese	± 0.03
Sulphur	+ 0.005
Phosphorous	+ 0.005

NOTE — Variation shall not be applicable to both over and under the specified limits in several determinations in a heat.

6 TENSILE TEST

6.1 Number of Tensile Tests

One tensile test shall be taken from each lot of 25 tonnes of material or part thereof from each cast.

6.1.1 Where strips of more than one thickness are rolled from the same cast, one tensile test shall be made for each thickness of strip

6.1.2 The test sample may be taken from either end of the strips and shall be at least 1.5 m in length

6.2 Tensile Test Piece

6.2.1 Tensile test may be carried out on full width of the strip in accordance with IS 1608 (Part 1).

6.2.2. When tested, the tensile strength and percentage elongation shall conform to the requirements given in Table 3.

Table 3 Tensile Properties
(Clause 6.2.2)

Grade	Tensile Strength, MPa	% Elongation, Min Gauge Length 50 mm
1	900, Min	5
2	590 to 900	7
3	290 Min	12
4	1 170 Min	8

7. BEND TESTS

One bend test shall be taken from each lot of 10 tonnes of material of part thereof of each cast .

7.1 Bend test

- 7.1.1** A test specimen from a sample length of steel strapping is fastened in the test jaws with a radius of 3 mm on their inner edges (*see* [Fig. 1](#)).
- 7.1.2** The free end of the steel strapping sample is bent 90°, in the opposite direction, over the rounded edge of the supports (*see* [Fig. 1](#)).
- 7.1.3** One bend shall consist of a 90° bend in one direction and return to the original position.
- 7.1.4** Make successive bends in opposite directions.
- 7.1.5** Disregard cracking or flaking of the coating during testing.
- 7.1.6** One bend test shall be taken from each lot of 10 tonnes of material or part thereof from each cast.
- 7.1.7** Steel strapping of various thickness shall withstand the minimum number of bends, as shown in [Table 4](#)
- 7.1.8** The number of bends when failure by cracking occurs is recorded. The minimum number of bends to failure is shown in [Table 4](#)

Table 4 — Minimum bends to failure
(Clauses 7.1.7, 7.1.8)

Nominal thickness mm	Number of bends
	<i>R</i> = 3 mm
0.4	12
0.5	8
0.6	6
0.7	5
0.8	5
0.9	5
1.0	4
1.2	3
1.27	3
1.45	3

NOTE *R* is the bend radius.

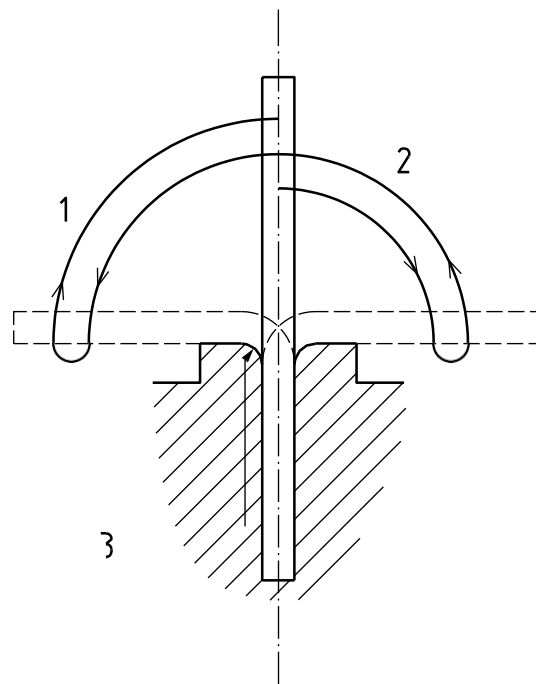

Key

- 1 2 bends
- 2 1 bend
- 3 bend radius

Fig 1 — Bend test and method of counting bends

8 RETEST

Should any of the test pieces first selected fail to pass any of the tests specified in this standard, two further samples shall be selected from the same lot for testing in respect of each failure. Should the test pieces from both these additional samples pass, the material represented by the test samples shall be deemed to comply with the requirements of that particular test. Should the test pieces from either of these additional samples fail, the material represented by the test samples shall be deemed as not complying with this standard.

9 FREEDOM FROM DEFECTS

9.1 The strips shall be free from harmful defects such as scales, rust, blisters, laminations, pittings, porosity and other harmful defects such as sharp, cracked or torn edges, or any other defects which may impair the serviceability of the strips. Edges shall be properly finished to eliminate burrs and sharp edges.

9.2 The degree or amount of surface defects in a coil may be expected to be more than in cut lengths because of the impossibility of rejecting portions of coil. This shall be considered by the purchaser in his assessment of the material. An excessive number of defects may be the cause for rejection.

10 DIMENSIONS, SHAPE AND TOLERANCES

10.1 Nominal dimensions

The nominal thickness and width of steel strapping should be as shown in [Table 5](#). When agreed between the manufacturer and the purchaser, other dimensions may be supplied.

Table 5 — Width and thickness
(Clause 10.1)
(Dimensions in millimetres)

Nominal thickness	Nominal width						
	12.7	16	19	25.4	31.75	40	50
0.4	√	√					
0.5	√	√	√				
0.6	√	√	√				
0.7			√				
0.8			√	√	√		
0.9			√	√	√	√	
1.0				√	√	√	
1.2					√		√
1.27					√		√
1.45					√		

10.2 Dimension tolerances -The dimension tolerances of steel strapping shall be in accordance with [Table 6](#).

Table 6 Dimension tolerances
(Clause 10.2)
(Tolerances in millimetres)

Dimension	Tolerances
Thickness	± 0.05
Width	± 0.13

10.3 Shape tolerances

The shape tolerances of steel strapping when tested as per method specified in Annex A, shall be in accordance with [Table 7](#).

Table 7 Shape Tolerances
(Clause 10.3)

Shape	Specimen length 2 000 mm (per 2 000 mm length) max.
Camber	10 mm
Flatness	24 mm
Twist	18°

10.4 Weld

Welding is not recommended due to safety reason unless there is an agreement between the manufacturer and the purchaser. Strength of manufacturer's process welded joints in coils of strapping shall not be less than 75 % based on the tensile strength shown in [Table 3](#).

10.5 Coil inside diameter

The recommended coil inside diameter is 406 mm and the tolerance shall be ± 2 mm. When agreed between the manufacturer and the purchaser, other inside diameter may be supplied.

11 SURFACE FINISH

11.1 Unless otherwise agreed, steel strips may be supplied in any one of the following surface finishes. Bright and bluish grey strips shall be adequately coated with rust preventive.

- a) Bright — The natural surface finish of uncoated steel in a cold rolled condition.
- b) Blue/Bluish Grey — The blue/ bluish grey finish is imparted by heat which also cleans the surface.
- c) Painted — Various paints are used to provide a degree of resistance to corrosion or to check chemical reaction between the strapping and the surface of the goods being strapped.
- d) Electro zinc Galvanized — A zinc coating is applied by an electrolytic deposition process to provide a degree of resistance to corrosion.
- e) Hot Dipped Galvanized — A corrosion resistance coating is applied by immersion in a bath of molten zinc.

12 CORROSION RESISTANCE

12.1 The finished strip shall be subjected to salt spray test in accordance with IS 9844 : 1981 for the time given below:

- a) Painted (one coat) - 72 hours for air drying quality and 96 hours for stoving quality,
- b) Electro zinc galvanized, and hot dip galvanized - 144 hours.

13 PACKING

Strips shall be supplied in coils securely in Ribbon or Oscillated wound type (*see* Annex B)

14 MARKING

14.1 Each coil shall be marked with the following:

- a) Grade of the material
- b) Size, and
- c) Manufacturers name.

14.2 BIS Certification Marking

The product(s) conforming to the requirements of this standard may be certified as per the conformity assessment schemes under the provisions of the *Bureau of Indian Standards Act, 2016* and the Rules and Regulations framed thereunder, and the products may be marked with the Standard Mark.

Annex A

(Clause 10.3)

Measurements of shape

A.1 Measurement of camber

Camber is measured on the greatest deviation of the concave edge from a straight edge in any 2 000 mm length steel strapping, as shown in [Fig. A.1](#).

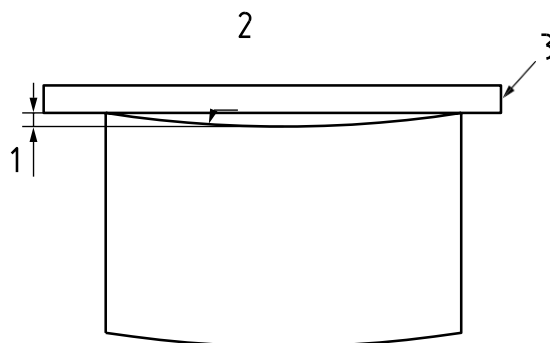

Key

- 1 edge camber
- 2 side edge (concave side)
- 3 straight edge

Fig. A.1 — Measurement of camber

A.2 Measurement of flatness

The steel strapping of any 2 000 mm length is lied under its own weight on the platform. Flatness is measured as the maximum distance from the lower surface of steel strapping to the platform, as shown in [Fig. A.2](#).

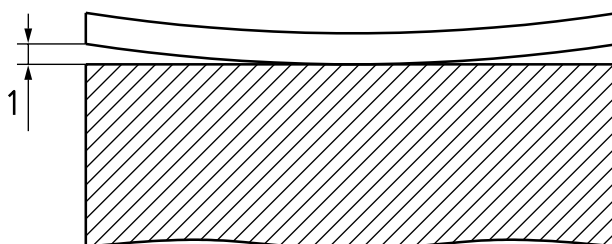

Key

- 1 maximum deviation from flatness

Fig. A.2 — Measurement of flatness

A.3 Measurement of twist

The steel strapping of any 2 000 mm length is lied under its own weight on the platform. Twist is measured as the maximum dip angle formed by the lower surface of steel strapping to the platform, as shown in [Fig. C.3](#).

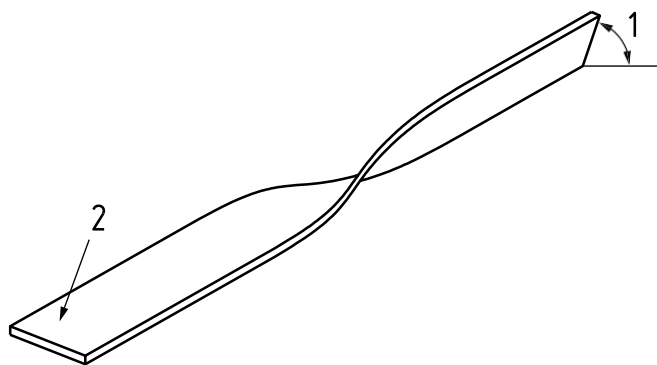

Key

- 1 twist
- 2 straight edge

Fig. A.3 — Measurement of twist

ANNEX B

(Clause 13)

PACKAGING

B.1 Packaging of strapping coil (unit packed)

B.1.1 Coil straps

Unit packed coil is recommended to be packed with equally spaced steel tie straps not less than 16 mm by 0,5 mm. The three strap ties in ribbon wound coil shall be spaced 120° apart (see [Fig. B.1](#)) while the four strap ties in oscillated wound coil shall be spaced 90° apart (see [Fig. B.2](#)).

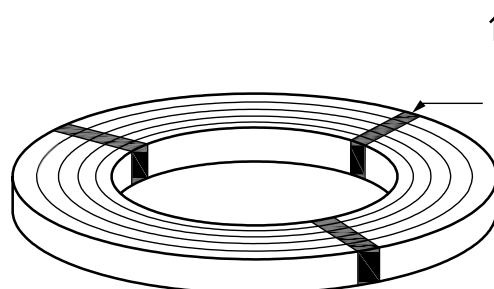

Key

1 strap tie

Fig. B.1 Example of ribbon wound strapping coil

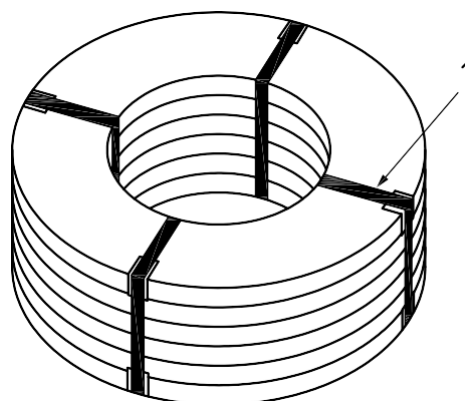

Key

1 strap tie

Fig. B.2 Example of oscillated wound strapping coil

B.1.2 Coil wrapping

Each coil is recommended to be wrapped with wrapping paper. Manufacturer can use different packaging way and materials to protect the coils during transportation. The wrapping process shall be continuous and complete. Each wrap shall overlap each preceding layer of wrap at least 50 %. Coil wrapping shall be accomplished in a neat and compact unit pack manner. An example of coil wrapping packaging is shown in [Fig. B.3](#).

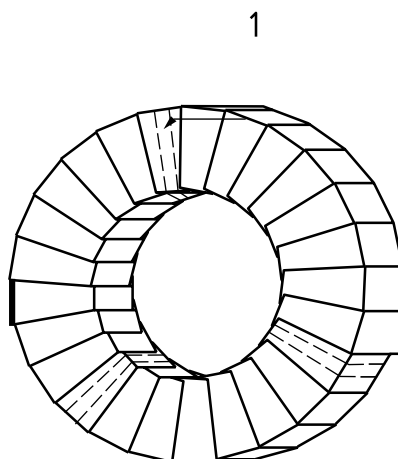

Key

1 strap tie

Fig. B.3 Example of strapping coil wrapping

B.2 Coils pile packed

B.2.1 Bare packaging

Steel strapping's coil is recommended to be stacked in a pile and bundled by-4 strap ties without any other packaging materials. An example of bare packaging is shown in [Fig. B.4](#).

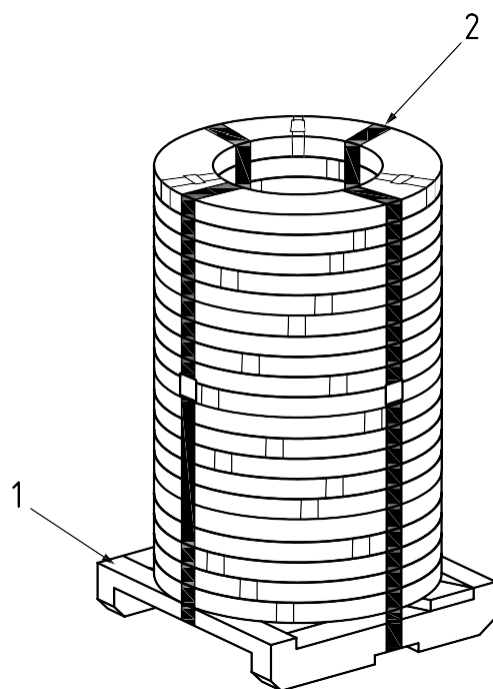

Key

- 1 pallet
- 2 strap tie

Fig. B.4 Example of bare packing

B.2.2 Regular packaging

Packaging materials are recommended to include pallet, volatile corrosion inhibitor) (VCI) paper with plastic film or plastic woven cloth, six strap ties (two on the inside and four on the outside). An example of regular packaging is shown in [Fig. B.5](#).

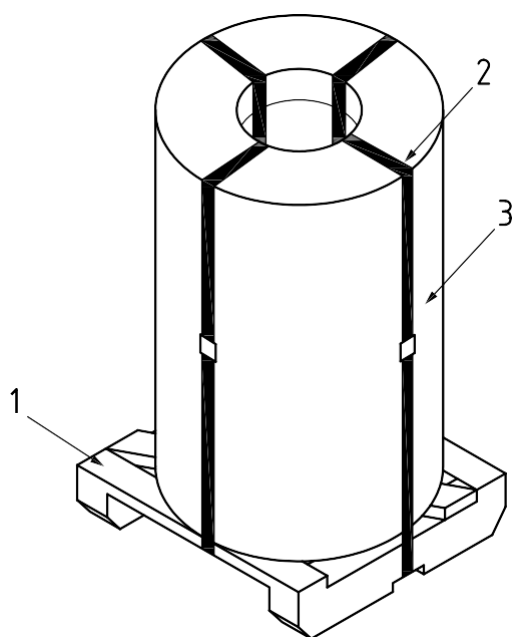
**Key**

- 1 pallet
- 2 strap tie
- 3 VCI paper

Fig. B.5 Example of regular packaging

B.2.3 Waterproof packaging

Packaging materials are recommended to include pallet, outside VCI paper with plastic film or plastic woven cloth, anti-rust plastic film, steel circle protector for packaging edge, desiccants, six strap ties (two on the inside and four on the outside). An example of waterproof packaging is shown in [Fig. B.6](#).

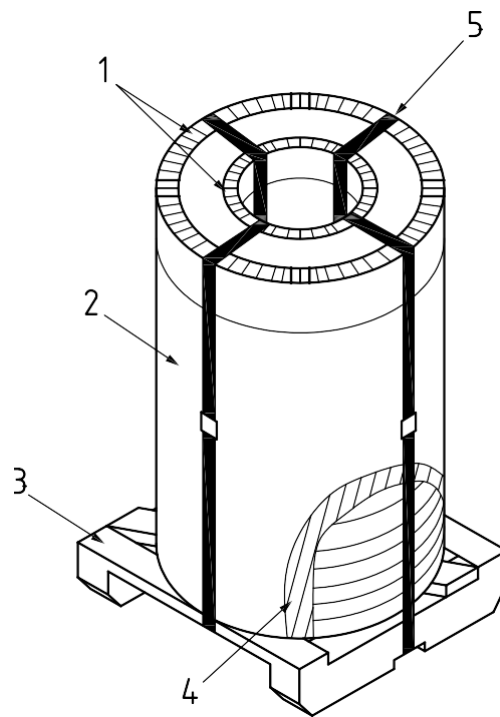

Key

- 1 steel circle protector
- 2 VCI paper
- 3 pallet
- 4 anti-rust plastic film
- 5 strap tie

Fig. B.6 Example of waterproof packaging