

Draft Indian Standard**METHOD OF DYNAMIC FORCE CALIBRATION OF AXIAL LOAD FATIGUE TESTING MACHINES BY MEANS OF A STRAIN GAUGE TECHNIQUE***(First Revision of IS 6886)***FOREWORD**

This standard was first published in 1973. This revision has been brought out to bring the standard in the latest style and format of the Indian Standards.

This standard was prepared in order to unify method of dynamic force calibration of axial load fatigue testing machines by means of a strain gauge technique.

Whilst it is relatively simple to carry out a calibration of the forces applied by a fatigue testing machine under static conditions, it is essential to establish that the dynamic forces actually applied to the test piece are those indicated by the machine within acceptable limits of accuracy.

As some fatigue machines operate over a range of testing frequencies, the inertia effects of moving parts are not constant but vary. For such machines, a dynamic correction factor may therefore have to be applied to the indicated forces to obtain the force actually effective at the test piece. This factor is a function, for example, of the vibrating mass of the machine, of the test piece stiffness and the operating frequency, and the correction data is customarily supplied by the manufacturer of the testing machine. Thus, the object of fatigue testing machine calibration is to compare indicated forces, multiplied by an appropriate correction factor where applicable, with actual test forces over the operating range of the machine.

This standard is particularly concerned with the calibration of axial load machines as the procedures for their calibration are generally more complex. The calibration of rotating bending and torsional fatigue testing machines can usually be satisfied simply by direct measurements of the effective test piece length and by direct verification of the applied force or displacement.

In reporting the result of a test or analysis made in accordance with this standard, is to be rounded off, it shall be done in accordance with IS 2:2022 'Rules for rounding off numerical values (revised)'.

1 SCOPE

1.1 This standard provides guidance for the dynamic force calibration of fatigue testing machines including special attachments, such as, grips, which may affect the calibration of the machine. It deals exclusively with axial load machines in which test pieces, usually symmetrical about a longitudinal axis, are subjected to fluctuating and reversed forces along that axis (see *also* IS 5074).

1.2 Whilst it is recognised that unsymmetrical specimens (components and structures), are sometimes tested, it is common practice to determine stresses within them from measurements by strain gauges applied to the test specimens as required, and in such cases dynamic force calibration of the machine may not be necessary.

1.3 The standard applies both to the calibration of new testing machines by the manufacturer and to the verification of machines in service. In the latter case, it may not be necessary required for the overall calibration of a machine. Apply all the procedures required for the overall calibration of a machine.

1.4 The calibration of special purpose machines and test rigs are not specifically covered in this standard but procedures similar to those described may be applied to suit particular applications.

2 REFERENCES

The standards listed below contain provisions which, through references in this text, constitute provisions of this standard. At the time of publication, the editions indicated were valid. All standards are subject to revision, and parties to agreements based on this standard are encouraged to investigate the possibility of applying the most recent editions of the standards indicated below:

<i>IS No.</i>	<i>Title</i>
IS 5074	Method of axial load fatigue testing of steel
IS 1828 (Part 1) :2022/ ISO 7500- 1 : 2018	Metallic materials - Calibration and verification of static uniaxial testing machines - part 1: Tension/compression testing machines - Calibration and verification of the force-measuring system

3 PRINCIPLE OF TEST

3.1 Calibration bars, appropriate to the dimensions of the testing machine and the force ranges to be checked, are instrumented by the application of electrical resistance strain (ERS) gauges. Each calibration bar is subjected to incremental loading in a static testing machine of known accuracy, and the electrical strain outputs from the gauges are recorded. The calibration bar, as calibrated statically, is then used for direct measurement of the forces applied by the fatigue testing machine and compared with the indicated forces. The procedure assumes identical performances of the calibration equipment under static and dynamic conditions, this assumption is essentially valid over the range of frequencies covered by fatigue machines in general use.

3.2 Successful application of the procedure is dependent on a satisfactory design of calibration bar, on the correct use of suitable strain gauges and on the choice of compatible dynamic strain recording instruments.

4 REFERENCE SYMBOLS

4.1 The following reference symbols have been used in this standard:

<i>Symbo</i>	<i>Description</i>
<i>l</i>	

D	Diameter of the gripped end (<i>see</i> Fig. 1)
d	Diameter where the stress is maximum (<i>see</i> Fig. 1)
L_c	Parallel length (<i>see</i> Fig. 1 and 2)
l	Effective gauge length of the ERS gauges used
r	Transition radius from the parallel length to gripped ends (<i>see</i> Fig. 1 and 2)
a	Thickness of test section of rectangular cross-section (<i>see</i> Fig. 1 and 2)
b	Width of rectangular cross section where the stress is maximum (<i>see</i> Fig. 1 and 2)
B	Width of rectangular cross section at gripped end (<i>see</i> Fig. 2)
F_{max}	Maximum force of the machine
F_m	Mean force
$F_{m max}$	Maximum mean force of the machine
F_R	Dynamic force range
$F_{R max}$	Maximum dynamic force range of the machine
$F_{a max}$	Maximum force amplitude of the machine

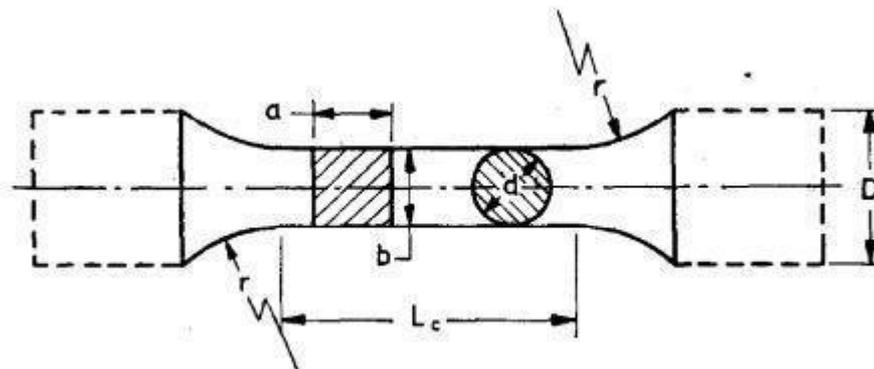

FIG. 1 CALIBRATION BAR OF CIRCULAR CROSS SECTION OR SQUARE CROSS SECTION WITH CIRCULAR ENDS

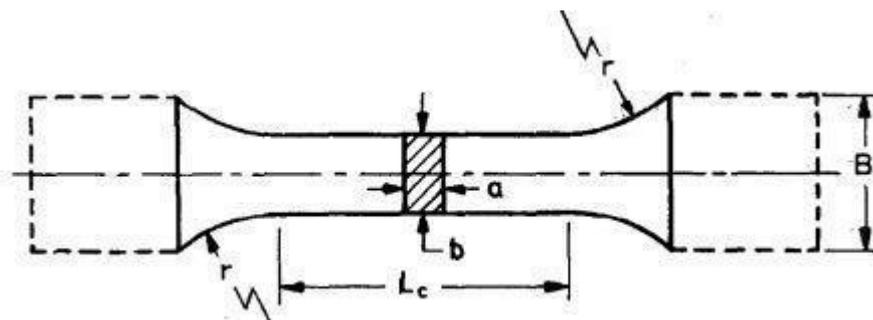

FIG. 2 CALIBRATION BAR OF RECTANGULAR CROSS SECTION

5. CALIBRATION BARS

5.1 General

5.1.1 Calibration bars of any suitable design and material may be used but it is recommended that, where possible, they be of similar form to the test piece normally being tested in the particular fatigue machine. They may be of circular, square or rectangular cross section, and in the case of circular and square bars, a hollow section is permissible to facilitate the measurement of small forces. ERS load cells which fulfil the requirements mentioned above may also be used.

5.1.2 As a guide to the selection of material and the design of the bar, the maximum stated capacity shall be such that 150 percent of that capacity does not exceed the 0.01 percent proof stress (non-proportional elongation method) of the material.

5.1.3 It is recommended that, at the rated maximum force range at which the bar is to be used, the strain imposed should be approximately 1200 microstrains either in tension or compression.

5.2 Proportions - The proportions of calibration bars, which have been found satisfactory for use in direct stress fatigue testing machines, are as follows:

5.2.1 Bars of the Circular Section (see NOTE 1)

L_c shall be at least $d + l$ (see also Note 2)

r and D shall be equal to greater than $2d$

5.2.2 Bars of Square and Rectangular Cross Section

L_e shall be at least $b + l$ (see also Note 2)

r and B shall be equal to or greater than $2b$.

NOTE 1 - Bars of square cross section may have circular ends.

NOTE 2 - L_o should not be such that buckling will occur if the strain cycle goes into compression.

5.3 Machining

5.3.1 Bars shall be machined in accordance with **IS 5074**.

5.3.2 The corners of square and rectangular calibration bars shall be dressed to a radius of at least 1.5 mm. The surface of the bar shall not have any stamp marks on critical areas.

6. STRAIN GAUGES

6.1 A sufficient number of active strain gauges shall be attached to the calibration bar at mid-length to ensure that an average of the strain can be adequately ascertained. In no circumstances shall there be less than four strain gauges attached to the bar. For bars of circular cross section, the active gauges shall be placed at points equally distributed around the periphery of the bar. For bars of square cross section, the gauges shall be disposed symmetrically on each face. For bars of rectangular cross section, one gauge shall be positioned in the centre of each edge of the bar and the remaining gauges shall be disposed symmetrically on the two faces. Where it

is not possible to position gauges on the edges of the bar, such as in the case of sheet material, they shall be placed symmetrically about the axis of the bar on each face.

6.2 Suitable techniques shall be used to compensate for variations in out-put signal due to temperature changes. It is recommended that gauges be fixed to the bar in a direction transverse to the applied force within the test section for the purpose of temperature compensation. With certain types of recording instruments, it may only be possible to use longitudinally mounted gauges, in which case these should be self-compensating for temperature.

6.3 Gauges should be affixed to the bar in accordance with the manufacturer's instructions for their optimum performance. The surfaces of the calibration bar should be such as to ensure an adequate bond between the strain gauge and the bar. Care should be taken when affixing the strain gauges to ensure that the surfaces of the bar and gauges are free from contamination by oil, grease, etc.

6.4 All gauges should be protected from mechanical and environmental damage by the application of suitable materials.

7. RECORDING INSTRUMENTATION

7.1 The calibration bar, gauges and associated equipment shall be capable of resolving force changes of one-fifth of the maximum machine errors allowed in the calibration (*see 9.1*). The design should be such that the response to fluctuating and reversed forces at the frequencies and waveforms to be used can be predicted, from the response to steady forces, with an uncertainty of not more than one-fifth of the maximum machine errors allowed in the calibration (*see 9*).

8. CALIBRATING THE CALIBRATION BAR

8.1 Preliminary Check - Prior to static calibration, the calibration bar may be mounted in a fatigue testing machine and subjected to a sufficient number of cycles to ensure that the strain gauges are functioning satisfactorily under dynamic conditions.

8.2 Testing Machine for calibrating the Bar-The bar shall be calibrated in a static testing machine complying with grade 1.0 requirements of **IS 1828 (Part 1)**. The machine shall not be used below one-fifth of its scale in any of its force ranges.

8.3 Mounting of the Calibration Bar in the Static testing Machine - The calibration bar shall be mounted in the machine so that the force centre line of the machine lies, through the centre line of the bar and in such a manner that it cannot move its. Position during the application of the series of calibration forces. In certain types of -machine, the loading head is movable and also has to, be centralized.

8.4 Calibrating Procedure -The sequence for the procedure is as follows.

8.4.1 Connect the recording instruments to the calibration bar strain gauges and, after switching on, allow the requisite period for stabilization of all instrumentation. Before commencing calibration, apply and remove several times a force of 1.1 times the maximum force which is to be applied during calibration.

8.4.2 With zero force applied to the bar, set the strain recording instrument to indicate zero strain. Apply the maximum calibration force and observe the strain produced; then restore the applied force to zero and after a period of not less than one minute observe any indicated strain. The difference between the two strain readings made at zero force should not exceed 1 percent of the strain observed at maximum force.

8.4.3 Reset the strain recording instrument to indicate zero strain at zero force. Apply static forces in not less than 5 approximately equal increments up to the maximum of the range and down to zero again in the same steps. At each increment and decrement, with the force maintained precisely and steadily, record the electrical strain output from the calibration bar.

8.4.4 Off-load the machine and record zero-load electrical output from the calibration bar.

8.4.5 Repeat operations given in **8.4.3** and **8.4.4** twice to obtain three series of incremental and decremental calibration readings. Between the second and third series of readings, the recording instruments shall be disconnected and the calibration bar removed from the testing machine, and then re-mounted in accordance with **8.3**.

8.4.6 The static calibration of the bar is obtained from the average of the difference of the electrical strain outputs from zero-force for the corresponding increment and decrement of once in each of the three 'series of readings. At each calibration force, the incremental and decremental readings shall be averaged and adjustment for the averaged zero force reading shall be applied. The relationship between force and strain shall essentially be linear.

8.4.7 For each series, at each calibration force the difference between the strain readings in the two directions shall be not greater than 1 percent of the strain at maximum force.

8.4.8 At each calibration force, the difference between the highest and the lowest of the three average strain outputs shall not exceed 1 percent of the average strain at maximum force.

8.5 Recalibration of Bar - If it is subsequently necessary to verify the calibration of the bar, the procedure described in **8.4** may be reduced to a single series of readings, provided the relationship between force and strain does not differ from the original calibration at each of the calibration forces by more than **0.5** percent of the original calibration strain at maximum force. Otherwise, the full procedure described in **8.4** shall be carried out.

9. PROCEDURE FOR CALIBRATING FATIGUE MACHINES

9.1 General - For the calibration of a fatigue machine over its entire range of force and operating frequency, it is usually necessary to use several calibration bars. The overall calibration consists of procedures covering both static and dynamic operating conditions. Prior to the calibration, it shall be ascertained that the machine is in good working order and it should be operated in accordance with the manufacturer's instructions.

9.2 Dynamic Calibration of Mean Forces and Force Ranges

9.2.1 For the calibration of dynamic forces, the following procedure shall be adopted. At a number of mean forces, distributed approximately equally throughout the range of mean forces available in the normal operation of the testing machine, different dynamic force ranges. Several calibrations are performed using. Depending on the type of axial load fatigue testing machine, the mean forces and dynamic force ranges given in Table 1 shall be used for

calibration purposes. The test series given in the table should be regarded as the minimum for such purposes. The calibration shall be repeated twice at each mean force to give three series in all. It may be necessary to repeat this procedure at different frequencies and different test piece compliances.

9.2.2 The typical sequence for the dynamic calibration procedure is as follows:

- a) Fit the appropriate calibration bar into the machine observing the requirements of **8.3**.
- b) Connect the recording instruments' to the calibration bar strain gauges and, after switching on, allow sufficient time for stabilization of all instrumentation.
- c) Adjust the force and speed ranges of the machine as appropriate.
- d) Apply the mean force and the various dynamic force ranges, and at each dynamic condition check the operating frequency and record the maximum and minimum values of the fluctuating electrical strain output from the calibration bar.
- e) Repeat operation (**d**) for each mean force level as described above.
- f) Off -load the machine and check zero - load electrical outputs of the calibration bar.
- g) Repeat operations (**c**) to (**f**) for any additional selected operating frequencies.
- h) Where necessary for determining a dynamic correction factor, the testing machine/ calibration bar stiffness should be obtained during the calibration by measuring the ratio of unit length increase measured between the jaws of the machine to the unit force increase.

10. ASSESSMENT OF MACHINE PERFORMANCE

10.1 Repeatability – For a given indicated force, maximum or minimum, the difference between the highest and the lowest of the three strain outputs shall not exceed 1 percent of the average strain at maximum force.

10.2 Accuracy - The results obtained from the procedure described in **9.2** are compared with the force readings indicated by the machine. The errors in the maximum and minimum forces under consideration shall not exceed 2 percent of the maximum tensile or compressive force of the machine scale in use.

NOTE — This requirement for accuracy is not absolute as the error in the calibration equipment is not taken into account.

11. INITIAL CALIBRATION OF MACHINE

11.1 Provided the requirements for accuracy given in **10** are met, the readings indicated by the machine may be used for subsequent tests. If the requirements of **10** are not met, calibration curves should be prepared (*see* **12**) and these curves should be used in subsequent tests.

12. CALIBRATION CURVES

12.1 Preparation -The results obtained from the full procedure described in **9** are used for establishing basic calibration curves for the testing machine. A curve is plotted of the force

indicated by the calibration bar against the force indicated by the machine covering each operating frequency selected.

TABLE 1 MINIMUM TEST SERIES FOR CALIBRATION PURPOSES
(Clause 9.2.1)

A) Tension – (or compression)- Fatigue Testing machine with $F_{a\ max} < F_{max}$
(for example, $F_{a\ max} = 0.5 F_{max}$)

$\frac{F_m}{F_{max}}$	0.2	0.4	0.5	0.6	0.8	
$\frac{F_R}{F_{max}}$	}	0.1	0.1		0.1	
		0.2	0.2	0.2	0.2	0.1
		0.3	0.3		0.3	0.2
		(0.4)	0.4	0.4	0.4	0.3
			0.5		0.5	0.4
			0.6	0.6	0.6	
			0.7		0.7	
			(0.8)	0.8	0.8	
				(1.0)		

B) Tension - Compression -Fatigue Testing Machines with $F_{a\ max} < F_{max}$ (for example, $F_{a\ max} = 0.5 F_{max}$)

$\frac{F_m}{F_{a\ max}}$	- 1.0	- 0.5	0	+ 0.5	+ 1.0	
$\frac{F_R}{F_{R\ max}}$	}	0.2	0.2	0.2	0.2	0.2
		0.4	0.4	0.4	0.4	0.4
		0.6	0.6	0.6	0.6	0.6
		0.8	0.8	0.8	0.8	0.8
		1.0	1.0	1.0	1.0	1.0

C) Tension - Compression - Fatigue Testing Machines with $F_{a\ max} = F_{max}$

$\frac{F_m}{F_{max}}$	-0.6	-0.4	-0.2	0	+0.2	+0.4	+0.6
-----------------------	------	------	------	---	------	------	------

$\frac{F_R}{F_{max}}$	0.4	0.4	0.4	0.4	0.4	0.4	0.4
	0.8	0.8	0.8	0.8	0.8	0.8	0.8
		0.12	1.2	1.2	1.2	1.2	
			1.6	1.6	1.6		
				2.0			

NOTE — The values given in parentheses cannot be obtained in the majority of machines. In such cases, the last dynamic force range should equal the full range available at that mean force.

12.2 Presentation of Results – Details of the calibration bar and its method of attachment in the machine should be stated on the calibration curves supplied with the machine. By interpolation, further curves may be derived to cover forces and operating frequencies other than those selected for calibration purposes.

NOTE — The calibration curves described above do not take account of differing mass/frequency relationships of the test piece and attachments. Where required, appropriate dynamic force correction factors [see 9.2.2 (h)] should be provided here in the form of a graph or by a formula.

13. RECALIBRATION OF MACHINE

13.1 For machines in service, it may be necessary to carry out a further calibration in which case the procedures described in 8 and 9 shall be followed. Ability and the machine shall comply with the requirements for repeat-accuracy given in 10. If the results obtained are not within these accuracy requirements, further calibration curves as described in 12 should be prepared.

14. VERIFICATION OF MACHINE

14.1 Procedure - It may only be necessary to verify the machine calibration at selected force levels and frequencies covering the range of operating conditions at which the machine is usually employed.

14.2 Accuracy of Verification - At the conditions selected for verification purposes and applying the calibration curves described in 12, as appropriate, the errors found shall not exceed the requirements stated in 10. If errors greater than those stated 10 are apparent, the testing machine shall be completely recalibrated as described in 13 and new calibration curves prepared.

NOTE — Errors greater than those stated in 10 may be due to wear in moving parts, misalignment of optical parts, slip of indicator needles, overstraining of springs, etc. It is accordingly recommended that the advice of the testing machine manufacturer be sought if significant errors are found during recalibration or verification.

14.3 Intervals Between Verification - The time between verifications will depend on the type of testing machine, the standard of maintenance and the amount of usage. Under normal circumstances, it is recommended that verification be carried out at intervals not exceeding 12 months. A machine shall in any case be verified if it is moved to a new location necessitating dismantling or is subject to major repairs or adjustments.