

For BIS Use Only

Preliminary Draft

BUREAU OF INDIAN STANDARDS

DRAFT FOR COMMENTS ONLY

(Not to be reproduced without the permission of BIS or used as an Indian Standard)

भारतीय मानक मसौदा

**हल्के गेज के धातु के कंटेनर — पुनः न भरे जाने वाले
एलपीजी कार्ट्रिज — सामान्य अपेक्षाएँ**

Draft Indian Standard

**LIGHT GAUGE METAL CONTAINERS — NON-REFILLABLE LPG
CARTRIDGES — GENERAL REQUIREMENTS**

ICS 55.120

Initial Draft Prepared by
Shri Manvinder Singh

Last date for receipt of comments
is 25 July 2024

FOREWORD

(Formal clause will be added later)

This standard is to keep pace with the latest technological developments and international practices. Also, the standard has been brought into the latest style and format of Indian Standards, and references of Indian Standards, wherever applicable have been updated. BIS certification marking clause has been modified to align with the *Bureau of Indian Standards Act, 2016*.

For the purpose of deciding whether a particular requirement of this standard is complied with the final value, observed or calculated, expressing the result of a test or analysis, shall be rounded off in accordance with IS 2 : 2022 ‘Rules for rounding off numerical values (*second revision*)’. The number of significant places retained in the rounded off value should be the same as that of the specified value in this standard.

Draft Indian Standard

**LIGHT GAUGE METAL CONTAINERS — NON-REFILLABLE LPG
CARTRIDGES — GENERAL REQUIREMENTS**

1 SCOPE

1.1 This document specifies minimum requirements for the construction, design, material, performance, test methods and marking at manufacture of non-refillable liquefied petroleum gas (LPG) cartridges.

1.2 This document is applicable to non-refillable LPG cartridges which:

- a) Predominantly comprise butane fuel gas (iso/normal);
- b) Have a total nominal capacity of up to 500 ml;
- c) Are intended to deliver gas in the vapour state when either positioned upright or in a horizontal orientation; and
- d) Are used with certain types of gas appliances, for examples, portable gas cookers.

2 REFERENCES

The standards given below contain provisions which, through reference in this text, constitute provision of this standard. At the time of publication, the editions indicated were valid. All standards are subject to revision, and parties to agreements based on this standard are encouraged to investigate the possibility of applying the most recent edition of these standards:

<i>Sl No./Other Publications</i>	<i>Title</i>
IS 1993 : 2018/ ISO 11949 : 2016	Cold-reduced tinmill products — Electrolytic tinplate (<i>fifth revision</i>)
IS 3400 (Part 20) : 2018/ ISO 1431-1 : 2012	Methods of test for vulcanized rubbers: Part 20 Resistance to ozone cracking — Static strain test (<i>second revision</i>)
IS 4576 : 2021	Liquefied Petroleum Gases — Specification (<i>fourth revision</i>)
IS 9844 : 1981	Methods of testing corrosion resistance of electroplated and anodized aluminium coatings by neutral salt spray test
IS/ISO 11951 : 2016	Cold-reduced tinmill products — Blackplate (<i>first revision</i>)
ISO 9227 : 2022	Corrosion tests in artificial atmospheres — Salt spray tests

3 TERMINOLOGY

For the purpose of this standard, the following definitions shall apply.

3.1 Non-refillable Liquefied Petroleum Gas Cartridge Non-refillable LPG Cartridge — Cartridge only filled up once with LPG.

3.2 Flange — Guide for setting the non-refillable liquefied petroleum gas cartridges (*see 3.1*) in the gas appliances in the appropriate direction.

3.3 Boss — Protruding part at the centre of the non-refillable liquefied petroleum gas cartridges (*see 3.1*) that houses the stem (*see also 3.5*) or another valve part.

3.4 Cartridge Cap — Cap for protecting the gas outlet of the non-refillable liquefied petroleum gas cartridges (*see 3.1*) for the gas appliances.

3.5 Stem — Part for vapour withdrawal which is fitted to a gas appliance.

4 GAS FILLED IN CARTRIDGE

4.1 Composition

The composition of LPG used in the cartridges shall be predominately Butane (C₄H₁₀) (greater than or equal to 95 percent mass fraction) confirming to IS 4576.

4.2 Nominal LPG Capacity

The nominal LPG capacity, when tested by the method described in **8.3.11**, shall not be greater than 225 g.

4.3 Odour

The butane used shall have an odour as specified in IS 4576.

5 CONSTRUCTION AND DESIGN

5.1 Construction

When the test described in **8.3** is carried out for testing the construction of each composition of the cartridges, each composition shall be proven to have been manufactured with safety and durability considerations and shall be free from any leakage of LPG, burst or deformation that can be detrimental to use when used under normal service and transportation conditions.

The pressing jointed part shall be effective in pressing, and the edges likely to be touched by hands during use shall be smooth.

Exposure to such vibrations and impacts as can occur during transportation or service shall not reduce the gas tightness and pressure resistance of the cartridges.

The cartridges shall be constructed in such a way that allows the LPG to be discharged in a gaseous state when it is under normal service conditions.

NOTE — Normal service conditions refers to conditions where the cartridge is installed in a gas appliance.

The cartridges shall be provided with a means to prevent LPG from being discharged when it is taken off from the gas appliances.

The cartridges shall be provided with a means to protect the protruding cartridge valve.

5.2 Design

5.2.1 Dimensions of Cartridge and Cartridge Valve

The dimensions of cartridge and cartridge valve, when tested by the method described in 8.3, shall conform to the requirements given in Table 2 corresponding to respective parts indicated in Fig. 1 and Fig. 2.

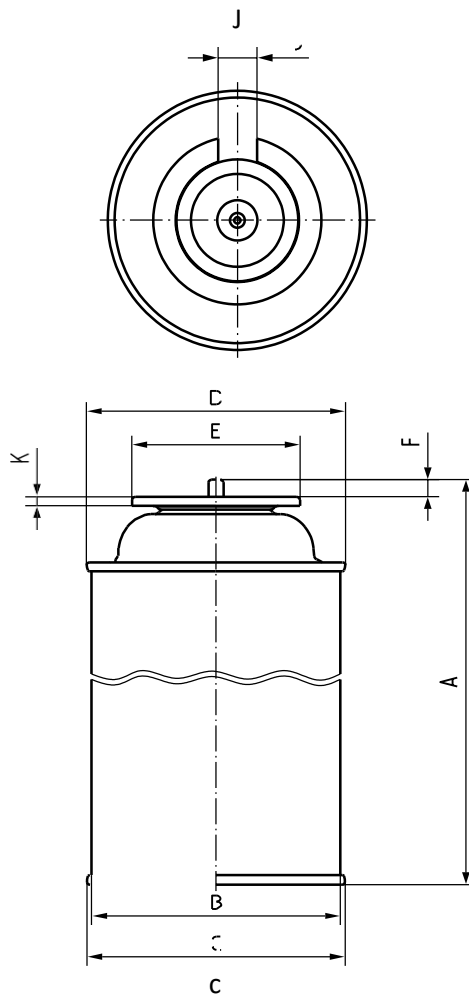

Key

- | | | | |
|---|-----------------------------------|---|-----------------------|
| A | Total height | E | Flange diameter |
| B | Outer diameter of cartridge-shell | F | Stem height |
| C | Lower cartridge diameter | J | Flange cut-away width |
| D | Upper cartridge diameter | K | Flange thickness |

FIG. 1 CARTRIDGE

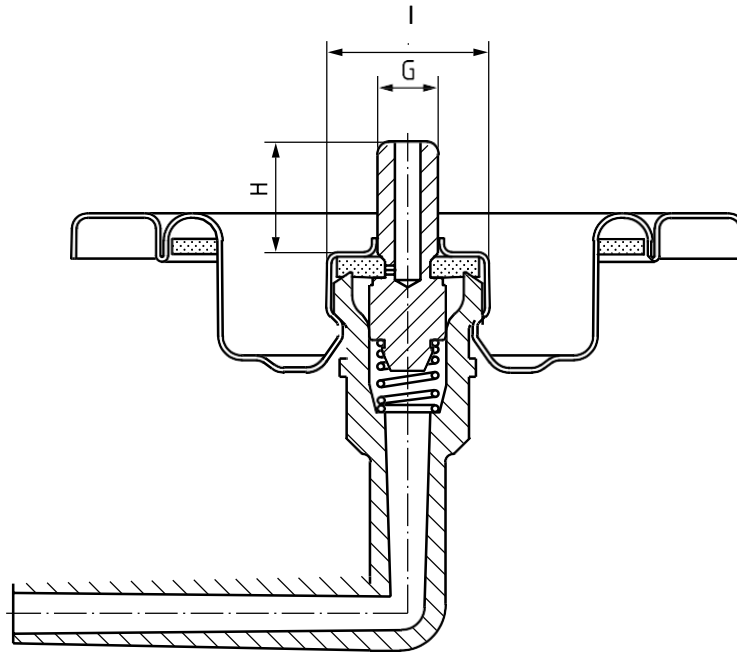

Key

- G Stem diameter
- H Stem length
- I Boss diameter

FIG. 2 CARTRIDGE VALVE

Table 2 Dimensions of Cartridge and Cartridge Valve

(Clause 5.2.1)

Sl No.	Key Item	Name	Dimensions (in mm)
(1)	(2)	(3)	(4)
i)	A	Total height	175.2 ± 0.6
ii)	B	Outer diameter of cartridge-shell	65.7 ± 0.5
iii)	C	Lower cartridge diameter	68.2 ± 0.4
iv)	D	Upper cartridge diameter	68.5 ± 0.4
v)	E	Flange diameter	44.5 ± 0.6
vi)	F	Stem height	5.6 ± 0.5
vii)	G	Stem diameter	4.0 + 0.05
viii)	H	Stem length	7.3 ± 0.5
ix)	I	Boss diameter ¹	10.65 ± 0.06
x)	J	Flange cut-away width	10.3 ± 0.3
xi)	K	Flange thickness	3.15 ± 0.25

¹ Boss diameter shall be an outside diameter measured at a position 1.5 mm below the upper end of the

5.2.2 Compressive (Stroke) Dimension and Initial Injection Stroke of Cartridge Valve

The compressive (stroke) dimension and the initial injection stroke of cartridge valve, when tested by the methods described in 8.3.12, shall conform to the requirements given in Table 3.

Table 3 Stroke Dimensions of Cartridge Valve
(Clause 5.2.2)

SI No.	Item	Dimension (in mm)
(1)	(2)	(3)
i)	Cartridge valve compressive (stroke) dimension	1.7 to 2.8
ii)	Initial injection stroke dimension	0.2 to 0.9

6 MATERIAL

6.1 Material of Cartridge Body

- The material used for cartridge body shall be as specified in IS 1993 or IS/ISO 11951.
- Steel or lightweight metal other than specified in IS: 1993 / ISO: 11949 or IS: / ISO: 11951, may be allowed to use subject to approval from statutory authority.

6.2 Material of Cartridge Stem

The material used for the cartridge stem shall be as follows:

- The material shall have a melting point above 350 °C; and
- It shall be made of corrosion-resistant metal or the surfaces shall be treated for corrosion resistance.

7 PERFORMANCE TESTS

The performance of non-refillable LPG cartridges, when tested by the methods described in 8.3, shall conform to the requirements given in Table 4.

Table 4 Performance
(Clause 7)

SI No.	Item		Performance	Applicable test subclause
(1)	(2)	(3)	(4)	(5)
i)	Gas resistance	Rubber for cartridge	The mass change rate shall not exceed 20	8.3.4

		valve	percent. There shall be no deformation or change that can be detrimental to use.	
ii)	Ozone resistance		There shall be no cracks.	8.3.5
iii)	Gas tightness		There shall be no LPG leakage.	8.3.6
iv)	Pressure resistance	Deformation	There shall be no leakage and deformation.	8.3.7.2
v)		Burst	The cartridge shall not burst.	8.3.7.3
vi)	Stem functioning load		12 N to 19 N	8.3.8
vii)	Cycle test		The requirements for gas tightness shall be met.	8.3.9
viii)	Accuracy of filled LPG mass to the nominal mass		It shall have a tolerance between +1 % and -2 %.	8.3.11
ix)	Initial partial air pressure		It shall not exceed 50 kPa at a temperature of 25 °C.	8.3.13
x)	Valve flow rate		The flow rate shall be 8 l/min or more at the valve-inlet pressure of 0,2 MPa.	8.3.14
xi)	Flange strength		The maximum load before deformation of the edge of the flange notch shall be 100 N or greater.	8.3.15
xii)				

8 TEST METHODS

8.1 Test Condition

Unless otherwise stated, the test conditions shall be as follows:

- a) Ambient temperature: $(20 \pm 15) \text{ }^\circ\text{C}$;
- b) Humidity: (65 ± 20) percent; and
- c) Temperature variation during test: $\pm 5 \text{ }^\circ\text{C}$.

8.2 Test Instruments and Apparatus

Test instruments and apparatus shall be as given in Fig. 3, Fig. 4, and Fig. 5.

8.3 Tests for Construction, Design, Material and Performance

8.3.1 General

Unless otherwise specified in the test subclause, the evaluation of test results shall be performed by visual observation. For the dimensional evaluation in 5.2, the dimension of each part shall be measured using a suitable measuring instrument.

8.3.2 Vibration Test

With the specimen, which has been packed for transportation, fixed horizontally on a vibration tester, apply first vertical vibrations and then lateral vibrations of 5 mm full amplitude at a rate of 600 cycles per minute (CPM) for 30 min. Test for gas tightness according to the method described in 8.3.6 and for pressure resistance according to the method described in 8.3.7.

8.3.3 Drop Test

The drop test shall be as follows:

- a) Drop a cartridge, which has been packed for transportation, from a 1 m height with its top surface facing up onto a concrete floor. Test for gas tightness according to the method described in 8.3.6 and for pressure resistance according to the method described in 8.3.7. Also, examine for deformations detrimental to use;
- b) Drop a cartridge body with its cartridge cap on from a 30 cm height onto a wooden floor, directing the cartridge valve, three times each way: upward, downward and then in the horizontal position, for a total of nine times. After each drop, test for gas tightness according to the method described in 8.3.6 and for pressure resistance according to the method described in 8.3.7. Also, examine for deformations detrimental to use; and
- c) Drop a cartridge with its cartridge cap removed from a 30 cm height onto a wooden floor directing its valve upward. Test for gas tightness according to the method described in 8.3.6 and for pressure resistance according to the method described in 8.3.7. Also, examine for deformations detrimental to use.

8.3.4 Gas Resistance Test

For testing the gas resistance of the rubber of a cartridge valve, measure the mass of a specimen, of which the initial mass has been previously measured, at the time of taking out after leaving in LPG of not less than 95 percent C₄H₁₀ (butane) at a temperature of -10 °C or lower for at least 24 h, and after leaving in LPG of not less than 95 percent, C₄H₁₀ (butane) at a temperature of 40 °C or higher for at least 24 h. Calculate the mass change rate by using formula (1). Also, examine visually for deteriorations or deformations detrimental to use.

$$\Delta M = \frac{M_A - M_B}{M_B} \times 100 \quad \dots(1)$$

where,

ΔM = mass change rate, in percentage;

M_A = mass after testing, in gram; and

M_B = mass before testing, in gram.

8.3.5 *Ozone Resistance Test*

For testing the ozone resistance of the packing of a cartridge valve, subject a cartridge, which has been emptied of the LPG it contained, to the condition of ozone concentration 50 pphm (parts per hundred million parts) and test temperature (40 ± 2) °C for the test duration of 96 h by means of the test apparatus specified in clause 5 of IS 3400 (Part 20) and visually examine for the generation of fissures. Alternately the supplier's certificate for ozone resistance shall be acceptable.

8.3.6 *Gas Tightness Test*

For testing the gas tightness of a cartridge, immerse a cartridge in warm water at a temperature of 48 °C to 50 °C for 30 min or longer and visually examine for LPG leakage from any part of the cartridge. When testing multiple cartridges, this test may be performed by immersion in warm water at a temperature of (55 ± 2) °C for 110 s or longer.

8.3.7 *Pressure Resistance Test*

8.3.7.1 *General*

The pressure resistance test for cartridges shall be given in **8.3.7.2** and **8.3.7.3**.

NOTE — For the purposes of the pressure resistance test, the valve can be removed for the test.

8.3.7.2 *Deformation*

Using the test apparatus given in Fig. 3 or any equivalent apparatus, apply hydraulic or aerostatic pressure to a cartridge which has been emptied of LPG it contained, gradually increase the pressure up to 1.3 MPa and then hold for 30 s. Examine visually for leakage or deformation of any part.

8.3.7.3 *Burst*

Apply a pressure of 1.5 MPa to the cartridge in the same manner as in **8.3.7.2** and see if any part of the cartridge bursts.

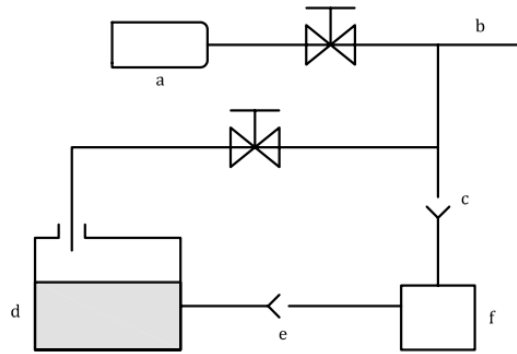

Key

- | | |
|-----------------------|--|
| a Test cartridge | d Water tank |
| b Test pressure gauge | e Check valve |
| c Check valve | f Pressure applying device such as booster pump and intensifier piston |

FIG. 3 HYDRAULIC PRESSURE RESISTANCE TEST APPARATUS

8.3.8 Stem Functioning Load Test

For the functioning load test of the stem, measure the load which is acting on the stem when the stem is pushed in 1.5 mm. The load value shall be the arithmetic mean of five measured values.

8.3.9 Cycle Test

For the cycle test of cartridge valves, after repeating the operation of pushing in the stem to the compressive (stroke) dimension of the cartridge valve for 100 times at a rate of once per second, carry out the test given in 8.3.6 and examine for any leakage. The above procedure shall be performed without discharge of LPG.

8.3.10 LPG Composition

The composition of butane filled in the cartridges shall be predominately Butane (C₄H₁₀) (greater than or equal to 95 percent mass fraction) confirming to IS 4576. The gas supplier certificate shall suffice. Filler shall be responsible for compliance of the subject clause.

8.3.11 Filled LPG Mass Test

For the test of mass of the LPG filled in the cartridge, measure the mass of the cartridge filled with LPG and that of the cartridge emptied of LPG, and calculate the mass of filled LPG by using formula (2):

$$M = M_F - M_E \quad \dots(2)$$

where

M = mass of filled LPG, in gram;

M_F = mass of cartridge filled, in gram; and
 M_E = mass cartridge emptied of LPG, in gram.

8.3.12 Test of compressive (stroke) dimension and initial injection stroke dimension of cartridge valve.

8.3.12.1 *Compressive (stroke) dimension of cartridge valve*

Measure the travelling distance of the stem from the normal state to fully pushed-in state by means of a dial gauge.

8.3.12.2 *Initial injection stroke dimension*

Using the apparatus given in Fig. 4 or any equivalent apparatus, push in the stem gradually and measure the pushed-in dimension of the stem by means of a dial gauge when air bubbles appear intermittently.

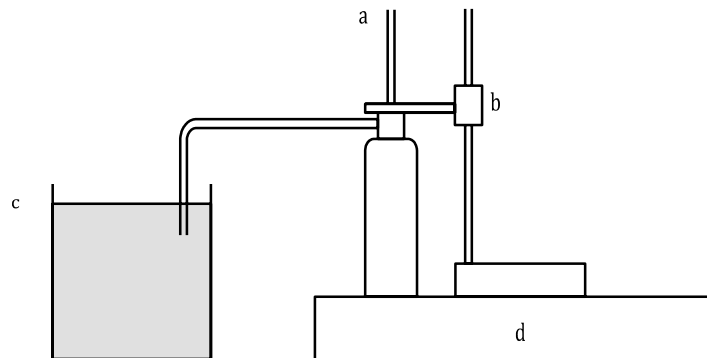

Key
a Dial gauge c Water tank
b Feeding wheel d Surface plate

FIG. 4 INITIAL INJECTION STROKE TEST APPARATUS

8.3.13 *Initial Partial Air Pressure Test*

Immerse a new cartridge which has never discharged LPG in a constant-temperature water tank maintained at $(25 \pm 1)^\circ\text{C}$ for 30 min or longer. Attach a pressure gauge at the end of the stem to measure the initial inner pressure (P_1). Then, with care not to allow discharge of the liquid-phase LPG, push the stem to open the valve, and discharge the LPG for 10 s. Immerse the cartridge in the constant temperature water tank maintained at $(25 \pm 1)^\circ\text{C}$ for 30 min or longer until the temperature has stabilized, and attach a pressure gauge at the end of the stem to measure the inner pressure (P_2) after LPG discharge. Calculate the initial partial air pressure by using formula (3):

$$P = P_1 - P_2 \quad \dots(3)$$

where,

- P = initial partial air pressure, in kPa;
- P_1 = initial inner pressure, in kPa; and
- P_2 = inner pressure after LPG discharge, in kPa.

8.3.14 Valve Flow Rate Test

Connect an apparatus as shown in Fig. 5 to a vacant cartridge and, with the stem pushed in 1.5 mm and the pressure at upstream side of cartridge (valve-inlet pressure) regulated to 0.2 MPa, measure the valve flow rate by air.

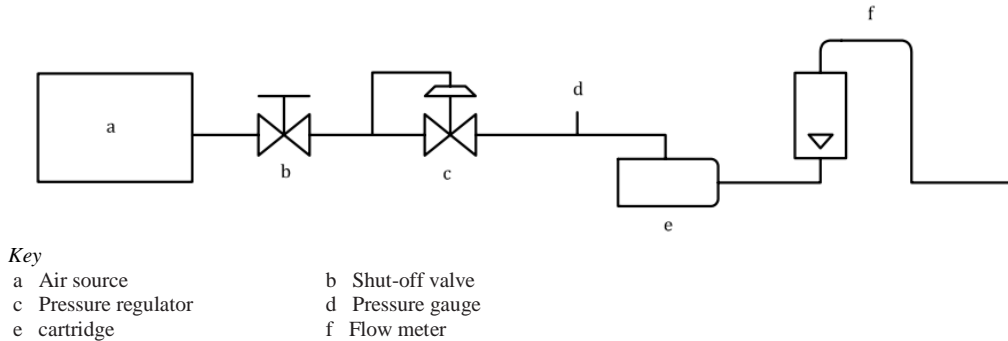
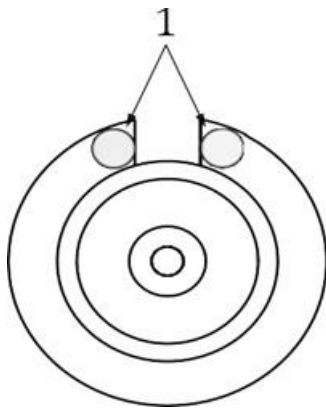

FIG. 5 VALVE FLOW RATE TEST APPARATUS

8.3.15 Flange Strength Test

Stand the cartridge and, using a circular jig of 3.5 mm diameter positioned as shown in Fig. 6, depress the flange gradually in the vertical direction. Measure the maximum load (N) before the flange is deformed to reach the cartridge body. Test at both edges of the flange notch.



TOP VIEW OF FLANGE

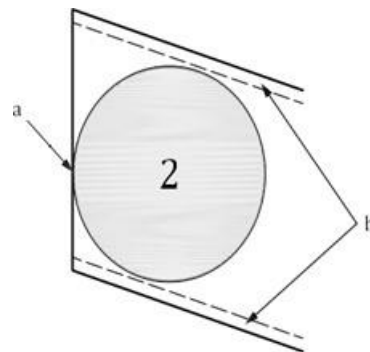

FLANGE NOTCH PART ENLARGEMENT

Key

- | | |
|--------------------------|-----------------------------------|
| 1 Circular jig | 2 Circular jig 3.5 mm in diameter |
| a Align at the end face. | b Bend part. |

NOTE — This is an example illustrating one of the edges of the flange notch. The jig shall be placed at the centre of the flange width, which excludes the bends on both sides of the flange.

FIG. 6 MEASUREMENT DIMENSION OF FLANGE STRENGTH

9 TEST FREQUENCY

SI No.	Inspection Item				Inspection by Testing Agency		Inspection By Factory
					Type Inspection (Conducted At Testing House Lab)	Follow Up Inspection (Conducted On Sight)	
					(Pcs)	(Pcs)	(Pcs/lot)
(1)	(2)	(3)	(4)	(5)	(6)	(7)	(8)
i)	4	Gas filled in cartridge	4.1	Composition	1	1	1
ii)			4.2	Nominal LPG capacity			
iii)				1) Nominal LPG capacity	1	3	1 per filling head
iv)				2) Accuracy of filled LPG mass to the nominal mass	3	3	9 All (filled cartridge weight)
v)			4.3	Odour	1		1
vi)	5	Construction and design	5.1	Pressing jointed part	1		
vii)			5.1	Vibration test	1		
viii)			5.1	Drop test	1		
ix)			5.1	Gaseous state	1		9
x)			5.1	Means to prevent LPG from being discharged	1		
xi)			5.1	Means to protect the protruding	1		

				cartridge valve			
xii)			5.2.1	Dimensions of cartridge each part	10	3	9
xiii)			5.2.2	Compressive (stroke) dimension and initial injection stroke dimension of cartridge valve	10		3
xiv)	6	Material	6.1	Material of cartridge body	1		
xv)			6.2	Material of cartridge stem	1		
xvi)	7	Performance	Table 4 Sl No. (i)	Gas resistance	3		
xvii)			Table 4 Sl No. (ii)	Ozone resistance	3		
xviii)			Table 4 Sl No. (iii)	Gas tightness	10	10	All
xix)			Table 4 Sl No. (iv) and (v)	Pressure resistance	3	3	3
xx)			Table 4 Sl No. (vi)	Stem functioning load	3		5
xxi)			Table 4 Sl No. (vii)	Cycle test	3		2
xxii)			Table 4 Sl No. (ix)	Initial partial air pressure	3		
xxiii)			Table 4 Sl No. (x)	Valve flow rate	3		
xxiv)			Table 4 Sl No. (xi)	Flange strength	10		
xxv)							
xxvi)	9	Marking			1	1	9

10 MARKING

10.1 A cartridge for gas appliances satisfying all the requirements in this document shall be indelibly marked at a noticeable place with the following information:

- a) Caution against fire and high temperature;
- b) Text explaining that, since a non-refillable LPG cartridge is a dangerous flammable product using high pressure gas, the following shall be observed in its use:
 - 1) Do not burn charcoal on the gas appliances, or use two or more gas appliances by placing them side by side;
 - 2) Since an elevation in temperature can cause bursting of the product, avoid putting the cartridge in any place exposed to direct sunlight or near the fire where the temperature can become 40 °C or higher;
 - 3) Do not put into fire;
 - 4) Make sure the cartridge has been used up before disposing;
 - 5) Do not refill the gas; and
 - 6) Do not place on an induction cooker (using on an induction cooker is strictly prohibited);
- c) For high pressure gas, the type of gas used;
- d) The name of the cartridge;
- e) Information related to the installation of the cartridge;
- f) Information related to the storage of the cartridge;
- g) Information related to the handling of the used-up cartridge;
- h) Information related to the appliance which the cartridge is to be used;
- j) Information related to the filled LPG;
- k) Information related to the cautionary marking of an incorrect installation;
- m) Information related to the caution against overheating the cartridge;
- n) Information related to the danger of inhalation;
- p) Information related to the ventilation and the using space;
- q) The name of cartridge manufacturer, an abbreviation or monogram thereof;
- r) The name of gas filling works, an abbreviation or monogram thereof;
- s) The year and month of manufacture or an abbreviation thereof;
- t) Batch number in DDMMYYYY format, which is cartridge filling date; ;
- u) Number of this Indian Standard;
- v) Inspecting agency's official mark;
- w) Name of gas.

10.2 BIS Certification Marking

The product(s) conforming to the requirements of this standard may be certified as per the conformity assessment schemes under the provisions of the *Bureau of Indian Standards Act, 2016*

and the Rules and Regulations framed thereunder, and the product(s) may be marked with the Standard Mark.