प्रकाशिकी और फोटोनिक्स — सूक्ष्म लेंस
सरणियाँ

भाग 4 ज्यामितीय गुणधर्मों की परीक्षण पद्धतियाँ

Optics and Photonics — Microlens
Arrays

Part 4 Test Methods for Geometrical
Properties

ICS 31.260

© BIS 2024

© ISO 2006



भारतीय मानक ब्यूरो

BUREAU OF INDIAN STANDARDS

मानक भवन, 9 बहादुर शाह ज़फर मार्ग, नई दिल्ली - 110002

MANAK BHAVAN, 9 BAHADUR SHAH ZAFAR MARG

NEW DELHI - 110002

www.bis.gov.in www.standardsbis.in

August 2024

Price Group 10

NATIONAL FOREWORD

This Indian Standard (Part 4) which is identical to ISO 14880-4 : 2006 'Optics and photonics — Microlens arrays — Part 4: Test methods for geometrical properties' issued by the International Organization for Standardization (ISO) was adopted by the Bureau of Indian Standards on the recommendation of the Optics and Photonics Sectional Committee and approval of the Production and General Engineering Division Council.

This standard specifies methods of testing optical properties, other than wavefront aberrations, of microlens arrays. Examples of applications for microlens arrays include three-dimensional displays, coupling optics associated with arrayed light sources and photo-detectors, enhanced optics for liquid crystal displays, and optical parallel processor elements.

This standard has been published in five parts. The other parts in this series are:

- Part 1 Vocabulary
- Part 2 Test methods for wave front aberrations
- Part 3 Test methods for optical properties other than wave front aberrations
- Part 5 Guidance on testing

The text of ISO standard has been approved as suitable for publication as an Indian Standard without deviations. Certain conventions are, however, not identical to those used in Indian Standards. Attention is particularly drawn to the following

- a) Wherever the words 'International Standard' appear referring to this standard, they should be read as 'Indian Standard';
- b) Comma (,) has been used as a decimal marker while in Indian Standards, the current-practice is to use a point (.) as the decimal marker.

In this adopted standard, reference appears to the following International Standard for which Indian Standard also exists. The corresponding Indian Standard which is to be substituted in its place is given below along with its degree of equivalence for the edition indicated.

<i>International Standard</i>	<i>Corresponding Indian Standard</i>	<i>Degree of Equivalence</i>
ISO 14880-1 Optics and photonics — Microlens arrays — Part 1: Vocabulary	IS 18726 (Part 1) : 2024/ ISO 14880-1 : 2019 Optics and photonics — Microlens arrays: Part 1 Vocabulary	Identical

For the purpose of deciding whether a particular requirement of this standard is complied with, the final value, observed or calculated expressing the result of a test or analysis, shall be rounded off in accordance with IS 2 : 2022 'Rules for rounding off numerical values (*second revision*)'. The number of significant places retained in the rounded off value should be the same as that of the specified value in this standard.

Contents

Page

Introduction	iv
1 Scope	1
2 Normative references	1
3 Terms, definitions and symbols	1
4 Coordinate system.....	3
5 Test methods.....	4
5.1 Pitch and surface modulation depth measurement.....	4
5.2 Physical thickness.....	9
5.3 Radius of curvature	9
5.4 Surface preparation of microlens array for measurement	12
6 Procedure	13
6.1 Measurement of pitch and surface modulation depth (lens sag)	13
6.2 Measurement of physical thickness	13
6.3 Measurement of radius of curvature.....	13
7 Results and uncertainties	13
8 Test report	14
Annex A (normative) Measurement with a Fizeau interferometer system	16
Annex B (informative) Uniformity of array spacing	19
Bibliography	22

Introduction

This part of ISO 14880 specifies methods for testing geometrical properties of microlens arrays. Examples of applications for microlens arrays include three-dimensional displays, coupling optics associated with arrayed light sources and photo-detectors, enhanced optics for liquid crystal displays, and optical parallel processor elements.

The market in microlens arrays has generated a need for agreement on basic terminology and test methods. Standard terminology and clear definitions are needed not only to promote applications but also to encourage scientists and engineers to exchange ideas and new concepts based on common understanding.

This part of ISO 14880 contributes to the purpose of the series of ISO 14880 standards, which is to improve the compatibility and interchangeability of lens arrays from different suppliers and to enhance development of the technology using microlens arrays.

The measurement of physical characteristics of pitch and surface modulation depth can be made using a stylus instrument and non-contact optical probe system. Physical thickness can be measured with a micrometer. The measurement processes are described in the body of this part of ISO 14880.

Indian Standard

OPTICS AND PHOTONICS — MICROLENS ARRAYS
PART 4 TEST METHODS FOR GEOMETRICAL PROPERTIES

1 Scope

This part of ISO 14880 specifies methods for testing geometrical properties of microlenses in microlens arrays. It is applicable to microlens arrays with very small lenses formed on one or more surfaces of a common substrate and to graded index microlenses.

2 Normative references

The following referenced documents are indispensable for the application of this document. For dated references, only the edition cited applies. For undated references, the latest edition of the referenced document (including any amendments) applies.

ISO 14880-1, *Optics and photonics — Microlens arrays — Part 1. Vocabulary*

3 Terms, definitions and symbols

For the purposes of this document, the terms, definitions given in ISO 14880-1 and the following apply.

NOTE 1 The symbols adopted for this part of ISO 14880 are chosen for clarity in this application to microlens arrays but some may not be those commonly used for surface texture measurement.

NOTE 2 The parameters P_x , P_y and h are used in this part of ISO 14880 to describe geometrical parameters encountered in the measurement of surface texture. P_x , P_y are spacing parameters and are defined as the average value of the length of the mean line section containing a profile peak and adjacent valley. An amplitude parameter, h , is defined as the average difference between peak of the lens profile and the rim. Figure 1 illustrates the geometrical properties of microlens arrays which are to be measured.

3.1

pitch

P_x, P_y

distance between the centres of adjacent lenses which may vary across and will vary with direction

See Figure 1.

NOTE 1 The pitch is expressed in millimetres.

[ISO 14880-1:2001, term 6.2.1.5]

NOTE 2 For a stylus instrument this will generally equate to the mean width of the profile elements calculated from the roughness profile, RS_m (see 3.2.2 and 4.3.1 in ISO 4287:1997).

3.2
surface modulation depth

h

peak-to-valley variation of the surface height

See Figure 1.

NOTE 1 For a purely refractive microlens, this will be the same as the lens sag.

NOTE 2 The surface modulation depth is expressed in millimetres.

[ISO 14880-1:2001, term 6.2.1.8]

NOTE 3 For stylus instruments this will generally equate to R_z (see 4.1.3 in ISO 4287:1997).

3.3
physical thickness

T_c

maximum local thickness of the array

See Figure 1.

NOTE The physical thickness is expressed in millimetres.

[ISO 14880-1:2001; term 6.2.1.9]

3.4
radius of curvature

R_c

distance from the vertex of the microlens to the centre of curvature of the lens surface

See Figure 1.

NOTE 1 The radius of curvature is expressed in millimetres.

[ISO 14880-1:2001; term 6.1.4]

NOTE 2 For rotationally invariant microlenses or cylindrical microlenses.

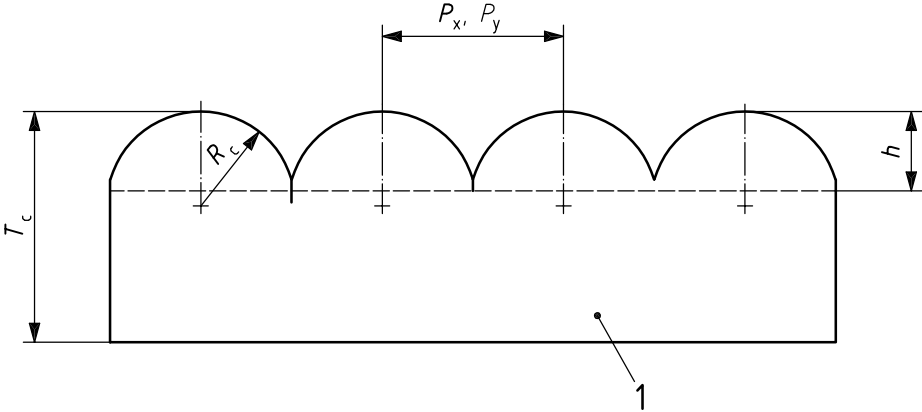

- Key**
- 1 substrate
 - T_c physical thickness
 - R_c radius of curvature
 - P_x, P_y pitch
 - h surface modulation depth (lens sag)

Figure 1 — Geometrical parameters of microlens arrays

4 Coordinate system

To measure the geometrical properties of a microlens array, a Cartesian coordinate system is used, as shown in Figure 2. In a right-handed Cartesian set, the x- and y-axis lie in the substrate plane and the x-axis provides the direction of trace. The z-axis is the outward direction from the material to the surrounding medium.

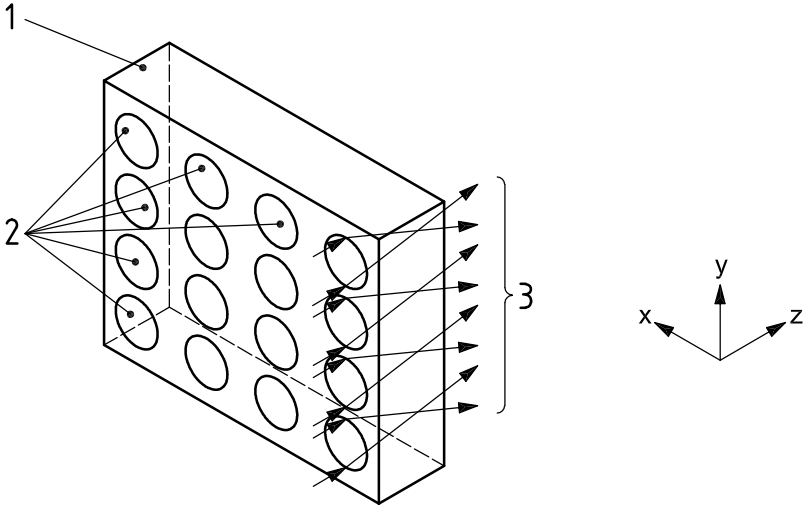

- Key**
- 1 substrate
 - 2 microlens
 - 3 light pass

Figure 2 — Microlens array with a Cartesian coordinate system

5 Test methods

5.1 Pitch and surface modulation depth measurement

5.1.1 Use of stylus instrument

5.1.1.1 Principle

The basic principle using a stylus instrument is to obtain a profile of the surface of the array. Care shall be taken to ensure that the profile passes through the centre of each lens and that the stylus remains in contact with the surface throughout the measurement process. This enables the pitch and surface modulation depth to be determined.

5.1.1.2 Set-up and preparation

The measurement of the geometrical characteristics of a microlens array is similar in principle to the measurement of any surface using a stylus instrument. A typical stylus instrument consists of a stylus that physically contacts the surface and a transducer to convert its vertical movement into an electrical signal. Other components can be seen in Figure 3 and include the following: a pick-up, driven by a motor and gearbox, which draws the stylus over the surface at a constant speed; an electronic amplifier to boost the signal from the stylus transducer to a useful level; a device for recording the amplified signal or a computer that automates the data collection.

The part of the stylus in contact with the surface of the array is usually a diamond tip with a carefully manufactured profile. Owing to their finite shape, some styli on some arrays may not penetrate into valleys and will give a distorted or filtered measurement of the surface. The effect of the stylus forces can have a significant influence on the measurement results. Too high a force can cause damage to the surface of the array. Too low a force and the stylus will not stay reliably in contact with the surface.

The stylus instrument shall be used in an environment that is as free as possible from dust, vibration and direct sunlight in a location where the ambient temperature is maintained in the range $20\text{ °C} \pm 5\text{ °C}$ (with a condensation-free humidity below 70 % relative humidity). Remove any gross contamination from the surface of the instrument preferably by blowing the surface with filtered air. Any oil or grease may be removed using a suitable solvent.

Due consideration shall be given for testing under more adverse conditions.

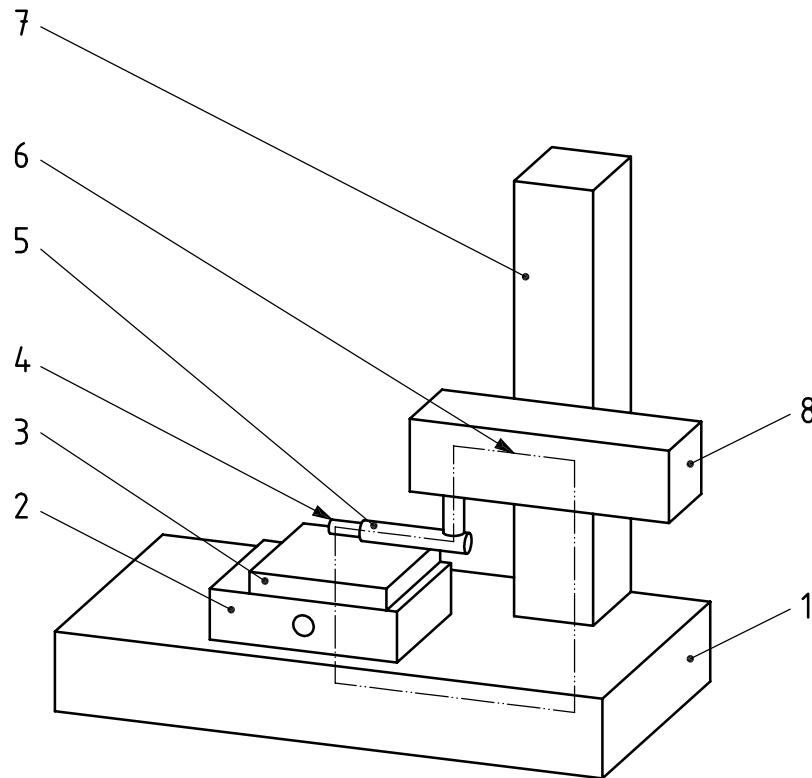

Key

- 1 base
- 2 fixture
- 3 microlens under test
- 4 stylus
- 5 probe (pick-up)
- 6 measurement loop
- 7 column
- 8 drive unit

Figure 3 — Elements of a typical stylus instrument

The electrical unit on the stylus instrument shall be switched on at least one hour before any measurements take place. This will allow time for the instrument to stabilize (the manufacturer's instructions will normally specify a minimum stabilization time for a given instrument). Calibration of the instrument is essential prior to measurement. Before calibration of the instrument takes place the stylus should be checked for signs of wear or damage. A damaged stylus tip can lead to serious errors.

After measurement of the calibration artefact the indicated value shall be compared with the value attached to the test object. If the measured value differs from the value that is shown on the calibration certificate then re-calibration is required.

5.1.1.3 Stylus size and shape

It is important that the dimension and shape of the stylus are chosen appropriately as this can affect the accuracy of the traced profile in a number of ways. On arrays with deep, narrow valleys the stylus may not be able to penetrate fully to the bottom because either the tip radius or the flank angle of the stylus is too large. In such cases, the value of the surface modulation depth will be smaller than the true value. The ideal stylus shape is a cone with a spherical tip. This usually has a cone angle of either 60° or 90° with a typical tip radius of 1 µm, 2 µm, 5 µm or 10 µm.

5.1.2 Use of confocal microscope

5.1.2.1 Principle

The confocal principle can be used for the measurement of surface topography. Depth is discriminated by moving the surface of the object through focus and measuring the reflected intensity using a detector and confocal pinhole. When the object point lies at the focus, the maximum intensity is detected whereas the signal is reduced when the object point is displaced from the focus. The principle has been established in the scanning confocal microscope. By scanning an imaged light spot over the object an area is measured point by point.

5.1.2.2 Set-up and preparation

The principle of the confocal microscope has been developed by generating an array of light spots on the object using a multiple pinhole mask (Nipkow disc) which allows for parallel data acquisition of multiple object points. The Nipkow disc can be replaced by a microlens array in order to improve the light efficiency, as shown in Figure 4.

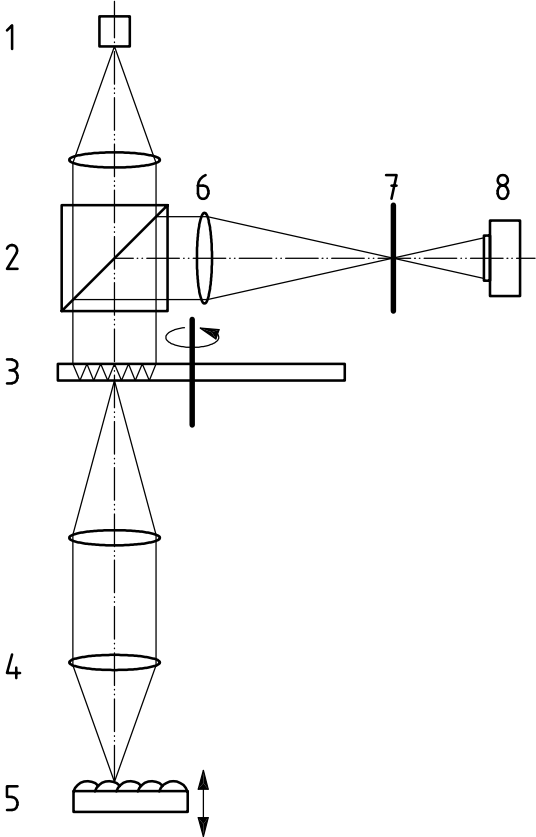

Key

- 1 light source
- 2 beam splitter
- 3 rotating microlens disc (analogue to a Nipkow disc)
- 4 objective
- 5 sample
- 6 imaging lens
- 7 pinhole
- 8 detector

Figure 4 — Confocal microscope measurement System A

Figure 5 shows another configuration of the confocal microscope using a microlens array and a pinhole array. It will enhance the optical radiation collection efficiency and improve the scanning speed, which depends on the pinhole array with parallel scanning. An example of a measurement is shown in Figure 6.

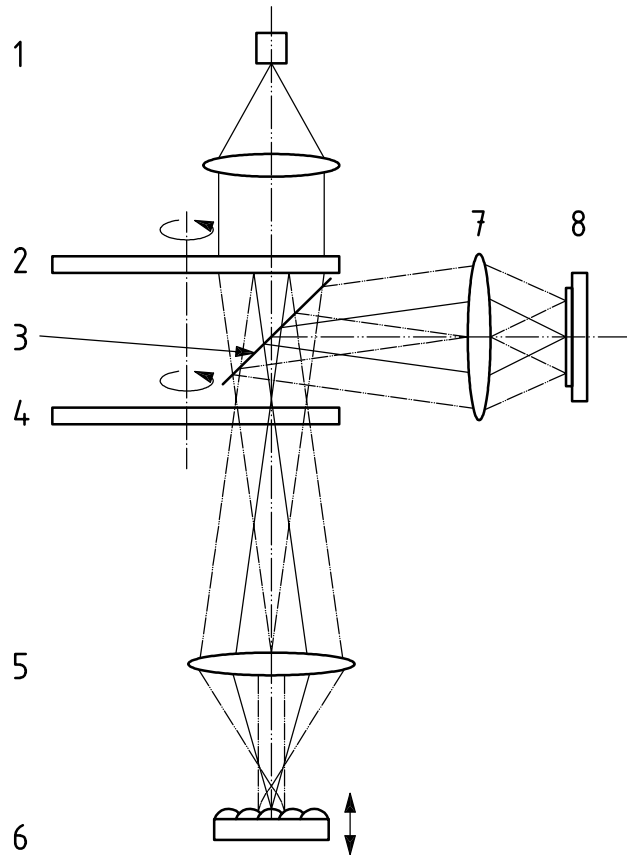

Key

- 1 light source
- 2 rotating microlens disc
- 3 beam splitter
- 4 pinhole array (Nipkow disc)
- 5 objective
- 6 sample
- 7 imaging lens
- 8 charge-coupled device (CCD) camera

Figure 5 — Confocal microscope measurement System B

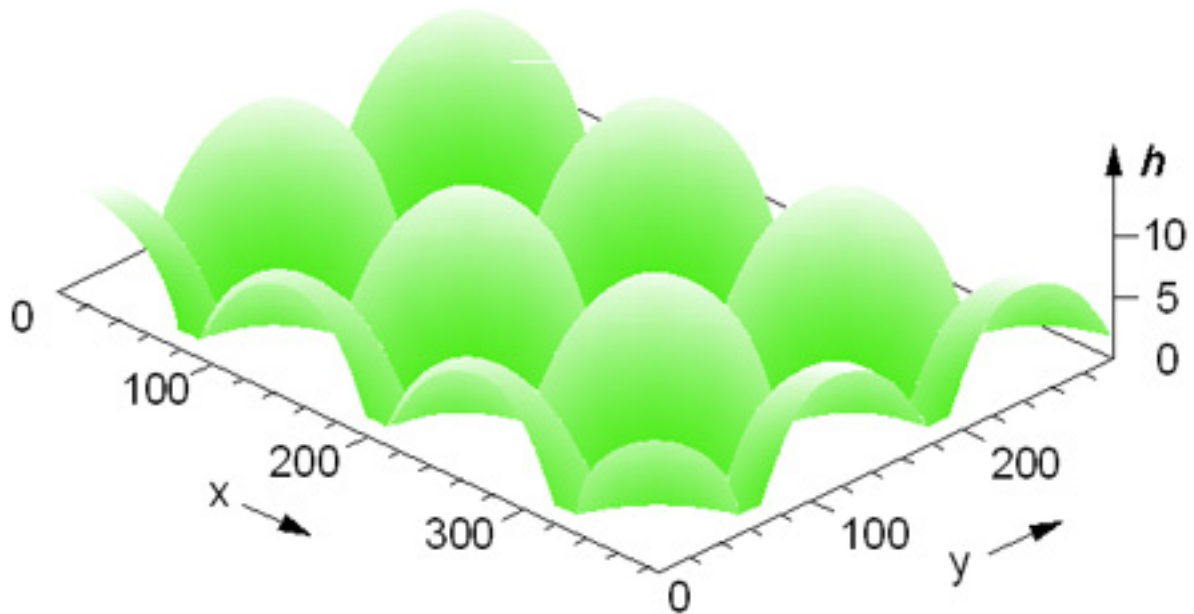

Figure 6 — Example of the microlens array surface structure using a confocal microscope measurement system

5.2 Physical thickness

5.2.1 Principle

The two anvils of the micrometer contact the top and bottom surfaces of the array to measure the physical thickness of the array at a given point. The anvils of the micrometer may be parallel or spherical.

5.2.2 Set-up and preparation

The micrometer shall be calibrated using a gauge block or a similar procedure prior to the measurement. Thoroughly wipe the spindle and the measuring faces of the micrometer using clean lint free paper or cloth. Leave the instrument and the microlens array long enough to adjust to room temperature (at least 1 h). Care shall be taken to ensure that the micrometer is not subject to sudden temperature changes, direct sunlight, radiant heat or air currents that may cause significant temperature variations.

5.3 Radius of curvature

5.3.1 Principle

The basic principle is to locate, by optical means as shown in Figure 7, the vertex of the microlens under test. The displacement necessary to locate the focal position or the centre of curvature of the surface is then measured. This enables the radius of curvature R_c to be determined respectively. Care shall be taken to avoid incorrect settings b) and c) as shown in Figure 7.

NOTE It is only possible to locate the centre of curvature of the test surface using this method if the lens surface is spherical. Otherwise light is not retroreflected to form a confocal image. If it is suspected that the test surface is not spherical, the shape can be estimated from a zonal analysis using interferometry.

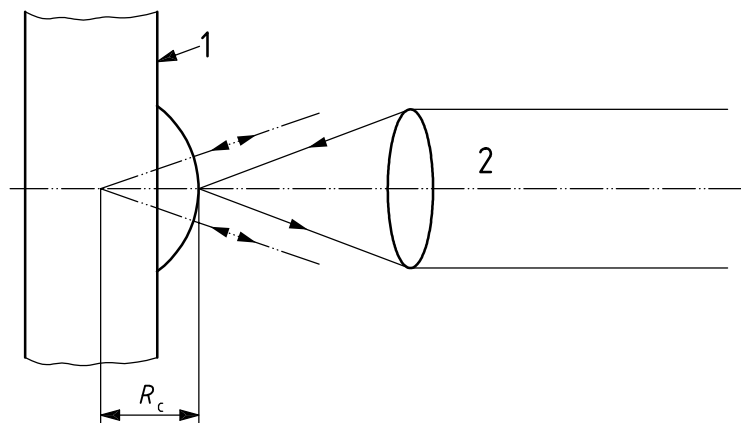

a) Example of correct setting

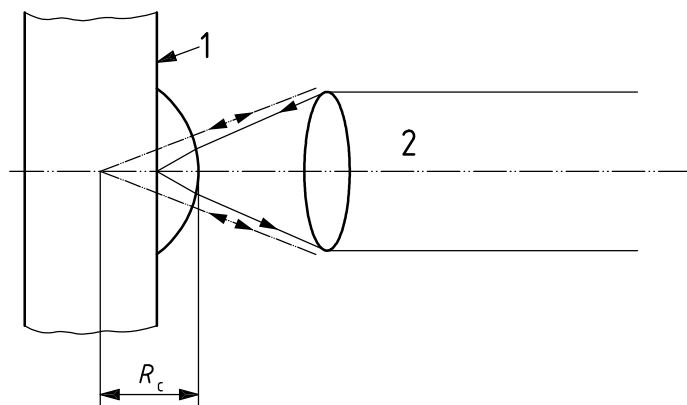

b) Example of incorrect setting

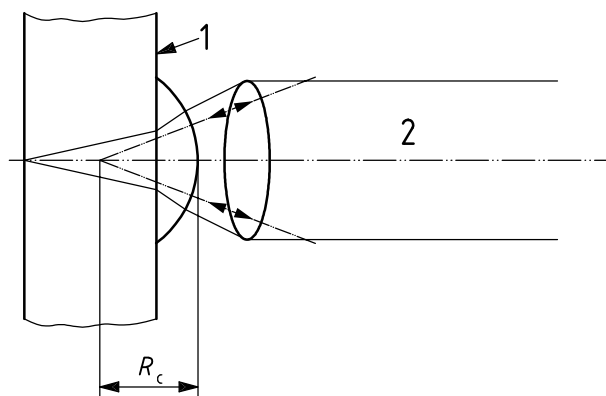

c) Example of incorrect setting

Key

- 1 substrate surface
- 2 optical probe
- R_c radius of curvature

Figure 7 — Location of the centre of curvature and the spherical lens surface with an optical probe

5.3.2 Measurement arrangement and test equipment

5.3.2.1 General

The testing of microlenses is similar in principle to testing larger lenses. In many cases however, the measurement of very small lenses presents practical problems, which make it difficult to use standard equipment. In general, two optical techniques can be used. One is based on microscopy, the other is based on interferometry.

- a) The first technique uses a microscope fitted with a displacement transducer, suitable light source, test object, microscope video camera, monitor and image analyser (line intensity scan). This microscope is used to locate, by focusing, the vertex of the microlens. The radius of curvature is deduced from a measurement of the displacement necessary to reposition the microscope and locate the centre of curvature of the surface as in Figure 8.

A focusing aid in the microscope such as a split-field focusing graticule enables the featureless vertex of a microlens to be more readily located when viewing with reflected light. The position of the centre of curvature may be located when the microscope is focused close to the centre because a confocal image is formed by retroreflection of the rays at near-normal incidence on the lens surface. Tests may be performed in white light or monochromatic illumination.

- b) The second technique uses interferometry to generate interference patterns that indicate the location of the test surface or the centre of curvature. The test interferometer may be one of several types, for example a Fizeau, a lateral shearing or Twyman-Green. These are more fully described in ISO 14880-2 and ISO/TR 14999-1. One advantage of interferometry is that for strongly aberrated lenses, the variation in radius of curvature with aperture radius can be readily deduced from the interference patterns. Interferometry is sensitive to small variations in optical path lengths and it is usually necessary to mount the interferometer on an anti-vibration table and to minimize air-borne disturbances.

Clauses 5 to 8 concentrate on the microscope technique while an interferometric technique is described in Annex A.

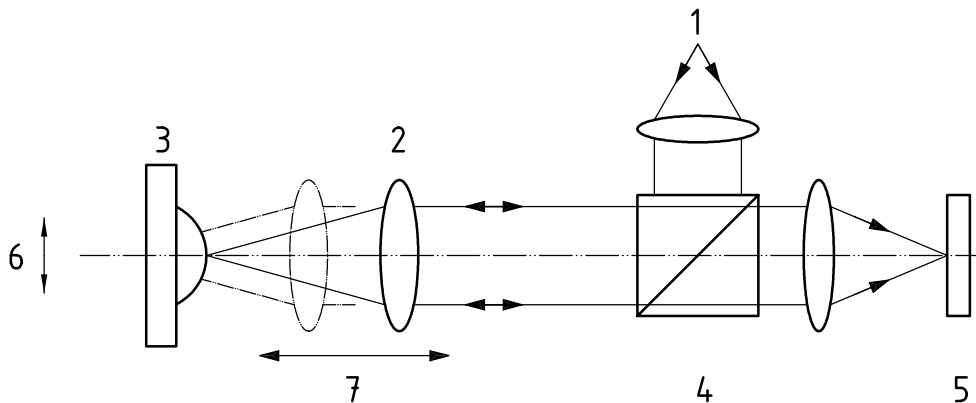

Key

- 1 source to illuminate lens surface
- 2 microscope objective
- 3 microlens under test
- 4 beam splitter
- 5 CCD-camera
- 6 lateral (x, y) adjustment to centre microlens
- 7 axial (z) adjustment of microscope to locate lens vertex and centre of curvature

Figure 8 — Microscope used to measure the radius of curvature of the microlens surface

5.3.2.2 Test system

5.3.2.2.1 Microscope

A microscope fitted with a focusing aid such as a split-image rangefinder is used to enable focus settings to be made on featureless surfaces and to enable the centre of curvature to be located by confocal imaging. The displacement of the test surface relative to the microscope objective is measured with a calibrated displacement transducer.

Note that the area of the lens surface sampled for the radius measurement is limited by the NA (numerical aperture) of the microscope objective.

5.3.2.2.2 Light source

A light source emitting radiation either in a large band of wavelengths, such as an incandescent source, or at a specific wavelength is suitable for this test.

5.3.2.2.3 Image display

If the image generated by the microscope is relayed by a video camera to a TV display, an electronic intensity display can be used to assist in locating the position of best focus. The resolution of the imaging system shall be sufficient to enable the best focus image to be identified.

5.3.2.2.4 Standard spherical surface

A spherical surface of known radius of curvature shall be used as a reference artefact to verify the performance of the measurement system. A typical value for the departure from sphericity shall be less than $\lambda/2$ root mean square deviation. The radius of the artefact should be similar to the radius of the test object.

5.3.2.3 Preparation

For consistent results the test equipment shall be maintained in a temperature-controlled environment, preferably 20 °C, and not exposed to vibration.

5.4 Surface preparation of microlens array for measurement

For consistent results the test equipment shall be maintained in a temperature-controlled environment, preferably at 20 °C and not exposed to vibration.

The optical surfaces to be tested shall be clean. Uncoated glass surfaces may be safely cleaned with alcohol and cotton wool. The cotton wool should be soaked in a very small amount of solvent before touching the surface and wiped only once across the optical surface before being discarded. This minimizes the chances of scratching the surface. Dust may be removed using a clean camel-hair brush or filtered compressed air.

Coated optical surfaces such as antireflection surfaces should be treated with great care and not cleaned unless absolutely necessary. They may be dusted using filtered compressed air.

Guidance should be sought on the correct use of solvents and cleaning materials.

6 Procedure

6.1 Measurement of pitch and surface modulation depth (lens sag)

6.1.1 Preliminary measurements

Standard instrument calibration procedures shall be carried out [7] [8]. An axis of the lens array shall be aligned to the lateral (x, y) scan direction of the measuring stylus and within the vertical working range of the instrument. A preliminary measurement should be made on the array in order to assess the surface profile. Adjustments in position and level of the array shall be made to ensure that the stylus scans across the centre of each lens and is within the working range of the instrument. It should be noted that the measurements cannot be made if the level of the array is not within the instrument range. It may be necessary to make a number of measurements across the surface of the array and make fine adjustments to its position to ensure correct alignment of the array.

The appropriate measurement parameters (machine speed, frequency, etc.) have to be selected. These will depend on the instrument and reference should be made to the appropriate operating manual. A roughness filter should not be used. The sampling distance, the distance travelled by the stylus across the surface, will be the same as the evaluation length and should be chosen to ensure that a significant number of peaks, not less than 10, form the profile.

6.1.2 Making measurements and interpreting the results

A significant number of profile traces shall be made evenly distributed across the surface of the array (avoiding any defects) along both the x- and y-axis near the lens vertices. After the measurements have been taken a possible tilt shall be corrected by a linear fit. This should be done via the instrument software prior to the calculation of any parameters. The P_x , P_y (pitch) and h (surface modulation depth) parameters in x- and y-directions across the array shall be calculated according to the appropriate ISO standards.

6.2 Measurement of physical thickness

The micrometer shall be calibrated prior to the measurement using a gauge block or a similar artefact. Select the micrometer that best fits the application. Care shall be taken to ensure the measurements are made at the centre of a lens and that parallax errors are minimized. At least 10 measurements shall be made evenly distributed over the microlens array.

6.3 Measurement of radius of curvature

Verify the performance of the test system by measuring the radius of curvature of a spherical reference artefact. The radius of the calibration artefact should be similar to the radius of the microlens to be measured.

The measurement is carried out by focusing the microscope on the test surface vertex and then refocusing at the centre of curvature of the surface as shown in Figure 8. At the second position, the confocal position, the microscope objective illuminates the surface at normal incidence and the rays are reflected back on themselves. The confocal image of a graticule or split-image focusing device in the microscope enables the centre of curvature to be located.

The test surface is laterally aligned with the optical axis of the microscope by successive adjustments until the confocal image is centred.

The radius of curvature is the axial displacement between the two test positions.

7 Results and uncertainties

The mean value of a set of measured values for radius of curvature shall be calculated and recorded. The variance of the set of measured values shall be analysed statistically and the unbiased estimate of the standard deviation evaluated. This is to ascertain the Type A contribution to the expanded uncertainty (see Reference [9]).

Typical sources of uncertainty are included in Table 1.

Table 1 — Uncertainty considerations

Origin	Type	Uncertainty limit
Radius of curvature measurement	A	Calculated from a set of, typically nine, measurements
Calibration	A/B	Varies with instruments and method of calibration

A calibration factor will correct for the cosine error and Abbe error and is determined through the calibration procedure. The uncertainty estimation may be either Type A or Type B [9]. Optimum measurement conditions can be selected by monitoring the temperature and relative humidity during the measurements, and always giving the apparatus time to reach room temperature. The Abbe offset error is minimized by arranging for the displacement transducer to measure as close to the optical axis as possible.

The mean value of the sets of measured values, together with the standard errors of the mean (SEOM), shall be calculated and recorded.

The combined standard uncertainty shall be calculated by adding the standard error of the mean of the repeated measurements across the surface of the array in quadrature with the standard uncertainty due to the instrument.

8 Test report

The test results shall be recorded and shall include the following information if applicable:

- a) General information:
 - 1) test has been performed in accordance with ISO 14880-4:2006;
 - 2) date of calibration, calibration procedure and calibration uncertainty assessment;
 - 3) date of test;
 - 4) name and address of test organization;
 - 5) accreditation (if relevant);
 - 6) name of individual performing the test.
- b) Information about the lens under test:
 - 1) lens type;
 - 2) manufacturer;
 - 3) manufacturer's model;
 - 4) serial number.
- c) Test conditions:
 - 1) test method used;
 - 2) test equipment:
 - i) stylus instrument; manufacturer and model,
 - ii) micrometer; manufacturer and model;

- 3) measurement parameters:
 - i) stylus radius,
 - ii) instrument speed,
 - iii) sampling frequency,
 - iv) sampling length;
 - 4) ambient conditions at time of measurement:
 - i) temperature,
 - ii) relative humidity.
- d) Test results:
- 1) pitch;
 - 2) surface modulation depth;
 - 3) physical thickness;
 - 4) radius of curvature;
 - 5) uncertainty table.

Annex A (normative)

Measurement with a Fizeau interferometer system

A.1 Measurement arrangement and test equipment

Radius of curvature may be measured using an interferometer to help locate the vertex of the lens surface and to find the confocal position, using a linear displacement transducer for length measurement. One of the following devices could be used for this purpose:

- Fizeau interferometer;
- Twyman-Green interferometer;
- lateral shearing interferometer; or
- Shack-Hartmann device.

Use of a Fizeau interferometer as shown in Figure A.1, is described here as an example. A collimated beam from a spatially and temporally coherent light source is partially reflected from a plane reference surface to generate a reference wavefront. The transmitted light is focused to a spot by a high quality lens and this spot is used to probe the position of the lens surface and the centre of curvature. Interference patterns are monitored to determine the exact locations.

In principle, interferometers designed for testing macro-sized lenses, a Fizeau interferometer for example, may appear suitable for measurements of microlenses. In practice, however, problems may arise from stray reflections from secondary surfaces in close proximity to the surface under test. The relatively high magnification needed may lead to difficulties in focusing on the exit pupil of the focusing lens. Interferometers specially designed for microlenses overcome these problems.

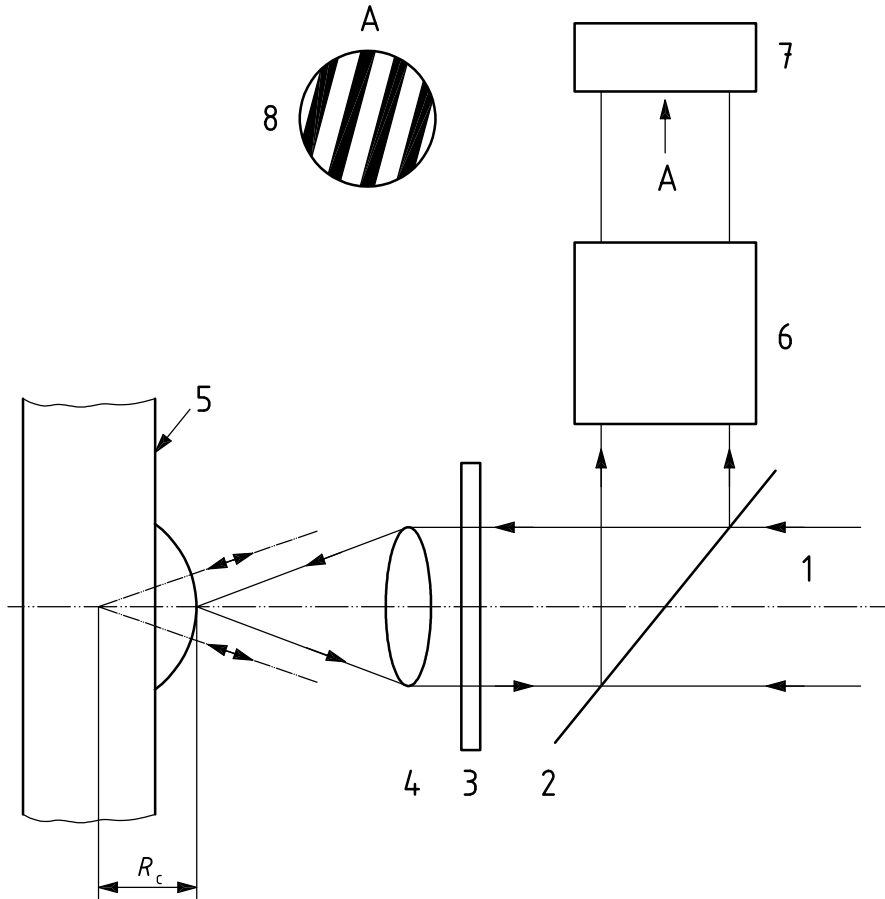

Key

- 1 collimated light
- 2 beam splitter
- 3 reference surface
- 4 focusing lens
- 5 test surface
- 6 telescopic imaging system
- 7 CCD-camera
- 8 interference pattern
- R_c radius of curvature

Figure A.1 — Fizeau interferometer

A.2 Measurement of radius of curvature

The test lens is first moved to a position at which the centre of curvature of the microlens coincides with the focus of the interferometer beam. The illumination is then at normal incidence to the surface and is partially retro-reflected back through the system to form an interference pattern. The position of the lens is then adjusted to produce interference bands that are nominally either straight, parallel and equidistant or the pattern is nulled.

Then the microlens is moved along the z-axis (optical axis) until the beam focus is coincident with the microlens surface. In this position, the light is partially reflected in the cat's-eye configuration back to the interferometer to combine with a reference beam and form a pattern of interference bands. The lens position is adjusted such that the bands are either nominally straight parallel and equidistant or the intensity becomes uniform.

The radius of curvature is the axial displacement of the test lens between the two positions described above. The displacement measurements may be conveniently made with a laser length-measuring interferometer.

NOTE In practice, totally straight interference bands will rarely be obtained. The effect of aberration in the lens under test will be to introduce a degree of curvature that will vary over the field. Residual aberration in the test system may also be apparent especially when using the cat's eye configuration, which inverts one wavefront with respect to the other.

Annex B (informative)

Uniformity of array spacing

B.1 Uniformity of array geometry

One way of testing the uniformity of the array geometry is to test against a master array of known quality. A relatively quick and simple test is to align the test and reference arrays so as to form a moiré pattern.

A moiré pattern occurs when an array of lenses is used to view an array of identical lenses situated at the focal plane of the lenses. As the master lens array is aligned with the test object array, a moiré pattern is observed in which each moiré fringe consists of a magnified image of the repeat element of the object array. As the arrays are rotated with respect to each other the magnification and orientation of the moiré pattern changes. The two arrays have a similar geometry if it is possible to “fluff-out” the moiré fringes. It is necessary to arrange the viewing direction to be normal to the plane of the array to avoid errors due to parallax, as in Figure B.1.

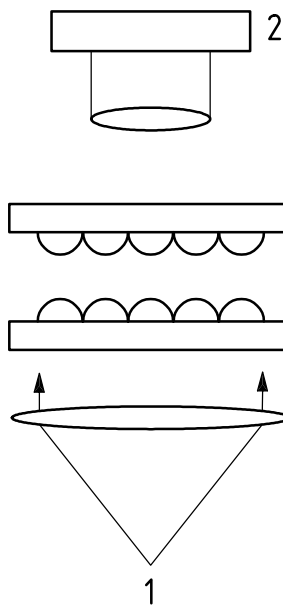

Key

- 1 light source
- 2 camera or viewing system

Figure B.1 — Viewing patterns generated by a similar pair of lens arrays

B.2 Theory

The moiré magnifier can perhaps most simply be understood by considering the vernier moiré effect in which the two arrays have slightly different pitches. The pitch, or the period, is defined as the distance between adjacent units in the array. The effect of each lens is to sample the object array and to fill the aperture of the lens with information relating to the object array at the focal point.

If the lens array had exactly the same pitch as the object array and were correctly aligned, all lenses would view the identical regions of their corresponding objects and the field of view would be uniform, as shown in Figure B.2. This corresponds to a "fluffed out" fringe.

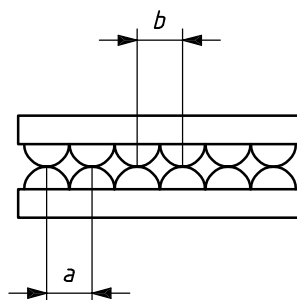

Key

- a* period of the object array
- b* period of the lens array

Figure B.2 — Pair of lens arrays with similar pitch

If two arrays have different pitches as shown in Figure B.3, each lens will view an adjacent area on the object beneath it.

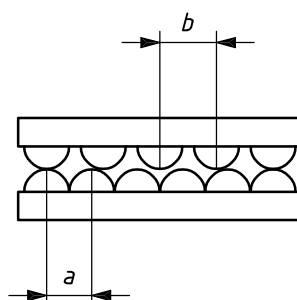

Key

- a* period of the object array
- b* period of the lens array

Figure B.3 — Pair of lens arrays with different pitch

As one scans across the lens array a sampled picture of the object is built up. This continues until the lens array is out of phase by one period, corresponding to one moiré fringe, when the process starts again.

This occurs at the n th lens where

$$na = (n + 1) b \quad (\text{B.1})$$

where

n is the lens number;

a is the period of the object array;

b is the period of the lens array;

and where $a \approx b$

$$n = \frac{b}{a - b} = \frac{a}{\Delta} \quad (\text{B.2})$$

where Δ is the difference in period and

$$\Delta = (a - b)$$

The size of the enlarged image is then

$$\frac{a^2}{\Delta} \quad (\text{B.3})$$

and the magnification is $\frac{a}{\Delta}$

From this it is clear that the magnification tends to infinity as the difference in pitch tends to zero. "Infinite" magnification corresponds to a fluffed out moiré fringe.

The magnified image is built up by sampling the object at a number of discrete points, equal to the number of lenses in the moiré fringe. The whole object may, however, be scanned by translating the lens array. In this case the resolution is determined by the numerical aperture and the quality of the microlenses.

B.3 Equipment

A standard lens array with a similar pitch to the array under test, collimated illumination, translation stages, a viewing system and a rotation stage are required.

B.4 Procedure

For a quick assessment, hold the standard lens array in close contact and view against a light background. Adjust the separation of the arrays with thin shim spacers until a magnified image of the test array is seen. Adjust laterally and rotate one array relative to the other to generate patterns of moiré bands. The two arrays have similar geometry if it is possible to "fluff-out" the bands to achieve uniform intensity. For a more precise assessment mount the lens arrays on translation stages and carefully align and photograph the moiré patterns.

Bibliography

- [1] ISO 3274, *Geometrical Product Specifications (GPS) — Surface texture: Profile method — Nominal characteristics of contact (stylus) instruments*
- [2] ISO 4287:1997, *Geometrical Product Specifications (GPS) — Surface texture: Profile method — Terms, definitions and surface texture parameters*
- [3] ISO 4288, *Geometrical Product Specifications (GPS) — Surface texture: Profile method — Rules and procedures for the assessment of surface texture*
- [4] ISO 5436-1, *Geometrical Product Specifications (GPS) — Surface texture: Profile method; Measurement standards — Part 1: Material measures*
- [5] ISO 14880-2, *Optics and photonics — Microlens arrays — Part 2: Test methods for wavefront aberrations*
- [6] ISO/TR 14999-1, *Optics and photonics — Interferometric measurement of optical elements and optical systems — Part 1: Terms, definitions and fundamental relationships*
- [7] FLACK, D.R. *Measurement Good Practice Guide No 40 — Callipers and Micrometers*. NPL Teddington 2001
- [8] LEACH, R.K. *Measurement Good Practice Guide No 37 — The measurement of Surface Texture using Stylus Instruments*. NPL Teddington 2001
- [9] *Guide to the expression of uncertainty in measurement (GUM)*, BIPM, IEC, IFCC, ISO, IUPAC, IUPAP, OIML, 1993, corrected and reprinted in 1995
- [10] HUTLEY, M.C., DALY, D. STEVENS, R.F. *The testing of microlens arrays, Proc. IOP/NPL meeting on Microlens Arrays*, held at NPL Teddington, May 1991, IOPP Bristol, pp. 67-81
- [11] DALY, D., HUTLEY, M.C. *Microlens measurement at NPL, Proc IOP/NPL meeting Microlens Arrays*, held at NPL Teddington, May 1993, pp. 50–54
- [12] SCHWIDER, J., FALKENSTORFER, O. *Twyman-Green interferometer for testing microspheres, Proc IOP/NPL meeting Microlens Arrays*, held at NPL Teddington, May 1995, pp. 60-64
- [13] STEVENS, R.F. Optical inspection of periodic structures using lens arrays and moiré magnification. *The Imaging Science Journal*, **47**, 1999, pp. 173–179
- [14] TIZIANI, H.J., HAIST, T., REUTER, S. *Optical inspection and characterization of microoptics using confocal microscopy, Optics and Lasers in Engineering*, **36**, 2001, pp. 403-415

Bureau of Indian Standards

BIS is a statutory institution established under the *Bureau of Indian Standards Act, 2016* to promote harmonious development of the activities of standardization, marking and quality certification of goods and attending to connected matters in the country.

Copyright

BIS has the copyright of all its publications. No part of these publications may be reproduced in any form without the prior permission in writing of BIS. This does not preclude the free use, in the course of implementing the standard, of necessary details, such as symbols and sizes, type or grade designations. Enquiries relating to copyright be addressed to the Head (Publication & Sales), BIS.

Review of Indian Standards

Amendments are issued to standards as the need arises on the basis of comments. Standards are also reviewed periodically; a standard along with amendments is reaffirmed when such review indicates that no changes are needed; if the review indicates that changes are needed, it is taken up for revision. Users of Indian Standards should ascertain that they are in possession of the latest amendments or edition by referring to the website-www.bis.gov.in or www.standardsbis.in.

This Indian Standard has been developed from Doc No.: PGD 39 (24222).

Amendments Issued Since Publication

Amend No.	Date of Issue	Text Affected

BUREAU OF INDIAN STANDARDS

Headquarters:

Manak Bhavan, 9 Bahadur Shah Zafar Marg, New Delhi 110002

Telephones: 2323 0131, 2323 3375, 2323 9402

Website: www.bis.gov.in

Regional Offices:

	Telephones
Central : 601/A, Konnectus Tower -1, 6 th Floor, DMRC Building, Bhavbhuti Marg, New Delhi 110002	{ 2323 7617
Eastern : 8 th Floor, Plot No 7/7 & 7/8, CP Block, Sector V, Salt Lake, Kolkata, West Bengal 700091	{ 2367 0012 2320 9474
Northern : Plot No. 4-A, Sector 27-B, Madhya Marg, Chandigarh 160019	{ 265 9930
Southern : C.I.T. Campus, IV Cross Road, Taramani, Chennai 600113	{ 2254 1442 2254 1216
Western : 5 th Floor/MTNL CETTM, Technology Street, Hiranandani Gardens, Powai Mumbai 400076	{ 25700030 25702715

Branches : AHMEDABAD, BENGALURU, BHOPAL, BHUBANESHWAR, CHANDIGARH, CHENNAI, COIMBATORE, DEHRADUN, DELHI, FARIDABAD, GHAZIABAD, GUWAHATI, HARYANA (CHANDIGARH), HUBLI, HYDERABAD, JAIPUR, JAMMU, JAMSHEDPUR, KOCHI, KOLKATA, LUCKNOW, MADURAI, MUMBAI, NAGPUR, NOIDA, PARWANOO, PATNA, PUNE, RAIPUR, RAJKOT, SURAT, VIJAYAWADA.