खाद्य और पेय पदार्थों के लिए तीन खंड से
बने गोल खुले शीर्ष वाले धातु के कैन के
लिए लैकर और सजावटी परिष्कर —
विशिष्टि

**Lacquers and Decorative Finishes
for Three Piece Round Open Top
Metal Cans for Foods and
Beverages — Specification**

ICS 52.120; 87.040

© BIS 2024



भारतीय मानक ब्यूरो
BUREAU OF INDIAN STANDARDS
मानक भवन, 9 बहादुर शाह ज़फर मार्ग, नई दिल्ली - 110002
MANAK BHAVAN, 9 BAHADUR SHAH ZAFAR MARG
NEW DELHI - 110002
www.bis.gov.in www.standardsbis.in

FOREWORD

This Indian Standard was adopted by the Bureau of Indian Standards, after the draft finalized by the Metal Containers Sectional Committee had been approved by the Production and General Engineering Division Council.

Lacquers for interior of food cans are intended to provide a barrier coat to prevent interaction between the can and the contents which might result in deterioration of the product or in reduced can performance. The internal finishes are usually clear but may be pigmented. The finishes for exterior of food cans are intended either to reduce the risk of external corrosion or for the purpose of decoration. These finishes may be lacquers or complete lithographic decorative finishes.

The composition of the Committee responsible for formulation of this standard is given in Annex C.

For the purpose of deciding whether a particular requirement of this standard is complied with, the final value, observed or calculated expressing the result of a test or analysis, shall be rounded off in accordance with IS 2 : 2022 'Rules for rounding off numerical values (*second revision*)'. The number of significant places retained in the rounded off value should be the same as that of the specified value in this standard.

Indian Standard

LACQUERS AND DECORATIVE FINISHES FOR THREE PIECE ROUND OPEN TOP METAL CANS FOR FOODS AND BEVERAGES — SPECIFICATION

1 SCOPE

This standard describes the different types of lacquer in contact with food products, their requirements and methods of sampling and tests for internal lacquers, and also for the exterior lacquers towards protection and decoration of three piece round open top metal cans. This draft standard pertains to cans made of electrolytic tinplate (ETP) as per IS 1993 or electrolytic chromium/chromium-coated steel (ECCS) as per IS 12591.

2 REFERENCES

The standards listed in Annex A contain provisions which, through reference in this text, constitute provisions of this standard. At the time of publication, the editions indicated were valid. All standards are subject to revision, and parties to agreements based on this standard are encouraged to investigate the possibility of applying the most recent editions of these standards.

3 TERMINOLOGY

For the purpose of this standard, the definitions given in IS 1303, IS 11104 and the following shall apply.

3.1 Infant — A child under the age of 12 months.

3.2 Specific Migration Limit (SML) — The specific migration is the amount of a specific compound that has migrated from the food-contact material into the food or simulants.

3.3 Technical Data Sheet (TDS) — A document designed to provide information on a specific lacquer product. The type of information typically includes product uses, features, service properties, application properties, application instructions, packaging information and information on storage and handling.

3.4 Young Child — A child aged between 1 year and 3 years.

4 CLASSIFICATION

4.1 There shall be three categories of material as follows:

- a) Category A : Internal food can lacquers
- b) Category B : External food can lacquers
- c) Category C : Decorative finishes (base coat + ink + varnish)

4.2 Category A shall consist of the following classes:

- a) Class I : Thermally processed food can lacquers
- b) Class II : Non-thermally processed food can lacquers

4.3 Class I lacquers, depending on the end use and the type of foods shall further be classified into following sub-classes (*see* Table 1):

- a) Sub-Class 1: Acid resistant lacquer
- b) Sub-Class 2: Sulphur resistant lacquer

5 REQUIREMENTS**5.1 Composition**

The food contact lacquer and non-food contact coatings are mixture of resins, cross linkers, solvents, additives and other starting substances and form a polymeric coating. The resin can be either natural, synthetic or a mixture of both.

5.1.1 The following types of resin can be used for the manufacture of the internal coating:

- a) Epoxy phenolic,
- b) Epoxy amino,
- c) Epoxy anhydride,
- d) Organosol, and
- e) Polyester phenolic.

Table 1 Classification of Internal Food Lacquers
(Clause 4.3)

SI No.	Classification		Types of Food	Food Products
(1)	(2)		(3)	(4)
i)	Thermally Processed Food	Sub-Class 1	High to low acid foods	Citrus fruits and pulps, fruit juices, fruit pulp, fruit puree, pickles, gherkins, tomato ketchup, butter, cheese, curd, mayonnaise, marmalade, jalapenos, tomato puree, red paprika in vinegar, vegetables, baby corn, sweet corn, Ready-to-eat (RTE), Indian sweet meats, etc.
		Sub-Class 2	High Sulphur containing foods	Meat, fish, sea foods, mushrooms, green peas, etc.
ii)	Non-Thermally Processed Food		Non-acidic food with high fat and high moisture content, edible oil, and dry foods	Vegetable oil, ghee, bakery products, confectioneries, spice powder, snacks and savouries, tea/coffee powder, fried and roasted nuts, condensed milk, protein powder, etc.

5.1.2 The following types of resin can be used for the manufacture of the external coating:

- Vinyl,
- Acrylic,
- Polyester,
- Epoxy phenolic,
- Epoxy amino, and
- Alkyd/modified alkyd.

5.1.3 The following types of resin can be used for the manufacture of the side stripe coating:

- Epoxy phenolic,
- Epoxy amino,
- Epoxy powder,
- Polyester powder, and
- Polyester liquid.

5.2 Appearance

5.2.1 The appearance of the food contact surface lacquer are usually as follows:

- Clear or transparent,
- Gold lacquer,
- White lacquer, and
- Aluminised lacquer.

5.2.2 The appearance of the non-food contact surface external coatings are usually as follows:

- Clear or transparent size coatings,
- Gold coatings,

- Clear or transparent varnish coatings, and
- Pigmented colour coatings.

5.2.3 The appearance of side strip lacquer is either clear, gold, white or grey colour in nature.

5.3 Application Process and Parameter

The organic food lacquer is applied by roller coating. Hence, the viscosity of the lacquer should comply with the application process. The coating should be applied without any visible application defects like craters, pinholes, fish eyes, wicket marks, etc. The deposition of the lacquer is mostly measured in terms of gram per square meter (gsm) or mg per square inch (msi) [1 gsm = 1.55 msi]. Application film weights are dependent on formulation, technology and should be followed as per the supplier TDS.

5.4 Liquid Properties and Performance Requirements

5.4.1 Internal Lacquer

The internal lacquer shall conform to the following requirements:

- Solid content* — It shall be as given in Table 2 when tested in accordance with **B-1**.
- Viscosity* — It shall be as given in Table 2

- when tested in accordance with **B-2**.
- c) *Specific gravity* — It shall be as given in Table 2 when tested in accordance with **B-3**.
 - d) *Dry film weight* — It depends on the type of lacquer and shall conform the value specified in TDS when tested in accordance with **B-4**.
 - e) *Solvent resistance test* — The lacquer shall pass the test as specified in **B-5**.
 - f) *Chemical resistance tests* — The lacquer shall pass the test as specified in **B-6**.
 - g) *Process resistance test (retort)* — The lacquer shall pass the test as specified in **B-7**.
 - h) *Cross-cut adhesion* — The lacquer shall pass the test as specified in **B-8**.
 - j) *Scratch hardness* — The minimum load at which the needle penetrates the coating shall be as agreed between manufacturer and purchaser when the scratch hardness test is performed in accordance with IS 101 (Part 5/Sec 2).
 - k) *Product compatibility test* — The lacquer shall pass the test as specified in **B-9**.
 - m) *Porosity test (lacquer continuity test)* — The lacquer shall pass the test as specified in **B-10**.
 - n) *Optical requirement* — The lacquer should pass the test as specified in **B-11**.

5.4.2 Side Stripe Lacquers

The exposure in the side seam after welding process needs to be covered by a suitable protective lacquer. General paint application techniques have been

devised for applying side stripe protection to the weld and the area immediately adjacent to it. This can be applied either inside the cylinder (internal side stripe), on the outside of welded cylinder (external side stripe) or both. Liquid and powder side stripe lacquers can be used, depending on the level of protection and appearance. Liquid side stripes can be applied both internally and externally whereas powder side stripes are generally applied at the internals of the cans. Liquid side stripes can be applied by brush or by spraying, however the powder side stripes are always applied by electrostatic spraying.

The side stripe shall be tested for the following physical properties:

- a) *Solid content* — It shall be as given in Table 3 when tested in accordance with **B-1**.
- b) *Viscosity* — It shall be as given in Table 3 when tested in accordance with **B-2**.
- c) *Specific gravity* — It shall be as given in Table 3 when tested in accordance with **B-3**.

5.4.2.1 Liquid side stripe

The liquid side stripes shall be further tested for following requirements:

- a) *Film weight* — throughout the length of the stripe application shall conform to the value specified in TDS when tested in accordance with **B-4**.
- b) *Solvent resistance test* — The lacquer shall pass the test as specified in **B-5**.
- c) *Process resistance test (retort)* — The lacquer shall pass the test as specified in **B-7**.
- d) *Cross-cut adhesion* — The lacquer shall pass the test as specified in **B-8**.

Table 2 Liquid Properties of Internal Lacquer

(Clause 5.4.1)

Sl No.	Product Category	Solid Content, <i>Min</i> (in percent)	<i>Min</i> Viscosity at 30 °C using B4 Cup (in seconds)	Specific Gravity, <i>Min</i>
(1)	(2)	(3)	(4)	(5)
i)	Epoxy phenolic	30	70	0.90
ii)	Epoxy amino	30	70	0.90
iii)	Epoxy anhydride	45	100	1.18
iv)	Polyester phenolics	38	100	0.97
v)	Organosol	45	70	1.20

Table 3 Liquid Properties of Side Stripe Lacquer

(Clause 5.4.2)

SI No.	Product Category	Solid Content, <i>Min</i> (in percent)	<i>Min</i> Viscosity at 30 °C using B4 Cup (in seconds)	Specific Gravity, <i>Min</i>
(1)	(2)	(3)	(4)	(5)
i)	Epoxy phenolic	22	20	0.92
ii)	Epoxy amino	10	10	0.86
iii)	Epoxy powder	—	—	1.30
iv)	Polyester powder	—	—	1.35
v)	Polyester liquid	30	15	0.92

5.4.2.2 Powder side stripe

The powder side stripes shall be further tested for following requirements:

- Film thickness* — Throughout the length of the stripe application shall conform the value specified in TDS when tested in accordance with 6 of IS 101 (Part 3/Sec 2).
- Process resistance test (retort)* — The lacquer shall pass the test as specified in **B-7**.
- Porosity test (lacquer continuity test)* — The lacquer shall pass the test as specified in **B-10**.
- Cross-cut adhesion* — The lacquer shall pass the test as specified in **B-12.1**.
- Fracture test* — The lacquer shall pass the test as specified in **B-12.2**.

5.4.3 Decorative Finishes

5.4.3.1 The external finishes are applied mainly for protection and aesthetics; however, the main purpose can be divided as follows:

- Protection* — The cans need to be protected from the thermal process conditions, environmental influence such as corrosive agents that are present during weathering. The external coating thereby confers durability on the cans.
- Decoration* — External coatings provide product information in a variety of ways including text, diagrams and numerical values/bar codes, etc.
- Brand information* — External images are

also used to provide brand information such as brand logo, trade names, manufacturer information, distributor information, etc.

- Printability* — If printing is to be applied, the inks/coatings need to be printable, adhere to the surface of the can, and be compatible with the can.

5.4.3.2 Testing for the decorative finishes

The external system shall be tested for the following:

- Solid content* — It shall be as given in Table 4 when tested in accordance with **B-1**.
- Viscosity* — It shall be as given in Table 4 when tested in accordance with **B-2**.
- Specific gravity* — It shall be as given in Table 4 when tested in accordance with **B-3**.
- Bend test* — The lacquer shall pass the bend test as specified in IS 101 (Part 5/Sec 2).
- Scratch hardness* — The minimum load at which the needle penetrates the coating shall be as agreed between manufacturer and purchaser when the scratch hardness test is performed in accordance with IS 101 (Part 5/Sec 2).
- Process resistance test (retort)* — The lacquer shall pass the test as specified in **B-7**.
- Cross-cut adhesion* — The lacquer shall pass the test as specified in **B-8**.
- Ink jet testing* — The lacquer shall pass the test as specified in **B-13**.
- Blocking/stack test* — The lacquer shall pass the test as specified in **B-14**.

Table 4 Liquid Properties of Decorative Finishes

(Clause 5.4.3.2)

Sl No.	Product Category	Solid Content, <i>Min</i> (in percent)	<i>Min</i> Viscosity at 30 °C using B4 Cup (in seconds)	Specific Gravity, <i>Min</i>
(1)	(2)	(3)	(4)	(5)
i)	Vinyls	14	30	0.90
ii)	Pigmented acrylic	50	120	1.28
iii)	Acrylic varnish	40	70	0.93
iv)	Pigmented polyesters	50	90	1.35
v)	Polyester varnish	38	45	0.95
vi)	Pigmented alkyd/modified alkyd	50	120	1.20
vii)	Alkyd/modified alkyd varnish	42	50	0.90
viii)	Epoxy phenolic	30	70	0.90
ix)	Epoxy amino	30	70	0.90

5.5 Migration

Polymeric based coating material while coming into contact with food product, there is a tendency of leaching or migration of substances like monomers, oligomers, additives, pigments, etc from polymeric material to food product which might cause a carcinogenic effect. Therefore, the residual migrants are estimated as overall migration and the individual restricted heavy metal elements which might cause health hazards are analyzed as specific migration.

5.5.1 Overall Migration Limit (OML)

The acceptable overall migration limit shall be $10 \text{ mg/dm}^2 \pm 1 \text{ mg/dm}^2$ or 60 mg/kg when tested in accordance with IS 9845.

5.5.2 Specific Migration Limit (SML)

5.5.2.1 The specific migration shall not exceed the maximum limit given in Table 5. The sample for the specific migration test shall be prepared as per IS 9845 wherein the lacquer would be exposed to the simulants. The extracted simulants shall be then detected for elements given in Sl No. (i) to (viii) of Table 5 in accordance with the test method specified in IS 3025 (Part 2) or IS 3025 (Part 65). Di (2-ethylhexyl) phthalate (DEHP) shall be measured as per the method specified in ISO 18856.

5.5.2.2 No migration of Bisphenol A (BPA) shall be permitted from lacquer applied to materials and articles specifically intended to come into contact

with infant formula, follow-on formula, processed cereal-based food, baby food, food for special medical purposes developed to satisfy the nutritional requirements of infants and young children or milk-based drinks and similar products specifically intended for young children.

6 PACKING AND MARKING

6.1 Packing

The material shall be packed as agreed between the purchaser and the supplier.

6.2 Marking

6.2.1 The containers shall be marked with the name of the material, category, class, sub-class and trademark, if any, volume of the material, month and year of manufacture.

6.2.2 BIS Certification Marking

The product(s) conforming to the requirements of this standard may be certified as per the conformity assessment schemes under the provisions of the *Bureau of Indian Standards Act, 2016* and the Rules and Regulations framed thereunder, and the products may be marked with the Standard Mark.

7 SAMPLING

The sampling method shall be as per IS 101 (Part 1/Sec 1).

Table 5 Specific Migration Limit*(Clause 5.5.2.1)*

Sl No.	Substances	Specific Migration Limit (SML) mg/kg
(1)	(2)	(3)
i)	Barium	1
ii)	Cobalt	0.05
iii)	Copper	5
iv)	Iron	48
v)	Lithium	0.6
vi)	Manganese	0.6
vii)	Zinc	25
viii)	Sb	0.04
ix)	Phthalic acid, bis-2-ethyl hexyl ester, DEHP	1.5

ANNEX A

(Clause 2)

LIST OF REFERRED STANDARDS

<i>IS No./Other Standards</i>	<i>Title</i>	<i>IS No./Other Standards</i>	<i>Title</i>
IS 101	Methods of sampling and test for paints, varnishes and related products:	(Part 65) : 2022/ ISO 17294-2 : 2016	Application of inductively coupled plasma mass spectrometry (ICP-MS) — Determination of selected elements including uranium isotopes (<i>first revision</i>)
(Part 1/Sec 1) : 1986	Tests on liquid paints (general and physical), Section 1 Sampling (<i>third revision</i>)	IS 9845 : 1998	Determination of overall migration of constituents of plastics materials and articles intended to come in contact with foodstuffs — Method of analysis (<i>second revision</i>)
(Part 3/Sec 2) : 1989	Tests on paint film formation, Section 2 Film thickness (<i>third revision</i>)	IS 11104 : 2012	Glossary of terms relating to open top sanitary cans (<i>first revision</i>)
(Part 5/Sec 2) : 1988	Mechanical tests, Section 2 Flexibility and adhesion (<i>third revision</i>)	IS 12591 : 2018/ISO 11950 : 2016	Cold-reduced tinmill products — Electrolytic chromium/chromium oxide — Coated steel (<i>second revision</i>)
IS 1303 : 1983	Glossary of terms relating to paints (<i>second revision</i>)	ISO 18856 : 2004	Water quality — Determination of selected phthalates using gas chromatography/mass spectrometry
IS 1993 : 2018/ISO 11949 : 2016	Cold-reduced tinmill products — Electrolytic tinplate (<i>fifth revision</i>)		
IS 3025	Methods of sampling and test (physical and chemical) for water and wastewater:		
(Part 2) : 2019/ ISO 11885 : 2007	Determination of selected elements by inductively coupled plasma optical emission spectrometry (ICP-OES) (<i>first revision</i>)		

ANNEX B

(Clause 5.4)

TESTING AND REQUIREMENTS OF LACQUER COATING**B-1 SOLID CONTENT**

- a) Take a foil with a small clip and weigh it in an analytical balance (with four-digit accuracy). Record it as W_1 .
- b) Tare the weight in the balance.
- c) Take 1 g to 1.5 g sample on the foil. Accurately measure the weight of the sample, P .
- d) Spread the sample evenly in the foil with the help of the clip.
- e) Put the foil containing the sample in the oven and cure it as per the specified temperature and time as mentioned in the technical data sheet.
- f) Weigh the dried sample and record it as W_2 .
- g) Calculate the percent solid content using the formula given below:

$$\left[\frac{W_2 - W_1}{P} \right] \times 100$$

B-2 VISCOSITY**B-2.1 Procedure**

- a) Use flow cup (B4, Ford cup, ISO cup, DIN cup) for measuring the efflux time (flow time in seconds is a measure of the thickness of the material, efflux time will be less for less thick material and will be more for more thick material).
- b) Stir the lacquer thoroughly before measuring the viscosity.
- c) Hold the orifice of the flow cup with a finger and pour the lacquer in the flow cup. Ensure that the cup is fully filled.
- d) Remove the finger from the orifice and immediately start the stopwatch to record the flow.
- e) Stop the stopwatch when there is first break in the flow of the lacquer. The time in seconds will give an indirect indication of the viscosity of the lacquer.

B-3 SPECIFIC GRAVITY**B-3.1 Procedure**

- a) Use a pycnometer (100 cm³) for measuring the specific gravity of the lacquer.
- b) Mix the lacquer thoroughly before measuring the specific gravity.
- c) Weigh the pycnometer along with its lid in an analytical balance (with four-digit accuracy). Record it as W_1 .
- d) Pour the lacquer in the pycnometer and make sure that the pycnometer is fully filled with the lacquer.
- e) Weigh the lacquer filled pycnometer in an analytical balance (with four-digit accuracy). Record it as W_2 .
- f) Calculate specific gravity using the formula given below:

$$\frac{W_2 - W_1}{100}$$

B-4 DRY FILM WEIGHT**B-4.1 Procedure**

- a) Take a specimen sample with a defined area and weigh it in an analytical balance up to two decimal and record it as W_1 .
- b) After that, remove the coating completely by rubbing with any solvent (for example, acetone, ammonia, aniline) without damaging the metal substrate.
- c) Weigh specimen sample again and record it as W_2 .
- d) Calculate the value of dry film weight (*DFW*) from the following formula:

$$DFW = \frac{W_1 - W_2}{Area}$$

B-5 SOLVENT RESISTANCE TEST

This test is carried out to check the degree of curing.

B-5.1 Procedure

- a) Take a specimen sample of lacquered surface.
- b) Take cotton swab soaked with a solvent, for example, acetone, methyl ethyl ketone (MEK), methyl isobutyl ketone (MIBK), etc.
- c) Rub the cotton swab on specimen sample gently in forward and backward motion (1 kg/cm² or equivalent pressure).
- d) The test failure shall be considered on the middle zone of the tested portion.
- e) The specific solvent to be used and then number of double rubs to be achieved shall be agreed upon between manufacturer and user for any given coating system, thickness, and application.

B-5.2 Acceptance Criteria

After performing the test, the lacquer shall not remove from the substrate.

B-6 CHEMICAL RESISTANCE TESTS

The chemical resistance tests are applicable only for processed food application in which retorting is done. These tests as given in **B-6.1**, **B-6.2** and **B-6.3** are carried out to check the compatibility of the lacquer with citric acid, maleic acid and sodium chloride, respectively.

B-6.1 Citric Acid Test**B-6.1.1 Reagent**

Citric Acid	:	2.0 g
Water	:	100 ml

B-6.1.2 Procedure

Boil the citric acid solution. Immerse the specimen lacquered sample in boiling solution for 30 min. Take out the sample after 30 min and examine.

B-6.1.3 Acceptance Criteria

The tested sample shall be considered satisfactory if it conforms to the following requirements:

- a) There shall be no blushing,
- b) There shall be no significant change in color/shade, and

- c) There shall be no peel off of lacquer from substrate.

B-6.2 Maleic Acid Test**B-6.2.1 Reagent**

Maleic acid	:	0.5 gm
Water	:	100 ml

B-6.2.2 Procedure

Boil the maleic acid solution. Immerse the specimen lacquered sample in boiling solution for 30 min. Take out the sample after 30 min and examine.

B-6.2.3 Acceptance Criteria

The tested sample shall be considered satisfactory if it conforms to the following requirements:

- a) There shall be no blushing,
- b) There shall be no significant change in color/shade, and
- c) There shall be no peel off of lacquer from substrate.

B-6.3 Sodium Chloride Test**B-6.3.1 Reagent**

Sodium Chloride	:	2.0 g
Water	:	100 ml

B-6.3.2 Procedure

Boil the sodium chloride solution. Immerse the specimen lacquered sample in boiling solution for 30 min. Take out the sample after 30 min and examine.

B-6.3.3 Acceptance Criteria

The tested sample shall be considered satisfactory if it conforms to the following requirements:

- a) There shall be no blushing,
- b) There shall be no significant change in color/shade, and
- c) There shall be no peel off of lacquer from substrate.

B-7 PROCESS RESISTANCE TEST

This test is done to examine the resistance of lacquer against the sterilization for processed foods, and other features like loss of gloss, sublimation,

blushing, color change and any enhancement of tooling damage. The test is applicable only for processed food application in which retorting is done.

B-7.1 Procedure

The specimen sample shall be retorted at 121 °C for 90 min.

B-7.2 Acceptance Criteria

The tested sample shall be considered satisfactory if it conforms to the following requirements:

- a) There shall be no blushing,
- b) There shall be no significant change in color/shade, and
- c) There shall be no peel off of lacquer from substrate.

B-8 CROSS-CUT ADHESION

This test is carried out to ensure the adhesion of lacquer with substrate.

B-8.1 Procedure

- a) Cross marking of 1 mm × 1 mm size is done on lacquered substrate by making 10 horizontal and 10 vertical scratches (this will become 100 squares of 1 mm × 1 mm). Cross hatch marker is commonly used for this purpose.
- b) Thereafter, apply 1 inch wide cello tape on these squares and press with thumb to ensure that no air is trapped in between tape and specimen sample. Pull the tape suddenly.
- c) The surface shall then be examined and classified as per the table given in **B-8.2**. In order to judge the visibility of the failure in a better way, copper sulphate solution test can be done as described below from **B-8.1(d)** to **B-8.1(f)**.
- d) Prepare copper sulphate solution by mixing 20 parts by mass of copper sulphate with 80 parts by mass of distilled water.
- e) Copper sulphate solution is applied on these squares. Copper sulphate reacts with base material which results in change in colour.
- f) Take out the panel from the lacquered substrate. Dip these panels in copper sulphate solution for 2 min. After two minutes, take out these panels and wash and examine for any damage of the film.

B-8.2 Acceptance Criteria

The material shall be deemed to have passed the test if the classification done as per the table below does not exceed 1 for inside and 2 for outside finishes.

B-9 PRODUCT COMPATIBILITY TEST

B-9.1 Product compatibility test of the lacquer shall be done with the actual food which is intended to be kept in the lacquer coated cans. However, it needs to be ensured that there shall not be any black spots on body and ends of the empty can till the can are used for food contact application. The product in the can should be packed, retorted/pasteurized as the case may be and to be stored at temperature of 38 °C with 90 percent relative humidity for a period of one-third of the anticipated shelf life.

B-9.2 Acceptance Criteria

The tested sample shall be considered satisfactory if it conforms to the following requirements:

- a) There shall be no dissolution or peel off of the lacquer.
- b) It shall comply with specific migration as specified in **5.5.2**.

NOTE — The cans during the test may develop black spots. This is acceptable if it conforms to the migration requirement as per **5.5.2**.

B-10 POROSITY TEST (LACQUER CONTINUITY TEST)

This test is carried out to check the integrity of the film.

B-10.1 Apparatus — enamel rater

B-10.2 Test Media

One percent NaCl or any other solution as per the instrument supplier shall be used as the test media.

B-10.3 Procedure

- a) Select specimen sample(s) to be checked.
- b) Switch on the enamel rating testing instrument.
- c) Fill the solution in the can.
- d) Insert the electrode in filled cans.
- e) Perform the test at 6.3 V for 4 seconds.
- f) Record porosity displayed on screen in mA.

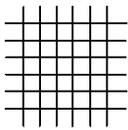
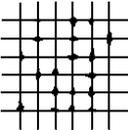
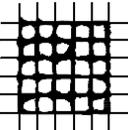
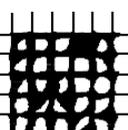
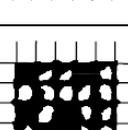
<i>Classification</i>	<i>Description</i>	<i>Appearance of surface of cross-cut area from which flaking has occurred¹</i> <i>(Example for six parallel cuts)</i>
0	The edges of the cuts are completely smooth; none of the squares of the lattice is detached.	
1	The edges of the cuts are completely smooth; none of the squares of the lattice is detached.	
2	The coating has flaked along the edges and/or at the intersections of the cuts. A cross-cut area greater than 5 percent, but not greater than 15 percent, is affected.	
3	The coating has flaked along the edges of the cuts partly or wholly in large ribbons, and/or it has flaked partly or wholly on different parts of the squares. A cross-cut area greater than 15 percent, but not greater than 35 percent, is affected.	
4	The coating has flaked along the edges of the cuts in large ribbons and/or some squares have detached partly or wholly. A cross-cut area greater than 35 percent, but not greater than 65 percent, is affected.	
5	Any degree of flaking that cannot even be classified by classification 4.	—

¹⁾ The figures are examples for a cross-cut within each step of the classification. The percentages stated are based on the visual impression given by the pictures and the same percentages will not necessarily be reproduced with digital imaging.

B-10.4 Acceptance Criteria

The acceptable values of the porosity in mA shall be as given in the table below:

<i>Trade Size</i>	<i>Can Diameter (in mm)</i>	<i>Can Height (in mm)</i>	<i>Inside Lacquered Cans (Double Coat Lacquer)</i>		<i>Inside Lacquered Cans (Single Coat Lacquer)</i>	
			<i>Max Reading in One Can (in mA)</i>	<i>Average Reading of Cans (in mA)</i>	<i>Max Reading in One Can (in mA)</i>	<i>Average Reading of Cans (in mA)</i>
202	52	104	25	15	100	60
211	65	104	30	20	120	80
300	73	116	35	25	140	100
401	99	119	40	30	160	120
603	153.35	177	60	45	240	180

B-11 OPTICAL REQUIREMENT

This is an optional test and may be performed as per the agreement between and manufacturer and purchaser. Compare the colour of the lacquer with the shade of master sample/approved sample. If shade of both approved sample and batch sample is same, then it shall be considered fit for use. If shade of batch is different from the approved sample than it shall be considered unfit for use.

B-12 POWDER FILM ADHESION

B-12.1 Cross Cut Test

B-12.1.1 Procedure

- a) Cut the powder film cross-shaped with two cuts by using a sharp knife. The angle of the cross shall be 45° to 60° (see Fig. 1A).

The cross cut can be applied over the weld (A)

or to the powder-film only (B). The result may differ depending on Method A or B (see Fig. 1B).

- c) Try to peel-off the powder film from the centre of the cross with the knifepoint (see Fig. 1C).

B-12.1.2 Acceptance Criteria

- a) After the test, the sample shall be considered acceptable if it can be graded as per the below mentioned table.

If the peel-off is more than 10 mm for untreated film, it shall not be acceptable. If the powder film peels off together with the basecoat, higher values (that is, more than 10 mm) are acceptable. After water-sterilization, a peel-off of up to 15 mm is acceptable.

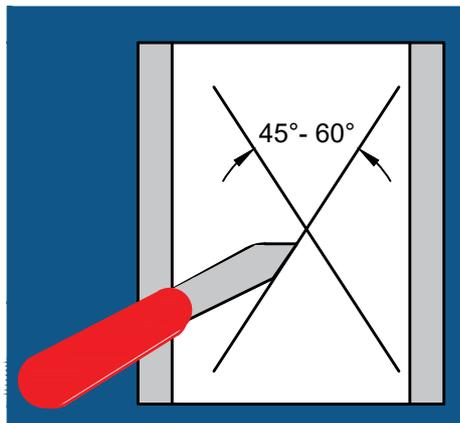

1A

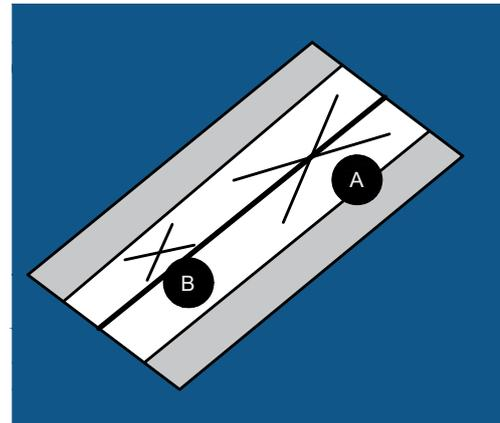

1B

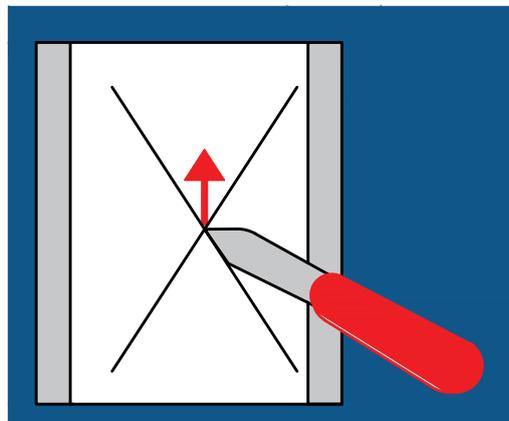

1C

FIG.1 CROSS CUT TEST

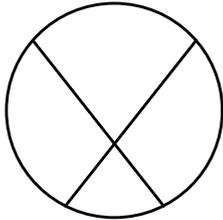
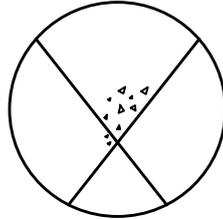
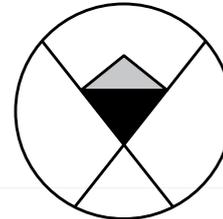
<i>Grade</i>	<i>Description</i>	<i>Appearance of Surface</i>
Very Good	Film Cannot be peeled-off with the knife. Also, not possible to cut out little pieces of the film.	
Good	Small pieces can be removed with the knife.	
Average	Possible to loosen up and peel-off the film. The peeled-off teiangle should not exceed 10 mm for untreated films.	

B-12.2 Fracture Test

B-12.2.1 Procedure

- Cut the plate wedge-shaped till the edge of the seam-stripe. Remove the piece (see Fig. 2A).
- Bend the upper part towards the seam protection stripe (see Fig. 2B).
- Bend the upper part back and forth, till the plate brakes. The two pieces are now held by the powder-film only (see Fig. 2C).
- Fix the lower part with one hand on the table. With the other hand, pull off the upper part from the lower part in an angle of approximately 60° (towards to the seam) (see Fig. 2D).

B-12.2.2 Rating

- Measure the length of the peeled-off film on the lower part (see Fig. 2E).
- Specify the result of the maximum peel in mm.

B-12.2.3 Acceptance Criteria

- The maximum peel-off shall not exceed 12 mm.

- After sterilization with water, up to 20 mm is acceptable.
- In case that the powder-film peels off together with the basecoat, higher values are acceptable (inter-coat adhesion is higher than adhesion of the basecoat to the plate).

B-13 INK JET TESTING

B-13.1 Procedure

- Select specimen sample to check its suitability for ink jet printing and pass through the ink jet printing machine in order to get it printed at couple of places.
- After 4 s to 5 s, try to wipe off ink jet printing manually.
- Thereafter, apply any suitable cello tape on untouched ink jet printing area. Pull the tape manually.

B-13.2 Acceptance Criteria

Ink jet printing shall be considered acceptable if it is intact even after both the tests described in **B-13.1(b)** and **B-13.1(c)**.

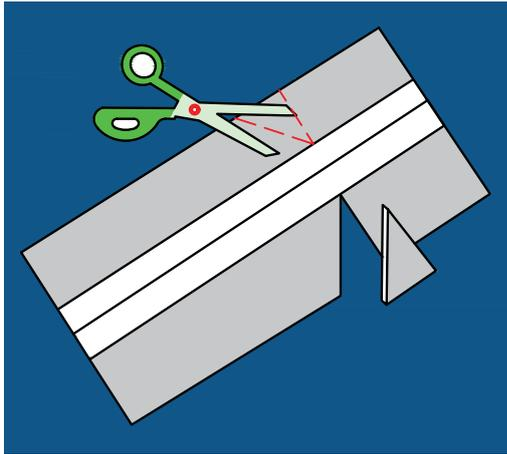

2A

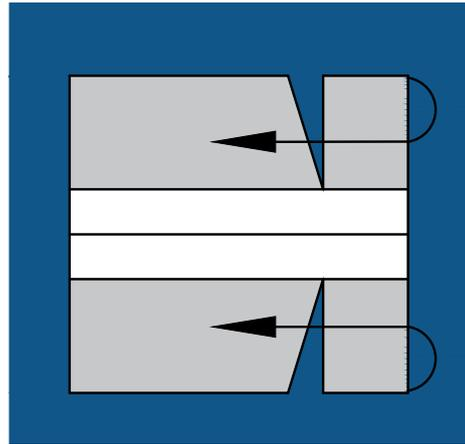

2B

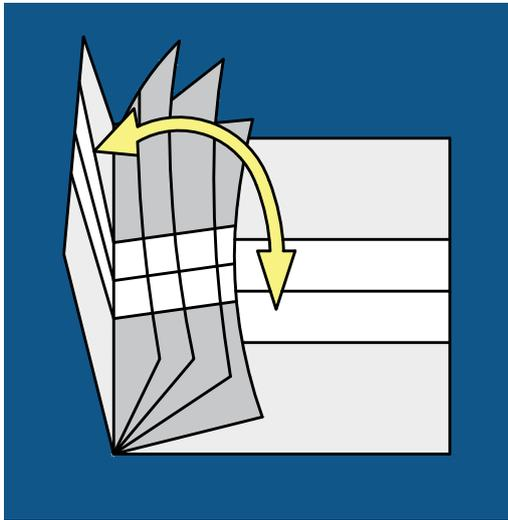

2C

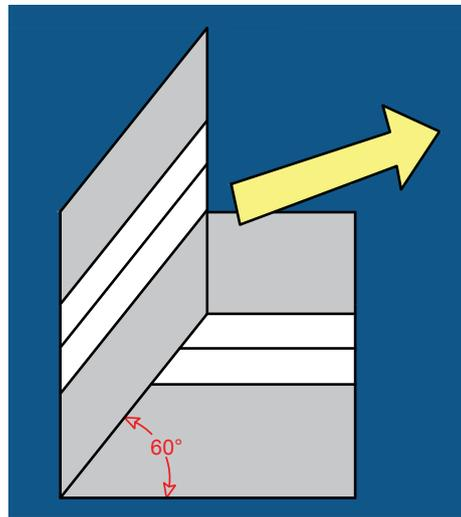

2D

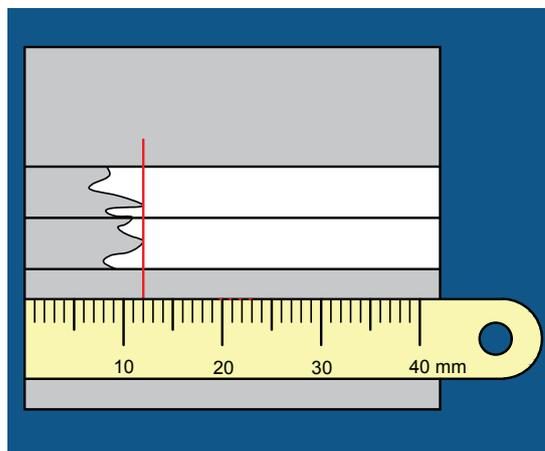

2E

FIG. 2 FRACTURE TEST

B-14 BLOCKING/STACK TEST

B-14.1 Procedure

Apply the coating to a tinplate and bake in an oven at the recommended conditions. After cooling at room temperature, stamp at least 10 to 15 small panels from the sheet. Pile the small panel one on top of the other and apply 2 kg to 3 kg mass over it. Keep the whole set up at 50 °C for a period of 24 h. After test is done, separate the panels by hand and

assess the tack as follows:

- a) Grade 0 = No tack,
- b) Grade 1 = Slight tack,
- c) Grade 2 = Moderate tack, and
- d) Grade 3 = Severe tack.

B-14.2 Acceptance Criteria

The material shall be deemed to have passed the test if grading does not exceed 1.

ANNEX C

(Foreword)

COMMITTEE COMPOSITION

Metal Containers Sectional Committee, PGD 38

<i>Organization</i>	<i>Representative(s)</i>
In Personal Capacity (<i>Flat No. P04, IVY Tower, Nahar Amrit Shakti Chandivali, Powai, Mumbai - 400072</i>)	DR N. C. SAHA (Chairperson)
Ace Cans Manufacturing Company, Mumbai	SHRI KANAK RAJ PARMAR SHRI DINESH PARMAR (<i>Alternate</i>)
Akzo Nobel India Ltd, Gurugram	SHRI MANOJ KUMAR SHARMA SHRI SWAPAN KUMAR BHANDARI (<i>Alternate</i>)
Asian Paints Ltd, Mumbai	SHRI NAVNINDER SINGH MS SHWETA TIWARI (<i>Alternate</i>)
Ball Beverage Packaging (India) Pvt Ltd, Bengaluru	SHRI GANESH NETHA
Balmer Lawrie and Company Ltd, Mumbai	SHRI R. S. PATEL SHRI AMIT MITRA (<i>Alternate</i>)
Balmer Lawrie-Van Leer Ltd, Mumbai	SHRI TUSHAR SHIRWALKAR
Blossom Industries Ltd, Daman	SHRI RAJ KUMAR SHARMA
Canpack India Pvt Ltd, Aurangabad	SHRI SWAPNIL KHESE SHRI AKSHAY SUDAME (<i>Alternate I</i>) SHRI ANOOP KAPADIA (<i>Alternate II</i>)
Caps and Containers, Mumbai	SHRI O. P. AGARWAL MS MANISHA AGARWAL (<i>Alternate</i>)
Cargill India Pvt Ltd, Gurugram	SHRI SEKHAR PAL MS NEHA PARASHAR (<i>Alternate</i>)
Central Insecticide Laboratory, Faridabad	DR J. P. SINGH DR BRIJESH TRIPATHI (<i>Alternate</i>)
Chemco Plastic Industries Pvt Ltd, Mumbai	SHRI GAURAV SARAOGI MS RUPANDE SAMPAT (<i>Alternate</i>)
Coca-Cola India Pvt Ltd, Gurugram	SHRI VIRENDRA LANDGE MS NISHTHA CHAUHAN (<i>Alternate</i>)
Dharampal Satyapal Group, Noida	SHRI SANJAY GUPTA
Directorate General of Quality Assurance, CQA (GS), Kanpur	SHRI M. SATYANARAYANA SHRI BANMALI BEHRA (<i>Alternate</i>)
Hindustan Petroleum Corporation Ltd, Mumbai	SHRI RAVI KUMAR SHRI SUNIL SHANKAR PATIL (<i>Alternate</i>)
Hindustan Tin Works Ltd, New Delhi	SHRI GAJENDRA SINGH SHRI R. K. TYAGI (<i>Alternate</i>)

<i>Organization</i>	<i>Representative(s)</i>
Indian Institute of Packaging, New Delhi	PROF (DR) TANVEER ALAM SHRI MADHAB CHAKRABORTY (<i>Alternate</i>)
Indian Oil Corporation Ltd, Mumbai	SHRI S. MARIMUTHU SHRI S. SHRIDHAR (<i>Alternate I</i>) MS RANI DIXIT (<i>Alternate II</i>)
JSW Steel Coated Products Ltd, Mumbai	SHRI ABHIJIT CHIVANE SHRI CHANCHAL KUMAR KARMAKAR (<i>Alternate I</i>) SHRI AWADHESH MISHRA (<i>Alternate II</i>)
Kaira Can Company Ltd, Mumbai	SHRI K. M. SHENOY SHRI SURESH PANCHAL (<i>Alternate</i>)
Ministry of Consumer Affairs, Food and Public Distribution, New Delhi	SHRI B. N. DIXIT
Nestle India Ltd, Gurugram	SHRI BISWAJIT BASU SHRI BARUN BANERJEE (<i>Alternate</i>)
PPG Asian Paints Pvt Ltd, Mumbai	SHRI SANJAY GHEMAD SHRI ASHWIN PAI (<i>Alternate</i>)
Recon Machine Tools Pvt Ltd, Mumbai	SHRI P. A. PAI
Shetron Ltd, Bengaluru	SHRI KARTIK NAYAK SHRI NITHIN KUMAR SHETTY (<i>Alternate</i>)
The Tinsplate Company of India Ltd, Jamshedpur	DR SOURAJYOTI DEY SHRI BABLU KUMAR SINGH (<i>Alternate I</i>) SHRI SUBRATA SADHU (<i>Alternate II</i>)
Valspar (India) Coatings Corporation Pvt Ltd, Bengaluru	SHRI RAJAT BHATTACHARJEE SHRI SANJAY TYAGI (<i>Alternate</i>)
BIS Directorate General	SHRI R. R. SINGH, SCIENTIST 'F'/SENIOR DIRECTOR AND HEAD (PRODUCTION AND GENERAL ENGINEERING) [REPRESENTING DIRECTOR GENERAL (<i>Ex-officio</i>)]

Member Secretary

SHRI KRISHNA SUDHEENDRAN
SCIENTIST 'C'/DEPUTY DIRECTOR
(PRODUCTION AND GENERAL ENGINEERING), BIS

Panel for Open Top Cans for Foods and Beverages, PGD 38/P1

<i>Organization</i>	<i>Representative</i>
Shetron Limited, Bengaluru	SHRI KARTIK NAYAK (<i>Convener</i>)
Hindustan Tin Works Limited, New Delhi	SHRI R. K. TYAGI
Kaira Can Company Limited, Mumbai	SHRI K. M. SHENOY
Nestle India Limited, Gurugram	SHRI BISWAJIT BASU
The Tinsplate Company of India Limited, Jamshedpur	SHRI AMARNATH PRASAD
Valspar (India) Coatings Corporation Private Limited, Bengaluru	SHRI RAJAT BHATTACHARJEE

Bureau of Indian Standards

BIS is a statutory institution established under the *Bureau of Indian Standards Act, 2016* to promote harmonious development of the activities of standardization, marking and quality certification of goods and attending to connected matters in the country.

Copyright

BIS has the copyright of all its publications. No part of these publications may be reproduced in any form without the prior permission in writing of BIS. This does not preclude the free use, in the course of implementing the standard, of necessary details, such as symbols and sizes, type or grade designations. Enquiries relating to copyright be addressed to the Head (Publication & Sales), BIS.

Review of Indian Standards

Amendments are issued to standards as the need arises on the basis of comments. Standards are also reviewed periodically; a standard along with amendments is reaffirmed when such review indicates that no changes are needed; if the review indicates that changes are needed, it is taken up for revision. Users of Indian Standards should ascertain that they are in possession of the latest amendments or edition by referring to the website- www.bis.gov.in or www.standardsbis.in.

This Indian Standard has been developed from Doc No.: PGD 38 (19359).

Amendments Issued Since Publication

Amend No.	Date of Issue	Text Affected

BUREAU OF INDIAN STANDARDS

Headquarters:

Manak Bhavan, 9 Bahadur Shah Zafar Marg, New Delhi 110002
Telephones: 2323 0131, 2323 3375, 2323 9402

Website: www.bis.gov.in

Regional Offices:

	Telephones
Central : 601/A, Konnectus Tower -1, 6 th Floor, DMRC Building, Bhavbhuti Marg, New Delhi 110002	{ 2323 7617
Eastern : 8 th Floor, Plot No 7/7 & 7/8, CP Block, Sector V, Salt Lake, Kolkata, West Bengal 700091	{ 2367 0012 2320 9474
Northern : Plot No. 4-A, Sector 27-B, Madhya Marg, Chandigarh 160019	{ 265 9930
Southern : C.I.T. Campus, IV Cross Road, Taramani, Chennai 600113	{ 2254 1442 2254 1216
Western : Plot No. E-9, Road No.-8, MIDC, Andheri (East), Mumbai 400093	{ 2821 8093

Branches : AHMEDABAD. BENGALURU. BHOPAL. BHUBANESHWAR. CHANDIGARH. CHENNAI. COIMBATORE. DEHRADUN. DELHI. FARIDABAD. GHAZIABAD. GUWAHATI. HIMACHAL PRADESH. HUBLI. HYDERABAD. JAIPUR. JAMMU & KASHMIR. JAMSHEDPUR. KOCHI. KOLKATA. LUCKNOW. MADURAI. MUMBAI. NAGPUR. NOIDA. PANIPAT. PATNA. PUNE. RAIPUR. RAJKOT. SURAT. VISAKHAPATNAM.