

उत्पाद ग्रेड ए और बी के लिए षट्कोणीय  
शीर्ष वाले काबले, पेंच और ढ़िबरियाँ  
भाग 4 षट्कोणीय पतली ढ़िबरियाँ  
(साइज़ रेंज एम 1.6 से एम 64 तक)  
(पाँचवां पुनरीक्षण)

Hexagon Head Bolts, Screws and  
Nuts of Product Grades A and B  
Part 4 Hexagon Thin Nuts  
(Size Range M 1.6 to M 64)  
( Fifth Revision )

ICS 21.060.20

© BIS 2024

© ISO 2023



भारतीय मानक ब्यूरो  
BUREAU OF INDIAN STANDARDS  
मानक भवन, 9 बहादुर शाह ज़फर मार्ग, नई दिल्ली - 110002  
MANAK BHAVAN, 9 BAHADUR SHAH ZAFAR MARG  
NEW DELHI - 110002  
[www.bis.gov.in](http://www.bis.gov.in) [www.standardsbis.in](http://www.standardsbis.in)



## NATIONAL FOREWORD

This Indian Standard (Part 4) (Fifth Revision) which is identical to ISO 4035 : 2023 'Fasteners — Hexagon thin nuts (style 0)' issued by the International Organization for Standardization (ISO) was adopted by the Bureau of Indian Standards on the recommendation of the General Engineering and Fasteners Standards Sectional Committee and approval of the Production and General Engineering Division Council.

IS 1364 (Part 4) was originally published in 1960 and subsequently revised in 1967, 1983, 1992 and 2003. The third revision of this standard was identical with ISO 4035 : 1988. Fourth revision of this standard was identical with ISO 4035 : 1999. The fifth revision of this standard has been undertaken to align it with the latest version of ISO 4035.

The major changes in this revision are as follows:

- a) The use of thin nuts and a warning in relation to lower thread stripping resistance have been added in the scope;
- b) Nuts with size  $D < M5$  and  $D > M39$  (with  $m_{\min} < 0.8D$  not included in IS 1367 (Part 6) and IS 1367 (Part 14/Sec 2) have been dealt with in normative Annex A;
- c) Size M7 has been added;
- d) Dimensions of  $d_{a,\max}$ ,  $d_{w,\min}$  and  $m_{w,\min}$  have been specified with two decimal places;
- e) Dimension  $d_{w,\min}$  for sizes  $D \leq M5$  has been changed from  $s_{\min} - IT16$  to  $s_{\min} - IT15$  in order to have a larger bearing surface area and thus less contact pressure;
- f) For steel nuts, quenching and tempering condition has been specified in accordance with IS 1367 (Part 6);
- g) For stainless steel nuts, grades D4 and D6 and property classes 040 have been added;
- h) Non-ferrous metal nuts have been deleted (as a consequence of the withdrawal of ISO 8839); and
- j) Specifications for marking and labelling have been added as clause 6.

This standard has been published in 6 parts. Other parts in this series are:

- Part 1 Hexagon head bolts (Size range M1.6 to M64);
- Part 2 Hexagon head screws (Size range M1.6 to M64);
- Part 3 Hexagon nuts, Style 1 (Size range M1.6 to M64);
- Part 5 Hexagon thin nuts — Product grade B (Unchamfered) (Size range M1.6 to M10); and
- Part 6 Hexagon nuts, style 2.

The text of ISO standard has been approved as suitable for publication as an Indian Standard without deviations. Certain conventions are, however, not identical to those used in Indian Standards. Attention is particularly drawn to the following:

- a) Wherever the words 'International Standard' appear referring to this standard, they should be read as 'Indian Standard'; and
- b) Comma (,) has been used as a decimal marker while in Indian Standards, the current practice is to use a point (.) as the decimal marker.

In this adopted standard, reference appears to certain International Standards for which Indian Standards also exist. The corresponding Indian Standards, which are to be substituted in their respective places, are listed below along with their degree of equivalence for the editions indicated:

<i>International Standard</i>	<i>Corresponding Indian Standard</i>	<i>Degree of Equivalence</i>
ISO 225 Fasteners — Bolts, screws, studs and nuts — Symbols and descriptions of dimensions	IS 8536 : 2021/ISO 225 : 2010 Fasteners — Bolts, screws, studs and nuts — Symbols and descriptions of dimensions ( <i>second revision</i> )	Identical
ISO 898-2 Fasteners — Mechanical properties of fasteners made of carbon steel and alloy steel — Part 2: Nuts with specified property classes	IS 1367 (Part 6) : 2024/ISO 898-2 : 2022 Technical supply conditions for threaded steel fasteners: Part 6 Mechanical properties of fasteners made of carbon steel and alloy steel — Nuts with specified property classes — Coarse thread and fine pitch thread ( <i>fifth revision</i> )	Identical
ISO 965-1 ISO general purpose metric screw threads — Tolerances — Part 1: Principles and basic data	IS 14962 (Part 1) : 2018/ISO 965-1 : 2013 ISO general purpose metric screw threads — Tolerances: Part 1 Principles and basic data ( <i>first revision</i> )	Identical
ISO 1891-4 Fasteners — Vocabulary — Part 4: Control, inspection, delivery, acceptance and quality	IS XXXX (Part 4) : 2024/ISO 1891- 4 : 2018 Fasteners — Vocabulary: Part 4 Control, inspection, delivery, acceptance and quality	Identical
ISO 3269 Fasteners — Acceptance inspection	IS 1367 (Part 17) : 2023/ISO 3269 : 2019 Technical supply conditions for threaded steel fasteners: Part 17 Inspections, sampling and acceptance procedure ( <i>fifth revision</i> )	Identical
ISO 3506-2 Fasteners — Mechanical properties of corrosion-resistant stainless steel fasteners — Part 2: Nuts with specified grades and property classes	IS 1367 (Part 14/Sec 2) : 2023/ISO 3506-2 : 2020 Technical supply conditions for threaded steel fasteners: Part 14 Mechanical properties of corrosion-resistant stainless-steel fasteners, Section 2 Nuts with specified grades and property classes ( <i>fifth revision</i> )	Identical
ISO 4042 Fasteners — Electroplated coating systems	IS 1367 (Part 11) : 2024/ISO 4042 : 2022 Technical supply conditions for threaded steel fasteners: Part 11 Electroplated coating systems ( <i>fifth revision</i> )	Identical
ISO 4759-1 Tolerances for fasteners — Part 1: Bolts, screws, studs and nuts — Product grades A, B and C	IS 1367 (Part 2) : 2002/ISO 4759-1 : 2000 Technical supply conditions for threaded steel fasteners: Part 2 Tolerances for fasteners — Bolts, screws, studs and nuts — Product grades A, B and C ( <i>third revision</i> )	Identical
ISO 6157-2 Fasteners — Surface discontinuities — Part 2: Nuts	IS 1367 (Part 10) : 2002/ISO 6157-2 : 1995 Technical supply conditions for threaded steel fasteners: Part 10 Surface discontinuities — Nuts ( <i>third revision</i> )	Identical

<i>International Standard</i>	<i>Corresponding Indian Standard</i>	<i>Degree of Equivalence</i>
ISO 8991 Designation system for fasteners	IS 1367 (Part 16) : 2002/ ISO 8991 : 1986 Technical supply conditions for threaded steel fasteners: Part 16 Designation system for fasteners ( <i>third revision</i> )	Identical
ISO 8992 Fasteners — General requirements for bolts, screws, studs and nuts	IS 1367 (Part 1) : 2014/ISO 8992 : 2005 Technical supply conditions for threaded steel fasteners: Part 1 General requirements for bolts, screws, studs and nuts ( <i>fourth revision</i> )	Identical
ISO 10683 Fasteners — Non-electrolytically applied zinc flake coating systems	IS/ISO 10683 : 2018 Fasteners — Non-electrolytically applied zinc flake coating systems	Identical
ISO 10684 Fasteners — Hot dip galvanized coatings	IS 1367 (Part 13) : 2020/ISO 10684 : 2004 Technical supply conditions for threaded steel fasteners: Part 13 Hot dip galvanized coatings on threaded fasteners ( <i>third revision</i> )	Identical

The standard also makes a reference to the BIS Certification Marking and packaging of the product. Details of which are given in National Annex A.

For the purpose of deciding whether a particular requirement of this standard is complied with, the final value, observed or calculated expressing the result of a test or analysis, shall be rounded off in accordance with IS 2 : 2022 'Rules for rounding off numerical values (*second revision*).' The number of significant places retained in the rounded off value should be the same as that of the specified value in this standard.



# Contents

Page

<b>1</b>	<b>Scope</b> .....	<b>1</b>
<b>2</b>	<b>Normative references</b> .....	<b>1</b>
<b>3</b>	<b>Terms and definitions</b> .....	<b>1</b>
<b>4</b>	<b>Dimensions</b> .....	<b>2</b>
<b>5</b>	<b>Requirements and reference International Standards</b> .....	<b>4</b>
<b>6</b>	<b>Marking and labelling</b> .....	<b>5</b>
	6.1 Marking on product.....	5
	6.2 Labelling on package.....	5
<b>7</b>	<b>Designation</b> .....	<b>5</b>
<b>Annex A (normative)</b>	<b>Nuts with <math>D &lt; M5</math> and <math>D &gt; M39</math>, not included in ISO 898-2 and ISO 3506-2</b> .....	<b>6</b>
<b>Bibliography</b> .....		<b>10</b>
<b>National Annex A</b> .....		<b>11</b>





*Indian Standard*

HEXAGON HEAD BOLTS, SCREWS AND NUTS OF PRODUCT  
GRADES A AND B

**PART 4 HEXAGON THIN NUTS (SIZE RANGE M1.6 TO M64)**

( *Fifth Revision* )

## 1 Scope

This document specifies the characteristics of hexagon thin nuts (style 0), in steel and stainless steel, with metric coarse pitch thread M1,6 to M64, and with product grades A and B.

Thin nuts used as jam nuts are to be assembled together with a regular or high nut.

**WARNING — Thin nuts (style 0) have a reduced loadability compared to regular nuts or high nuts, and are not designed to provide resistance to thread stripping (see ISO 898-2).**

If in certain cases other specifications are requested, stainless steel grades and property classes can be selected from ISO 3506-2.

## 2 Normative references

The following documents are referred to in the text in such a way that some or all of their content constitutes requirements of this document. For dated references, only the edition cited applies. For undated references, the latest edition of the referenced document (including any amendments) applies.

ISO 225, *Fasteners — Bolts, screws, studs and nuts — Symbols and descriptions of dimensions*

ISO 898-2, *Fasteners — Mechanical properties of fasteners made of carbon steel and alloy steel — Part 2: Nuts with specified property classes*

ISO 965-1, *ISO general purpose metric screw threads — Tolerances — Part 1: Principles and basic data*

ISO 1891-4, *Fasteners — Vocabulary — Part 4: Control, inspection, delivery, acceptance and quality*

ISO 3269, *Fasteners — Acceptance inspection*

ISO 3506-2, *Fasteners — Mechanical properties of corrosion-resistant stainless steel fasteners — Part 2: Nuts with specified grades and property classes*

ISO 4042, *Fasteners — Electroplated coating systems*

ISO 4759-1, *Tolerances for fasteners — Part 1: Bolts, screws, studs and nuts — Product grades A, B and C*

ISO 6157-2, *Fasteners — Surface discontinuities — Part 2: Nuts*

ISO 8991, *Designation system for fasteners*

ISO 8992, *Fasteners — General requirements for bolts, screws, studs and nuts*

ISO 10683, *Fasteners — Non-electrolytically applied zinc flake coating systems*

ISO 10684, *Fasteners — Hot dip galvanized coatings*

## 3 Terms and definitions

No terms and definitions are listed in this document.

ISO and IEC maintain terminology databases for use in standardization at the following addresses:

— ISO Online browsing platform: available at <https://www.iso.org/obp>

— IEC Electropedia: available at <https://www.electropedia.org/>

## 4 Dimensions

Dimensions for nuts with sizes M5 to M39 shall be in accordance with [Figure 1](#) and with [Tables 1](#) and [2](#).  
Dimensions for nuts with sizes  $D < M5$  and  $D > M39$  shall be in accordance with [Annex A](#).

Symbols and descriptions of dimensions are specified in ISO 225.

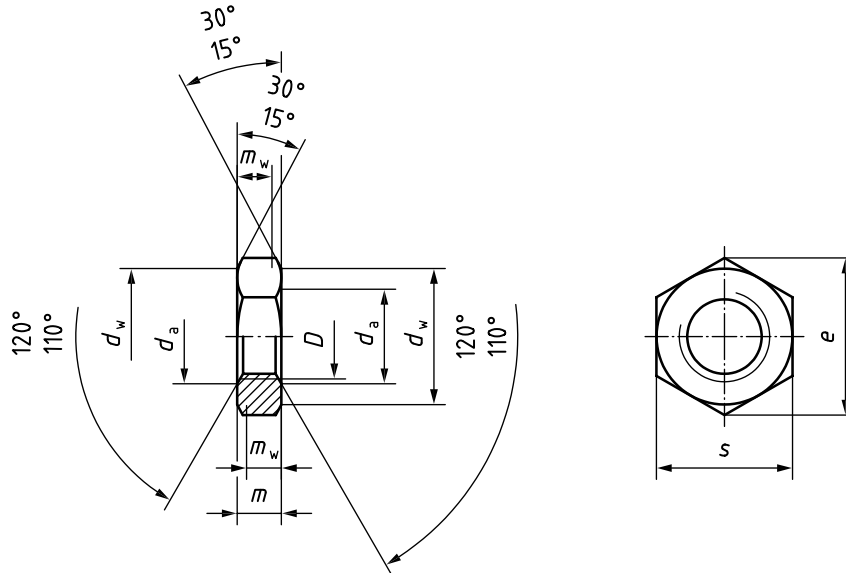

Figure 1 — Hexagon thin nut

**Table 1 — Dimensions for nuts M5 to M16 (product grade A)**

Dimensions in millimetres

Thread, <i>D</i>		<b>M5</b>	<b>M6</b>	(M7)	<b>M8</b>	<b>M10</b>	<b>M12</b>	(M14)	<b>M16</b>
<i>P</i> <sup>a</sup>		0,8	1	1	1,25	1,5	1,75	2	2
<i>d</i> <sub>a</sub>	max.	5,75	6,75	7,75	8,75	10,80	12,96	15,12	17,28
	min.	5,00	6,00	7,00	8,00	10,00	12,00	14,00	16,00
<i>d</i> <sub>w</sub>	min.	7,20	8,88	9,63	11,63	14,63	16,63	19,64	22,49
<i>e</i>	min.	8,79	11,05	12,12	14,38	17,77	20,03	23,36	26,75
<i>m</i>	max.	2,70	3,20	3,70	4,00	5,00	6,00	7,00	8,00
	min.	2,45	2,90	3,40	3,70	4,70	5,70	6,42	7,42
<i>m</i> <sub>w</sub>	min.	1,96	2,32	2,72	2,96	3,76	4,56	5,14	5,94
<i>s</i>	nom. = max.	8,00	10,00	11,00	13,00	16,00	18,00	21,00	24,00
	min.	7,78	9,78	10,73	12,73	15,73	17,73	20,67	23,67

NOTE Sizes shown in brackets are non-preferred.  
<sup>a</sup> *P* is the pitch of the thread.

**Table 2 — Dimensions for nuts M18 to M39 (product grade B)**

Dimensions in millimetres

Thread, <i>D</i>		(M18)	<b>M20</b>	(M22)	<b>M24</b>	(M27)	<b>M30</b>	(M33)	<b>M36</b>	(M39)
<i>P</i> <sup>a</sup>		2,5	2,5	2,5	3	3	3,5	3,5	4	4
<i>d</i> <sub>a</sub>	max.	19,44	21,60	23,76	25,92	29,16	32,40	35,64	38,88	42,12
	min.	18,00	20,00	22,00	24,00	27,00	30,00	33,00	36,00	39,00
<i>d</i> <sub>w</sub>	min.	24,85	27,70	31,35	33,25	38,00	42,75	46,55	51,11	55,86
<i>e</i>	min.	29,56	32,95	37,29	39,55	45,20	50,85	55,37	60,79	66,44
<i>m</i>	max.	9,00	10,00	11,00	12,00	13,50	15,00	16,50	18,00	19,50
	min.	8,42	9,10	9,90	10,90	12,40	13,90	15,40	16,90	18,20
<i>m</i> <sub>w</sub>	min.	6,74	7,28	7,92	8,72	9,92	11,12	12,32	13,52	14,56
<i>s</i>	nom. = max.	27,00	30,00	34,00	36,00	41,00	46,00	50,00	55,00	60,00
	min.	26,16	29,16	33,00	35,00	40,00	45,00	49,00	53,80	58,80

NOTE Sizes shown in brackets are non-preferred.  
<sup>a</sup> *P* is the pitch of the thread.

## 5 Requirements and reference International Standards

The requirements specified in the International Standards referenced in [Table 3](#) shall apply. For nuts with sizes  $D < M5$  and  $D > M39$ , [Annex A](#) shall apply.

**Table 3 — Requirements and reference International Standards**

Material		Steel	Stainless steel	
<b>General requirements</b>	International Standard	ISO 8992		
<b>Thread</b>	Tolerance class	6H <sup>a</sup>		
	International Standard	ISO 965-1		
<b>Mechanical properties</b>	Style	0		
	Property class	$M5 \leq D \leq M39$	04 <sup>b</sup> , 05 <sup>c</sup>	
	Symbol	$D < M5$ and $D > M39$	<a href="#">Annex A</a>	
	Grade <sup>d</sup> and property class Symbol	—	$M5 \leq D \leq M24$	A2-035, A4-035, A4-040, D4-040, D6-040
			$M24 < D \leq M39$	A2-025, A2-035, A4-025, A4-035, D4-035, D6-035
			$D < M5$ and $D > M39$	<a href="#">Annex A</a>
International Standard	ISO 898-2	ISO 3506-2		
<b>Tolerances</b>	Product grade	$D \leq M16$ : A (except for M5 where $d_{w,min} = s_{min} - IT15$ )	$D > M16$ : B	
	International Standard	ISO 4759-1		
<b>Surface condition</b>	As processed (no coating) Electroplated coatings as specified in ISO 4042 Non-electrolytically applied zinc flake coatings as specified in ISO 10683 Hot dip galvanized coatings as specified in ISO 10684 Other finishes, coatings and/or additional requirements shall be agreed between the purchaser and the supplier	Clean and bright and/or Passivated <sup>e</sup>		
<b>Surface integrity</b>	Limits for surface discontinuities as specified in ISO 6157-2	As agreed <sup>f</sup>		
<b>Acceptability</b>	Acceptance inspection as specified in ISO 3269			

<sup>a</sup> Depending on the type of coating to be applied, another tolerance position of the thread may be specified for the uncoated nuts in accordance with the relevant coating standard.

<sup>b</sup> Shall not be quenched and tempered in accordance with ISO 898-2 (NQT nuts).

<sup>c</sup> Shall be quenched and tempered in accordance with ISO 898-2 (QT nuts).

<sup>d</sup> The most common stainless steel grades are A2 and A4; however, depending on the application, it can be necessary to select other grades in ISO 3506-2 suitable for the service corrosive environment. For use at high temperatures (up to 800 °C), mechanical properties are specified in ISO 3506-5. See also ISO 3506-6 for the selection of suitable stainless steel grades.

<sup>e</sup> See e.g. ISO 16048.

<sup>f</sup> See e.g. ISO 6157-2.

## 6 Marking and labelling

### 6.1 Marking on product

Marking shall be:

- for steel nuts, as specified in ISO 898-2,
- for stainless steel nuts, as specified in ISO 3506-2.

### 6.2 Labelling on package

Labelling on the package shall be in accordance with ISO 898-2 or ISO 3506-2, and shall include at least:

- the reference to this document, i.e. ISO 4035,
- the thread size  $D$ ,
- for steel nuts, the symbol of the property class,
- for stainless steel nuts, the grade and symbol of the property class,
- the type of surface condition (finish and/or coating),
- the manufacturer's and/or distributor's identification and/or name,
- the manufacturing lot number as specified in ISO 1891-4,
- the quantity of pieces in the package.

## 7 Designation

The designation requirements as specified in ISO 8991 shall apply with:

- for steel nuts, the symbol of the property class as specified in ISO 898-2,
- for stainless steel nuts, the grade and symbol of the property class as specified in ISO 3506-2.

When no specific surface condition (finish and/or coating) is specified in the designation, steel nuts are delivered in the as processed condition and stainless steel nuts in the clean and bright condition.

EXAMPLE 1 A hexagon thin nut (style 0) in accordance with this document, with thread size M12, product grade A, in steel, property class 05, as processed, is designated as follows:

**Hexagon thin nut ISO 4035 - M12 - 05**

EXAMPLE 2 A hexagon thin nut (style 0) in accordance with this document, with thread size M10, product grade A, in stainless steel grade A2 and property class 040, clean and bright, is designated as follows:

**Hexagon thin nut ISO 4035 - M10 - A2-040**

## Annex A (normative)

### Nuts with $D < M5$ and $D > M39$ , not included in ISO 898-2 and ISO 3506-2

#### A.1 Design of hexagon thin nuts (style 0)

Hexagon thin nuts (style 0) have been designed in accordance with the following:

- thin nuts with sizes  $M1,6 \leq D \leq M64$  have a minimum height  $m_{\min} \geq 0,45D$ , in accordance with ISO 898-2 and ISO 3506-2;
- thin nuts with sizes  $M1,6 \leq D \leq M64$  have a maximum height  $m_{\max} \geq 0,5D$ ;
- mechanical properties are not included in ISO 898-2 and ISO 3506-2 for thin nuts with sizes  $D < M5$  and  $D > M39$ , they are specified in this [Annex A](#).

## A.2 Dimensions

Dimensions shall be in accordance with [Figure 1](#) and with [Tables A.1](#) and [A.2](#).

**Table A.1 — Nuts with  $D < M5$  (product grade A)**

Dimensions in millimetres

Thread, $D$		<b>M1,6</b>	<b>M2</b>	<b>M2,5</b>	<b>M3</b>	(M3,5)	<b>M4</b>
$P^a$		0,35	0,4	0,45	0,5	0,6	0,7
$d_a$	max.	1,84	2,30	2,88	3,45	4,03	4,60
	min.	1,60	2,00	2,50	3,00	3,50	4,00
$d_w$	min.	2,54	3,34	4,34	4,84	5,34	6,20
$e$	min.	3,41	4,32	5,45	6,01	6,58	7,66
$m$	max.	1,00	1,20	1,60	1,80	2,00	2,20
	min.	0,75	0,95	1,35	1,55	1,75	1,95
$m_w$	min.	0,60	0,76	1,08	1,24	1,40	1,56
$s$	nom. = max.	3,20	4,00	5,00	5,50	6,00	7,00
	min.	3,02	3,82	4,82	5,32	5,82	6,78
NOTE Size shown in brackets is non-preferred.							
<sup>a</sup> $P$ is the pitch of the thread.							

**Table A.2 — Nuts with  $D > M39$  (product grade B)**

Dimensions in millimetres

Thread, $D$		<b>M42</b>	(M45)	<b>M48</b>	(M52)	<b>M56</b>	(M60)	<b>M64</b>
$P^a$		4,5	4,5	5	5	5,5	5,5	6
$d_a$	max.	45,36	48,60	51,84	56,16	60,48	64,80	69,12
	min.	42,00	45,00	48,00	52,00	56,00	60,00	64,00
$d_w$	min.	59,95	64,70	69,45	74,20	78,66	83,41	88,16
$e$	min.	71,30	76,95	82,60	88,25	93,56	99,21	104,86
$m$	max.	21,00	22,50	24,00	26,00	28,00	30,00	32,00
	min.	19,70	21,20	22,70	24,70	26,70	28,70	30,40
$m_w$	min.	15,76	16,96	18,16	19,76	21,36	22,96	24,32
$s$	nom. = max.	65,00	70,00	75,00	80,00	85,00	90,00	95,00
	min.	63,10	68,10	73,10	78,10	82,80	87,80	92,80
NOTE Sizes shown in brackets are non-preferred.								
<sup>a</sup> $P$ is the pitch of the thread.								

### A.3 Requirements and reference International Standards

For thin nuts with sizes  $D < M5$  and  $D > M39$ , the requirements specified in the International Standards referenced in [Tables A.3](#) and [A.4](#) shall apply.

**Table A.3 — Requirements and reference International Standards**

Material		Steel	Stainless steel
<b>General requirements</b>	International Standard	ISO 8992	
<b>Thread</b>	Tolerance class	6H <sup>a</sup>	
	International Standard	ISO 965-1	
<b>Mechanical properties</b>	Style	0	
	Property class	$D < M5$ and $D > M39$	04 <sup>b</sup> , 05 <sup>c</sup>
	Symbol		—
	Grade <sup>d</sup> and property class	—	$D < M5$ A2-035, A4-035, A4-040, D4-040, D6-040
	Symbol	—	$D > M39$ A2-025, A2-035, A4-025, A4-035, D4-035, D6-035
International Standard	<a href="#">Table A.4</a> and ISO 898-2		
<b>Tolerances</b>	Product grade	$D < M5$ : A (except for $d_{w,min} = s_{min} - IT15$ )	$D > M39$ : B
	International Standard	ISO 4759-1	
<b>Surface condition</b>	As processed (no coating) Electroplated coatings as specified in ISO 4042 Non-electrolytically applied zinc flake coatings as specified in ISO 10683 Hot dip galvanized coatings as specified in ISO 10684 Other finishes, coatings and/or additional requirements shall be agreed between the purchaser and the supplier	Clean and bright and/or Passivated <sup>e</sup>	
<b>Surface integrity</b>	As agreed <sup>f</sup>		
<b>Acceptability</b>	Acceptance inspection as specified in ISO 3269		

<sup>a</sup> Depending on the type of coating to be applied, another tolerance position of the thread may be specified for the uncoated nuts in accordance with the relevant coating standard.

<sup>b</sup> Shall not be quenched and tempered in accordance with ISO 898-2 (NQT nuts).

<sup>c</sup> Shall be quenched and tempered in accordance with ISO 898-2 (QT nuts).

<sup>d</sup> The most common stainless steel grades are A2 and A4; however, depending on the application, it can be necessary to select other grades in ISO 3506-2 suitable for the service corrosive environment. For use at high temperatures (up to 800 °C), mechanical properties are specified in ISO 3506-5. See also ISO 3506-6 for the selection of suitable stainless steel grades.

<sup>e</sup> See e.g. ISO 16048.

<sup>f</sup> See e.g. ISO 6157-2.



**Table A.4 — Mechanical properties for nuts with  $D < M5$  and  $D > M39$   
(not included in ISO 898-2 and ISO 3506-2)**

Property class	Steel thin nuts (style 0)		Stainless steel thin nuts (style 0)		
	04	05	025	035	040
Stress under proof load, $S_p$ (MPa)	380	500	250	350	400
	<b>Proof load, <math>F_p</math><sup>a</sup> (N)</b>				
<b>M1,6</b>	490	640	320	450	510
<b>M2</b>	790	1 040	520	730	830
<b>M2,5</b>	1 290	1 700	850	1 190	1 360
<b>M3</b>	1 920	2 520	1 260	1 770	2 020
<b>M3,5</b>	2 580	3 390	1 700	2 380	2 720
<b>M4</b>	3 340	4 390	2 200	3 080	3 520
<b>M42</b>	426 000	560 500	280 300	392 400	448 400
<b>M45</b>	496 300	653 100	326 600	457 200	522 500
<b>M48</b>	559 800	736 600	368 300	515 700	589 300
<b>M52</b>	668 000	879 000	439 500	615 300	703 200
<b>M56</b>	771 500	1 015 100	507 600	710 600	812 100
<b>M60</b>	897 600	1 181 100	590 600	826 800	944 900
<b>M64</b>	1 016 900	1 338 000	669 000	936 600	1 070 400
	<b>Hardness</b>				
Vickers hardness	min.	188 HV	272 HV	—	
	max.	334 HV	353 HV		
Converted Brinell Hardness <sup>b</sup>	min.	179 HB	268 HBW		
	max.	318 HB	349 HBW		
Converted Rockwell Hardness <sup>b</sup>	min.	88,8 HRB	26,5 HRC		
	max.	33,9 HRC	36,9 HRC		
<sup>a</sup> $F_p = A_{s,nom} \times S_p$ . For the calculation of $A_{s,nom}$ , see ISO 898-2. The proof load values are calculated by using the exact data for $A_s$ , and only at the end the values are rounded to the next upper 10 N up to 100 000 N, and to the next upper 100 N above.					
<sup>b</sup> Brinell and Rockwell hardness are converted from HV values according to ISO 18265 (unalloyed and low allowed steel conditions for property class 04, quenched and tempered condition for property class 05).					

#### A.4 Marking and labelling

Marking and labelling shall be in accordance with [Clause 6](#).

#### A.5 Designation

Designation shall be in accordance with [Clause 7](#).

## Bibliography

- [1] ISO 3506-5, *Fasteners — Mechanical properties of corrosion-resistant stainless steel fasteners — Part 5: Special fasteners (also including fasteners from nickel alloys) for high temperature applications*
- [2] ISO 3506-6, *Fasteners — Mechanical properties of corrosion-resistant stainless steel fasteners — Part 6: General rules for the selection of stainless steels and nickel alloys for fasteners*
- [3] ISO 16048, *Passivation of corrosion-resistant stainless-steel fasteners*
- [4] ISO 18265, *Metallic materials — Conversion of hardness values*

**National Annex A**

( *National Foreword* )

**A-1 PACKAGING**

The packaging of hexagon head nuts shall be in accordance with IS 1367 (Part 18) : 1996 'Industrial fasteners — Threaded steel fasteners — Technical supply conditions: Part 18 Packaging'.

**A-2 BIS CERTIFICATION MARKING**

The product(s) conforming to the requirements of this standard may be certified as per the conformity assessment schemes under the provisions of the *Bureau of Indian Standards Act, 2016* and the Rules and Regulations frames thereunder, and the product(s) may be marked with the Standard Mark.





## Bureau of Indian Standards

BIS is a statutory institution established under the *Bureau of Indian Standards Act, 2016* to promote harmonious development of the activities of standardization, marking and quality certification of goods and attending to connected matters in the country.

### Copyright

BIS has the copyright of all its publications. No part of these publications may be reproduced in any form without the prior permission in writing of BIS. This does not preclude the free use, in the course of implementing the standard, of necessary details, such as symbols and sizes, type or grade designations. Enquiries relating to copyright be addressed to the Head (Publication & Sales), BIS.

### Review of Indian Standards

Amendments are issued to standards as the need arises on the basis of comments. Standards are also reviewed periodically; a standard along with amendments is reaffirmed when such review indicates that no changes are needed; if the review indicates that changes are needed, it is taken up for revision. Users of Indian Standards should ascertain that they are in possession of the latest amendments or edition by referring to the website-[www.bis.gov.in](http://www.bis.gov.in) or [www.standardsbis.in](http://www.standardsbis.in).

This Indian Standard has been developed from Doc No.: PGD 37 (22752).

### Amendments Issued Since Publication

Amend No.	Date of Issue	Text Affected

## BUREAU OF INDIAN STANDARDS

### Headquarters:

Manak Bhavan, 9 Bahadur Shah Zafar Marg, New Delhi 110002

Telephones: 2323 0131, 2323 3375, 2323 9402

Website: [www.bis.gov.in](http://www.bis.gov.in)

### Regional Offices:

	Telephones
Central : 601/A, Konnectus Tower -1, 6 <sup>th</sup> Floor, DMRC Building, Bhavbhuti Marg, New Delhi 110002	{ 2323 7617
Eastern : 8 <sup>th</sup> Floor, Plot No 7/7 & 7/8, CP Block, Sector V, Salt Lake, Kolkata, West Bengal 700091	{ 2367 0012 2320 9474
Northern : Plot No. 4-A, Sector 27-B, Madhya Marg, Chandigarh 160019	{ 265 9930
Southern : C.I.T. Campus, IV Cross Road, Taramani, Chennai 600113	{ 2254 1442 2254 1216
Western : Manakalya, 4 <sup>th</sup> Floor, NTH Complex (W Sector), F-10, MIDC, Andheri (East), Mumbai 400093	{ 283 25838

**Branches :** AHMEDABAD, BENGALURU, BHOPAL, BHUBANESHWAR, CHANDIGARH, CHENNAI, COIMBATORE, DEHRADUN, DELHI, FARIDABAD, GHAZIABAD, GUWAHATI, HARYNA, HUBLI, HYDERABAD, JAIPUR, JAMMU & KASHMIR, JAMSHEDPUR, KOCHI, KOLKATA, LUCKNOW, MADURAI, MUMBAI, NAGPUR, NOIDA, PARWANOO, PATNA, PUNE, RAIPUR, RAJKOT, SURAT, VIJAYAWADA.