

PRELIMINARY DRAFT FOR INDIAN STANDARD

ETD 15 Doc. (17922)

Motors for submersible pumpsets - Specification (Third Revision) Revision of Indian Standard (IS 9283 : 2013)

Rotating Machinery Sectional Committee, ETD 15

FOREWORD

This draft Indian Standard (Third Revision) was adopted by the Bureau of Indian Standards, after the draft finalized by the Rotating Machinery Sectional Committee had been approved by the Electrotechnical Division Council.

This standard shall be read in conjunction with IS 8034 : 2018 'IS 8034:2018 'Submersible pumpsets - Specification (Third Revision)' and IS 14220 : 2018 'Openwell submersible pumpsets - Specification (First Revision)' as the submersible motor and the submersible pump together form a complete set. Coordination in the selection of motor and pump with respect to their size, rating and output, etc, is necessary for satisfactory and efficient operation of the pumpset.

The general requirements of 3-phase induction motors are covered in IS 12615: 2018 'Line operated three phase AC motors (IE Code) "Efficiency classes and performance specification" (Third Revision)' and requirements of single phase a.c. motors are specified in IS 996 : 2009 'Single-phase ac induction motors for general purpose (third revision)'. The requirements of 3-phase squirrel cage induction motors for centrifugal pumps are covered in IS 7538 : 1996 'Three-phase squirrel cage induction motors for centrifugal pumps for agricultural applications (first revision)'. The detailed procedure for conducting tests on motors are given in IS 4029 : 2010 'Guide for testing three-phase induction motors (first revision)' and IS 7572 : 1974 'Guide for testing single-phase ac and universal motors' as relevant.

In this revision the following have been added:

- a) Values of Performance Characteristics for 2-Pole Three-Phase Submersible Motor — Oil Filled (Suitable for Bore Size 150 mm and Maximum outside Diameter of Motor 146 mm)
- b) Three efficiency levels for 2-Pole Three-Phase Submersible Motors (all performance characteristics tables).

Also, reference should be made to IS 10804 (Part 2): 2018 'Recommended pumping system for agricultural purposes: Part 2 submersible pump sets (Third Revision)'.

For the purpose of deciding whether a particular requirement of this standard is complied with, the final value, observed or calculated, expressing the result of a test or analysis, shall be rounded off in accordance with IS 2 : 1960 'Rules for rounding off numerical values (*revised*)'. The number of significant places retained in the rounded off value should be the same as that of the specified value in this standard.

1 SCOPE

This standard specifies technical requirements of submersible motors for submersible pumpsets commonly used in bore holes (bore-wells or tube wells) and submersible pumpsets commonly used in open wells for handling clear, cold and fresh water for application in agriculture, water supply, etc.

2 REFERENCES

The standards listed at Annex A contain provisions, which through reference in this text, constitute provisions of this standard. At the time of publication, the editions indicated were valid. All standards are subject to revision, and parties to agreements based on this standard are encouraged to investigate the possibility of applying the most recent editions of the standards.

3 TERMINOLOGY

For the purpose of this standard, the definitions given in IS 1885 (Part 35) and the following shall apply.

3.1 Wet Type Water Filled Submersible Motors — It is a motor, which is completely filled with clear water (*see* Fig. 1).

3.2 Wet Type Oil Filled Submersible Motors — It is a motor, where winding as well as entire remaining space within the motor is filled with non toxic grade of oil and effectively sealed (*see* Fig. 2).

3.3 Resin Filled Submersible Motors — It is a motor, where stator is encapsulated and filled with an insulating compound. The remaining portion is filled with water or oil (*see* Fig. 3).

4 CHARACTERISTICS OF CLEAR, COLD AND FRESH WATER

4.1 Clear, cold, and fresh water means water having the characteristics specified below:

- a) Turbidity : 50 ppm (silica scale), *Max*
- b) Chlorides : 500 ppm, *Max*
- c) Total solids : 3000 ppm, *Max*
- d) pH value : 6.5 to 8.5
- e) Temperature : 33°C, *Max*
- f) Specific gravity : 1.004, *Max*
- g) Hardness (as CaCO₃) : 300 mg/litre, *Max*
(drinking water)

NOTE — If any other characteristics of water differ from these specified in 4.1, the pump details shall be as agreed to between the manufacturer/supplier and the user and shall be specified in the order.

5 CONSTRUCTION

5.1 The nomenclature of various components in the assembly of submersible pumpset is given in Fig. 1 to Fig. 3. The typical submersible pumpset installation is given in Fig. 4 for information.

5.1.1 The cable shall be insulated and sheathed with suitable polymer. It shall be flexible 3-core or 4-core flat type (or) with insulated leads. The requirements of the flat cable shall be as agreed between the manufacturer and the user. The size of the conductor shall be adequate and suitable for continuous use under water and in air.

5.1.2 The purchaser may specify the actual length of the cable required for the motor. In the absence of this information, the motor shall be supplied with a cable length of minimum 2 m.

5.1.3 In case a joint is required to be made between the lead cable supplied with the motor and the user's cable, a detailed procedure to make a watertight jointing shall be supplied by the motor manufacturer.

5.1.4 The size of the conductor and the length of cable should be suitably selected so that the voltage drop between the control panel and the motor terminals does not exceed three percent of the rated voltage.

5.2 Earthing

5.2.1 Motor shall have suitable provision for earthing to facilitate earthing of the motor as per IS 3043 at the time of installation.

5.2.2 In case GI pipes are used for the purpose of earthing the motor, earthing connection may be made to the discharge pipe clamps.

5.2.3 All the materials and components for the motors shall be suitable for application in respect of corrosion resistance and mechanical performance continuously

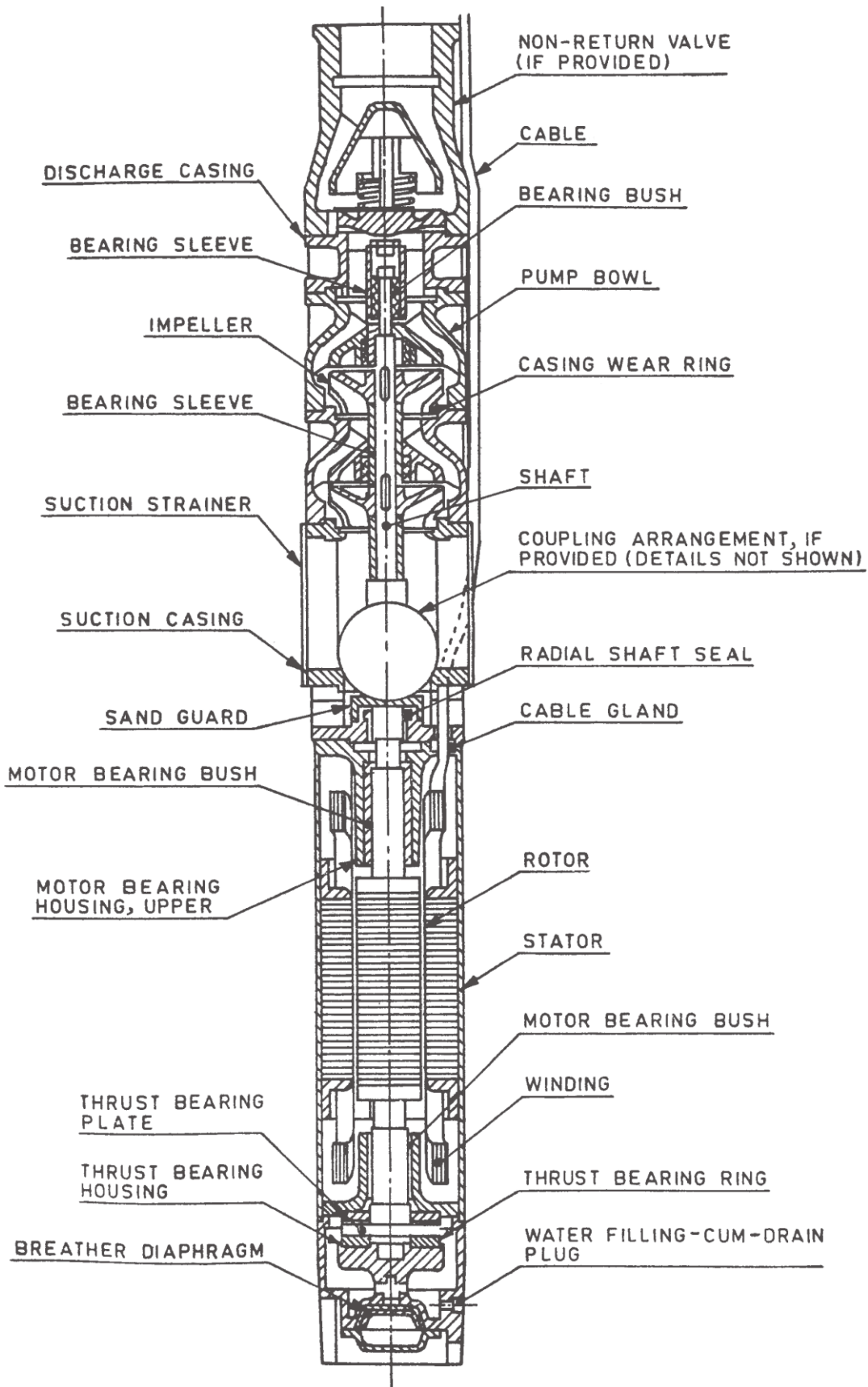

NOTE — This figure only illustrates the nomenclature of commonly used parts and does not specify any particular design feature.

FIG. 1 WET TYPE WATER FILLED SUBMERSIBLE MOTOR

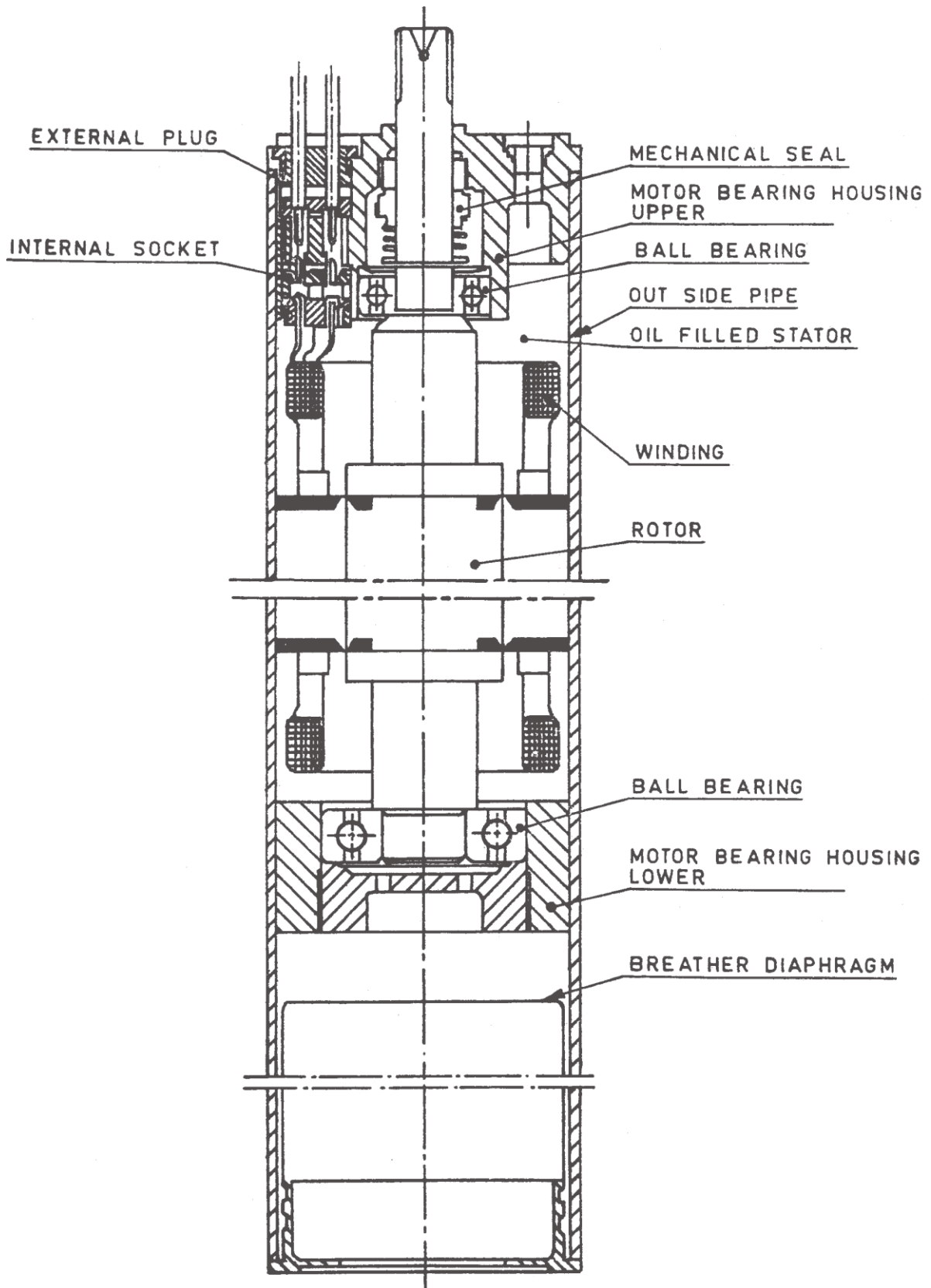

NOTE — This figure only illustrates the nomenclature of commonly used parts and does not specify any particular design feature.

FIG. 2 WET TYPE OIL FILLED SUBMERSIBLE MOTOR

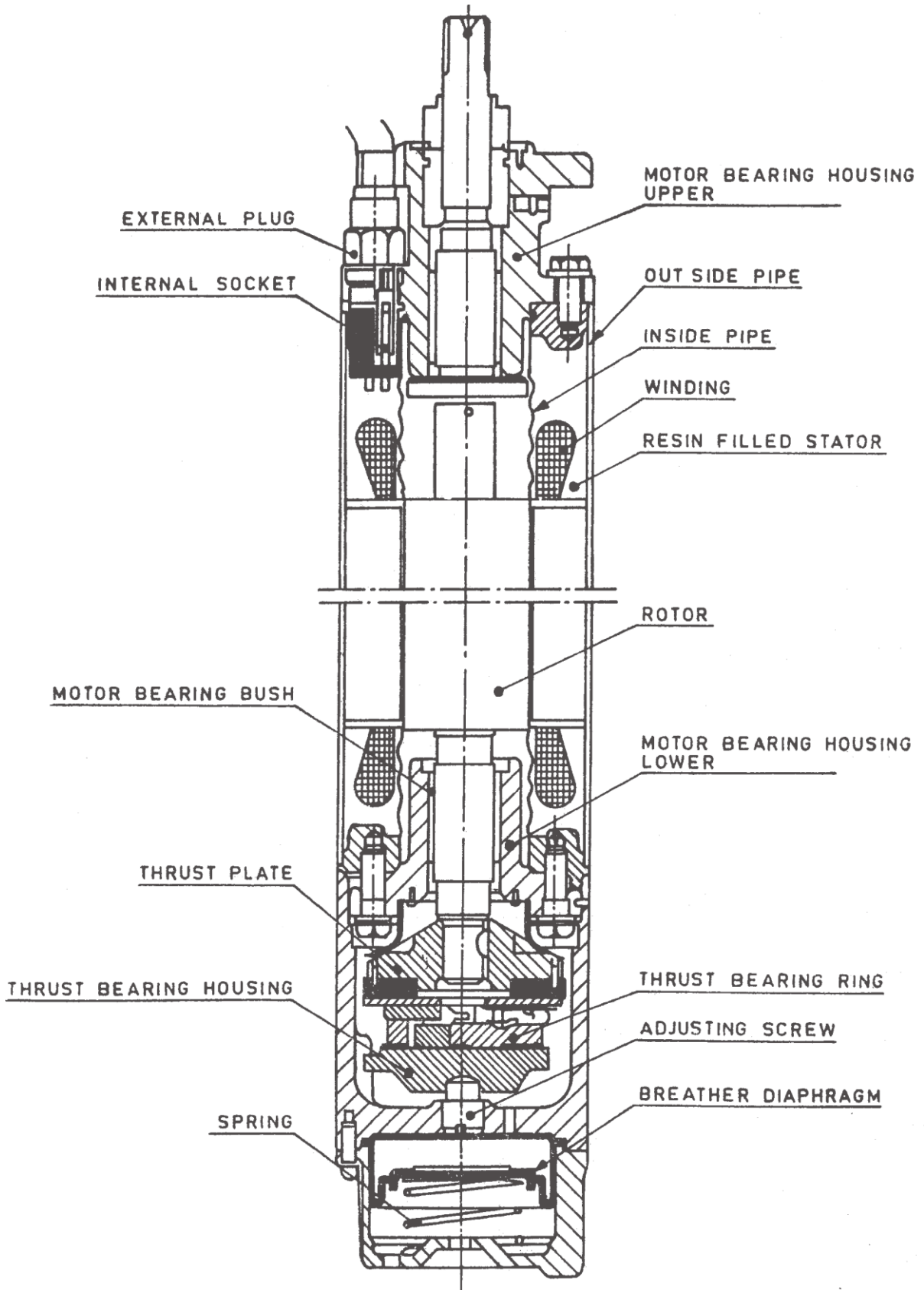

NOTE — This figure only illustrates the nomenclature of commonly used parts and does not specify any particular design feature.

FIG. 3 RESIN FILLED SUBMERSIBLE MOTOR

under water. The typical materials used in the submersible motors are given in Table 1 for the guidance of the manufacturer and the user.

5.2.4 The rotor of the wet type submersible motor shall be provided with suitable coating to protect it from corrosion under water.

5.2.5 The motor shall be provided with a breathing attachment like bellows, diaphragm, etc, to compensate the volumetric variation of water inside the motor due to changes in the temperature.

5.3 Foreign Matter

The motor shall be protected by means of cable glands, rubber seals, etc, from ingress of borewell water, sand and other foreign matter.

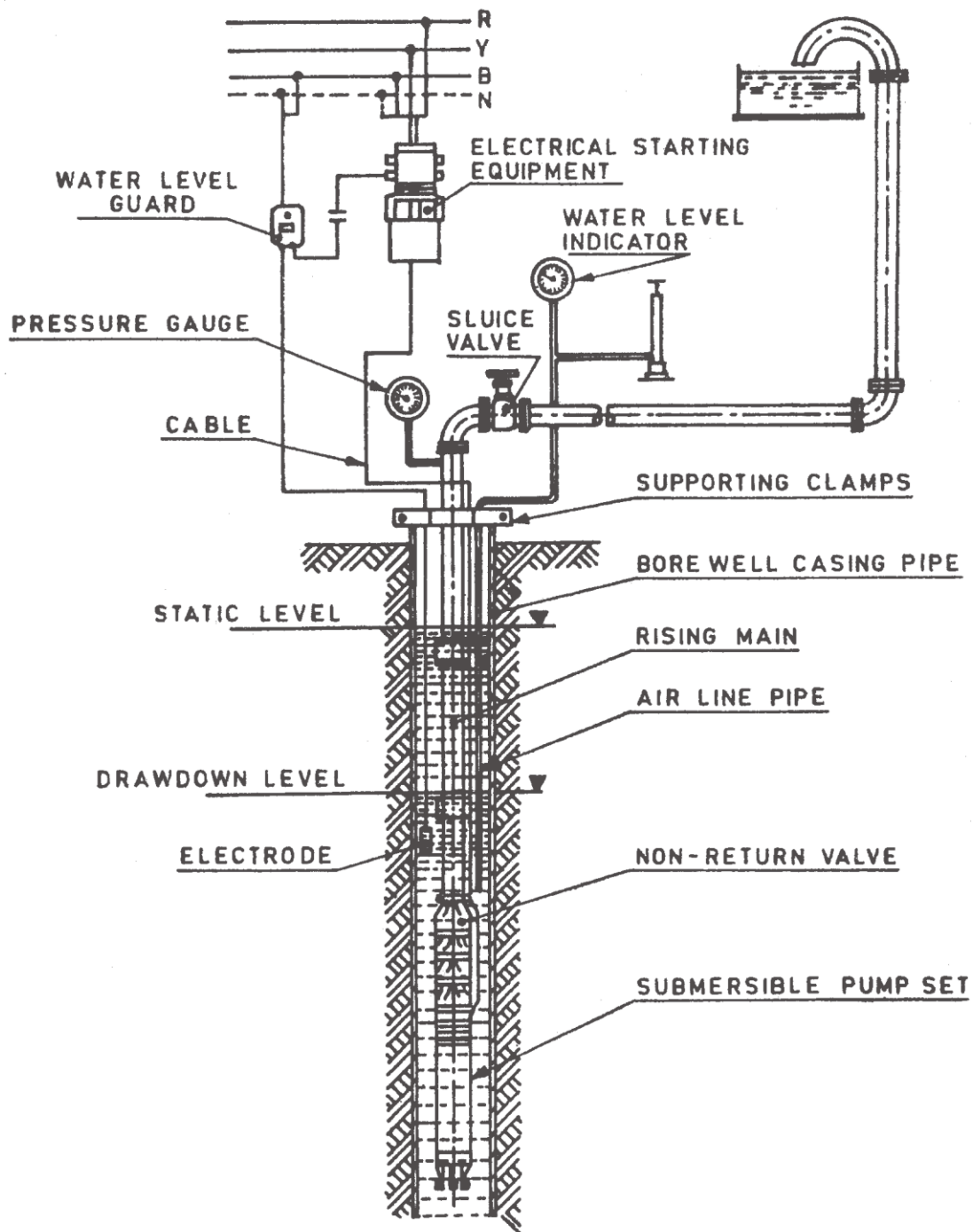

FIG. 4 TYPICAL SUBMERSIBLE PUMPSET INSTALLATION

Table 1 Typical Materials for the Parts of the Submersible Motor
(Clause 5.2.3)

SI No. (1)	Name of the Part (2)	Material (3)	Indian Standard and Grade, If Any (4)
i)	Bearing housing and base	Grey cast iron	IS 210 Gr FG 200
ii)	Motor shaft	Wrought steel or Chromium steel	IS 1873, C40 IS 1570 (Part 5) Gr 04 Cr 13, or 12 Cr 13, or 20 Cr 13
iii)	Bearing bush	Leaded tin bronze or Resin bonded carbon metal-clad or Rubber or Rubber-lined	IS 318, LTB 3 or LTB 4 or LTB 5
iv)	Rotor:		
	a) Laminations	Electrical sheet steel	IS 648
	b) Conductor core	Electro grade copper or Die cast aluminium	IS 613 IS 4026
v)	Stator:		
	a) Lamination	Electrical sheet steel	IS 648
	b) Winding wire	Electro grade copper	IS 613
	1) Conductor		
	2) Insulation:		
	i) For water filled motors	PVC or polywrap copper conductor	IS 8783
	ii) For dry or encapsulated or oil filled or resin- filled motor	Super enamelled	Insulation details as covered in IS 13730 (Part 34)
vi)	Breather diaphragm	Nitrile rubber	
vii)	Thrust bearing	Vulcanized fibre <i>versus</i> chromium steel or graphite <i>versus</i> graphite or vulcanized fibre <i>versus</i> bronze	
viii)	Cable gland	Nitrile rubber	
ix)	Cable:		IS 694
	a) Conductor	Electro grade copper	
	b) Insulation	PVC or with polymer and /or sheathing	
x)	Stator casing	Grey cast iron or Carbon steel (sheet or pipe) or stainless steel sheet	IS 210, FG 200 IS 1570 (Part 5) Gr 20 Cr 13

NOTE — Use of the materials containing hazardous substance like lead beyond permissible portion shall be phased.

5.4 Recommendation for Selection of Submersible Cable

5.4.1 In case of PVC pipes a separate metallic cable from the motor to the control panel shall be provided or the top length held by the clamp of the discharge pipe shall be GI and earthing given as per 5.4.2.

5.4.2 If four-core cable is used, the fourth core not connected to the terminals can be used for earthing.

5.5 Finish of Bearings

For motors having journal bearings, the surface of the rotor shaft or that of the sleeves when provided at the bearing portion, shall have a surface roughness not higher than 0.75 microns Ra (*see* IS 3073).

5.6 Balancing of Rotor

The rotor shall be dynamically balanced as per grade given in 6.3 of IS 11723 (Part 1). PREFERRED VOLTAGE AND FREQUENCY

5.7 Preferred Voltage

The preferred rated voltage shall be 415 V for three-phase motors and 240 V for single-phase motors (*see* IS 12360).

6.1.1 Preferred Frequency

The preferred rated frequency shall be the standard frequency of 50 Hz.

5.8 Voltage and Frequency Variations

6.2.1 Category 'A'

The motors shall be capable of delivering rated output with,

- a) terminal voltage differing from this rated value by not more than ± 6 percent;
- b) frequency differing from its rated value by not more than ± 3 percent; and
- c) any combination of (a) and (b).

6.2.2 Category 'B'

The motor shall be capable of delivering rated output with;

- a) terminal voltage differing from this rated value by not more than +6 percent and –15 percent;
- b) frequency differing from its rated value by not more than ± 3 percent; and
- c) any combination of (a) and (b).

5.9 Preferred Output Ratings

The preferred output ratings, in kW, shall be:

- a) Three-phase motors: 0.75, 1.1, 1.5, 2.2, 3, 3.7, 4.5, 5.5, 7.5, 9.3, 11, 13, 15, 18.5 and 22
- b) Single-phase motors: 0.37, 0.55, 0.75, 1.1, 1.5 and 2.2

NOTES

1 For three-phase motor output ratings below and above specified the ratings may be permitted.

2 For single-phase motor output ratings below the ratings specified may be permitted.

5.10 Speed

The preferred speed shall correspond to 4 or 2-pole motors [1 500 or 3 000 rev/min (synchronous)].

6 DIMENSIONS AND TOLERANCES

6.1 Dimensions of Motors

Maximum overall diameter of bore hole submersible motors covered in this standards are 98 mm, 146 mm and 19.4 mm (*see also* Tables 2, 3, 4, 5, 6 and 7). For

19.6 mm (*see also* Tables 2, 3, 4, 5, 6 and 7).

NOTE — Motor with overall diameter of greater than 19.4 mm can be manufactured for 200 mm dia. and above, if required by the user.

Table 2 Values of Performance Characteristics for 2-Pole Three-Phase Submersible Motors — Water Filled (Suitable for Bore Size 100 mm and Maximum Outside Diameter of Motor 98 mm)
(Clauses 7.1 and 12.1)

Sl No.	Rated Output kW	Minimum Full Load Speed rpm	Maximum Full Load Current A	Minimum Starting Torque (in Terms of Percentage of Full Load Torque)	Nominal Efficiency		
					Percent	EL1	EL2
(1)	(2)	(3)	(4)	(5)	(6)		
i)	1.1	2 740	4.0	125	63	65.4	67.8
ii)	1.5	2 740	4.8	125	67	69.3	71.5
iii)	2.2	2 760	6.9	125	69	71.2	73.3
iv)	3.0	2 760	9.0	125	70	72.2	74.2
v)	3.7	2 780	10.6	125	70	72.2	74.2
vi)	4.5	2 780	12.6	125	71	73.1	75.1
vii)	5.5	2 790	15.5	125	72	74.1	76.0

NOTE — For motors of other output ratings the performance values shall be declared by the manufacturer.

Table 3 Values of Performance Characteristics for 2-Pole Three-Phase Submersible Motor — Water Filled (Suitable for Bore Size 150 mm and Maximum Outside Diameter of Motor 146 mm)
(Clauses 7.1 and 12.1)

Sl No.	Rated Output kW	Minimum Full Load Speed rpm	Maximum Full Load Current A	Minimum Starting Torque (in Terms of Percentage of Full Load Torque)	Nominal Efficiency		
					Percent	EL1	EL2
(1)	(2)	(3)	(4)	(5)	(6)		
i)	1.1	2 750	3.3	125	63.0	65.4	67.8
ii)	1.5	2 750	4.5	125	68.0	70.2	72.4
iii)	2.2	2 770	6.5	125	70.0	72.2	74.2
iv)	3.0	2 770	8.5	125	72.0	74.1	76.0
v)	3.7	2 790	10.0	125	73.0	75.0	76.9
vi)	4.5	2 790	12.0	125	75.0	76.9	78.7
vii)	5.5	2 810	14.5	125	77.0	78.8	80.5
viii)	7.5	2 810	19.5	125	78.0	79.8	81.4
ix)	9.3	2 830	25.0	125	79.0	80.7	82.3
x)	11.0	2 830	29.0	125	80.0	81.6	83.2
xi)	13.0	2 850	34.0	125	80.5	82.1	83.6
xii)	15.0	2 850	39.0	125	81.0	82.6	84.0

NOTE — For motors of other output ratings the performance values shall be declared by the manufacturer.

Table 3A Values of Performance Characteristics for 2-Pole Three-Phase Submersible Motor — Oil Filled (Suitable for Bore Size 150 mm and Maximum outside Diameter of Motor 146 mm)
(Clauses 7.1 and 12.1)

Sl No.	Rated Output kW	Minimum Full Load Speed rpm	Maximum Full Load Current A	Minimum Starting Torque (in Terms of Percentage of Full Load Torque)	Nominal Efficiency		
					Percent	EL1	EL2
(1)	(2)	(3)	(4)	(5)	(6)		
i)	2.2	2810	5.8	125	71	73.1	75.1
ii)	3.0	2810	7.8	125	73	75.0	76.9
iii)	3.7	2830	9.1	125	74.5	76.4	78.3
iv)	4.5	2830	11.1	125	76	77.9	79.6
v)	5.5	2850	13.8	125	77	78.8	80.5
vi)	7.5	2580	18	125	78.5	80.2	81.8
vii)	9.3	2870	23.4	125	79.5	81.2	82.7
viii)	11.0	2870	27.3	125	80.5	82.1	83.6
ix)	13.0	2870	32	125	81.5	83.0	84.5
x)	15.0	2880	36.7	125	82	83.5	84.9

NOTE — For motors of other output ratings the performance values shall be declared by the manufacturer.

Table 4 Values of Performance Characteristics for 2-Pole Three-Phase Submersible Motor — Water Filled (Suitable for Bore Size 200 mm and Maximum Outside Diameter of Motor 196 mm)

Sl No.	Rated Output kW	Minimum Full Load Speed rpm	Maximum Full Load Current A	Minimum Starting Torque (In Terms of Percentage of Full Load Torque)	Nominal Efficiency		
					Percent	EL1	EL2
(1)	(2)	(3)	(4)	(5)	(6)		
i)	3.0	2 780	8.5	125	76.0	77.9	79.6
ii)	3.7	2 790	10.0	125	77.0	78.8	80.5
iii)	4.5	2 800	12.0	125	78.0	79.8	81.4
iv)	5.5	2 810	14.5	125	79.0	80.7	82.3
v)	7.5	2 820	19.5	125	80.0	81.6	83.2
vi)	9.3	2 830	25.0	125	80.5	82.1	83.6
vii)	11.0	2 840	29.0	125	81.0	82.6	84.0
viii)	13.0	2 850	34.0	125	81.5	83.0	84.5
ix)	15.0	2 860	39.0	125	82.0	83.5	84.9
x)	18.5	2 860	48.0	125	82.0	83.5	84.9
xi)	22.0	2 870	57.0	125	82.5	84.0	85.3
xii)	26.0	2870	66	125	82.5	84.0	85.3
xiii)	30.0	2870	76	125	82.5	84.0	85.3
xiv)	37.0	2870	85	125	82.5	84.0	85.3
xv)	45.0	2870	100	125	82.5	84.0	85.3
xvi)	55.0	2870	120	125	82.5	84.0	85.3
xvii)	63.0	2870	135	125	82.5	84.0	85.3
xviii)	67.0	2870	144	125	82.5	84.0	85.3
xix)	75.0	2870	158	125	82.5	84.0	85.3
xii)	26.0	2870	66	125	82.5	84.0	85.3

NOTE — For motors of other output ratings the performance values shall be declared by the manufacturer.

Table 5 Values of Performance Characteristics for 2-Pole Single-Phase Submersible Motor — Water Filled (Suitable for Bore Size 100 mm and Maximum Outside Diameter of Motor 98 mm)
(Clauses 7.1 and 12.1)

Sl No.	Rated Output kW	Minimum Full Load Speed rpm	Maximum Full Load Current A	Nominal Efficiency		
				Percent	EL1	EL2
(1)	(2)	(3)	(4)	(5)		
i)	0.37	2 740	5.3	42.0	44.6	47.2
ii)	0.55	2 750	6.2	45.0	47.6	50.3
iii)	0.75	2 760	7.5	50.0	52.6	55.2
iv)	1.1	2 760	10.5	53.0	55.6	58.2
v)	1.5	2 770	13.8	55.0	57.6	60.1
vi)	2.2	2 770	19.8	60.0	62.5	64.9

NOTES

1 Minimum starting torque : 30 percent of full load torque.

2 For motors of other output ratings the performance values shall be declared by the manufacturer.

Table 6 Schedules of Tolerances
(Clauses 7.1, 12.1 and 17.2)

SI No. (1)	Item (2)	Tolerances (3)
<i>i)</i>	<i>Efficiency</i>	
	a) By summation of losses:	
	Motors up to 50 kW	Motors above 50 kW
	b) By input-output test	
<i>ii)</i>	<i>Losses</i>	
	-15 percent of $(1 - \eta)$	
	-10 percent of $(1 - \eta)$	
	-15 percent of $(1 - \eta)$	
	Total losses applicable to motors above 50 kW	+10 percent of the total losses declared
	NOTE — η = declared value of nominal efficiency	

Table 7 Values of Performance Characteristics for 2-Pole Single Phase Submersible Motor — Oil Filled
(Suitable for Bore Size 100 mm and Maximum Outside Diameter of Motor 98 mm)
(Clause 7.1)

SI No.	Rated Output kW (2)	Minimum Full Load Speed rpm (3)	Maximum Full Load Current A (4)	Nominal Efficiency Percent		
				EL1	EL2	EL3
(1)				(5)		
i)	0.37	2 780	4.1	50.5	53.1	55.7
ii)	0.55	2 780	5	52.0	54.6	57.2
iii)	0.75	2 790	6.7	56.5	59.1	61.6
iv)	1.1	2 790	9.5	59.0	61.5	64.0
v)	1.5	2 800	12.5	62.0	64.4	66.8
vi)	2.2	2 800	16	67.0	69.3	71.5

NOTES

1 Minimum starting torque 30 percent of full load torque.

2 For motors of other output ratings the performance values shall be declared by the manufacturers.

7.1.1 Dimension of Shafts of Submersible Motors for Borehole Pumps

Recommended dimensions for shafts of submersible motors for borehole pumps are given in Fig. 5 to 7.

7.2 Tolerances

7.2.1 For motors with anti-friction bearings, the accuracies of shaft extension runout, concentricity of mounting rabbet and face runout, if not otherwise specified, shall be of normal class given in Table 6 and Table 7 of IS 2223 for all sizes of submersible motors for boreholes 100 mm to 200 mm.

7.2.2 For motors with journal bearings, the face runout on the spigot and shaft run out shall not be more than 125 microns and eccentricity shall not be more than 100 microns. The method of measurement shall be as per Fig. 8 to 10.

8 TYPE OF DUTY

The motor shall be of continuous duty (Type S1) specified in IS 12824.

9 LIMITS OF TEMPERATURE RISE

The temperature rise of insulated windings of stator shall meet the requirements given in **19**.

10 OVERLOADS

The motors shall meet the requirements specified in **18**.

11 PERFORMANCE CHARACTERISTICS

The motors shall comply with the requirements given in **17**.

12 EFFICIENCY AND POWER FACTOR

12.1 Efficiency

The statement of efficiency at rated load of the motor shall be made by the manufacturer. The values for 2-pole motors shall not be inferior than those given in Tables 2, 3, 4, 5, 6 and 7. The values of 4-pole motors are under consideration.

NOTES

1 For determination of efficiency of three-phase submersible motors by summation of losses method as outlined in IS 4029, the stator copper losses I^2R shall be calculated using the value of resistance as at 50°C for motors wound with PVC / Polywrap insulation and 75°C for motors wound with enamelled copper wires.

2 For determination of efficiency of single-phase submersible motors by method as outlined in IS 7572.

12.2 Power Factor

If a statement of power factor of the motor is required, the purchaser shall specify at the time of enquiry. The

tolerances on the declared values shall be applicable in accordance with IS 7538, IS 325 or IS 14582 as applicable.

13 TERMINAL MARKINGS

The terminal markings or identification of lead wires shall be clearly given for proper connections to the supply system.

14 INFORMATION TO BE GIVEN WITH ENQUIRY AND ORDER

The following general information may also be furnished when enquiring for and ordering the submersible motor, in addition to the information given in Annex B of IS 325:

- a) Level of water above the submersible motor; and
- b) Length of the electric cable, which is required for the submersible motor.

The complete information to be given with enquiry and order is given at Annex B.

M8-4 STUDS AND NUTS MAT.
416 STAINLESS STEEL OR EQUIVALENT
CORROSION RESISTANT MATERIAL

SHAFT EXTENSION 416 STAINLESS
STEEL OR EQUIVALENT CORROSION
RESISTANT MATERIAL

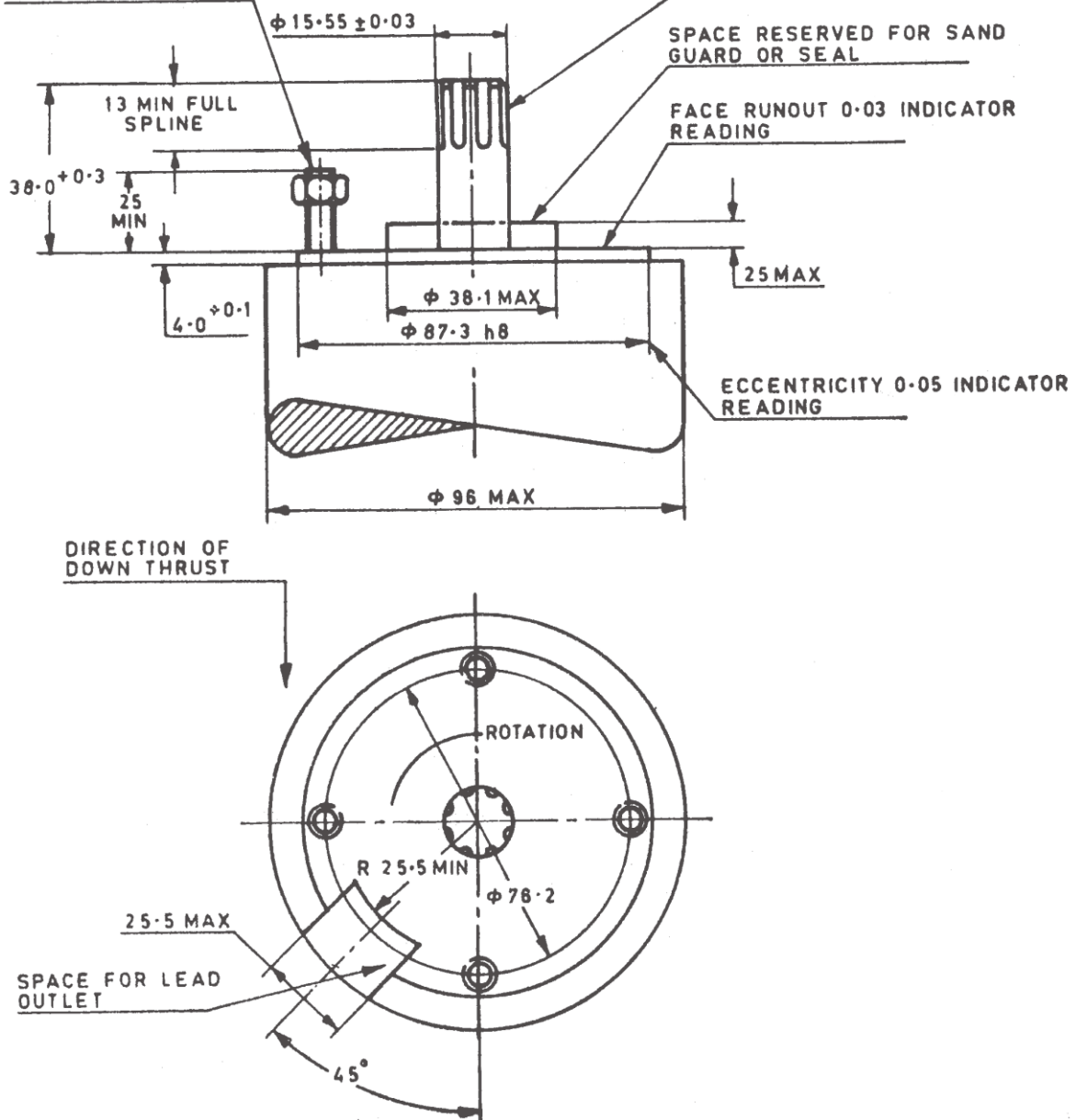

All dimensions in millimetres.

NOTES

- 1 Normal operating position of motors is vertical with shaft up.
- 2 For spline data (see Fig. 7).
- 3 Substitute measure dia (spline) as $15.6^{-0.00/-0.05}$ for $15.6^{-0.00/-0.03}$.

FIG. 5 END CONNECTIONS OF SUBMERSIBLE MOTOR FOR BORE HOLE PUMPS (100 mm BORE)

STANDARD MATRIC, 4 TAPPED HOLES
MAY BE USED THAT IS M12 HAVING
FULL THREAD DEPTH 19 mm MIN (BLIND
HOLES) AND FULL THREAD LENGTH
16 mm MIN (THROUGH HOLES)

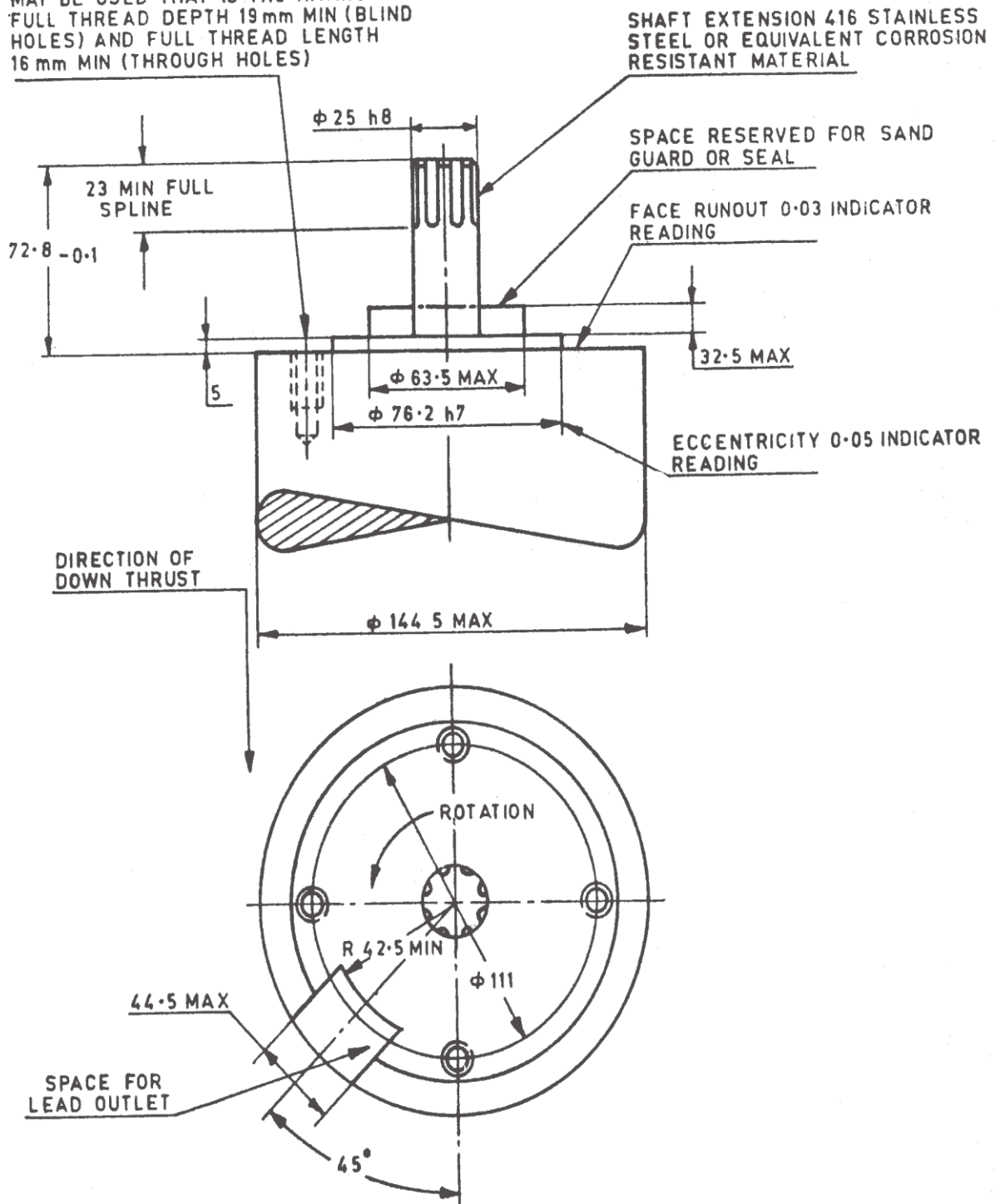

All dimensions in millimetres.

NOTES

- 1 Normal operating position of motors is vertical with shaft up.
- 2 For spline data (see Fig. 7).
- 3 Substitute measure dia (spline) as $25^{-0.007/0.05}$ for $25^{-0.001/0.03}$.

FIG. 6 END CONNECTIONS OF SUBMERSIBLE MOTOR FOR BORE HOLE PUMPS (150 mm BORE)

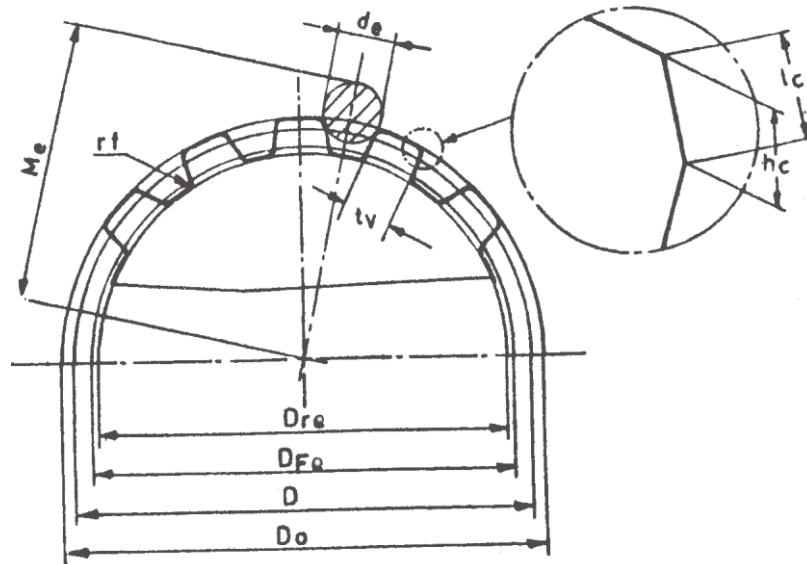

External Spline Data

All dimensions in millimetres.

Description	Motor Suitable for Bore	
	100 mm	150 mm
No. of teeth, N	14	15
Diametrical pitch, P	24/48	16/32
Pressure angle	30°	30°
Base diameter, D_b	12.83	20.62
Pitch diameter, D	14.80 ± 0.1	23.81 ± 0.1
Major diameter, D_o	- 0.00	-0.000
	15.60	25.00
	-0.05	-0.05
Form diameter, D_{Fe}	13.70 ± 0.1	22.10 ± 0.1
Minor diameter, D_{Fe}	13.3 ± 0.1	20.53 ± 0.1
Effective tooth thickness, t_v	1.62 ± 0.03	2.46 ± 0.03
Minimum measurement over pins, M_e	17.83 ± 0.02	28.25 ± 0.02
Pin diameter, d_e	2.03	3.05
Chamfer height, h_c	0.15	0.25
Chamfer height, l_c	0.2	0.3
Spline length, L_{Min} (Effective)	13	23
Fillet radius, r_f	0.1	0.15
Maximum run-out	0.025	0.025
Maximum total indexing	0.033	0.038
Maximum involute flank form error	0.012	0.02
Maximum flank deflection distortion	0.008	0.013
Type of spline	Involute sided	Involute sided
Tolerance class	5	5

NOTES

- 1 Type of Spline : Involute
- 2 Type of Fit : Fillet Root Side Fit
- 3 Tolerance Class : 5
- 4 All dimensions in millimetres except diametrial pitch.

FIG. 7 SPLINE FOR SHAFT EXTENSION FOR SUBMERSIBLE MOTOR

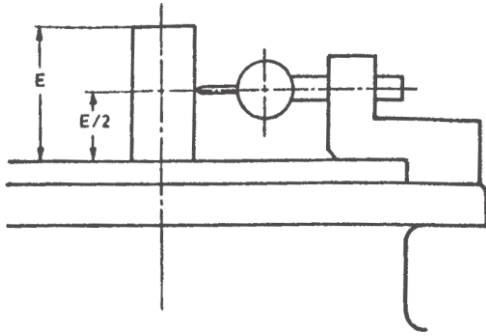

FIG. 8 MEASUREMENT OF SHAFT EXTENSION RUN-OUT

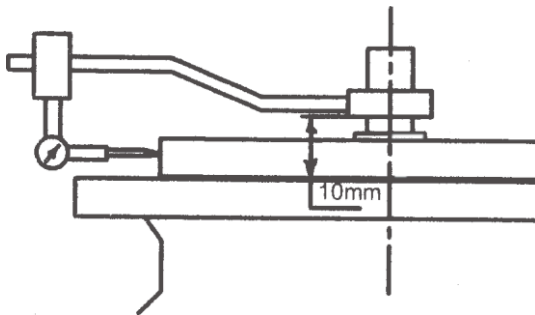

FIG. 9 MEASUREMENT OF CONCENTRICITY OF MOUNTING SPIGOT AND SHAFT

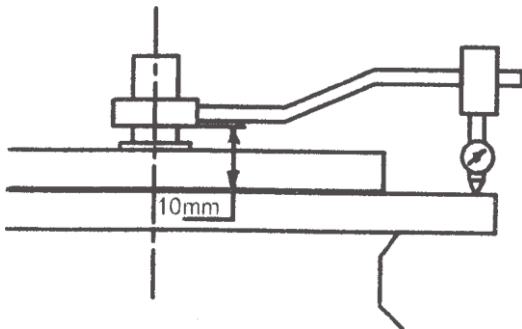

FIG. 10 MEASUREMENT OF FACE RUNOUT

15 RATING PLATE

15.1 The motor shall have the rating plate giving the following information:

- a) Reference to this Indian Standards, that is IS 9283;
- b) Induction motor;
- c) Name of the manufacturer;
- d) Manufacturer's serial number;
- e) Type of duty;
- f) Frequency, in Hz;
- g) Number of phases;
- h) Rated output, in kW;
- j) Rated voltage and winding connections;

- k) Current, approximate, at rated output, in A;
- m) Speed in at rated output, in rev/min;
- n) Nominal efficiency, in percent; and
- p) Category of motor and bore size, in mm.

15.2 In addition, the manufacturer's serial number shall be punched at a convenient place for easy identification.

15.3 BIS Certification Marking

The motor may also be marked with BIS Standard Mark.

15.3.1 The use of the Standard Mark is governed by the provision of the *Bureau of Indian Standards Act, 1986* and the Rules and Regulations made thereunder. The details of condition under which a licence for the use of the Standard Mark may be granted to manufacturers or producers may be obtained from the Bureau of Indian Standards.

16 CLASSIFICATIONS OF TESTS

16.1 Type Tests

The following shall constitute the type tests:

- a) Insulation resistance test (both before and after the high voltage test);
- b) High voltage test;
- c) Measurement of stator resistance;
- d) No load running of motor and reading of voltage, current, power input and speed;
- e) Reduced voltage running up test at no load to check the ability of the motor to run up to full speed on no load with 60 percent of the rated voltage applied to the motor for three-phase motors and 75 percent of the rated voltage applied to the motor for single-phase motors;
- f) Locked rotor readings of voltage, current, power input and torque of motors;

NOTE — This test may be made at a reduced voltage, when a current at least equivalent to full load current is being taken by the motor.
- g) Full load reading of voltage, current, power input and slip;

NOTE — Pump may be used as a loading device.
- h) Performance characteristics;
- j) Temperature rise test at rated voltage;
- k) Temperature rise test at reduced voltage;
- m) Momentary over-load test (as per agreement between the manufacturer and the purchaser); and
- n) Leakage current test at rated voltage at no load.

NOTE — The recommended proforma for preparing a type test certificate is given in Annex C.

16.2 Routine Test

The following shall constitute the routine test:

- a) Insulation resistance test (before high voltage test only);
- b) High voltage test;
- c) No load running of motor and reading of current, voltage, power and speed;
- d) Locked rotor reading of voltage, current and power input; and
- e) Reduced voltage running up test at no load to check the ability of the motor to run up to full speed on no load with 60 percent of the rated voltage applied to the motor for three-phase motors and 75 percent of the rated voltage applied to the motor for single-phase motors.

NOTE — This test may be made at reduced voltage, when a current at least equivalent to full load current is being taken by the motor.

17 PERFORMANCE VALUES

17.1 Minimum full load speed, maximum full load current, minimum starting torque, nominal efficiency for 2 pole submersible motors of single-phase and three-phase at rated voltage of 240 V and 415 V respectively and suitable for bores of 100 mm, 150 mm and 200 mm shall be in accordance with Tables 2, 3, 4, and 5.

NOTES

- 1 For three-phase motors, the value of the full load current shall be taken as the average value of the currents measured in the three phase.
- 2 For motor having rated voltage other than 415V for three-phase and 240V for single-phase, values given in Tables 2, 3, 4 and 5 shall be applicable except for value of maximum full load current, which would be changed, in the inverse proportion of the voltage.
- 2 In case the manufacturer declares superior nominal values of performance than specified in Tables 2, 3, 4, and 5 declared values shall be subject to verification. The observed values of the performance characteristics obtained from the test results shall confirm to the declared values of the manufacturer within the tolerances specified in Table 6.
- 3 Performance values for other motors not specified in this standard (Irrespective of bore sizes, number of poles, and number of phases) shall be declared by the manufacturer.
- 4 Speed is to be corrected for 50 Hz.

17.2 Tolerances

Unless otherwise specified, tolerance on performance shall be in accordance with Table 6. Where a tolerance is stated in the other direction, is considered unimportant.

18 OVERLOAD TEST

18.1 Momentary Excess Torque

The motor shall, whatever their type of construction, be capable of with standing for 10 s without stalling or abrupt change in speed (under gradual increase of torque) an excess torque of 60 percent of the rated torque the voltage and frequency being maintained at their rated value.

18.2 Sustained Overloads

Motors rated in accordance with this standard are not capable of carrying sustained overload.

19 TEMPERATURE RISE TEST

19.1 The temperature rise test of the motor at rated voltage and supply frequency shall be carried out with the motor coupled to a suitable pump for the full load current and the set run continuously for 1 h till steady state temperature is achieved. The set is stopped and the temperature rise of the stator winding computed by the resistance method shall not exceed 35°C at rated voltage and 45°C at 85 percent of the rated voltage when the set is run for 1 h soon after the test at rated voltage. During the test, the temperature of the cooling water surrounding the motor may not exceed 45°C.

NOTE — Temperature rise test at 85 percent of rated voltage is not applicable for category 'A' motor.

19.2 Determination of Temperature Rise of Winding by Resistance Method

The temperature rise ($t_2 - t_1$) may be obtained from the ratio of the resistance by the formula:

$$\frac{t_2 + 235}{t_1 + 235} = \frac{R_2}{R_1}$$

Where

t_2 = temperature of the winding at the end of the test in °C;

R_2 = resistance of the winding at the end of the test measured within 30s after shut down;

t_1 = temperature of the winding (cold) at the moment of the initial resistance measurement, in °C; and

R_1 = initial resistance of the winding (cold).

For practical purpose the following alternative formula may be found convenient:

Where

$$t_2 - t_1 = \frac{R_2 - R_1}{R_1} (235 + t_1) + (t_1 - t_a)$$

t_a = temperature of cooling medium at the end of the test, in °C.

20 HIGH VOLTAGE TEST

20.1 The high voltage test shall be applied between the windings and the frame only to a new and completed motor with all of its parts in place filled with water.

The test shall be carried out at the conclusion of the temperature rise test of the motor where such a test is carried out.

20.2 The test voltage shall be of the supply frequency and shall be as near as possible to sine wave form. The test shall be commenced at a voltage of not more than one half of the full test voltage. The voltage shall then be increased to the full value steadily or in the steps of not more than 5 percent of the full value, the time allowed for the increase of the voltage from half to full value being not less than 10 s. The full test voltage of 1 500 V shall be maintained for 30 s.

20.3 During the routine testing of motors of rated output up to and including 5.5 kW, the 30 s test may be replaced by a test of approximately 5 s at the test voltage given in **20.2**, following the same procedure.

20.4 Since the test is already made on the windings for acceptance shall, as far as possible, not be repeated. If however a second test is made at the laboratory or at the special request of the purchaser, the test voltage shall be 80 percent of the voltage (1 200 V) given in **20.2**.

NOTE — The HV tester shall have adequate capacity to carry the leakage current of the motor.

21 INSULATION RESISTANCE TEST

The insulation resistance when the high voltage test is applied shall be not less than 5 m Λ . The insulation resistance shall be measured with a dc voltage of 500 V applied for a sufficient time for the reading of the indicator to become practically steady, such voltage being taken from an independent source or generated in the measuring instrument.

22 SPEED

The speed measurement may be conveniently taken by means of a slip coil or any other suitable method.

23 LEAKAGE CURRENT TEST

The maximum leakage current value shall not be more than 50 mA at rated voltage at no load. The motor shall be placed on either a rubber mat or a wooden base or any other insulated base. A voltage equal to the rated voltage shall be applied to any supply line and accessible outside metal parts of the motor. The resistance of the test circuit shall be $2\,000 \pm 50 \Lambda$.

NOTE — For safety purpose it shall be ensured during installation that the earthing is capable of taking care of leakage current.

ANNEX A

(Clause 2)

LIST OF REFERRED INDIAN STANDARDS

<i>IS No.</i>	<i>Title</i>	<i>IS No.</i>	<i>Title</i>
210 : 2009	Grey iron castings — Specification (<i>fourth revision</i>)	1873 : 1961	Specification for thinner, anti - chill for cellulose nitrate based paints, dopes and lacquers for aircrafts
318 : 1981	Specification for leaded tin bronze ingots and castings (<i>second revision</i>)	1885 (Part 35) : 1993	Electrotechnical vocabulary: Part 35 Rotating machines (<i>first revision</i>)
12615: 2018	Line operated three phase AC motors (IE Code) "Efficiency classes and performance specification" (Third Revision)	2223 : 1983	Dimensions of flange mounted ac induction motors (<i>first revision</i>)
613 : 2000	Copper rods and bars for electrical purposes —Specification (<i>third revision</i>)	3043 : 2018 3073 : 1967	Code of practice for earthing (<i>Second revision</i>) Assessment of surface roughness
648 : 2006	Cold rolled non-oriented electrical steel sheet and strip — Fully processed type — Specification (<i>fifth revision</i>)	4026 : 1987 4029 : 2010	Aluminium ingots billets and wire bars (EC grade) Guide for testing three phase induction motors (First Revision)
694 : 2010	Polyvinyl chloride insulated unsheathed and sheathed cables/cords with rigid and flexible conductor for rated voltages up to and including 450/750 v (Fourth Revision)	7538 : 1996	Three-phase squirrel cage induction motors for centrifugal pumps for agricultural applications (<i>first revision</i>)
1570 (Part 5) : 1985	Schedules for wrought steels: Part 5 Stainless and heat resisting steels (<i>second revision</i>)	7572 : 1974 12824 : 1989	Guide for testing single-phase ac and universal motors Type of duty and classes of rating assigned to rotating electrical machines
8034 : 2018	Submersible pumpsets - Specification (Third Revision)PVC insulated	13730 (Part 34): 2000	Specifications for particular types of 2000 winding wires: Part 34 Polyester enamelled round copper wire Class 130 (<i>first revision</i>)
8783 : 1995	winding wires for submersible motors (<i>first revision</i>)		Openwell submersible pumpsets - Specification (First Revision)
10804 (Part 2) : 2018	Recommended pumping systems for agricultural purposes: Part 2 submersible pump sets (Third Revision)	14220 : 2018	
11723 (Part 1) : 1992	Mechanical vibration — Balance quality requirements of rigid rotors: Part 1 Determination of permissible residual unbalance	14582 : 2021	Single-phase small ac electric motors for centrifugal pumps for agricultural applications
12360 : 1988	Voltage bands for electrical installations including preferred voltages and frequency		

ANNEX B
(*Clause 14*)

INFORMATION TO BE GIVEN WITH ENQUIRY AND ORDER

B-1 Following information to be provided with enquiry and order:

1. Site and operating conditions.
2. Reference to this standard that is IS 9283.
3. Diameter of the bore.
4. Level of water above the submersible motor.
5. Length of cable, which is required for the submersible motor.
6. Type of duty.
7. Frequency, in Hz.
8. Number of phases.
9. Mechanical output, in kW.
10. Rated voltage and permitted variation.
11. Speed, in rev/min, approximate, at the rated output.
12. If a motor is required to operate between various limits of voltage, current, frequency or speed, the corresponding value of the voltage, current, frequency or speed respectively.
13. System of earthing, if any, to be adopted.
14. Particulars of tests required and where they are to be carried out.
15. Method of starting to be employed.

ANNEX C
(Clause 16.1)

FORM FOR TEST REPORT OF MOTORS FOR SUBMERSIBLE PUMPSETS

Name and address of the manufacturer _____
 Purchaser _____ Certificate No. _____
 Purchase order No. _____ Order acceptance No. _____

Name Plate Data

Motor SI No. _____	Voltage _____ V
Output _____ kW	Frequency _____ Hz
Speed _____ rpm	Current _____ A
Data Type _____	Bore Well Size _____ mm

Test Characteristics

Loading Condition	Volts V	Amps A	Watts kW	Load	Slip Percentage	Power Factor	Efficiency
No Load							
Full Load							

Temperature Rise Test

Condition of Test			Watts	Calculated		Temperature
Hours Run H	Line Voltage V	Line Current A	Input kW	Output kW	Rise °C	

At rated Volts
 At 85 percent
 of the rated
 Volts

Breakaway Torque and Starting Current

Breakaway torque (Locked rotor) with Volts applied	V _____ _____ kg.m	Breakaway starting current and power input (Locked rotor) with Volts applied	} V _____ W _____ A _____ _____ kg.m
--	-----------------------	--	---

Insulation resistance test _____	Megaohm
High voltage test _____	Volt for 30 s
Resistance of winding _____	Ohm
Momentary overload _____	15 s

Test conducted on motor No. _____
 Tested by: _____ On: _____ Date: _____

Approved By _____

