

भारतीय मानक
Indian Standard

IS 14476 (Part 1 to 9) : 2024

जलकूपों का पम्पिंग परीक्षण — रीति संहिता
(पहला पुनरीक्षण)

**Pumping Test of Water Wells —
Code of Practice**
(*First Revision*)

ICS 07.060; 13.060.10

© BIS 2024



भारतीय मानक ब्यूरो
BUREAU OF INDIAN STANDARDS
मानक भवन, 9 बहादुर शाह ज़फर मार्ग, नई दिल्ली - 110002
MANAK BHAVAN, 9 BAHADUR SHAH ZAFAR MARG
NEW DELHI - 110002
www.bis.gov.in www.standardsbis.in

December 2024

Price Group 14

FOREWORD

This Indian Standard (Part 1 to 9) (First Revision) was adopted by the Bureau of Indian Standards, after the draft finalized by the Ground Water and Related Investigations Sectional Committee had been approved by the Water Resources Division Council.

The increasing demand of water makes it vital that water resources are used efficiently and this, in turn, adds great importance to reliable quantitative estimates of ground water resources. At present, the pumping test is the most reliable way of evaluating the hydraulic behavior of wells and aquifers. The development of ground water resources without adequate pumping test data is a speculative operation which may have unforeseen consequences.

Pumping tests are normally carried out to obtain data with which to:

- a) Assess the hydraulic behavior of a well and so determine its ability to yield water, predict its performance under different pumping regimes, select most suitable pumping plant for long term use and give some estimate of probable pumping costs;
- b) Determine the hydraulic properties of the aquifer or aquifers which yield water to the well; these properties include the transmissivity and related hydraulic conductivities, storage coefficient and the presence, type and distance of any hydraulic boundaries; and
- c) Determine the effects of pumping upon neighboring wells, water courses, or spring discharges.

In addition, a pumping test also provides a good opportunity to obtain information on water quality and its variation with time and discharge.

For the successful execution of a pumping test, it is imperative that all stages leading up to it as well as post test operations, are well planned and all conceivable contingencies are taken care of.

This code of practice lays down the factors which need to be considered and the measurements which need to be made while designing and performing a pumping test. However, there can be no such thing as a 'standard' pumping test because of the great diversity of objectives, aquifers, ground water, conditions and available technology. This code of practice, therefore, provides a set of guidelines for field practice, with an indication of how they may be varied to take account of particular local conditions. The code deals with the usual types of pumping tests in which water is extracted from the well. Some guidance has also been provided on slug tests and packer tests.

Interpretation of data collected has been referred to in this code with a view to lay down broad guidelines for the same. Guidelines have also been provided for well development by commonly used procedures.

The following changes have been incorporated in this revision:

- a) New clause "Terminology" has been introduced in Part 1 General;
- b) Number and location of purpose-drilled observation wells has been modified in Part3/Sec 3 Observation wells;
- c) Radioisotopes have been included in Part 4 : Pre-test observation; and
- d) In Part 5 : Pumping test, observations to be made for "Stream flow determination" has been added.

The composition of the Committee responsible for formulation of this standard is given in [Annex B](#).

As the pumping test involves a series of interlinked but distinct operation, this code of practice has been formulated in various parts and sections as given below:

- Part 1 General
- Part 2 Hydrogeological considerations
- Part 3 Pretest planning, Section 1 General aspects

(Continued on third cover)

*Indian Standard***PUMPING TEST OF WATER WELLS — CODE OF PRACTICE****PART 1 GENERAL***(First Revision)***1 SCOPE**

This standard (Part 1) lays down the general aspects to be kept in mind during the planning and execution of a pumping test.

2 TERMINOLOGY

For the purposes of this document, the following definitions shall apply.

2.1 Abstraction — Removal of water from a borehole or well.

2.2 Access Tube — Pipe inserted into a well to permit installation of instruments, and safeguarding them from touching or becoming entangled with the pump or other equipment in the well.

2.3 Aquifer — Lithological unit, group of lithological units, or part of a lithological unit containing sufficient saturated permeable material to yield significant quantities of water to wells, boreholes or springs.

2.4 Aquifer Loss — Head loss at a pumped or overflowing well associated with ground water flow through the aquifer to the well face.

2.5 Aquifer Properties — Properties of an aquifer that determine its hydraulic behavior and its response to abstraction.

2.6 Borehole — A hole, usually vertical, bored to determine ground conditions, for extraction of water or measurement of ground water level.

2.7 Casing — Tubular retaining structure, which is installed in a drilled borehole or excavated well, to maintain the borehole opening.

NOTE — Plain casing prevents the entry of water.

2.8 Column Pipe — Part of the rising main within the well.

2.9 Cone of Depression — That portion of the potentiometric surface that is perceptibly lowered as a result of abstraction of groundwater from a well.

2.10 Confining Bed — Bed or body of impermeable material stratigraphically adjacent to an aquifer and

restricting or reducing natural flow of groundwater to or from the aquifer.

2.11 Discharge — Volumetric flow rate.

2.12 Drawdown — Reduction in static head within the aquifer resulting from abstraction.

2.13 Filter Pack — Granular material introduced into a borehole between the aquifer and a screen or perforated lining to prevent or control the movement of particles from the aquifer into the well.

2.14 Steady Flow — Flow in which parameters such as velocity, pressure, density and temperature do not vary sufficiently with time to affect the required accuracy of measurement.

2.15 Uniform Flow — Flow in which the magnitude and direction of flow at a given moment are constant with respect to distance.

2.16 Foot Valve — Non-return valve fitted at the bottom of a suction pipe of a pump.

2.17 Groundwater — Water within the saturated zone.

2.18 Hydraulic Conductivity — Volume of water at the existing kinematic viscosity that will move in unit time under a unit hydraulic gradient through a unit area measured perpendicular to the direction of flow.

NOTE — This definition assumes an isotropic medium in which the pores are completely filled with water.

2.19 Hydraulic Gradient — Change in static head per unit of distance in a given direction.

2.20 Hydrogeology — Study of subsurface water in its geological context.

2.21 Impermeable Material — Material that does not permit water to move through it at perceptible rates under the hydraulic gradients normally present.

2.22 Incompetent Stratum — Stratum unable to stand without support.

2.23 Isotropic — Having the same properties in all directions.

2.24 Lining — Tube or wall used to support the sides of a well, and sometimes to prevent the entry of water.

2.25 Lining Tube — Preformed tube used as the lining for a well.

NOTE — See also casing (2.7) and screen (2.39).

2.26 Lithology — Physical character and mineralogical composition that give rise to the appearance and properties of a rock.

2.27 Observation Well — Well used for observing groundwater head or quality.

2.28 Overflowing Well — Well from which groundwater is discharged at the ground surface without the aid of pumping.

NOTE — A deprecated term for this type of well is an artesian well.

2.29 Permeability — Characteristic of a material that determines the rate at which fluids pass through it under the influence of differential pressure.

2.30 Permeable Material — Material that permits water to move through it at perceptible rates under the hydraulic gradients normally present.

2.31 Phreatic Surface — Upper boundary of an unconfined groundwater body, at which the water pressure is equal to atmospheric.

2.32 Potentiometric Surface — Surface that represents the static head of groundwater.

2.33 Radius of Influence — Radius of the cone of depression.

2.34 Rest Water Level — Water level in the pumped well observed under equilibrium conditions when the pump is off.

2.35 Rising Main — Pipe carrying water from within a well to a point of discharge.

2.36 Rock — Natural mass of one or more minerals that may be consolidated or loose (excluding top soil).

2.37 Running Plot — Graph of a variable against elapsed time continually updated as measurements are taken.

2.38 Saturated Zone — The part of the earthen material, normally beneath the water table, in which all voids are filled with water.

2.39 Screen — Type of lining tube, with apertures designed to permit the flow of water into a well while preventing the entry of aquifer or filter pack material.

2.40 Slurry — Mixture of fluid and rock fragments formed when drilling or developing a borehole.

2.41 Specific Capacity — Rate of discharge of water from a well divided by the drawdown within the well.

2.42 Specific Yield — Ratio of the volume of water which can be drained by gravity from an initially saturated porous medium to the total volume of the porous medium.

2.43 Static Head — Height, relative to an arbitrary reference level, of a column of water that can be supported by the static pressure at a given point.

2.44 Storage Coefficient — Volume of water an aquifer releases from storage or takes into storage per unit surface area of the aquifer per unit change of head.

2.45 Transmissivity — Rate at which water of the prevailing kinematic viscosity is transmitted through a unit width of the saturated aquifer under a unit hydraulic gradient.

2.46 Unconsolidated Rock — Rock that lacks natural cementation.

2.47 Unsaturated Zone — The part of the earthen material between the land surface and the water table.

2.48 Water Table — Surface of the saturated zone at which the water pressure is atmospheric.

2.49 Well — Hole sunk into the ground for abstraction of water or for observation purposes.

2.50 Well Bore Storage — Volume of water released from within the well itself during a decline in head.

2.51 Well Development — Physical and chemical treatment of a well to achieve minimum resistance to movement of water between well and aquifer.

2.52 Well Efficiency — Measure of the performance of a production well.

2.53 Well Loss — Head loss resulting from flow of groundwater across the well face, including any part of the aquifer affected by drilling, and any filter pack or lining tube, into the well and up or down the well to the pump.

3 GENERAL

3.1 Groundwater Flow

The steady flow of groundwater through the saturated zone of an aquifer is described by Darcy's law. Assuming laminar flow condition, this can be written as:

$$Q = KA \frac{h_1 - h_2}{l} \quad \dots (1)$$

where

Q = rate of flow of water (in m³/day);

K = hydraulic conductivity of the aquifer (in m/day);

A = total cross-sectional area through which the flow is taking place (in m²);

h_1 and h_2 = hydraulic heads (in m of water) at the two points between which flow is occurring; and

l = distance between these two points (in m).

The hydraulic head at any point is the height, above some reference level to which the water would rise in an open-topped tube or manometer inserted into

the aquifer at that point. Hydraulic head is thus a measure of the potential energy of the water; groundwater flows from places where it has high energy to places where it has low energy, that is, from high heads to low heads.

In the case of an aquifer, observation wells give an indication of the head in the aquifer at that location (see Fig. 1 and Fig. 2). Only exceptionally, such as in deep wells where temperature change occurs, or in coastal aquifers with salinity variations, is the density of the water column not constant. Fig. 3 shows that in such exceptional cases it is important to measure head changes in terms of head of liquid in the aquifer rather than in terms of changes of level of the liquid in the well. It may be preferable to measure head changes, such as drawdown, by means of a pressure transducer suspended in the well opposite the aquifer. There may also be differences in layered aquifers, where water may be at slightly different heads in the various layers and a well open at all these layers will cause complications by permitting vertical flow of water between the various layers in an attempt to equalize the heads. In the majority of cases, however, the term hydraulic head or head as used in this code of practice can be regarded as synonymous with water level in a well.

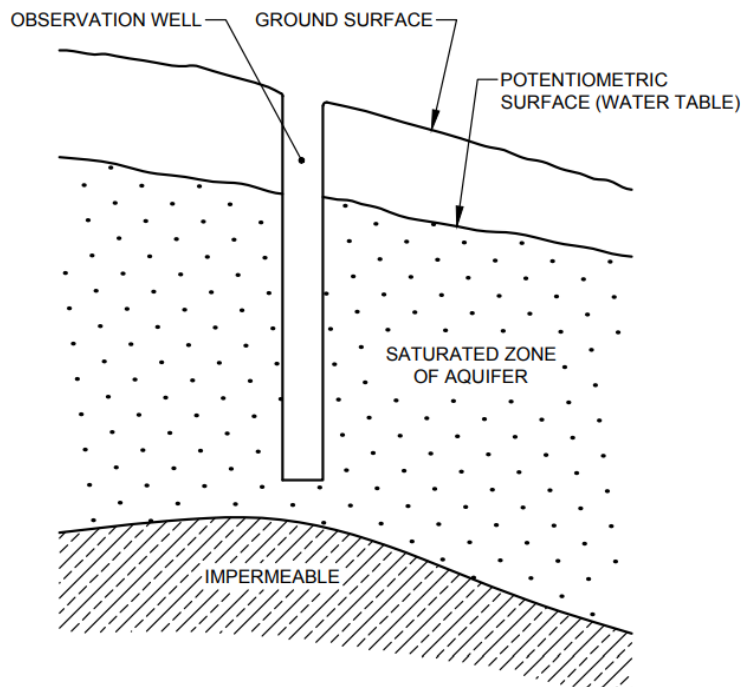

FIG. 1 OBSERVATION WELL IN AN UNCONFINED AQUIFER

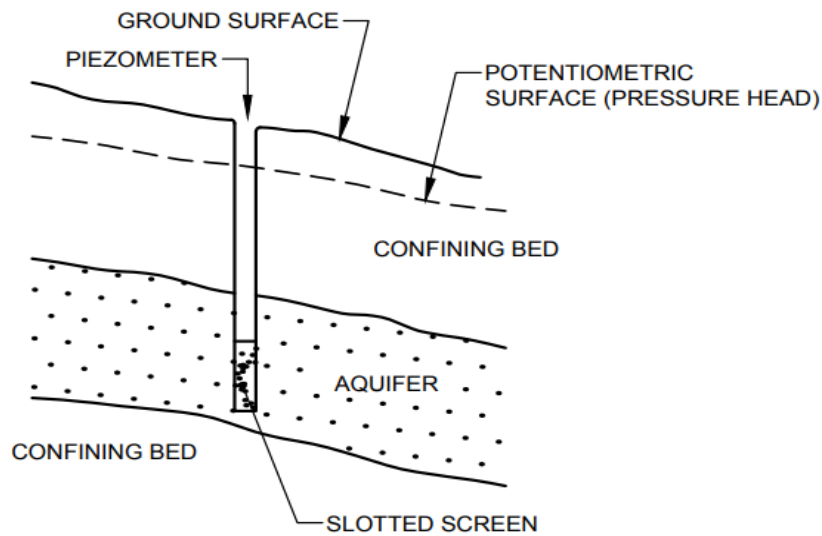

FIG. 2 PIEZOMETER IN A CONFINED AQUIFER

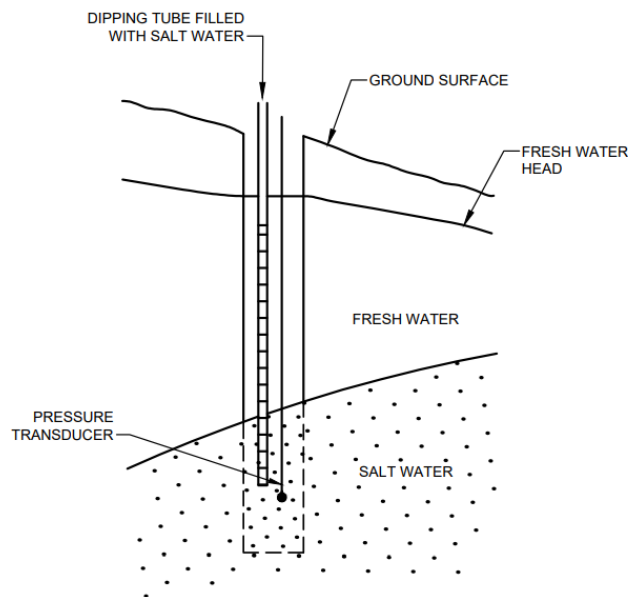

FIG. 3 OBSERVATION WELL PENETRATING SALT WATER

In equation (1), $h_1 - h_2$ represents the magnitude of the average rate of change of head or water level with distance and is thus the average hydraulic gradient. The other term in equation (1), the hydraulic conductivity K , is a measure of the ease with which water can flow through unit cross-sectional area of the aquifer under a given hydraulic gradient. It depends on the pores or other openings in the aquifer and on the viscosity of the

water; warm pure water is less viscous than cold or saline water and will, therefore, flow more easily.

Another term sometimes used in groundwater tests is specific discharge, q (in m/day). This is defined as:

$$q = Q/A \quad \dots (2)$$

Where Q and A are as in equation (1).

The factors that decide whether a rock unit is economic as an aquifer include not only the hydraulic conductivity but also the thickness. The transmissivity expresses the combination of effective thickness and hydraulic conductivity in a homogeneous aquifer, it is the product of the hydraulic conductivity and the saturated thickness. In aquifers consisting of layers of material with different hydraulic conductivities, the transmissivity of the aquifer is the sum of the transmissivity contributions of the individual layers, and it may be misleading in such a case to divide the total transmissivity by the saturated thickness to derive an 'average' hydraulic conductivity. It should also be remembered that most pumping test interpretation formulae assume that the aquifer is homogeneous and isotropic, or that simple layering or anisotropy is present and the application of such formulae to the more complicated situations present in most aquifers, although common, is not strictly valid.

3.2 Test Objectives

There are two test objectives, an understanding of the characteristics of the well and those of the aquifer. A test may be performed to serve or all of the main objectives. If they are satisfied it may be

said that the hydraulic regime of the well and aquifer has been evaluated. However, it should be understood that other information, particularly about other factors affecting recharge, is required to predict the long-term effects of abstraction.

It should be recognized that there are inherent difficulties involved in carrying out a pumping test, an example being the many physical measurements. In part these arise from the tendency of the measuring process or equipment to change the quantity being measured. For example, the drilling of boreholes to investigate the hydraulic regime of an aquifer may disturb that hydraulic regime by providing vertical communication between aquifer levels containing water at different heads. A second difficulty involves sampling. Only rarely will a cone of depression be circular and symmetrical. The relatively few observation boreholes which are usually available, in effect provide a limited number of sampling points to determine the form of the cone. It is important that these limitations and difficulties are kept clearly in mind when designing and analyzing a pumping test and, in particular, when using the results. Fig. 4 indicates the normal sequence of events in a pumping test.

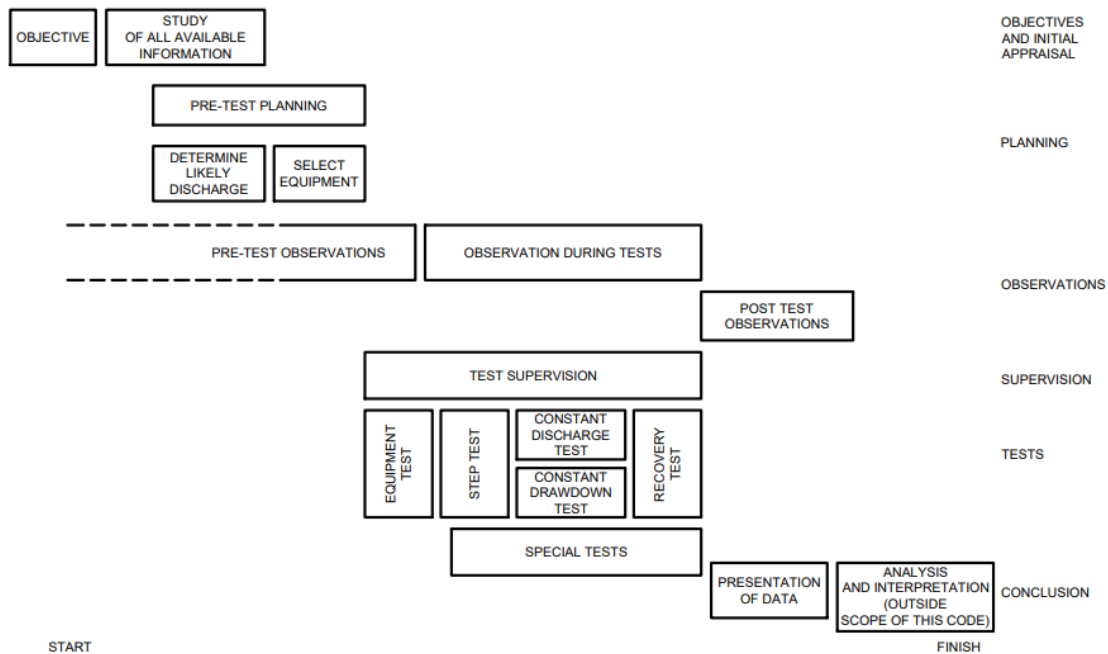

FIG. 4 TYPICAL PUMPING TEST PROCEDURE

Indian Standard

PUMPING TEST OF WATER WELLS — CODE OF PRACTICE

PART 2 HYDROLOGICAL CONSIDERATION

(*First Revision*)

1 SCOPE

1.1 This standard (Part 2) lays down the hydrogeological aspects to be kept in mind at or around the proposed site for a pumping test.

2 GENERAL

Before a pumping test is planned a full assessment of the hydrogeological conditions at and around test site should be carried out. Relevant information should be obtained from the offices of the responsible statutory bodies. A survey of existing wells is necessary and, in areas where the hydrogeological data are inadequate, it may be desirable to expand these by a field survey.

Because of the wide range of circumstances in which pumping tests might be contemplated and the probability that the aquifer is partly and perhaps nearly fully developed already, a search for and analysis of, existing operational boreholes and test data and associated surface water levels and flows should be considered as prerequisites to such tests.

3 AQUIFER RESPONSE CHARACTERISTICS

Two parameters define the quantitative hydrogeological properties of an aquifer, namely hydraulic conductivity and storage. Hydraulic conductivity is concerned with the ability of an aquifer to permit groundwater flow under a hydraulic gradient. Storage concerns the volume of water available within the aquifer and subsequently released when water levels are depressed around a discharging well. Together these two parameters can be taken to control the response time for pumping effects in an aquifer. With a low hydraulic conductivity and a large storage coefficient the radius of influence will increase slowly. An aquifer with a high hydraulic conductivity and a small storage coefficient would exhibit a rapid increase in the growth of the radius of influence.

A consideration of the aquifer response time is necessary when locating sites for observation wells.

4 GROUNDWATER CONDITIONS

The storage coefficient in a confined aquifer may be at least 100 times less than specified yield in the same aquifer in an unconfined state. This reduction

is reflected in a much more rapid aquifer response time. When the confining bed is not wholly impermeable the storage coefficient varies between the values for totally unconfined and totally confined values and the aquifer response time will vary accordingly.

The presence of overlying impermeable strata does not necessarily imply a confined aquifer. The presence of an unsaturated zone beneath an impermeable stratum may permit the aquifer to demonstrate an unconfined response.

It is possible for confined and unconfined conditions to occur in different parts of the same aquifer, or in the same part of the aquifer, as a result of seasonal or other movements of the potentiometric surface. [Annex A](#) gives more details about ground water conditions and aquifer states.

5 MULTI-LAYERED AQUIFERS

Most aquifers are comprised of sedimentary strata and these are deposited as a series of superimposed layers. Successive layers could have different lithological characteristics from the adjacent layers and consequently the hydraulic conductivity in the horizontal plane tends to be greater than that in the vertical plane. In extreme cases intervening layers may be impermeable resulting in a multi-layered aquifer. Wells penetrating such an aquifer may intersect an unconfined layer near the surface and one or more confined layers at depth. Failure to recognize this possibility may lead to inadequate monitoring of groundwater levels and to misleading data being obtained in a pumping test.

6 BOUNDARY CONDITIONS

Barrier boundaries are normally presented by geological discontinuities caused by faulting-out of the aquifer or by the aquifer itself having a rapid decrease in thickness or saturated thickness. Occasionally aquifers show a rapid, lateral, lithological change with a consequent severe reduction in the aquifer properties. Deep channels scoured in an aquifer and later filled with impermeable deposits may also form barriers. Barrier boundaries have the effect of increasing the drawdown. The pumping of another well in the same aquifer will have the same effect as a boundary, if the cones of influence of the two wells intersect.

Recharge boundaries occur when water other than from groundwater storage effectively contributes to an aquifer drawn on by a pumping well. Such boundaries may be provided by surface watercourses, by lakes, or by the sea when these lie within the radius of influence of the well.

All these may be regarded as discrete recharge boundaries and often are definable as point or line recharge sources for the purpose of analysis. Recharge boundaries have the effect of decreasing the rate of drawdown or checking the drawdown altogether. Downward leakage from overlying strata or the interception of natural flow through the aquifer may simulate a recharge boundary by decelerating the drawdown, but the effects cannot necessarily be identified with localized sources.

7 OTHER HYDROGEOLOGICAL FACTORS

There are several factors which may significantly affect the analysis of pumping test data although they may not affect the test itself. The thickness of

the aquifer should be ascertained at least approximately. Corrections are necessary in the analysis for partial penetration by the pumping wells. The degree of penetration of the observation wells is also important to ensure the measurement of realistic water levels.

Unconfined aquifers may demonstrate the phenomenon of delayed yield from storage. The rate of drawdown during the early stages of the test may be temporarily reduced for a period ranging from an hour to several weeks before turning to a more normal rate of drawdown. It may be necessary in these circumstances to prolong the pumping test to obtain sufficient drawdown data after the effects of the delayed yield have ceased.

During the period of a pumping test in a confined aquifer, water levels in the pumping well, and possibly in the observation wells, may fall below the confining bed. If this possibility exists, the depth of the base of the confining bed should be determined in all the wells to permit proper analysis of the test data.

ANNEX A

[Clause 4 (Part 2)]

GROUNDWATER CONDITIONS AND TYPES OF AQUIFERS

A-1 An aquifer is defined as a lithological unit containing sufficient saturated, permeable material to yield significant amounts of water to wells and springs.

When waterfalls onto the ground within an aquifer outcrop, or seeps into the outcrop from streams or lakes, a portion infiltrates downwards under the influence of gravity, moving through voids in the strata that do not become wholly saturated. This part of the aquifer is called the unsaturated zone (see Fig. 1) and all the water is at, or less than, atmospheric pressure.

Eventually, the infiltrating water cannot move downward any further, and all the voids become fully saturated. This part of the aquifer is called the saturated zone, and the upper boundary of this zone is called the water table. In practical terms, the water table is considered as that surface joining all the static (or rest) water levels observed in wells penetrating the saturated zone. An aquifer in which a water table is present is said to be unconfined.

Occasionally there exist in an aquifer impersistent layers of impermeable material which support small saturated zones. These are termed perched aquifers, with perched groundwater and perched water table. Perched groundwater is usually considered to be with in the unsaturated zone.

When groundwater is contained within an aquifer under pressure and beneath an impermeable confining bed there is no water table and no

unsaturated zone, the aquifer is said to be confined. When a well is constructed penetrating a confined aquifer, the water rises above the base of the confining bed to a level dictated by the hydraulic head. The surface formed by joining all the water levels observed in such wells is the piezometric surface.

An aquifer can be confined in one area and unconfined in another. In this case, the piezometric surface continues into the water table. In modern practice, the water table and the piezometric surface are called the potentiometric surface; the use of the term piezometric surface is declining, but when the potentiometric surface is within an unconfined aquifer the term water table is often used.

When the potentiometric surface in relation to a confined aquifer is above the ground surface, water is discharged without pumping from a well penetrating below the confining bed. This is called a flowing well. Aquifers may be classified according to the manner in which groundwater passes through them, and by the way in which groundwater is stored within them. In an inter granular aquifer, groundwater moves through the interstices between the constituent grains and is stored within these same voids. In a fissure flow aquifer, the matrix of the rock is relatively impermeable, and the water moves through fissures. In the latter case, it is not unusual for a significant amount of inter-granular storage to be present and the term mixed-or dual-porosity aquifer has been used.

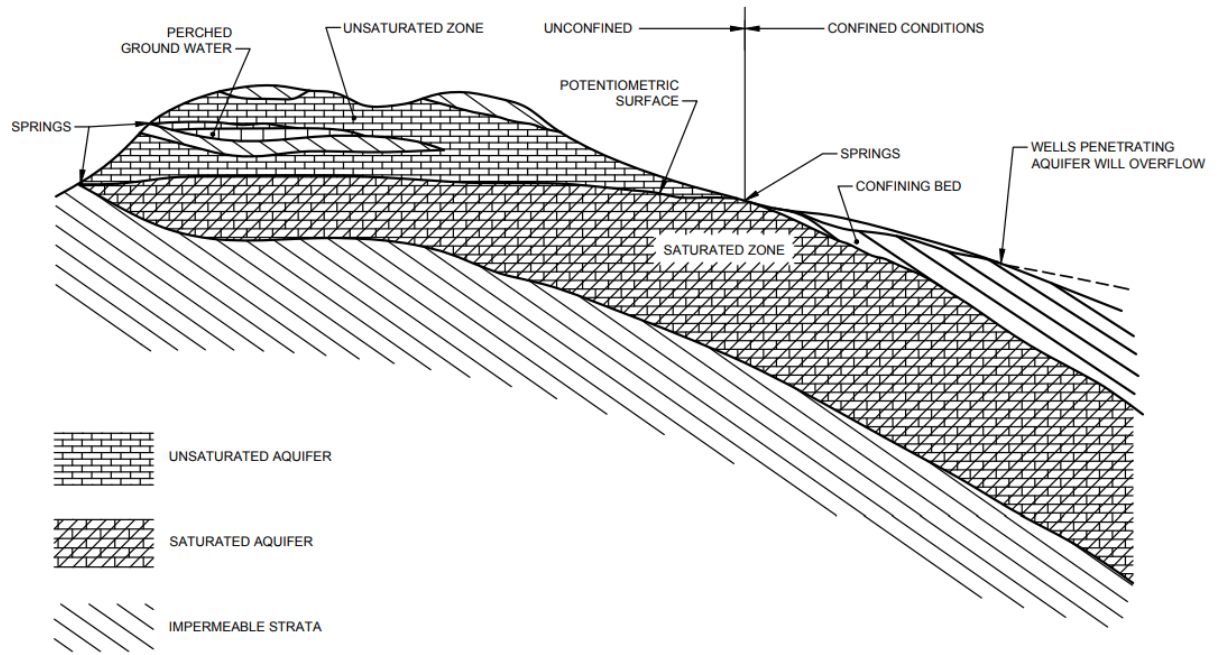

FIG. 1 GROUNDWATER CONDITIONS AND AQUIFER STATES

Indian Standard

PUMPING TEST OF WATER WELLS — CODE OF PRACTICE

PART 3 PRETEST PLANNING

SECTION 1 GENERAL ASPECTS

(*First Revision*)

1 SCOPE

This standard (Part 3/Sec 1) lays down guidelines for planning the aspects of site facilities, organization and utilities prior to a pumping test.

2 GENERAL

2.1 Sites within designated areas such as national parks, areas of outstanding natural beauty, areas of special scientific interest, etc or those close to or within residential areas may have special constraints imposed on test operations and these should be ascertained before any drilling or test pumping operation is commenced.

2.2 Persons planning to sink or test pump a well are advised to discuss their proposal in advance with appropriate regulatory authorities. Unless specifically exempted by the regulations, it should be ensured that procedures for obtaining permission, or consent, are followed before any work is carried out.

3 SITE FACILITIES AND ORGANIZATION

3.1 General

Guidance is given on general matters which affect the organization and activities of the test pumping site. The actual detail will vary from site to site and may include matters not described in this standard which, therefore, should not be assumed to be exhaustive in its coverage. Before any drilling or test pumping commences, a preliminary survey should be carried out bearing in mind these recommendations for site facilities and organization.

3.2 Space and Headroom

At the outset, it should be ensured that sufficient space is available for test equipment and pumping plant required on the site, as well as lagoons for disposal of acid sludge and other waste. Parking space for vehicles should be designated, and overhead obstructions such as power cables, guy lines, trees and so forth should be noted and clearly marked.

3.3 Safety on Personnel on Site

3.3.1 Every care should be taken to reduce the risk to personnel working on the site. First aid kits should be provided on site as a part of the normal safety arrangements and should be additionally equipped with soda for the neutralization of acid, when acid is to be handled during development of a well. Adequate supply of flowing fresh water should be available for washing acid from the eyes or sluicing it from skin or clothing.

3.3.2 Paths between the site hut, the test well, the observation wells, etc, should be clearly marked, as should hazards such as fences, cables, mud pits and spoil heaps. Sites which on initial inspection appear to be firm and dry often degenerate to a slippery morass around the well-head. The nature of the ground, therefore, should be carefully inspected beforehand and if necessary, arrangements be made to provide walkways for the working team.

3.3.3 If the test is prolonged through the hours of darkness adequate lighting should be provided.

3.3.4 The site inspection should reveal the presence of any overhead electric cables likely to be a hazard. Unless details are already available, a check should be made for the presence of underground electric cables or other services under the site, such as gas mains, telecommunication cables, sewerage lines, and their routes should be temporarily marked. In the case of overhead cables, a vehicle route beneath them should be established and clearly marked giving the minimum overhead clearance.

NOTE — The presence of either overhead or underground power lines may also affect certain types of electronic equipment, notably pH and ion selective meters and down hole logging equipment.

3.4 Utility Services

3.4.1 If electrically powered equipment is to be used, the possibility of availing a supply from the mains should be investigated. This should be done well ahead of mobilization to site since a temporary incoming switchboard and metering point is required. At the same time earthing arrangements

3.4.2 should be settled, if necessary, an earth leakage circuit breaker of suitable capacity may have to be provided.

If a main supply is not available it is necessary to install a generator of suitable capacity.

3.4.3 All electrical installations on the site should comply with statutory requirements and recommendations. Surface power cables between generator and well head should be armoured. Flexible braid armoured cable is more suitable and easier to handle in this application than single wire armoured cable. A water tight emergency stop lock-out button should be mounted within easy reach.

3.4.4 Special tests, such as certain types of packer test, will require water supply. Constraints may be applied on the type of water to be used, tankers may be required and possibly storage on site arranged. If the site is residential, it is necessary to provide a supply of potable water as well for general use. Where this is provided in containers these should be marked to distinguish potable from non-potable water.

3.4.5 If a telephone is required, it should be installed prior to commencing the test.

3.5 Site Accommodation

Suitable shelters should be erected upon the site, adequately lit. Such accommodation should include tables and seating for meals and facilities for preparing food,

The accommodation should be sufficiently secured to store first aid and fire-fighting equipment, test equipment, etc. If the test is to continue for one or more nights, sleeping accommodation should be arranged for off duty personnel.

If the operation is of a long-term latrines and washing facilities should be made available on site.

3.6 Site Communications

Signaling between the observation and pumping wells during the test can be carried out by visual or audible means, appropriate to the circumstances, for example by radio. Under some conditions visual signals may be inadequate.

3.7 Avoidance of Pollution and Disposal of Wastes

3.7.1 Care should be taken to dispose of liquid or solid wastes carefully and safely and in a manner that will not pollute the wells or the surrounding area. If it is not possible to dispose of contaminated

waste water directly into the sewerage system it should be collected and removed from site for treatment and disposal. Disposal of contaminated waste waters to a soak away, albeit remote from the well head, ditches and water courses, should not be undertaken without the consent of the regulatory authority. Solid waste should be removed from the site for disposal at a proper facility.

3.7.2 Precautions should be taken to prevent the well from infection by pathogenic and non-pathogenic organisms. The most likely source of pathogenic organisms is from latrine locations which should, therefore, be situated as far as possible from the well. Sterilization of any equipment to be placed in the well will reduce the risk of introducing infections from other sources.

3.8 Disposal of Pumped Discharge

Arrangements should be made for the disposal of pumped discharge, including any pipeline required. Ideally, the discharge point should be such as to exclude any possibility of recharge of the abstracted water into the aquifer. The location of the discharge point should be cleared with the local authorities. Special care should be taken to dispose the water beyond the zone of influence while testing on unconfined aquifer.

3.9 Noise

Continuous noise can be exhausting and have a deafening effect on personnel. An important consideration is the location and silencing of any internal combustion engine employed. There is added significance when the site is located near permanent habitation where noise nuisance during the night maybe unacceptable. Special arrangements should, therefore, be made for damping engine noise by the use of sound deadening enclosures around internal combustion engines, or by the use of baffle screens.

3.10 Maintenance and Storage of Equipment

Structures, plant, machinery, test and measuring equipment should be inspected at regular intervals in accordance with prescribed recommendations. In the case of a plant which is subject to corrosion, steps should be taken for effective repairs before corrosion reaches dangerous limits.

Electrically operated hand tools and lamps together with leads and earth wires, should be inspected at regular intervals to ensure that they have been maintained in good order and such inspections should be recorded. Trailing cables, except for hand lamps and small portable tools, should comply with relevant standards.

IS 14476 (Part 1 to 9) : 2024

It is recommended that equipment is sterilized before installation in the well, in order to avoid introducing any infection resulting from the previous use of the pump and column pipe in an infected well. The simplest method is immersion in a 1 percent (v/v) solution of sodium hypochlorite.

Phenolic agents should not be used to sterilize pumping equipment. Subsequent storage and handling of the pumping equipment should be such as to avoid the introduction of any polluting material into the wells.

*Indian Standard***PUMPING TEST OF WATER WELLS — CODE OF PRACTICE****PART 3 PRETEST PLANNING****SECTION 2 TEST DESIGN***(First Revision)***1 SCOPE**

This standard (Part 3/Sec 2) provides guidance on aspects that should be kept in mind while designing a pumping test.

2 GENERAL

The pumping test should be designed keeping in mind the objectives and taking into account the hydrogeological conditions of the site (*see* Part 2 of this standard) and the methods by which the results are to be analyzed. A systematic approach ensures that the maximum information is gathered about both the well and the aquifer. Such an approach requires close control of the design and running of the test, which can be achieved with little or no additional expense. It should be appreciated that the test is a scientific exercise providing a good database both for the aquifer and the abstraction of water there from.

Five types of pumping test may be considered as applicable. These are the equipment test, the step test, the constant discharge test, the constant drawdown test and the recovery test. The equipment test is carried out to check that the equipment is fully functional and to guide the operator with regard to obtaining suitable valve settings for the tests. The step test mainly provides information on well hydraulics. The constant drawdown, constant discharge and recovery tests provide information regarding the aquifer properties.

3 EQUIPMENT TEST

The equipment test provides a check that pumping equipment, discharge measuring devices and water level measuring instruments are functioning satisfactorily, and that all the equipments are in a safe condition with safety devices fully functional. It will also give sufficient data for planning the remaining tests, including data with which to determine appropriate values for valve settings for subsequent pumping tests.

4 STEP TEST

The purpose of a step test is to establish short-term yield-drawdown relationships and thereby define

those elements of head loss attributable to laminar flow (aquifer loss) and those attributable to turbulent flow (well loss). The step test comprises of pumping the well in a series of steps, each of which is at a different discharge rate. At least four steps are advisable, and the final discharge rate should approach the estimated maximum yield of the well. If the latter cannot be attained then the maximum capacity of the pump should be checked. Care should be taken to avoid excessive drawdown as this could result in the pump running dry and getting damaged.

The steps may be taken consecutively, the pumping rate changed at the end of each step, or intermittently, pumping stopped after each step to permit groundwater levels to recover before commencing the next step. In consecutive steps the pumping rate should be either increased in equal increments from the first to the last step, or decreased in equal decrements from the first to the last step. The latter is less common. In intermittent steps the pumping rate may be changed at random, the resultant data analyzed as a series of discrete tests.

Normally each of the steps should be of equal duration. It is rarely necessary for each step to last for more than 2 h but it is often convenient for each step to last 100 min for operational convenience and for plotting graphs.

Where observation wells are present, groundwater level measurements should be taken in them in addition to the pumping well. Observation wells are not necessary in the analysis of well performance but some indication is given of the range of groundwater level fluctuation that is produced in a test of longer duration.

5 CONSTANT DISCHARGE TEST

Constant discharge tests are carried out by pumping at a constant rate for a period of time dictated by the discharge rate and the local hydrogeological conditions. The purpose of a constant discharge test is to obtain data on the hydraulic characteristics of an aquifer within the radius of influence of the pumped well.

Observation wells are necessary in order to

determine fully the aquifer properties. [Table 1](#) gives the minimum durations that should be allowed for constant discharge tests. In certain situations, such as those described in this clause, in [8](#) and in Part 2 of this standard, increase or decrease in these periods will be appropriate.

The effect of a recharge boundary is a deceleration in the rate of drawdown. Where the recharge source is a specific feature, such as a watercourse or a lake, the elapsed time before the onset of this deceleration will increase in proportion to the source of the distance between the pumping well and the recharge source. Eventually drawdown will stabilize for the remainder of the test.

If a delayed yield effect occurs, the development of the time-drawdown relationship is delayed. It is not possible to estimate accurately in advance the length of the delay unless it has occurred in nearby wells previously tested in the same aquifer. If a delayed yield is expected, an extension of the duration of the test should be considered.

Barrier boundaries have the effect of accelerating the rate of drawdown and present a serious constraint on the yield of the well. The shorter periods given in [Table 1](#) may, therefore, require extension by one or two days to observe the effects adequately, particularly if they appear towards the end of the period as initially specified.

6 CONSTANT DRAWDOWN TEST

Constant drawdown tests (also called constant head tests) are used for tests with suction pumps, for design of dewatering schemes, for overflowing wells, for tests in piezometers and for tests using over capacity pumps. They may also have the same purpose as a constant discharge test.

In theory constant drawdown tests can be performed upon any aquifer, provided that a pump with a variable discharge rate can be controlled in such a manner so as to keep the drawdown to a particular constant amount. If the groundwater rest level is not expected to vary during the test period, then the constant drawdown is at a constant level, otherwise it is essential that the levels in control observation well are used to estimate the pumping level needed to maintain constant drawdown.

In a well which is not overflowing the test should be carried out in the same manner as a constant discharge test, except that the discharge rate should be controlled so as to keep the drawdown constant. Accurate measurement of the discharge rate is necessary.

In a well which is overflowing no pumping is

necessary. The procedure is to shut off the flow at the well head, and to measure the head of water thus contained. The well is then uncapped as instantaneously as possible, thus reducing the head to near well head level. The discharge rate is then measured at the frequency recommended for a constant discharge rate. The advantage of this type of test is that no pumping plant is required. Estimates for transmissivity, and crude estimates of the storage coefficient can be made without use of observation wells but such estimates are no more valid than similar estimates made without observation wells during conventional pumping tests. The minimum duration of the test should be sufficient for the discharge to reduce to about 1 percent of the initial rate.

NOTE — The minimum duration cannot be the same as for a constant discharge test (see [Table 1](#)).

7 RECOVERY TEST

The recovery test can be carried out upon any aquifer after a constant discharge test or a variable discharge test.

The recovery test requires careful measurement of the duration and rate of pumped discharge prior to the cessation of discharge. The recovery test can form a useful check on values of transmissivity derived from a discharge test. The specific yield or storage coefficient may be determined less accurately by this means. This is largely due to the incomplete re-saturation of the interstices within the aquifer dewatered during the test.

A recovery test dependent upon water levels measured in the test well, should only be performed if a foot valve has been fitted to the rising main. This is because, in the absence of such a valve, there tends to be a rapid rise in water level as water surges in from the rising main and also from the weir tank if used. A recovery test may be performed using only water level data obtained from observation wells, if the rising main in the test well is not fitted with a foot valve.

8 SURFACE WATER FLOW

Abstraction of groundwater will have an effect upon the natural discharge of water at the surface. Spring and stream flow depletion is often a major factor to be considered during a programme of test pumping groundwater, particularly if the proposed discharge is high. The feasibility of a study of this kind well depends upon the accuracy of estimating the difference between the flow measured during the test and the flow that would have occurred if the abstraction had not taken place. This in turn will

depend upon a number of factors including the scale of the abstraction relative to the surface flow, the distance between the test well and the surface flow, the point of discharge of the abstracted water and the accuracy and frequency of the surface flow measurement. Unfavorable condition's effects may be observable within a few days. This is not commonly the case, it is more usual for the test to have to last at least 2 weeks and in some

case 12 weeks, or more, in order to permit satisfactory analysis of the surface water flows. This is particularly the case when recirculation occurs with groundwater being discharged to a river and induced recharge taking place from the same river into the pumped aquifer. It is necessary also to consider the timing of the test in relation to the normal seasonal variations in surface water flow and the impact of climatic change.

Table 1 Minimum Duration of Constant Discharge Tests

(Clause 5)

SI No.	Discharge Rate m ³ /day	Minimum Duration of Constant Discharge Days (of 24 h of Constant Discharge)
(1)	(2)	(3)
i)	Up to 500	1
ii)	501 to 1 000	2
iii)	1 001 to 3 000	4
iv)	3 001 to 5 000	7
v)	Over 5 000	10

*Indian Standard***PUMPING TEST OF WATER WELLS — CODE OF PRACTICE****PART 3 PRETEST PLANNING****SECTION 3 OBSERVATION WELLS***(First Revision)***1 SCOPE**

This standard (Part 3/Sec 3) lays down the features to be kept in mind during drilling of observation wells for a pumping test.

2 PURPOSE AND CHARACTERISTICS OF OBSERVATION WELLS

In constant discharge test observation wells are necessary for the accurate determination of the properties of transmissivity and storage coefficient of the aquifer. The value of the transmissivity is obtained by a study of the shape of the cone of depression which is indicated by water levels in the observation wells surrounding the pumping well. Existing wells should be used if their dimensions and locations are suitable. In other cases, observation wells may need to be constructed before the test takes place.

The time taken for the drawdown to affect the observation wells is proportional to the square of their distance from the pumped well. Once drawdown commences at any point it may be rapid, irrespective of the radial distance from the test well. The magnitude of the drawdown is attenuated in proportion to the square of the distance from the pumped well.

3 NUMBER AND LOCATION OF PURPOSE DRILLED OBSERVATION WELLS

Preliminary calculations using estimated transmissivities, for example, estimated from existing borehole data, should be made to indicate the likely response in observation wells to pumping and hence to determine their spacing from the test well and the timing of the observations. Ideally, the minimum number of observation wells is four, arranged in two rows at right angles to each other, but in most instances one or two observation wells will suffice. This guidance assumes idealized aquifer conditions (isotropic and homogeneous aquifers). More complex conditions may require significantly greater numbers of wells. When a number of observation wells is required, their distances from the test well should approximate to a geometrical series. Based simply on the response and the state of the aquifer, the spacings in [Table 2](#) are a guide to the most favorable spacing of the closest of the observation wells for several example aquifers. Estimates of spacings in other lithologies can be made from an indication of their transmissivity and type curve. A spacing of less than 10 m from the test well is undesirable, the data obtained from closer distances presenting difficulties in analysis.

Table 2 Location of Observation Wells for Selected Lithologies*(Clause 3)*

Sl No.	Aquifer state	Transmissivity m ² /day	Measurable Response	Typical Lithology	Spacing from Test Well m
(1)	(2)	(3)	(4)	(5)	(6)
i)	Unconfined	50 to 500	Slow	Unfissured sandstone, sand, silt	25 to 35
ii)	Unconfined	Over 500	Fast	Fissured limestone, sandstone, gravel	25 to 60
iii)	Confined	50 to 500	Slow	Unfissured sandstone, sand, silt	60 to 100
iv)	Confined	Over 500	Fast	Fissured limestone, sandstone, gravel	10 to 200

Attention should be paid to boundary conditions that may affect the location (*see* Section 6 of Part 2). The distance from the test well may need to be reduced if the boundary is in close proximity.

In case of hard rock areas, fixed geometrical arrangement of observation wells may not be possible. The number and locations of the observation wells depend on the disposition of fractures/joints. The nearest observation well could be located as close as 10 m.

4 DEPTH OF OBSERVATION WELLS

Ideally observation wells should be constructed to the same stratigraphic level as the test well. In certain cases, however, in order to investigate particular localized phenomena, they may be drilled to a shallower depth than the test well.

In multi-layered aquifers inaccuracies will occur where observation wells penetrate only the uppermost layer or layers. The options available in this case are to drill one of the following:

- a) A single observation well to the full depth of the test well and to install piezometers against each aquifer level;
- b) A number of observation wells to different levels, lining out all levels except one in each well; and
- c) A single observation well open to the same stratigraphic levels as in the production well. Unless an extensive analysis is to be performed, (c) should give reasonable results.

5 OBSERVATION WELL DESIGN

Observation wells should be of small diameter in order to minimize the time in water level response due to storage in the well. Observation wells of 50 mm, 100 mm and 150 mm diameter are adequate for shallow, medium and deep depths respectively, where levels are to be recorded manually and observation wells are not to be fitted with instruments having floats or transducers.

Sensitive continuous recording equipment is needed to discriminate between drawdown and other effects on water level in distant observation wells. The justification for automatic equipment in observation wells relatively close to the pumping well is reduced if the test is of only a few days duration. In this case manual or visual water-level recording should be adequate.

Where a means of automatic water-level measurement is used, the installation and operation should be in accordance with specified instructions in every respect.

The usual size of recorder float used in observation wells is between 75 mm and 115 mm. Where steel lining tubes are used, and the depth of water level does not exceed 30 m (at full drawdown), an internal diameter of 150 mm is sufficient. Where the depth to water-level is greater than 30 m, an internal diameter of 200 mm is advisable since this reduces the possibility of the float and cable catching on the lining wall and producing steps or 'jumps' on the time-drawdown curve. If internally smooth thermoplastics or glass reinforced plastics lining tubes are used, a minimum internal diameter of 200 mm should be used. This is because there may be difficulty in maintaining sufficient verticality in a narrower lining tube to avoid fouling the float cable. Transducers may be of similar diameter than floats and since they do not travel continuously up and down the well, the diameter of the well should be sufficient only to contain the instrument.

Lining tubes should be carried down, if possible, to 2 m below the maximum expected depression of the water level. Floats tend to catch on the bare aquifer walls and may be lost if they catch on the end of the lining tubes when being withdrawn.

If screens are fitted, a minimum of 5 percent open area should be ensured to minimize lag between change of water level in the aquifer and that in the observation well.

If instruments are to be inserted into an existing well the recommendations in Part 8 should be taken into account.

6 DRILLING METHOD

The method by which an observation well is drilled should be recorded. The use of non-degradable drilling fluids such as bentonite mud should be avoided and development of the completed well should be undertaken to ensure the maximum hydraulic continuity between the well and the aquifer (*see* [Part 9](#)). This is particularly important in wells penetrating clay or chalk where the slurry may make an effective seal. When existing wells are used for observation purpose, the drilling method used for their construction should be considered and appropriate development undertaken.

Indian Standard

PUMPING TEST OF WATER WELLS — CODE OF PRACTICE

PART 3 PRETEST PLANNING

SECTION 4 TEST WELLS

(*First Revision*)

1 SCOPE

This standard (Part 3/Sec 4) lays down the features to be kept in mind during designing of a test well and making measurements therein.

2 GENERAL

The four basic objectives in correctly designing a test well are to facilitate the entry of groundwater into the well, the operation of pumping equipment, the collection of data from within the well and the measurement of pumped discharge.

3 GROUNDWATER ENTRY INTO THE WELL

The design of the well should enable free entry of water from the aquifer but preclude entry of aquifer particles, ensure that the well does not collapse and that the yield does not decrease over the long term.

The well should effectively tap the entire thickness of the aquifer so that the ground water flow towards the well can be assumed to be horizontal.

The well construction should be such as to contain the pump and column pipe and any additional equipment required in the well. The diameter should also be sufficient to prevent restriction of flow to the pump.

In all wells it is essential that a sufficient length of plain lining tube is placed to prevent the ingress of surface water and soil water as well as to guard against collapse of the well in the zone of loose weathered strata usually present close to the ground surface. The casing should be carried to a greater depth if certain aquifers are to be excluded, or if incompetent strata such as soft clay, are penetrated.

In unconsolidated intergranular aquifers, screens are necessary to prevent collapse of the well and to permit ground water entry. Filter packs around the screen are usually essential and may be either artificial packs of a uniform or graded type, or natural packs developed *in situ* from the aquifer.

4 PUMPING EQUIPMENT

One objective of the pumping test is to determine the type of pump suitable for permanent use in the well. The test pump may require a wide range of operative

yields a though some indication of the probable range required should be available from other wells in the same locality. The fact that a test pump is operating at less than the optimum efficiency is of little significance except in very prolonged tests.

It is advisable to avoid using the pump which will be permanently installed in the well since test pumping is a demanding and often abrasive duty. If the test programme calls for a wide range of discharge volumes there is a possibility that an electrically driven submersible pump may get overloaded at the extremes of the range. There is also excessive end thrust under nearly closed valve conditions which may give rise to thrust bearing failure if the condition is prolonged. It is recommended that the pump capacity should be adequate for discharges up to 25 percent greater than the required yield of the well for normal duty. The pump should be installed as low as possible so that maximum drawdown of water level is available to determine well capacity, however, sufficient space should be left underneath the pump to allow the settlement of any sediment so as to avoid blockage of the pump. To protect the pump from running dry, the pumping water level should always be kept a few meters above the pump suction level.

Wherever possible the pump should be positioned within the lined section of the well. In all cases the pump should be so placed that damage to the well screen or the collapse of an open well during installation or operation, is avoided.

The rising main should be of sufficient diameter for the maximum yield required to pass, without undue head loss.

It is recommended that the rising main is fitted with a non-return valve (*see Fig. 1*). This may be positioned either at the bottom of the column pipe or mounted on the surface. The former is the recommended arrangement, the foot valve being located in the discharge of a submersible pump or on the suction of a spindle pump, and if recovery levels are to be measured in the test well after completion of pumping, a non-return valve at the foot of the column pipe is essential.

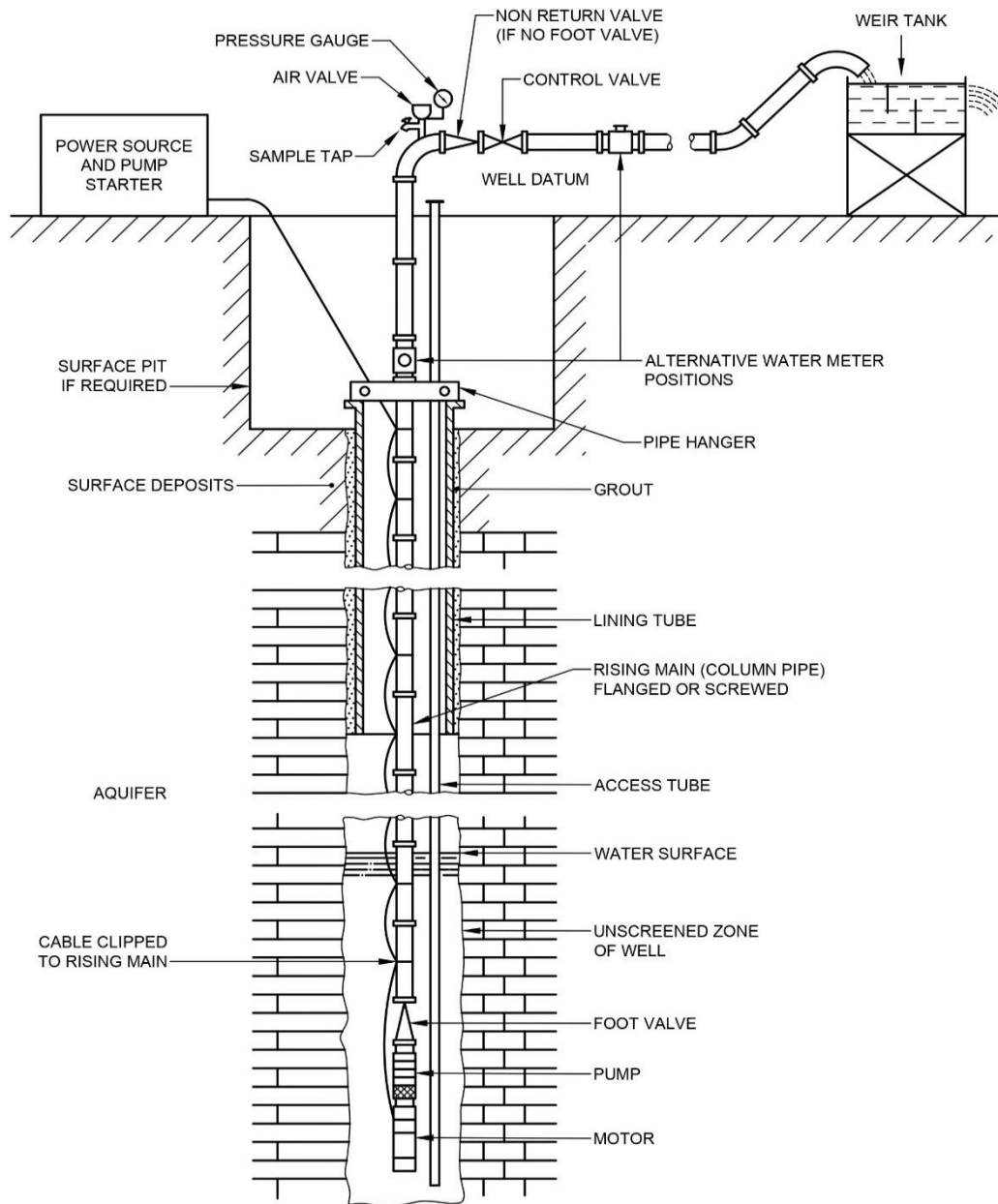

FIG. 1 TYPICAL ARRANGEMENT OF EQUIPMENT IN AN UNSCREENED TEST WELL

There are two reasons for mounting the non-return valve on the surface, the first being that the column pipe is empty when the pump is not running and therefore lighter to lift and secondly, if the well is prone to periodic entry of solids from an incompetent stratum, the back flushing action of an emptying column pipe after the pump stops, will tend to clear the pump of ingested solids. This procedure is not recommended if the column pipe is long, over

100 m as the back flushing water is likely to cause the pump to rotate at high speed in the reverse direction and loosen impeller lock nuts and bushes. It will also interfere with water level recording.

A valve capable of drip-tight closure should be fitted to the head of the column pipe to control the discharge rate. In the absence of variable pump speed control equipment this valve is operated

manually. An air valve preceding the control valve is useful in some circumstances for blowing off air at the beginning of a test. A stop cock is useful for taking water samples for analysis during the test. A discharge pipe, or channel, should connect the control valve to the flow measuring device. When a generator is required to power the pump and any other ancillary equipment, the power output should be approximately twice the power requirement of the pump so that high momentary starting currents can be accommodated without excessive slowing of the generator. When a well has been drilled through incompetent strata a settling tank or stilling pit should be provided at a convenient point in the discharge path.

5 MEASUREMENTS IN THE TEST WELL

Any instrument used in the test well during the test should be lowered through a specially inserted tube which should extend at least 2 m below the pump intake level. For water level measurement this tube should be three times the diameter of the probe of the dipper (*see Part 8*). If a vertical flow meter is to be used, an additional tube of larger diameter sufficient to accommodate it is required.

Vertical flow meters, temperature and electrical conductivity probes can be used to detect inflow horizons. The different types of geophysical logs are discussed in [Part 7](#) of this standard. Television cameras are sometimes used to supplement this information. Geophysical logs can be used before test pumping commences.

6 MEASUREMENT OF PUMP DISCHARGE

The most reliable method of measuring pumped discharge is to use a weir tank with the pumped water discharging over a V-notch or a rectangular notch.

Weir tanks and similar devices are accurate only if they are properly installed, used with great care, and if the notches or orifices are accurately machined and kept perfectly clean. In many cases a modern meter can be at least as accurate as a weir device, if correctly installed and recently calibrated.

A less accurate alternative to the weir tank is a sharp-edged orifice plate attached to the end of a horizontal pipe, at least 2 m in length. This method has some disadvantages because it is not as flexible in range or accuracy as the weir tank.

An individual meter is accurate only within a strictly specified range of flows. Within this flowrange, a meter can be as accurate as a weir tank.

Some meters are equipped with a flow rate indicator

as well as the more normal accumulative counter. It is difficult to obtain direct readings from such an indicator with sufficient accuracy for subsequent analysis. The counter values should be used. However, a flow rate indicator may be useful for setting the discharge rate. Further information on methods of measurement and equipment for measuring pumped discharge are given in [Part 8](#) of this standard.

6.1 Frequency of Discharge Measurements

The discharge rate should be measured and recorded at the same frequency as water level measurements (*see 7.2*). If continuous recorders are being used it may still be necessary to make manual measurements where instrument resolution is inadequate.

7 GROUNDWATER LEVEL MEASUREMENT

7.1 Methods of Measuring Groundwater Levels

The resolution of measurement in the test well should be 10 mm or better. Normally groundwater levels in the test well should be measured using a dipper or pressure transducer. In case of the latter, careful consideration should be given to the choice of equipment since it has to be capable of measuring over the entire anticipated range of drawdown at the required resolution. The measurement datum should be clearly marked on each well.

The resolution of measurement in the observation wells should be 5 mm or better. Unless data loggers are used, manual measurements are usually necessary during the initial period of a test since few mechanical recorders are capable of providing effective level values at time-intervals of less than 5 min. Some mechanical recorders can be read directly, either from graduated tapes or from a digital counter, thus saving the necessity of having a separate dipper. Measurement of groundwater levels at intervals of 15 min longer can usually be accomplished satisfactorily by continuous mechanical recorders.

Recent developments in data logger systems provide a means of monitoring both the test and observation wells with the potential for generating data in a format ready for rapid computer analysis and presentation. However, it is essential that careful attention is paid to the resolution and accuracy of the equipment and calibration by manual dipping will still be necessary.

7.2 Frequency of Water Level Measurements

Analysis of data is simplified if measurements taken in two or more observation wells are made simultaneously, particularly during the first hour of

the test. Some form of signal that can be heard or seen by all staff making measurements is, therefore, recommended.

During analysis, a time-drawdown or distance drawdown graph (as appropriate) and a time-recovery graph is used, the time being plotted on a logarithmic scale. In practice, where data is being collected manually the following intervals can be used as a satisfactory compromise:

- a) Immediately before discharge is started, stopped or changed;
- b) Every 30 set or 1 min for the first 10 min;
- c) Every 2 min thereafter up to 20 min;
- d) Every 5 min thereafter up to 60 min;
- e) Every 10 min thereafter up to 100 min;
- f) Every 20 min thereafter up to 300 min;
- g) Every 50 min thereafter up to 1 000 min;
- h) Every 100 min thereafter up to 3 000 mm; and
- j) Every 200 min thereafter until completion of the test.

NOTES

1 The intervals' listed in (a) to (j) relate only to the collection of data and are not recommendations for the

actual length of the test.

2 Measurement of water level in observation wells is desirable, when possible at 30 s intervals during the first 10 min of a test. Where a digital readout of water level is possible, or when one person measures water levels manually while a second person records them, measurements may be made at 30 s intervals. Where only one person is available, and measurements are taken manually, it is advisable for 1 min interval to be used during this period.

In the pumped well, it is difficult to measure water levels at close time intervals at the beginning of the test because of the rapid drawdown. The intervals between measurement should be as short as possible during the first 10 min, providing that the measurements are accurate.

8 MEASUREMENT OF TIME

The means used to measure time should be capable of measuring to the nearest second. During the first 10 min of the test, an error in time keeping greater than 5 s should be avoided. For the sake of general accuracy, time should be recorded to within 30 s until 1 h of pumping is completed, and to within 1 min, then onwards until completion of the test. Timing devices should be synchronized prior to the start of the test. It is convenient to start a test on the stroke of the hour

Indian Standard

PUMPING TEST OF WATER WELLS — CODE OF PRACTICE

PART 4 PRETEST OBSERVATIONS

(*First Revision*)

1 SCOPE

This standard (Part 4) lays down guidelines for hydrological, hydrogeological and meteorological observations to be made before carrying out a pumping test. These include observation of surface water, ground water and meteorological parameters as well as abstraction and discharge.

2 GENERAL CONSIDERATIONS

Hydrological, hydrogeological and climatological factors may influence the hydraulic behavior of an aquifer during a pumping test. It is necessary to assess the significance of these variables before test pumping takes place so that their effects can be accounted for in subsequent analysis. Some variables like rainfall and barometric pressure are independent of the pumping test. Others like groundwater levels and spring discharges are directly affected by the test. Many of these may require measurement throughout the test, and some may also be continued as post-test observations. Observations may also be required outside the area immediately affected by the test.

The duration and frequency of observations will depend on the rapidity of change likely in any given parameter. Where changes are cyclic, observations should cover several cycles. Where changes are in the form of a long-term trend, observations should be made for a pre-test period at least twice as long as the proposed duration of the test.

3 SURFACE WATER

3.1 Tidal Water

Tidal levels, where these may affect the test, should be observed over a period of at least two full tidal cycles, preferably during period of a spring tide. If possible, groundwater levels should be measured in two wells adjacent to the shoreline and the observations compared with the tide levels on the shoreline to obtain the tidal efficiency and tidal lag times at different distances from the shoreline. Measurements of level should preferably be made with a continuous water

level recorder. If taken manually, measurements should be at intervals not exceeding 15 min. Chemical analysis of groundwater from different depth in coastal wells and of seawater should be made to establish the characteristics of the waters. Repeated sampling of the well water or measurements of electrical conductivity during one or more full tidal cycles gives an indication of any saline interface that the well intersects.

3.2 Non-Tidal Waters

3.2.1 Surface Waters

Stage measurements should be made of surface waters, such as lakes or ponds, that may be affected by the test. If levels are not measured continuously, manual measurement should be made at specified intervals. The period over which observations are made should be sufficient to identify any natural trend which may occur during the test.

3.2.2 Stream Flow

Discharge rates from wells are frequently very small in relation to natural stream flows. In many circumstances, it is unlikely that any significant change in stream flow in response to pumping from a well, is measurable. However, measurements of stream flow should be made where possible, on water courses which may be affected by the test. Such measurements should be made at existing flow gauging weirs or at specially constructed sites. Temporary weirs or current meter sites may be necessary. Observations should be made, where possible, on a continuous recorder and should start at least 2 weeks in advance of the test.

3.2.3 Chemical Analysis

Samples of water from the sites listed in [3.2.1](#) and [3.2.2](#) should be taken and analyzed. If natural variation in quality is considered probable, systematic sampling may be necessary.

On-site measurements may be made for pH, electrical conductivity, temperature, redox potential,

total alkalinity, dissolved oxygen and specific ions. Laboratory determinations should be made for all major and minor ions, and bacteriological analysis should also be made.

3.2.4 Radioisotopes

Radioisotope determinations are occasionally made when there is a possibility of determining the relative ages of groundwater that is with a view to assessing whether recharge is occurring.

4 GROUNDWATERS

4.1 Groundwater Levels

Groundwater levels should be measured in specified observation wells and pumped wells within the area likely to be affected by the test. Levels may also be measured at sites beyond this area for control purposes.

Levels may be measured continuously or at specified intervals. Normally, they should be taken for a period of the order of twice the duration of the test. Subject to a minimum of 2 days, prior to the start of pumping.

4.2 Groundwater Quality

Groundwater samples should be taken from pumped wells and from specified observation wells in the vicinity of the test site. The analysis to be carried out should be similar to those in [3.2.3](#).

5 METEOROLOGICAL PARAMETERS

5.1 Barometric Pressure

Barometric pressure should be recorded in conjunction with the groundwater levels for a period sufficient to determine the barometric efficiency of the aquifer prior to the start of the test.

5.2 Rainfall

In the vicinity of the test site rainfall and other precipitation such as snow should be recorded in conjunction with the groundwater level measurements for a period sufficient to determine the response of groundwater levels to such events. It may be possible to make use of existing rain gauge networks.

6 ABSTRACTIONS AND DISCHARGES

All pumped wells, spring discharges or recharge operations in the vicinity of the test well should be monitored so that their effects on groundwater levels and quality may be taken into account during analysis of the test results.

Pumped wells in the vicinity of the test site should not necessarily stop pumping during the test. They should, however, be held as nearly as possible to a constant rate, both during the pre-test observations and during the test. If pumping is stopped then groundwater levels should be permitted to recover fully before the start of the test.

Indian Standard

PUMPING TEST OF WATER WELLS — CODE OF PRACTICE

PART 5 PUMPING TEST

(*First Revision*)

1 SCOPE

This standard (Part 5) lays down the procedure to be followed during various stages of the pumping test.

2 GENERAL CONSIDERATIONS

2.1 Test Programme

Normally, the sequence of events for a comprehensive test of both well and aquifer should be as follows:

- a) Equipment test;
- b) Step test;
- c) Constant discharge or constant drawdown test; and
- d) Recovery test.

2.2 Test Supervision

One person should be appointed to supervise the various tests. All decisions regarding the collection and recording of data before, during and after the test should be referred to the supervisor.

2.3 Staffing

The supervisor should ensure that all staff are familiar with the tasks they are to perform during the test and with any instruments that they are required to use. All staff should be aware of the frequency of water level measurements and the accuracy of measurement required. The staff should be advised of any safety regulations in force.

2.4 Equipment

The supervisor should ensure that all equipment is on site and in working order and that spare equipment or spare parts, including batteries for dippers, are readily available.

2.5 Timing

The supervisor should be responsible for determining the actual time at which the test starts and stops, and the times at which individual parts of the test start. The supervisor should also ensure that

the moments when measurements are to be taken are clearly signaled to the staff involved.

2.6 Record of Measurements

The supervisor should be responsible for issuing suitable forms for recording measurements and collecting and collating the completed forms. Some examples of data recording sheets are given in [Annex A](#).

The supervisor should keep a record of progress of the test with details of all operations carried out, including running plots of drawdown levels against time in the case of a constant drawdown test, so that an indication of the type of aquifer response is available.

2.7 Record of Well Dimensions and Distances

Depth, diameter, level above ordnance datum and other details of the test well and the observation wells should be recorded. These records should be attached to these records of measurement taken during the test. The records should include centre to centre distances of the observation wells from the test well. A plan showing the relative positions of the observation wells and the test well should be prepared.

3 EQUIPMENT TEST

The well should be pumped for a short period at discharge rates which need to be measured only approximately and with the drawdowns for each rate also measured. A check on the effectiveness of a well's development also should be made.

Groundwater level should be measured in the test well and any observation well prior to the start and in the observation wells just before the end of the equipment test. These measurements indicate the range of water level depressions that may be expected. The water level should be allowed to recover in both the abstraction well and the observation wells before any further testing is done. This recovery will normally occur within a few hours, during which time a record of the water level related to time should be made.

In the case of an overflowing well the head above the measuring point should be recorded before pumping or free discharge commences.

In an overflowing well where no pumping is to be undertaken, the equipment test is much simpler and comprises measurement of flow from the open well. The well should be capped off on completion of the test and the static head monitored.

Stream flow gauging equipment should be checked.

The control valve setting should be recorded during the equipment test so that in subsequent tests it is possible to set the value approximately to the pumping rate required without further adjustment. If a pressure gauge is fitted, it will be useful for determining setting for flow discharge rates.

4 STEP TEST

4.1 Duration and Number of Steps

The duration of each step and number of steps should be determined in advance. Any yield-drawdown curve obtained in the equipment test may be used as a guide.

In the case of an overflowing well, where it is considered that a constant drawdown test is adequate, the step test is usually omitted since adjustment to provide different heads is technically difficult.

4.2 Start of Test

Ideally, pumping should start instantaneously at the prescribed rate and continue at that rate until a change is desired. In practice this is generally not possible, however the following procedures are adequate:

- a) If a foot valve is not fitted, the pump should be started against an empty rising main with the control valve open to the first test setting.
- b) If a foot valve is fitted the pump should be started against a full rising main with the control valve fully closed or very slightly open, or opened up to the first test setting.

When it is proposed to start the pump against a closed valve, care should be taken that the pump is suitable for such an application. The pump should be started, allowed to run for a few moments, and at the specified moment, the valve should be opened rapidly to the setting determined to obtain the first discharge rate (using information obtained during the equipment test).

The control valve should not be adjusted again until either an increase in rate is required or until after the pump is stopped. Attempt should not be made to obtain an exact discharge rate but the actual rate should be carefully measured.

Rest water levels should be measured in the test well and in any observation wells prior to the start of pumping.

4.3 Test Procedure

4.3.1 Consecutive Step Test

It is convenient to start at a low rate of pumping, and to increase in steps to a high rate. The reverse may also be adopted, if preferred.

When changing from one discharge rate to the next, at the moment designated by the test supervisor, the control valve should be adjusted rapidly to the next setting for the required pumping rate.

4.3.2 Intermittent Step Test

The amount of change in the pumping rate between steps may be progressive or intermittent. Each step should be considered as a discrete test and should start under the procedure described in 4.2. At the end of each step the pump should be stopped and groundwater levels allowed to recover before commencing the next step.

4.4 Measurement of Groundwater Level

For each step in the test, groundwater level should be measured in the pumped well and observation wells at recommended intervals. If a constant discharge test is to be carried out later, groundwater levels during the step need to be measured in one or two observation wells close to the test well, since more distant wells may not show significant drawdowns during the relatively short duration of the step test. If a constant discharge test is not to be performed, the water levels in all available observation wells should be measured during the step test.

4.5 Analysis of Step Test

Full analysis of the step test is beyond the scope of this standard but a limited analysis is needed to estimate a maximum safe yield for the borehole. This is necessary for the design of the constant discharge rate test to maintain water levels above the pump. The usual method is to plot the specific drawdown (drawdown divided by discharge rate) against the discharge rate for each step. The drawdown is determined by extrapolation of the water level trend of each step to the end of the next

step. The points on the specific drawdown discharge plot should fall in a straight line. If the latter points diverge from this trend by an increase in specific drawdown, then the point of divergence is the safe yield. If no divergence occurs, then the greatest step discharge rate is the safe yield.

5 CONSTANT DISCHARGE TEST

5.1 Discharge Rate

The design discharge rate should be determined prior to the start of the test from the results of the equipment test and the step test and should approximate the likely operational discharge rate of the well in production. The instantaneous discharge rate during the test should not exceed either maximum step test rate or the safe yield (as defined in [4.5](#)).

5.2 Start of Test

The procedure as recommended for step tests should be followed (*see* [4.3](#)).

5.3 Measurement of Pumped Discharge

The pumped discharge should be measured as described in [Part 3/Sec 4](#) and [Part 8](#) of this standard.

5.4 Measurement of Groundwater Levels

Groundwater levels should be measured in the test well and in all observation wells at the intervals recommended in [Part 3/Sec 4](#) of this standard.

After 4 h of pumping, measurements are not required precisely at the specified intervals. It should be sufficient for one person to make the rounds of the manual dipping sites noting the time at which each measurement is made.

5.5 Duration of Test

The duration of the test should be as recommended in [Part 3/Sec 2](#) of this standard.

6 CONSTANT DRAWDOWN TEST

6.1 General

This test applies mainly to tests with suction pumps, dewatering, schemes and flowing wells.

6.2 Start of Test

If the well is to be pumped, the starting procedure is similar to that of the constant discharged test, differing only in that the discharge rate is carefully and frequently reduced in order to maintain a

constant drawdown.

When the test is made on an overflowing well, the well should be uncapped, or rapidly opened, at a pre-determined moment so as to produce, as nearly as possible, an instantaneous fall in head.

6.3 Measurement of Discharge

Discharge should be measured continuously as described in [Part 3/Sec 4](#) and [Part 8](#) of this standard. When the discharge becomes very small, containers of known size should be used and time taken to fill the containers recorded in seconds to the tenths of a second.

6.4 Measurements of Groundwater Levels and Static Head

The groundwater level or static head should be measured in the test well prior to commencing the test at the intervals recommended in [Part 3/Sec 4](#) of this standard. For overflowing wells, the height of the overflow above the casing rim should be estimated and recorded at intervals.

Groundwater levels or static heads in observation wells, where present, should be measured at the intervals recommended in [Part 3/Sec 4](#) of this standard.

Where static heads are too great for standpipes to be used, they should be measured with manometers. Pressure gauges or pressure transducers may be used provided they are sufficiently accurate.

6.5 Duration of Test

The minimum duration of the test should be sufficient for the discharge to reduce to about 1 percent of the initial rate.

NOTE — The minimum duration cannot be the same as for a constant discharge test (*see* [Part 3/Sec 2](#)).

6.6 Variable Discharge Test with Variable Head

It is possible to determine aquifer properties from a test where the static head and the discharge rate both vary, although the analysis is complex. Continuous monitoring of both - the static head and the discharge is necessary, otherwise procedures are the same as for a well with a constant static head.

7 RECOVERY TEST

7.1 GENERAL

Recovery tests in the well should only be performed if a non-return valve is fitted to the foot of the rising

main. Recovery tests carried out after step tests are difficult to analyze but they can give a further check.

7.2 Start of Test

The recovery test normally follows immediately upon the end of constant discharge or a constant draw down test. The discharge should be stopped at the designated moment by stopping the pump, or by capping the well as appropriate.

7.3 Measurement of Discharge

There should be no discharge from the well. The discharge rate, whether pumped or free flow, would have been measured during the period of the preceding pumping. These measurements are required for analysis of the recovery test.

7.4 Measurement of Groundwater Levels

Groundwater levels should be measured in the test well and in the observation wells at the intervals recommended in [Part 3/Sec 4](#) of this standard, starting from the time discharge ceases.

7.5 Duration of Test

The test should be continued until a stable level has been achieved.

8 INTERRUPTIONS OF TESTS

8.1 Breakdowns

Normally, the pumping plant should be serviced prior to commencement of pumping. If it breaks down to the extent of stopping the discharge at any time during a step test, or during the first 24 h of a constant discharge or drawdown test, groundwater levels should be allowed to recover and the test started again. In the case of a step test, pumping may be resumed at the rate taken for the previous step and the result from previous test steps may still be valid. Once a constant discharge or drawdown test has been in progress for 24 h, thereafter breaks in pumping of up to 1 h can be accepted although provision should be made for unbroken abstraction in the case of specialized tests.

Measuring devices can malfunction and it is advisable to have standbys available, especially in the case of dippers, in order to avoid breaks in the collection of data.

8.2 Falling Groundwater Levels

If the groundwater level in the test well is approaching the pump suction level, and the indication is that this level will soon be reached,

pumping should be stopped. A further test may be carried out at a lesser discharge rate. A recovery test, carried out when pumping has stopped provides useful dam upon which to decide whether further testing is feasible or necessary.

8.3 Developing Wells

Test wells which have been inadequately developed may show some development during the test. In these circumstances a constant discharge or drawdown test is not necessarily compromised. The effects of the lack of development are confined to the test well and will have no effect upon the observation wells. However, if lack of development is indicated during the step test, the latter should be stopped immediately and the well properly developed before recommencing testing (*see* [Part 9](#)).

Failure of an observation well to show drawdowns may be due to inadequate development. Complete or partial hydraulic isolation of the well water from the aquifer should be considered unacceptable and the observation well should be developed before testing.

8.4 Other Interruptions

Once a well test has started it should be completed if possible. The fact that a particular well proves to have an inadequate yield for its proposed operational requirement should not be a sufficient reason for automatically considering abandoning a test.

9 MEASUREMENT OF AQUIFER RESPONSE DURING CONSTANT DISCHARGE AND DRAWDOWN TESTS

During a discharge test time-drawdown or time discharge graphs (as appropriate) should be kept for the test well and the observation wells. These graphs should be constructed both on linear-log and log-log paper in both cases, with time plotted on a log scale. The is type curves for $W(u)$ against u and $1/u$ should be made available on log-log paper of the same scale.

NOTE — $W(u)$ is a non-dimensional exponential function referred to as the well function and u is a parameter.

Comparison of the observed curves with the The is curve will indicate departures from the ideal case. Similarly, flexures in the normal straight-line plot on the linear log plot may also indicate departures.

If such a departure is observed, immediate steps should be taken to check that the measurements have been taken correctly, the pumping plant is functioning properly and the discharge rate is being maintained. If these factors are not at fault, it can be assumed that the departure is due to an aquifer

condition. Some departures due to well losses may be found in the pumped well as well.

10 QUALITY OF GROUNDWATER FROM THE TEST WELL

Samples of water should be taken from the test well to determine the groundwater quality and whether there is any variation. The analysis may include those in Part 4 of this standard.

Geophysical logging may be of assistance in determining the position of suitable sampling points when these are in the well itself.

11 STREAM FLOW DEPLETION

Surface water (streams, canals, etc) may be captured

by a pumped well and be reflected by the water level and response in the pumped and observation wells. Flow measurements from bodies of surface water should be made before, during and after constant-discharge or constant-drawdown tests by structures or by current meter gauging. As a minimum, a record of stage should be kept from any nearby bodies of water. If possible, this stage record should be of a continuous type (15 min measurement frequency). Weirs should be fitted with continuous recorders. Where current meters are used, it may not be possible to make frequent measurements of flow. Abstractions of groundwater and surface water and discharge into the watercourses of industrial and domestic effluents, all of which are likely to be variable, need to be considered as well as run off from precipitation.

ANNEX A

[Clause 2.6 and (Part 5)]

EXAMPLES OF FORMS FOR DATA COLLECTION

A. Example of reference form for recoding of site details

Aquifer test : site details

Country _____	Nat. Grid Ref. _____	} of pump well
Locality _____	or co-ordinates _____	
	Ref No. _____	
Size _____		
Single _____ or multiple _____ pumping well test		
Aquifer(s) _____		
Time _____	Date _____	of start of main _____ or preliminary _____

Depths and other details for each well are measured from the permanent datum. Datum elevations are relative to sea level _____ or to site datum _____

at.....
which is _____
 above sea level.

Pump details: Electric submersible from mains _____ from generator _____ vertical turbine _____
 are lift _____ surface _____ piston force _____ piston lift _____

other..... Pump suction at _____

below well datum. Yes/No Foot valve fitted Yes/No Non return valve on discharge main Yes/No

Nominal discharge rate(s): _____

Was maximum discharge rate limited by capacity of pump? Yes/No

Any problem with pump?.....

Discharge measurements by: Flowmeter(s) (state how many) _____ orifice or venturi meter _____

Weir tank _____ volume tank _____ other _____

Any problems with measuring devices?.....

Aquifer details : Known or suspected influences:

Barometric _____ tidal _____ river _____ other loading _____ other pumping _____

Barrier boundary _____ recharge boundary _____

other influence.....

Aquifer believed to be: confined _____ semi confined _____ unconfined _____

Pumping well fully _____ partly _____ penetrates aquifer Aquifer base at _____

Aquifer top at _____

No. of samples taken for chemical analysis _____ for radioisotope analysis _____

Geophysical logging carried out of formations _____

Fluid logging carried out at test _____ while pumping _____ TV inspection _____

Record meter readings and water levels before start of pumping

Check that weir tank is level: before test _____ after test _____

Turn over and enter details of pumping well(s) and observation well(s)

IS 14476 (Part 1 to 9) : 2024

Completed by.....Date.....

(continued reverse side of form)

Well name	From Test Well		Well Datum Elevation	Depth	Diameter	Cased intervals	Perforation			Rest water level (R.W.L)			Remarks
	Distance	Bearing					From	To	Opposite (formation)	Water level above datum	time	date	
	*		*	*	*	*	*						

B. Example of comprehensive data form for completion on site

Aquifer test : observations

Variable measured..... <hr/> Country Locality.....	Observations in <input style="width: 100px;" type="text"/> well during <input style="width: 150px;" type="text"/> (test name) Type of test <input style="width: 100px;" type="text"/> (draw down, recovery etc.) Sheet _____ of _____
--	--

Drawdown phase no Recovery phase Preliminary test

This phase commenced Main test
 Time

Day Month Year

Measurement by: Auto recorder Electric probe Other

Permanent datum description..........Perm.
 datum elevation

Factor for converting recorded measurement

Date	Time	Flapsed Time since Pumping Started or Stopped		Water Level Below Datum	Drawdown	Discharge	Notes
		Days	Minutes	*	*	*	*

Indian Standard

PUMPING TEST OF WATER WELLS — CODE OF PRACTICE

PART 6 SPECIAL TESTS

(*First Revision*)

1 SCOPE

This standard (Part 6) lays down guidelines for conducting slug test and packer tests.

2 GENERAL

These tests can be carried out using a single borehole in order to study the characteristics of an aquifer along the open section of the borehole. Such tests may comprise of normal pumping with concurrent observation boreholes. Alternatively, injection tests may be performed, either into the open borehole in the case of slug test, or into sections of the borehole in the case of packer tests. In both cases, free access to the borehole, a supply of water and apparatus to lower the necessary equipment into the borehole are required.

Slug tests are also useful where pumps cannot be installed or where sufficient depth of water is not available for normal pumping. Packer tests are useful to know the approximate values of aquifer parameters and water quality of the individual aquifer zones.

Slug tests and packer tests are specialized procedures and should be undertaken only with specialist advice.

3 SLUG TEST

3.1 General

The slug test involves relatively small displacements of water levels in a borehole by the rapid injection of a 'slug' of water with a bailer, or by the introduction of a mechanical displacer.

Whichever process is used, speed is essential. The reliability of the data depends upon the availability of numerous observations over a short period of time. The nearest approach to an instantaneous change in water level is obtained by the use of a displacer. The use of rapid water injection depends upon the availability of a suitable supply and an efficient apparatus for introducing it into the borehole.

Analysis of slug test data can provide information on the transmissivity of the formation which is open or

screened, in the well being tested. Given some knowledge of the transmissivity, a slug test in an observation well can indicate whether the well has been developed effectively and is in good hydraulic continuity with the aquifer, or if further development is necessary slug tests may also be carried out in sections of the well isolated between packers (*see 4*).

3.2 Displacer

The normal displacer comprises of a hollow, sealed tube, heavily weighted internally and of known volume. The size should be sufficient to raise the water level in the borehole by at least 2 m upon total immersion. In boreholes of small diameter, drill rods with a closed end may be adequate.

3.3 Water Level Measuring Device

The usual float-operated recorder is not satisfactory in this situation and the electrical contact type dipper cannot measure changes in the water level as quickly as desired. The ideal instrument is the pressure transducer, sensitive over a few meters range. The transducer should be located 1 m below point. The cable connecting the transducer to the well head may require protection within an access tube. When water injection is being used, the transducer should be located 1 m to 2 m beneath the rest water level.

3.4 Recording Apparatus

Either a chart recorder capable of reading rapid input changes or an electronic system incorporating a data logger is required. It is also necessary for time intervals to be recorded automatically.

3.5 Procedure

When the displacer is used, it should first be lowered into the borehole until its base is resting within the water surface. When the recording instruments are running, the displacer should be lowered rapidly until 95 percent is submerged. When the water levels have stabilized the displacer should be raised rapidly until it is clear of the water and the water levels again allowed to stabilize. The test should be repeated several times. Adjustments in recording speed may be required to obtain usefully spaced data,

depending upon the speed with which the water levels recover.

When using water injection, the process is analogous to the insertion of the displacer, but cannot simulate its withdrawal. The injection should comprise of a volume of water equivalent to 2 m to 3 m depth of the borehole.

When a bailer is used it should be lowered until approximately 80 percent is submerged, and the water levels allowed to stabilize. The bailer should then be lifted rapidly until clear of the water surface, simulating the withdrawal of the displacer. The test should be repeated until at least five comparable cycles have been completed.

3.6 Safety Precautions

Slug tests cause rapid movements of water level in the borehole. They should not be carried out where the resultant rapid pressure changes could cause collapse of the borehole wall, or where serious particle rearrangement would be caused in a filter pack.

3.7 Screened Boreholes

When a borehole has been fitted with a screen with a limited open area per unit length, a slug test may provide little useful information upon the aquifer characteristics but can provide information on the degree of development of an observation well. An open area of at least 10 percent should be considered as the limiting value.

4 PACKER TEST

4.1 General

In layered or fissured aquifers, it is sometimes necessary to have quantitative knowledge of the variation of hydraulic conductivity with depth, and hence the contributions which the various layers make to the total transmissivity of the strata through which the well has been drilled and also to know the water quality of the individual aquifer zones. In these circumstances the use of packer tests, in which the chosen section of the well is isolated by one or more packers, provides a better alternative to sinking several pumping and observation wells to various depths.

A packer is a cylinder of a diameter slightly less than the borehole and fitted with an inflatable jacket. On being located at a particular level within the borehole the jacket is inflated by gas pressure, fluid pressure or mechanical means and the packer forms a watertight plug in the borehole. The packer may be blind, or access to the borehole beneath the packer

may be provided by a tube leading from the well head through the base of the packer.

The use of packers in boreholes fitted with screens requires special care as borehole fluids may otherwise bypass the packer. The same applies where large fissures in the aquifer prevent a watertight seal. Attempt should not be made to seat packers in strata that will not stand without support, or within broken rock which the packer may displace. Borehole testing using packers can be undertaken by:

- a) Pumping water out of a well; and
- b) Injecting water into a well, often at pressures exceeding those afforded by gravity alone.

In the first case, the hydraulic conductivity of the strata within the section of the borehole under test is evaluated from the relation developed between the drawdown and abstraction rate. In the second, the hydraulic conductivity is evaluated from the pressure head and injection rate. Pump-out packer tests are used where the aquifer has a moderate or high hydraulic conductivity, they require a well of sufficient diameter to allow the passage of pumps and water level measuring apparatus. A water supply is not needed. Samples of water should be taken for chemical analysis.

Injection tests can be used in aquifers with either low hydraulic conductivity or a high hydraulic conductivity. The technique is used frequently for site investigation. Large amounts of water are likely to be required. [Fig. 1](#) shows the typical arrangement of equipment for a double packer injection test.

4.2 Types of Packer Test

A test using a single packer simply divides the borehole into two sections. The advantage of this arrangement is that it can be used during pauses in drilling operations, testing successive sections as the borehole is advanced. However, there is a disadvantage in that the test section is undeveloped and the hydraulic conductivity of the borehole walls, and hence the apparent hydraulic conductivity of the aquifer, is likely to be reduced by the wall-cake produced in the drilling process.

The more common double packer systems use two packers, a known distance apart, isolating a test section of the borehole at a specified depth (*see* [Fig. 1](#)). Prior to the test, the borehole is developed in the normal manner. After each test, the packer system is relocated to isolate a different test section. Where a continuous profile is required, each test section should slightly overlap the previous section.

4.3 Equipment

The equipment comprises of the packer units, inflators, a pump for abstracting or injecting water, and apparatus for measuring pressures and flow rates. The equipment is specialized, and experienced operators are essential. Attention should be drawn to the dangers inherent in using gas-mated packers where high pressures are involved.

The standard sizes of packers are suitable for boreholes of 75 mm to 200 mm diameter, although diameters up to 300 mm are available. When the double packer system is used, the distance between the packers is usually fixed, and varies from 3 m to 6 m, depending upon the test requirements.

4.4 Test Schedule

A test cycle should normally consist of five steps during each of which water is abstracted from, or injected into, the test section of the borehole at a constant rate or pressure. When carrying out an injection test care should be taken that the injection pressure is not so great that it causes fracturing of the overlying rock. In each step, the pressure should be held constant for 15 min, with the total injected volume of water recorded at intervals of 5 min.

Changes of pressure between steps should be made as quickly as possible. The pressures need not be adjusted exactly to the target levels, provided that precise values are recorded.

4.5 Recording Results

For each test section, specified by depth below surface, the applied drawdown or pressure should be tabulated against the abstraction or injection rate, as appropriate. When measuring pressure, unless transducers or the like are used to measure the pressure in the tested section directly, the length, diameter and material of the pipe work should also be recorded since the applied pressure needs correction for pipe friction loss. The interpretation of the results involves the calculation of hydraulic conductivity from simple formulae and, with care, an accuracy within an order of magnitude is attainable.

4.6 Overflowing Wells

Although packer tests can be used in overflowing wells, the techniques described in [Part 3/Sec 2](#) are recommended. Allowance should be made for partial penetration effects during the analysis of the results.

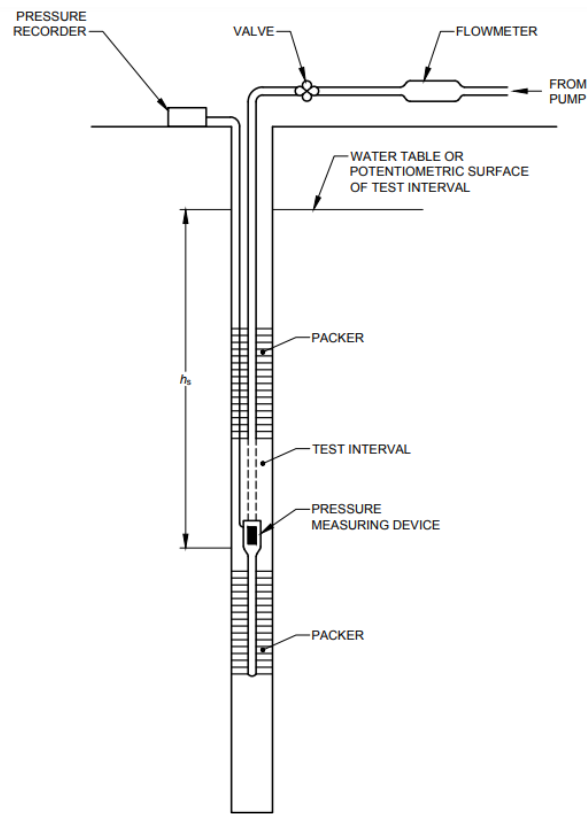

NOTE — h_s is the head on the pressure measuring device under static conditions.

FIG. 1 TYPICAL ARRANGEMENT OF EQUIPMENT FOR A DOUBLE PACKER INJECTION TEST

Indian Standard

PUMPING TEST OF WATER WELLS — CODE OF PRACTICE

PART 7 POST TEST OBSERVATIONS AND PRESENTATION OF DATA

*(First Revision)***1 SCOPE**

This standard (Part 7) lays down guidelines for post-test observations and presentation of data of a pumping test.

2 POST TEST OBSERVATIONS

The measurement of significant variables during recovery from pumping until the return of pre-test conditions forms an integral part of the test. Monitoring of the variables described in [Part 4](#) of this standard should continue for a period after recovery to establish trends prevalent during the test pumping periods.

3 PRESENTATION OF INFORMATION

3.1 Clear and consistent presentation of the test sampling data and results can significantly improve the decisions to be made when the test pumping programme has been completed. All the original data sheets and recording charts from automatic measuring devices should be retained for subsequent analysis and to support any charts prepared for the final presentation of data.

3.2 Two types of charts should be prepared, both relating to the period of test pumping and a sufficient period beforehand, to establish a rainfall aquifer replenishment correlation, for which purpose all levels.

The fast chart should be a vertical section through the test well, extending to about 5 km on either side of it and showing existing wells and ground levels plotted at their radius from the test well, with simultaneous test observation well water levels and surface water levels shown before, during significant steps of step tests and after test pumping. Where boreholes are not actually on the chosen line of section, they may be projected on the chosen line, or the section may be varied in order to take in additional boreholes (*see* [Fig. 1](#)).

3.3 The second chart should comprise of continuous plots of precipitation, barometric pressure, ground water level in the test well and pumping rate against the corresponding time scale, and should particular is test pumping operational

procedures like surging operations and their results (*see* [Fig. 2](#)).

4 GEOPHYSICAL LOGGING**4.1 General**

Test pumping at times, may require geophysical logging of the well, which could provide support to interpretation of the test results. [Table 1](#) lists various types of geophysical logging used in water wells and their applications and limitations. Formation and construction logging may be run in a borehole almost at any time and fluid logging both prior to commencement of pumping and again during the test for comparative purpose.

4.2 Formation and Construction Logging

Formation and construction logging provide information on the physical features of the borehole and assist in the geological and hydro geological interpretation of a borehole site.

Formation logging is generally carried out prior to the test. Construction logging should be carried out before installation of any pumping equipment or introduction of any substances to clean or develop the borehole (most commonly hydrochloric acid). The basic suite of formation logs commonly used includes S.P electrical resistivity and natural gamma. These provide assessment of the properties of the formation and the pore waters contained in them. A caliper log in addition to describing the dimensions of a well, can provide information useful for the interpretation of the fluid logging and may be essential if other logs being run require diameter correction. Caliper logs should be run prior to the test. There may be a need, in some instances, to repeat this log afterwards to examine such effects as collapse of erosion.

4.3 Fluid Logging

Fluid logging could be carried out before, during and after the test to investigate the groundwater flow in the well in relation to the immediately surrounding aquifer. The logs normally available are fluid temperature (also differential temperature) fluid conductivity (also differential conductivity) and flow.

The logging cable and sensors (sonde) should not pass a working pump unguarded. Therefore, where logging below a pump is necessary, an access tube terminating just below the pump should be installed. Logging above the pump is carried out in the annular space between the pump rising main and the wall of the well through a separate opening in the well head. Care is needed to thoroughly check the diameter of the probe and the annular space to avoid

entangling of the probe with the power cable and the rising main or other obstructions. A screwed rising main results in more room for access and less risk of cable fouling, compared to a flanged rising main, and is, therefore, preferred. The power cable to the pump should be clipped to the rising main at frequent intervals to prevent looping (flanged main is at a disadvantage in this respect also).

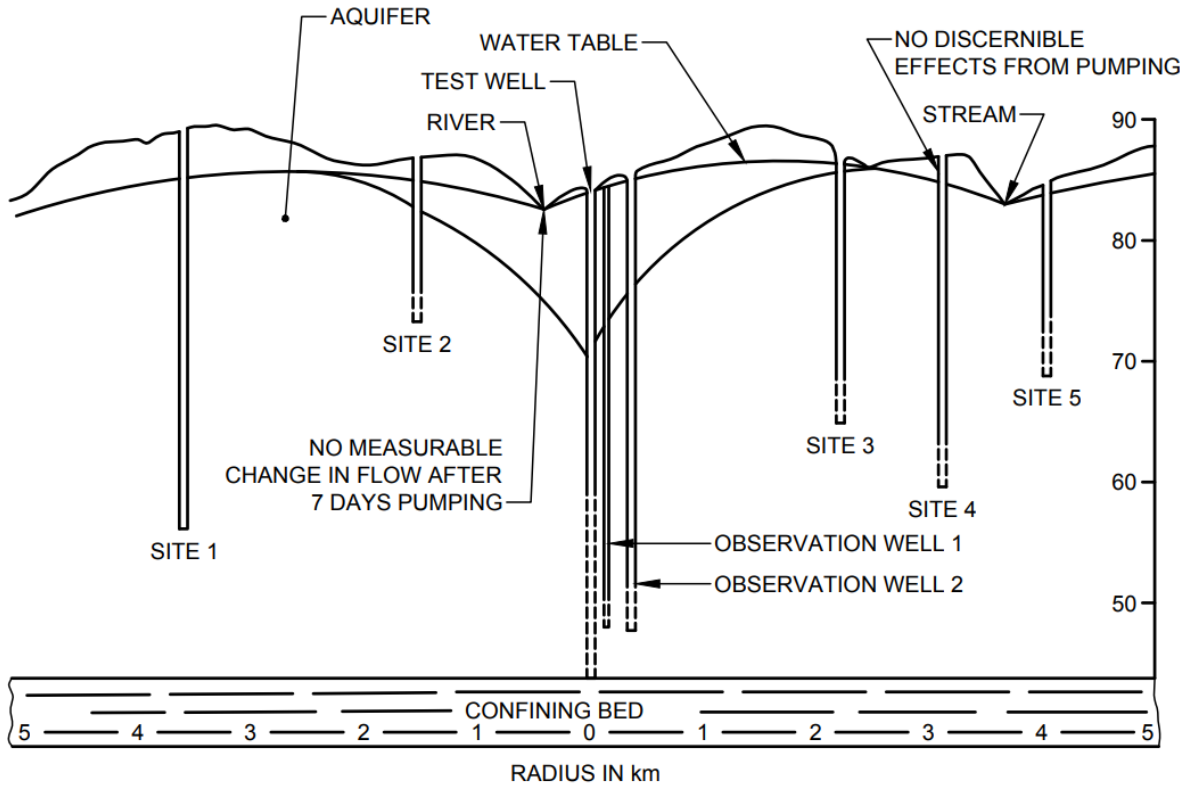

FIG. 1 TYPICAL VERTICAL SECTION THROUGH TEST WELL AND ENVIRONS

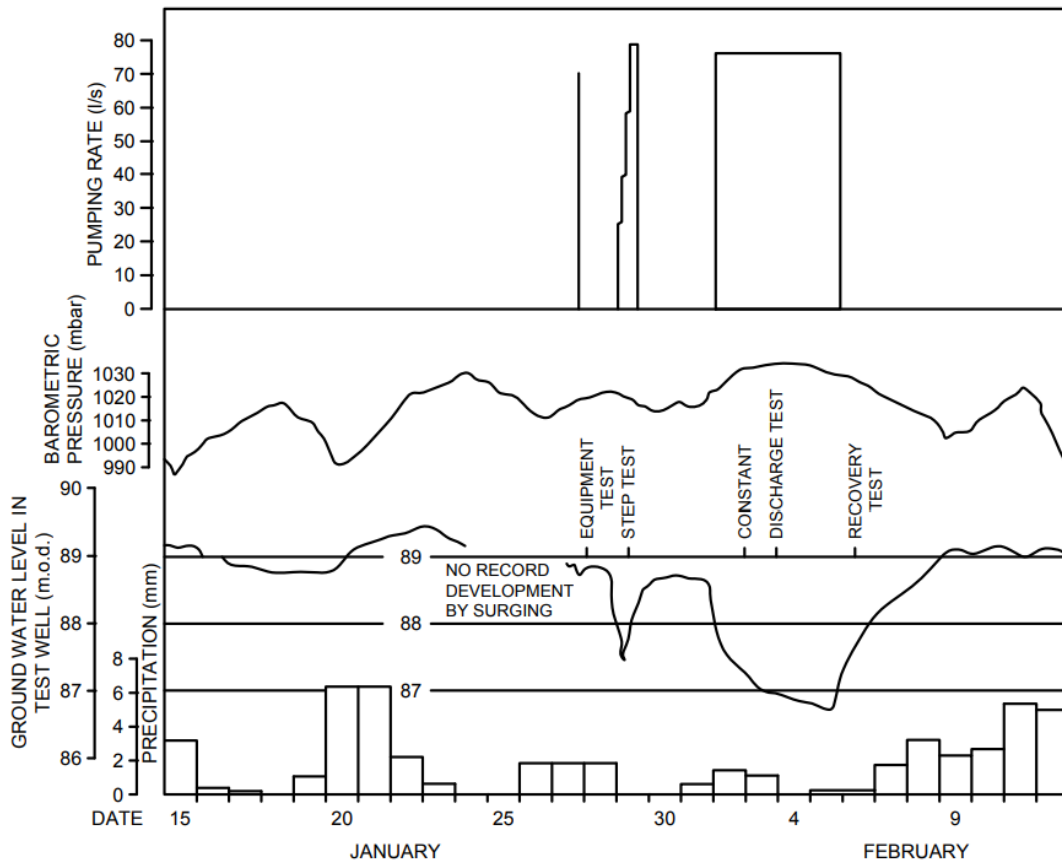

FIG. 2 CONTINUOUS PLOT OF PUMPING TEST DATA

Table 1 Application and Limitation of Geophysical Logs

(Clause 4.1)

Application	Fluid Properties				Formation and Construction Features														Limitations					Sonde Features							
	Borehole fluid quality	Fluid movement	Formation fluid	Water level	Lithology	Bed thickness	Bed boundaries	Correlation	Permeable zones	Porosity	Density	Casing features	Casing location	Cement bonding	Cement location	Collapses	Caving behind	Diameter	Fissures	Air filled	Mud filled	Water filled	Lined (steel)	Lined (plastics)	Open hole	Quality reduces	Borehole diameters	Centralized	Free	Sidewalled	Typical logging speeds
																											mm				m/mm
Resistivity (normal, lateral, focussed)		*	*	*	*	*	*	*	*			*							*		*	*			*	*	> 100		*		5 to 15
Single point resistance			*	*	*	*	*	*				*							*		*	*			*	*	> 100		*		5 to 15
Self potential		*	*	*	*	*	*	*	*											*	*	*			*	*	> 100		*		5 to 15
Induction		*	*	*	*	*	*	*	*			*							*	*	*	*		*	*	*	> 100		*		3 to 10
Natural gamma					*	*	*	*											*	*	*	*	*	*	*	*	100 to 300		*		3 to 6
Neutron-neutron			*	*	*	*	*	*	*										*	*	*	*	*	*	*	*	100 to 300			*	3 to 6
Gamma-gamma			*	*	*	*	*	*	*	*	*	*	*	*	*	*	*	*	*	*	*	*	*	*	*	*	100 to 300			*	3 to 6
Sonic			*	*	*	*	*	*	*	*	*	*	*	*	*	*	*	*	*	*	*	*	*	*	*	*	100 to 300	*			5 to 10

*Indian Standard***PUMPING TEST OF WATER WELLS — CODE OF PRACTICE****PART 8 WATER LEVEL AND DISCHARGE MEASURING DEVICES***(First Revision)***1 SCOPE**

1.1 This standard (Part 8) lays down guidelines for water level and discharge measuring devices to be used for test pumping of water wells.

1.2 This standard also describes methods of measurement and gives practical guidance in the use of conventional water level recorders. These operate by the movement of a float within the recorders. These operate by the movement of a float within the borehole or stilling well of a weir tank.

2 REFERENCES

The standards given below contain provisions, which through reference in this text, constitute provisions of this standard. At the time of publication, the editions indicated were valid. All standards are subject to revision, and parties to agreements based on this standard are encouraged to investigate the possibility of applying the most recent edition of these standards:

<i>IS No.</i>	<i>Title</i>
IS 9108 : 2020/ ISO 1438 : 2017	Hydrometry — Open channel flow measurement using thin-plate weirs (<i>second revision</i>)
IS 14615 (Part 1) : 1999/ISO 5167- 1 : 1991	Measurement of fluid flow by means of pressure differential inserted in circular crossSection conduits running full: Part 1 : General principles and requirements (<i>first revision</i>)

3 MEASUREMENT OF WATER LEVEL**3.1 General**

Pumping tests are often short affairs, and temporary installations of water level recorders are frequently required. Therefore, operating manuals should be available giving full instructions, illustrated by diagrams, where necessary, on the following:

- a) Setting up and chart or tape changing procedures;

- b) Calibration;
- c) Normal maintenance and servicing;
- d) Spares list; and
- e) Dismantling and transport.

Levels in a borehole are required to be measured to the nearest 0.01 m, those in a stilling well of a weir tank are required to the nearest 1 mm.

The range of operation can be increased by the use of different gearing systems in both level measurements and timing. The choice depends upon the requirements for each individual pumping test or well or borehole. There are obvious difficulties in using floats and counterweights in a borehole that contains a rising main, an electric cable to the pump, and access tubes. Special care should be taken to clamp these together and allow as much room as possible for the recorder float in its own tube.

The initial rapid drawdown and turbulence set up in a pumped well may cause difficulties in the use of float operated recorders. If there is insufficient room in the existing borehole for a float, then the possibility of using other methods including pressure transducers and pneumatic methods should be investigated.

Chart recorders produce a continuous line upon a paper or plasticized chart. The chart itself is graduated, or pre-printed, to facilitate reading of times and levels.

Punched tape recorders produce a set of point readings at regular intervals by punching a series of holes in a paper or plasticized tape. Normally, readings are at 15 min intervals, it is possible to record at 5 min intervals but shorter periods are not available on current instruments.

All recorders require charts or tapes to be changed periodically and batteries may also need replacement. The chart or tape should be clearly marked at the start and finish with the time, date and water level. In addition, the location of the observation and the test well should also be marked.

Check water levels should be obtained using a borehole dipper or a hook gauge on the stilling well

of a weir tank.

If the chart drive rate or interval time is changed during a test, then a new chart or tape should be used, otherwise this can lead to confusion in subsequent interpretation.

The punched tape recorder is not as suitable for on-site operational records as the chart recorder. Level values from the weir tank should be available at intervals similar to those recommended in [Part 3/Sec 4](#) of this standard, with a resolution of 1 min. The advantage of a punched tape recorder is the ease of subsequent analysis which has to be undertaken by computer.

3.2 Manual Water Level Measuring Devices

The normal ‘dipper’ instrument relies upon an electrical circuit which is completed when a slim electrode makes contact with the water. Modern dippers employ a twin cable in the form of flat tape with the cables embedded in the tape edges. Flat tapes are usually graduated at 1 cm or 0.5 cm intervals, but care should be taken in case the tape has been shortened after being repaired or lengthened due to stretching.

Electrical dippers are invariably battery powered, and provide a surface signal visually by a light or a meter needle, or audibly by a buzzer. On a noisy site, the buzzer may be difficult to hear.

3.3 Shaft Encoders

Shaft encoders are available which produce a digital output from a float and counterweight system similar to that in a chart recorder. Encoders with an accuracy of 1 mm are available.

3.4 Transducers

Instead of float operated recorders, strain gauge transducers can be used. The disadvantage of most transducers which work on the strain gauge principle is their accuracy over a limited range. Since pumping tests may involve changes in water level of 25 m, and occasionally more, the attainable accuracy of the order of 0.25 percent is inadequate.

However, where expected depressions in water level are small, the transducer can provide a useful, continuous record. Transducers require calibration prior to the start of the test and special electronic recording equipment should be made available.

Transducers using quartz crystals are available which are sufficiently accurate for many purposes over a wide range of pressures, but they are too expensive for most applications. Strain gauge

transducers measure pressure relative to a reference value. Usually this is either atmospheric pressure with the transducer measuring gauge pressure, or it is an evacuated chamber with the transducer measuring absolute pressure. The type in use should be ascertained. Transducers reading gauge pressure are vented to the atmosphere, usually through the cable. Kinking or trapping of the cable, or exposure of a length of cable to temperature changes, like that caused by coiling in sunlight, can cause a back pressure to develop on the transducer diaphragm which is likely to affect measurement. If there is doubt, and especially where measurement is to be carried out over lengthy periods, non-vented transducers have been found to be generally reliable but these require correction for barometric pressure which should be recorded separately.

3.5 Recording Digital Information

Data loggers are available for recording digital information from either shaft encoders or transducers. These are sealed solid state units requiring battery changes every few years and interrogated by computers.

Information can be logged at different time intervals or according to a variable scheme. A better alternative is event-based logging where a reading is sampled at intervals and only stored in memory if it differs from the previous stored value by more than a set amount.

3.6 Measurements in Overflowing Wells

Heads in overflowing wells can be measured by a manometer fitted to the well head, or, if the pressure head reaches only to a short distance above ground level, a standpipe can be attached. It is important to allow sufficient time for levels in standpipes to stabilize, and to recognize their sensitivity to the opening and closing of adjacent overflowing wells as well as to fluctuations in barometric pressure. For high pressures or for continuous recording of pressure the use of transducers and chart recorders of recording pressure gauges may be necessary.

4 MEASUREMENT OF DISCHARGE

4.1 Weir Tanks

Accuracy of discharge measurements is of prime importance in the subsequent calculations of borehole and aquifer performance.

The most common method of measuring pump discharge is to use a weir tank, with the water discharging over a V-notch or a rectangular notch (see [Fig. 1](#) and [Fig. 2](#)). IS 9108 describes methods for the measurement of water flow using such thin plate weirs.

The discharge over thin plate weirs is a function of the head of the weir, the size and shape of the discharge area, and an experimentally determined coefficient which takes into account the head on the weir, the geometrical properties of the weir and the approach channel and the dynamic properties of water.

4.2 Other Methods

Other means of measuring pump discharge are available and reference should be made to them. One of the methods is by use of orifice weirs [see IS 2952 (Part 2)], however, this method is not applicable where piston pumps are used

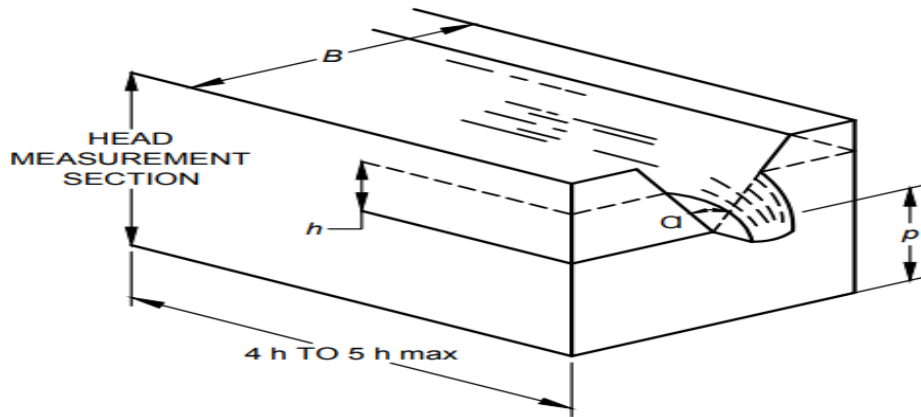

FIG. 1 V-NOTCH THIN-PLATE WEIR

Key

- a = notch angle, that is angle included between the sides of the notch;
- b = width of the approach channel;
- h = measured head; and
- p = height of the vertex of the notch with respect to the floor of the approach channel

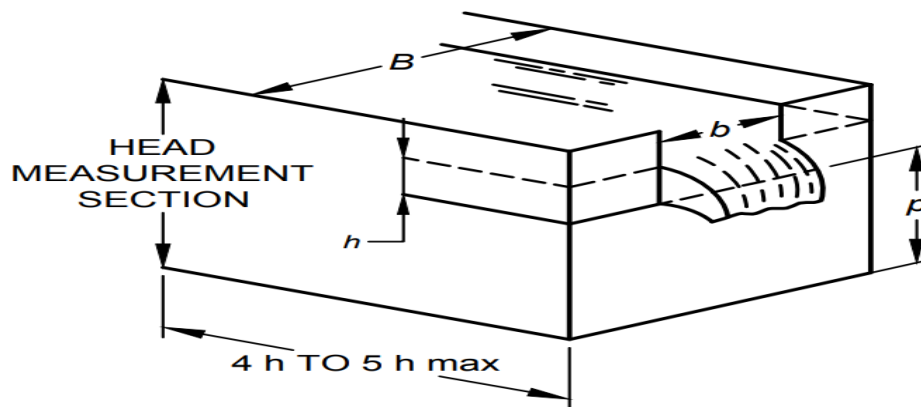

FIG. 2 RECTANGULAR NOTCH, THIN-PLATE WEIR

Key

- b = measured width of the notch;
- B = width of the approach channel;
- h = measured head; and
- p = height of the crest relative to the floor.

*Indian Standard***PUMPING TEST OF WATER WELLS — CODE OF PRACTICE****PART 9 WELL DEVELOPMENT***(First Revision)***1 SCOPE**

This standard (Part 9) lays down guidelines for well development.

2 GENERAL

2.1 The correct development of a well results in improved yield as a result of the removal of material that would otherwise hinder the inflow of water. The process of drilling wells by methods currently in use breaks down all or part of the strata into discrete particles which have to be removed. When drilling fluids are employed these particles are circulated in suspension. As the fluid passes over the wall of the well the particles tend to adhere to, or pass into the wall, a process that is enhanced by the hydrostatic pressure exerted by the drilling fluid. The result is a facing of slurry on the wall, commonly called a wall-cake. In the case of fissures or large intergranular interstices the slurry may penetrate some distance into the aquifer. The first purpose of development is to disperse and remove this slurry together with any loose aquifer material. The test pumping of an undeveloped well is not desirable since the well efficiency can be greatly impaired by failure to remove the slurry. It is possible for the yield to be so low and the drawdown so great that the aquifer is wrongly discounted as a groundwater resource.

Wells constructed in hard rocks such as granite, indurated sandstones or massive crystalline lime stones, generally stand without support and are left open through the water yielding section. Development is usually confined to physical methods.

In soft lime stones, such as chalk, wells will commonly stand without support. However, surging can cause palling of rock from the wall, and the aquifer is usually too soft to shatter readily under the shock of explosives. The normal method of development in such strata is treatment with hydrochloric acid.

Wells in fissured rock often present special problems. Frequently the aquifer consists largely of impervious rock relying for its storage on fissures. These fissures may contain deposits of mineral salts, sand, clay, etc. Care should be taken to avoid over pumping such aquifers, particularly during the development of a well, as flow velocities through the

fissures may otherwise be so high as to result in an undesirable high rate of removal of solids from fissures, giving rise to a high level of suspended solids or dissolved solids in the pumped water. However, development pumping rates should normally exceed the test pumping rate in order to remove as much of the loose aquifer material as is practical in order to ensure clean water when test pumping commences.

In unconsolidated intergranular aquifers the rock or soil consists of a number of grains of varying size. The development of the well causes the finer of these grains to be drawn into the well, and the aquifer is left with an improved hydraulic conductivity in the immediate vicinity of the well.

Wells in unconsolidated sand or gravel are normally fitted with screens and filter packs. Development is physical, often with the addition of deflocculants to assist in breaking down the wall cake.

3 EQUIPMENT FOR WELL DEVELOPMENT

Owing to the necessity of pumping water with a high content of suspended solids, together with the possibility of initial large drawdowns, the choice of pumps for well development is limited. In practice two types are generally used.

The first type is the centrifugal or turbine pump, driven either by a submersible electric motor or by a surface mounted engine rotating a long drive shaft passing through the rising main (a spindle pump). In either case it is possible to control the discharge rate, either by a valve on the rising main or by varying the power supplied to the engine. It is generally not advisable to develop a well with the pump intended for operational use since the inevitable passage of suspended solids can damage the pump impellers with subsequent deterioration of performance. Multistage submersible turbine pumps generally rely on payload liquid lubrication for the inter stage bearing, so care should be taken to avoid loss of pump priming otherwise the pump may be seriously damaged.

The second type of pump is the airlift. With this, the compressed air is forced down in the air pipe from the surface and aerates water within the bottom of the rising main. The aerated water is forced up to the rising main by the pressure of the surrounding unaerated water. [Fig. 1](#) shows the typical detail of

such an arrangement. The depth of submergence of the air pipe, and thus the depth of the well, is critical. Submergence is defined as the depth of the foot of the airpipe beneath the water surface, and the total lift desired is measured upwards from the same surface.

The required percentage of submergence is calculated from the equation:

$$\text{Percentage submergence} = \frac{\text{Submergence}}{\text{Submergence} + \text{Total Lift}} \times 100$$

Values for percentage of submergence may be determined from [Fig. 2](#). Where possible, the values dictated by the curve for minimum optimum submergence should be used. Where a skillful operator is available, reasonable results during development may be obtained with values between the two curves. Where chemical analysis of the pump water is important, an airlift pump should not be used since aeration causes in some chemical characteristics.

4 DEVELOPMENT METHODS

4.1 General

There are many ways in which a well can be developed, and new methods are being sought. Methods commonly used are described in [4.2](#) to [4.6](#).

4.2 Surging

The principle of surging is to cause water flow repeatedly in and out of the well, causing the finer grains within the aquifer, or the material clogging the fissures, to be worked into the well from which they

can be removed. This water movement may need to be vigorous to be successful. Simple pumping of the well for a period of time produces little turbulence and causes the water to flow in only one direction; development may take place but very slowly.

The use of a bailer is limited by the low rate at which water can be discharged, although considerable turbulence can be induced. Where yields exceeding 0.5l/s are required, the use of a bailer for development is not recommended.

Intermittent pumping, with water washing back through the rising main when the pump is stopped, is effective for many low-yield wells. In favorable circumstances, when the wall-cake is less cohesive, wells can be developed readily upto 10 l/s by this method. However, caution should be used when employing electric submersible pumps because the number of starts in a given time could exceed that for which the switch gear is designed. Where an airlift pump can be used, it has considerable advantages in this respect.

Where more vigorous surging is required, surge blocks or plungers should be used and worked as pistons within the lining tubes, however, they should not be operated within an open hole or a screen. An alternative to surge blocks, where the well can be sealed, is to use compressed air to depress the water level, and then to release the pressure to allow a rapid and powerful in flow to the well. The effects of surging can be enhanced by introducing a solution of sodium polyphosphate into the well as a deflocculant. To make the solution, one-part dry mass dissolved into 100 to 200 parts of water is recommended; sufficient solution should be used to displace all the water in the well.

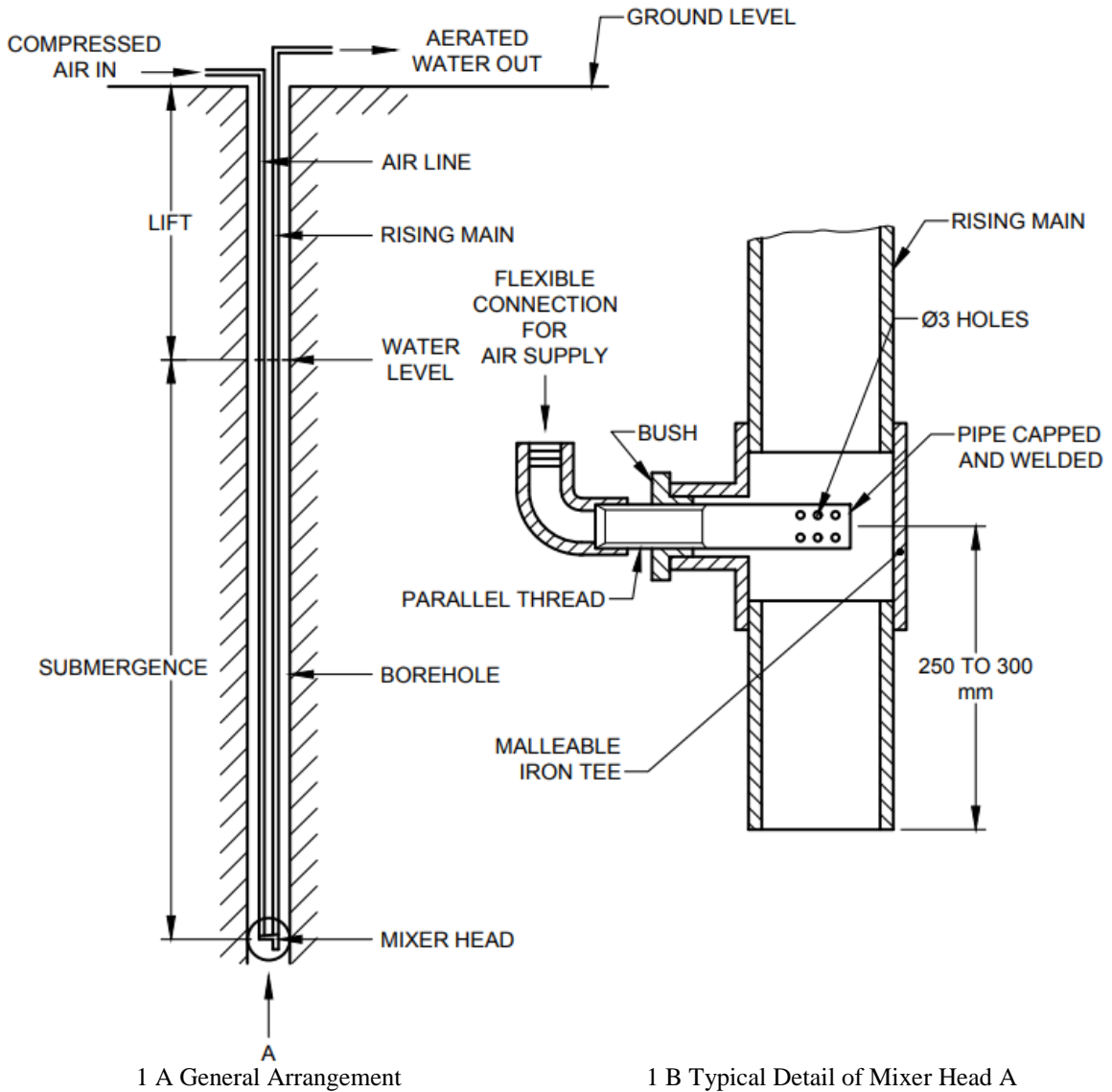

1 A General Arrangement

1 B Typical Detail of Mixer Head A

All dimensions in millimetres.

FIG. 1 CONFIGURATION OF AIRLIFT PUMP IN BOREHOLE

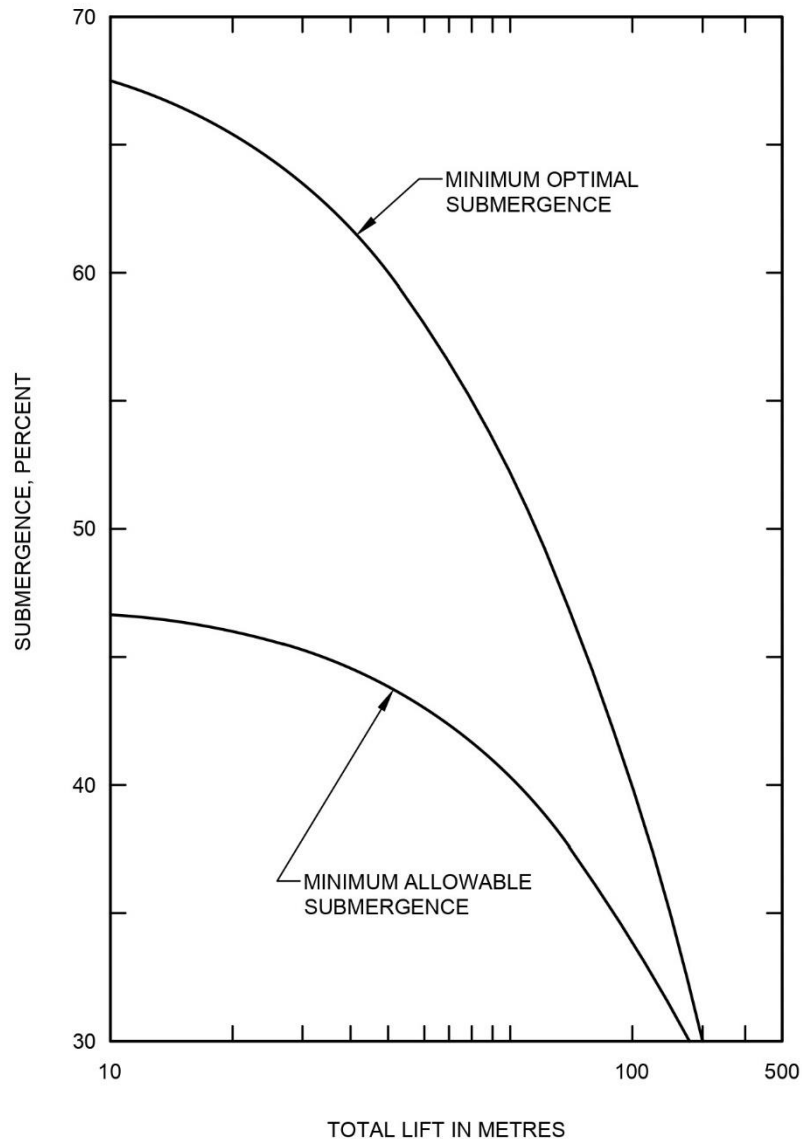

FIG. 2 DEGREE OF SUBMERGENCE REQUIRED FOR AIRLIFT PUMPS

4.3 Jetting

Jetting employs the use of fine water jets directed radially at a minimum velocity of 30 m/s. The use of jetting in open holes should be undertaken with caution as the action is very vigorous. Where the jets can gain free passage through the slots, this method can be very successful in screened wells. The disadvantages are that a substantial source of clean water is necessary and that considerable pumping power is required to obtain adequate jet velocities.

4.4 The Use of Explosives

In hard rocks, failure to intersect fissures may result in little or no yield. In order to establish a hydraulic connection with any nearby fissures, an explosive charge or charges can be detonated in the lower part

of the well so as to shatter the rock. This method of development is relatively inexpensive, can be effective, and when properly used should not seriously damage the well. Soft rocks (such as chalk) tend to cushion the shock wave with little shattering and the method is less successful. Expert assistance is essential when using explosives.

4.5 Acid Treatment

Acid treatment is most useful in soft lime stones such as chalk, where the slurry consists mainly of calcium carbonate and where numerous small fissures are present which allow the acid to penetrate under pressure. The well casing should reach below the water surface in the well, and should be firmly secured with grout. A safety valve should be fitted at the well head to release excess pressure. All

pressure lines and related connections should be pressure tested before operations commence. Pumps and pipelines through which acid is handled, should be thoroughly washed out with water upon completion of operations. It may be advisable to temporarily cap nearby observation wells during acid treatment.

Hydrochloric acid is used, normally in a strength of 29.4 percent (v/v) hydrogen chloride. The commended maximum quantity of acid is 200 kg per square meter of rock exposed in the well. Smaller quantities may be appropriate for the treatment of small wells. The acid should be injected as a single charge, and the well capped off to build up pressure. The safety valve should be set to a value not exceeding 40,000 kg/m², depending upon the condition of the well lining, the grout seal and the well cap. A pressure gauge, fitted to the well cap, will indicate when pressure is lost, for example, as the fissures are cleared.

After acid treatment is completed, the well should be cleaned either by pumping or bailing, and the discharge liquor deposited in a nearby ponded area for final neutralization, where necessary, with slaked lime.

Acid treatment can be hazardous if improperly performed, and should only be carried out by experienced operators.

Personnel handling acids should be equipped with protective clothing including hoods, boots, gloves and goggles. When acid is in use, no person other than the crew directly employed should be allowed in the vicinity, in the event of an accident with acid, first aid treatment should be carried out immediately.

The contents of carboys and other containers should be clearly indicated by proper labelling. A quantity of lime should be made available and utilized to neutralize any acid spilled.

Smoking during acid handling operations should be strictly prohibited. No naked light or other source of ignition should be allowed in the vicinity. Notices to this effect should be prominently displayed.

This acid treatment is recommended only in wells where the borehole is necked. In a cased deep well where mild steel structures are used this treatment is not recommended as the acid may cause corrosion to the slotted operation of the metallic structure, in such structures instead of acid treatment, treatment of sodium hexametaphosphate is recommended.

This treatment is not recommended in all wells. It is recommended only where the expected yield is not obtained due to presence of fine silt or any other

particle which may cause clogging of the aquifer. This is recommended as the last attempt to increase the well yield.

4.6 Compressed Air

As shown in [Fig. 3](#) the volume of water (A) in the education line is taken out by compressed air. The partial vacuum created in the education line is compensated by the stored water in the well by lowering S.W.L. and by formation water.

The formation water carries the loose and foreign particles present in the aquifer to the well and in turn comes out with compressed air.

This is an effective method of development up to a certain degree.

5 PROCEDURE

Development of boreholes by physical means should always commence with caution. Pumping should commence at a low rate, and the drawdown in the well should be measured at frequent intervals as the water level drops. A large drawdown at the start of development may result in excessive amount of solids being drawn into the well and, particularly in chalk boreholes, cause serious spalling of the well wall if it is unlined. In unlined wells, pumping and surging should initially be gentle until the stability of the well wall is established. In screened wells, gentle surging results in the deliberate collapse of the aquifer on to the filter pack (if present) and the screen. If this collapse occurs too suddenly and too violently, the screen can be badly damaged. Continuous sounding should be undertaken to ensure that the well does not fill with debris. This is particularly important in the case of screened wells. If surging continues after the screen length is tilled with debris, damage to the screen, the lining tubes and the surging equipment can be extensive. It is not possible to be precise about what constitutes a large initial drawdown for well development, however it is recommended that the initial pumping rate should be regulated to limit the drawdown to between 2 m and 3 m.

As development continues, the surging can become more vigorous and the pumping rates higher. If the well is developing satisfactorily, the drawdown will decrease gradually for the same pumping rate. When this is observed, and the chemical properties are not significantly changing, the pumping rate can be increased. At this stage a large drawdown can be accepted. In this manner the well may be developed in stages to its full intended output. Development should be continued until the water is clean, and either no further yield can be obtained or until a yield at least 25 percent above the expected operating rate is attained.

Where wells have been treated with acid and cleaned by bailing, a short period of pumping should be done to ensure that all traces of the acid residue have been cleared. This can be indicated by a simple well head titration for chlorides which should not exceed background counts by more than 50 mg/l.

6 MONITORING OF WELL DEVELOPMENT

6.1 General

During development of a well a number of changes will occur in the pumped water. If these changes are carefully monitored, they provide useful information on the effectiveness of the development of the well and on the suitability of the pumping site.

6.2 Changes in Groundwater Quality

The fluid contained in the well at the start of development is a mixture of groundwater and drilling fluid. As development proceeds and water is pumped from the well, the quality of the discharged water may change. Simple monitoring, such as periodical measurement of fluid conductivity, is recommended. Should the mineral content of the groundwater rise significantly and remain at a high level, a decision as to the future potential of the well as a source of useful groundwater may be called for.

6.3 Changes in Content of Suspended Solids

Physical appearance and suspended solids content can be important indicators of the suitability of pumping rate. The content of suspended solids

normally decreases during the development process.

However, there are occasions when the concentration does not decrease, but rather increases, like when fine running sands are encountered. If continued ingress of sand is experienced, the quantity should be measured against time. If the volume of sand remains constant or increases, there may be an attendant risk of collapse of the aquifer. In these circumstances, a decision should be taken either to develop the well to a lesser yield or to abandon the site.

Wells in chalk tend to give a milky discharge on commencement of pumping, and pumping rate should not be increased until the discharge runs clear.

Mineral salts often form a precipitate on contact with air, so that the discharge, initially clear, becomes clouded with suspended matter. The amount of precipitate is a useful indicator of change in the mineral salt content. A discharge that is immediately cloudy when pumped from a fissure-flow aquifer is an immediate warning to monitor the pumping rate.

When pumping from sedimentary rock, the sudden appearance of organic matter in suspension, often coupled with a sudden change in pH, will indicate that a lens of organic deposit is present. It is not desirable that such a lens should leach out at a high rate as this can seriously affect the water quality. Increase in pumping rate should be stopped, and from then onward the organic content should be monitored at frequent interval.

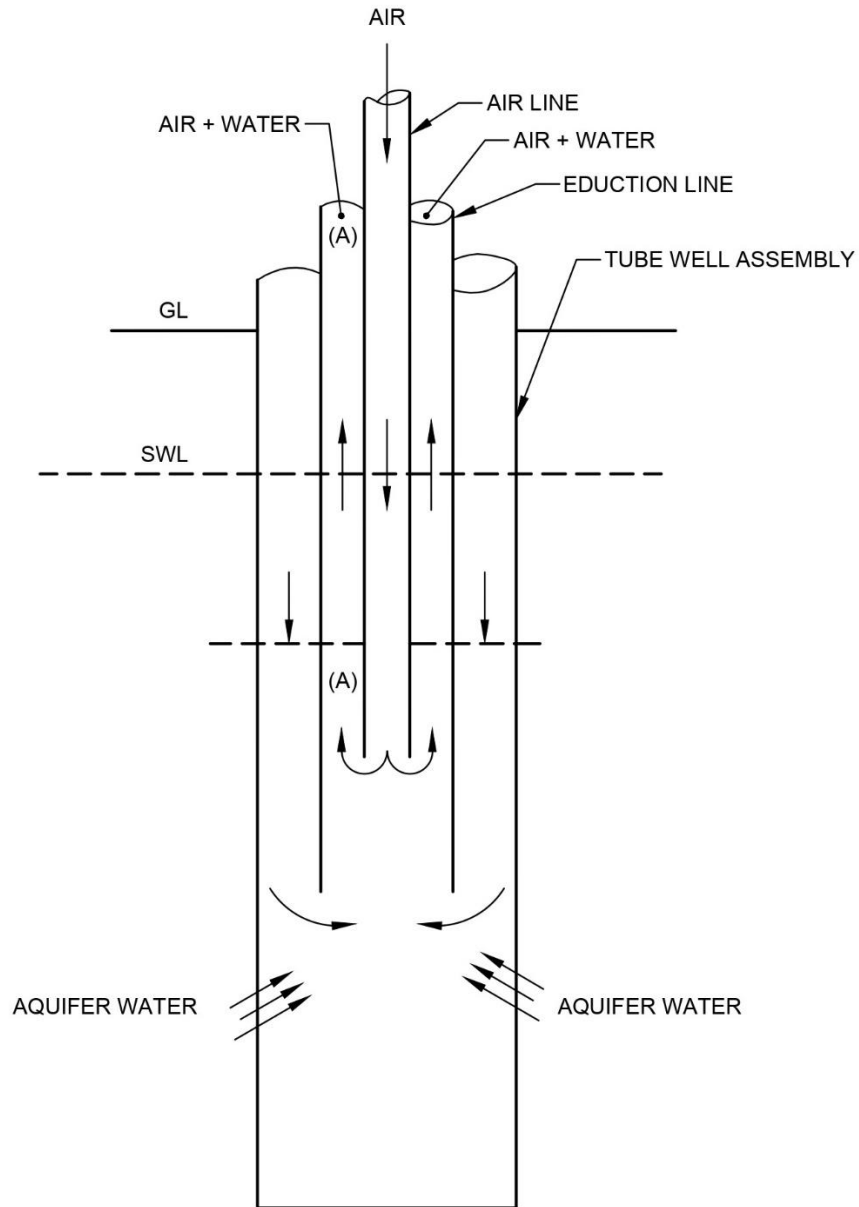

FIG. 3 DEVELOPMENT OF COMPRESSED AIR

ANNEX B

(Foreword)

COMMITTEE COMPOSITION

Ground Water and Related Investigations Sectional Committee, WRD 03

<i>Organization</i>	<i>Representative(s)</i>
Central Ground Water Board, Faridabad	DR A. SUBBURAJ (<i>Chairperson</i>)
Central Electricity Authority, New Delhi	SHRI BALWAN KUMAR SHRIMATI ARPITA UPADHYAY (<i>Alternate</i>)
Central Ground Water Board, Faridabad	SHRI SANJEEV MEHROTRA
Central Pollution Control Board, New Delhi	SHRIMATI SUNITI PARASHAR
Central Water Commission, New Delhi	SHRI AJAY KUMAR SHRI VIMAL KUMAR (<i>Alternate</i>)
Central Water and Power Research Station, Pune	DR MANDIRA MAJUMDER SHRI B. SURESH KUMAR (<i>Alternate I</i>) SHRI G. A. PANVALKAR (<i>Alternate II</i>)
Centre for Water Resources Development and Management, Kozikode	SHRI PRIJU C. P. DR ARUN P. R. (<i>Alternate</i>)
CSIR - National Geophysical Research Institute, Hyderabad	DR M. J. NANDAN
G B Pant Institute of Himalayan Environment and Development, Almora	ER VAIBHAV EKNATH GOSAVI
Geological Survey of India, New Delhi	SHRI SANTOSH KUMAR TRIPATHI SHRI SANJEEV SHARMA (<i>Alternate</i>)
Ground Water Surveys and Development Agency, Pune	SHRI VIJAY PAKHMODE
Gujarat Engineering Research Institute, Vadodara	SHRI N. R. MAKWANA SHRI R. K. CHAUHAN (<i>Alternate</i>)
Gujarat Water Supply and Sewerage Board, Gandhinagar	SHRI NARESH GOR SHRI ROHIT LALJIBHAI CHAUDHARI (<i>Alternate</i>)
ICAR - Central Soil Salinity Research Institute, Karnal	DR M. J. KALEDHONKAR
ICAR - Indian Institute of Soil and Water Conservation, Dehradun	DR P. R. OJASVI DR SHAKIR ALI (<i>Alternate</i>)
National Hydroelectric Power Corporation, Faridabad	SHRI B. P. YADAV MS HEMLATA (<i>Alternate</i>)
Indian Institute of Technology Roorkee, Roorkee	PROF DEEPAK KHARE PROF BRIJESH KUMAR (<i>Alternate</i>)
Irrigation Department Government of Punjab, Chandigarh	SHRI VIJAY KUMAR GARG SHRI TUSHAR GOYAL (<i>Alternate</i>)

<i>Organization</i>	<i>Representative(s)</i>
Irrigation Department Government of Uttarakhand, Dehradun	SHRI DINESH CHANDRA SHRI SHANKAR KUMAR SAHA (<i>Alternate</i>)
Ministry of Environment Forest and Climate Change, New Delhi	SHRI YOGENDRA PAL SINGH SHRI SAURABH UPADHYAY (<i>Alternate I</i>) SHRI SOURABH KUMAR (<i>Alternate II</i>) DR SONU SINGH (<i>Alternate III</i>)
National Bank For Agriculture and Rural Development, Mumbai	SHRI N. V. BASKARAN
National Hydroelectric Power Corporation, Faridabad	SHRI SHYAM LAL KAPIL SHRI VACHASPATI PANDEY (<i>Alternate I</i>) SHRI VIPUL NAGAR (<i>Alternate II</i>)
National Institute of Hydrology, Roorkee	DR ANUPAMA SHARMA
National Remote Sensing Centre, Hyderabad	DR I. C. DAS DR BIDYUT KUMAR BHADRA (<i>Alternate</i>)
North Eastern Regional Institute of Water and Land Management, Tezpur	DR AMULYA CHANDRA DEBNATH DR UZZAL MANI HAZARIKA (<i>Alternate</i>)
Tamil Nadu Water Supply and Drainage Board, Chennai	ENGINEERING DIRECTOR SENIOR HYDROGEOLOGIST (<i>Alternate</i>)
Water Resources Department, Government of Maharashtra, Nashik	SHRI B. J. GADE SHRI M. R. AWALAGNOKAR (<i>Alternate</i>)
In Personal Capacity (<i>House No. 1, New Campus I.I.T. Delhi, Hauz Khas, New Delhi - 110016</i>)	DR A. K. KESARI
In Personal Capacity (<i>Flat No. 1503, Tower 7A, Suncity Parikarma Sector 20 Panchkula - 134116</i>)	SHRI SANAJY MARWAHA
BIS Director General	SHRI R. BHANU PRAKASH, SCIENTIST 'E'/ DIRECTOR AND HEAD (WATER RESOURCES) [REPRESENTING DIRECTOR GENERAL (<i>Ex-officio</i>)]

Member Secretary
SHRI AJAY MEENA
SCIENTIST 'B'/ASSISTANT DIRECTOR
(WATER RESOURCES), BIS

(Continued from second cover)

Part 3 Pretest planning, Section 2 Test design
Part 3 Pretest planning, Section 3 Observation wells
Part 3 Pretest planning, Section 4 Testwells
Part 4 Pretest observations
Part 5 Pumping test
Part 6 Special test
Part 7 Posttest observation of data
Part 8 Water level and discharge measuring device
Part 9 Well development

For the purpose of deciding whether a particular requirement of this standard is complied with, the final value, observed or calculated, expressing the result of a test or analysis, shall be rounded off in accordance with IS 2 : 2022 'Rules for rounding off numerical values (*second revision*)'. The number of significant places retained in the rounded off value should be the same as that of the specified value in this standard.

Bureau of Indian Standards

BIS is a statutory institution established under the *Bureau of Indian Standards Act, 2016* to promote harmonious development of the activities of standardization, marking and quality certification of goods and attending to connected matters in the country.

Copyright

BIS has the copyright of all its publications. No part of these publications may be reproduced in any form without the prior permission in writing of BIS. This does not preclude the free use, in the course of implementing the standard, of necessary details, such as symbols and sizes, type or grade designations. Enquiries relating to copyright be addressed to the Head (Publication & Sales), BIS.

Review of Indian Standards

Amendments are issued to standards as the need arises on the basis of comments. Standards are also reviewed periodically; a standard along with amendments is reaffirmed when such review indicates that no changes are needed; if the review indicates that changes are needed, it is taken up for revision. Users of Indian Standards should ascertain that they are in possession of the latest amendments or edition by referring to the website-www.bis.gov.in or www.standardsbis.in.

This Indian Standard has been developed from Doc No.: WRD 03 (16962).

Amendments Issued Since Publication

Amend No.	Date of Issue	Text Affected

BUREAU OF INDIAN STANDARDS

Headquarters:

Manak Bhavan, 9 Bahadur Shah Zafar Marg, New Delhi 110002

Telephones: 2323 0131, 2323 3375, 2323 9402

Website: www.bis.gov.in

Regional Offices:

	Telephones
Central : 601/A, Konnectus Tower -1, 6 th Floor, DMRC Building, Bhavbhuti Marg, New Delhi 110002	{ 2323 7617
Eastern : 8 th Floor, Plot No 7/7 & 7/8, CP Block, Sector V, Salt Lake, Kolkata, West Bengal 700091	{ 2367 0012 2320 9474
Northern : Plot No. 4-A, Sector 27-B, Madhya Marg, Chandigarh 160019	{ 265 9930
Southern : C.I.T. Campus, IV Cross Road, Taramani, Chennai 600113	{ 2254 1442 2254 1216
Western : 5 th Floor/MTNL CETTM, Technology Street, Hiranandani Gardens, Powai, Mumbai 400076	{ 25700030 25702715

Branches : AHMEDABAD, BENGALURU, BHOPAL, BHUBANESHWAR, CHANDIGARH, CHENNAI, COIMBATORE, DEHRADUN, DELHI, FARIDABAD, GHAZIABAD, GUWAHATI, HARYANA (CHANDIGARH), HUBLI, HYDERABAD, JAIPUR, JAMMU, JAMSHEDPUR, KOCHI, KOLKATA, LUCKNOW, MADURAI, MUMBAI, NAGPUR, NOIDA, PARWANOO, PATNA, PUNE, RAIPUR, RAJKOT, SURAT, VIJAYAWADA.