

बंद वाहिकाओं में द्रव प्रवाह मापन —
पिटोट स्टैटिक ट्यूब द्वारा वेग क्षेत्र पद्धति
(दूसरा पुनरीक्षण)

**Measurement of Fluid Flow in Closed
Conduits — Velocity Area Method
Using Pitot Static Tube**
(*Second Revision*)

ICS 17.120.10

© BIS 2024
© ISO 2020



भारतीय मानक ब्यूरो
BUREAU OF INDIAN STANDARDS
मानक भवन, 9 बहादुर शाह ज़फर मार्ग, नई दिल्ली - 110002
MANAK BHAVAN, 9 BAHADUR SHAH ZAFAR MARG
NEW DELHI - 110002
www.bis.gov.in www.standardsbis.in

NATIONAL FOREWORD

This Indian Standard (Second Revision) which is identical to ISO 3966 : 2020 'Measurement of fluid flow in closed conduits — Velocity area method using Pitot static tubes' issued by the International Organization for Standardization (ISO) was adopted by the Bureau of Indian Standards on recommendation of the Hydrometry Sectional Committee and approval of the Water Resources Division Council.

This standard was first published in 2001 which was identical to ISO 3966 : 1977. The first revision of this standard was undertaken in 2019 to align it with the then latest version of ISO 3966 : 2008. This second revision of this standard has been brought out to align it with the latest version of ISO 3966 : 2020.

The text of ISO standard has been considered as suitable for publication as an Indian Standard without deviations. Certain conventions and terminologies are, however, not identical to those used in Indian Standards. Attention is particularly drawn to the following:

- a) Wherever the words 'International Standard' appear referring to this standard, they should be read as 'Indian Standard'; and
- b) Comma (,) has been used as a decimal marker, while in Indian Standards, the current practice is to use a point (.) as the decimal marker.

The Committee has reviewed the provisions of the following International Standards referred in this adopted standard and has decided that they are acceptable for use in conjunction with this standard:

<i>International Standard</i>	<i>Title</i>
ISO 2186	Fluid flow in closed conduits — Connections for pressure signal transmissions between primary and secondary elements
ISO 7194	Measurement of fluid flow in closed conduits — Velocity-area methods of flow measurement in swirling or asymmetric flow conditions in circular ducts by means of current-meters or Pitot static tubes

For better clarity, 4.2 may be read along with schematic diagram given in **National Annex A.** 

For the purpose of deciding whether a particular requirement of this standard is complied with the final value, observed or calculated expressing the result of a test or analysis shall be rounded off in accordance with IS 2 : 2022 'Rules for rounding off numerical values (*second revision*)'. The number of significant places retained in the rounded off value should be the same as that of the specified value in this standard.

Contents

Page

1	Scope	1
2	Normative references	1
3	Terms, definitions and symbols	1
3.1	Terms and definitions.....	1
3.2	Symbols.....	2
4	Principle	3
4.1	General principle.....	3
4.1.1	Graphical integration of the velocity area (see Clause 9).....	4
4.1.2	Numerical integration of the velocity area (see Clause 10).....	4
4.1.3	Arithmetical methods (see Clause 11).....	4
4.2	Measurement of the measuring cross-section.....	4
4.2.1	Circular cross-sections.....	4
4.2.2	Rectangular cross-sections.....	4
4.3	Measurement of local velocities.....	5
4.3.1	Method of exploring traverse section.....	5
4.3.2	Reference measurement.....	5
4.3.3	Checking of velocity distribution.....	5
4.4	Location and number of measuring points in the cross-section.....	6
4.4.1	General requirements.....	6
4.4.2	Circular cross-sections.....	6
4.4.3	Rectangular cross-sections.....	6
5	Design of Pitot tubes	7
5.1	General description.....	7
5.2	Criteria to be fulfilled by the Pitot tube.....	7
6	Requirements for use of Pitot tubes	8
6.1	Selection of the measuring cross-section.....	8
6.1.1	Location of the measuring cross-section (of selection).....	8
6.1.2	Avoidance of asymmetry, swirl and turbulences.....	8
6.1.3	Maximum flow deviation.....	8
6.1.4	Preliminary traverse tests.....	9
6.2	Devices for improving flow conditions.....	9
6.2.1	Anti-swirl device.....	9
6.2.2	Profile developer.....	9
6.2.3	Positioning/Location of devices.....	9
6.2.4	Provisional guiding installation.....	9
6.3	Limits of use.....	9
6.3.1	Nature of the fluid.....	9
6.3.2	Range of velocities.....	9
6.3.3	Nature of the flow.....	10
6.3.4	Dimensional limitations.....	10
6.3.5	Influence of turbulence.....	10
6.4	Performance of measurements.....	10
6.4.1	Measurement of differential pressure.....	10
6.4.2	Differential pressure fluctuations.....	10
6.4.3	Determination of fluid density.....	11
6.5	Inspection and maintenance of the Pitot tube.....	11
7	Positioning of Pitot tube	11
8	Velocity computation	11
8.1	Verification of conditions for a measurement.....	11
8.2	Formulae for velocity computation.....	12

9	Determination of the discharge velocity by graphical integration of the velocity area	13
9.1	Circular cross-section.....	14
9.2	Rectangular cross-sections.....	15
10	Determination of the discharge velocity by numerical integration of the velocity area	17
10.1	Circular cross-sections.....	17
10.2	Rectangular cross-sections.....	19
11	Determination of the discharge velocity by arithmetic methods	19
11.1	“Log-linear” method.....	20
11.1.1	Circular cross-sections.....	20
11.1.2	Rectangular cross-sections.....	20
11.2	Log-Chebyshev method.....	22
11.2.1	Circular cross-sections.....	22
11.2.2	Rectangular cross-sections.....	22
12	Corrections of local velocity measurements	23
12.1	Correction for stem blockage.....	23
12.1.1	Case where the correction can be neglected.....	23
12.1.2	Estimation of the correction of local velocity measurement.....	23
12.1.3	Estimation of the overall correction of the flow-rate value (application to arithmetic methods).....	25
12.2	Correction for transverse velocity gradient.....	25
12.2.1	Correction for measuring point position.....	26
12.2.2	Overall correction of flow rate.....	26
12.3	Correction for turbulence.....	27
12.4	Correction for head loss.....	28
13	Errors	28
13.1	Definition of the error.....	28
13.2	Errors in the estimation of the local velocity.....	28
13.2.1	Random errors.....	28
13.2.2	Systematic errors.....	29
13.3	Errors in the estimation of flow rate.....	30
13.3.1	Random errors.....	30
13.3.2	Systematic errors.....	30
13.4	Definition of the standard deviation.....	31
13.5	Definition of the tolerance.....	31
13.6	Calculation of standard deviation.....	32
13.6.1	Standard deviation on local velocity measurement.....	32
13.6.2	Standard deviation on flow-rate measurement.....	33
Annex A (normative) Pitot tubes		34
Annex B (normative) Correction to the measuring position of Pitot tubes used in a transverse velocity gradient		40
Annex C (normative) Study concerning turbulence correction		42
Annex D (normative) Damping of pressure gauges		45
Annex E (normative) Measurements with a Pitot tube in a compressible fluid		47
Annex F (normative) Determination of coefficient m for extrapolation near the wall		51
Annex G (informative) Example of calculation of the uncertainty on the flow-rate measurement by means of Pitot tubes		52
Bibliography		55

Indian Standard

MEASUREMENT OF FLUID FLOW IN CLOSED CONDUITS — VELOCITY AREA METHOD USING PITOT STATIC TUBES

(*Second Revision*)

1 Scope

This document specifies a method for the determination in a closed conduit of the volume rate of flow of a regular flow

- a) of a fluid of substantially constant density or corresponding to a Mach number not exceeding 0,25,
- b) with substantially uniform stagnation temperature across the measuring cross-section,
- c) running full in the conduit, and
- d) under steady flow conditions.

In particular, it deals with the technology and maintenance of Pitot static tubes, with the calculation of local velocities from measured differential pressures and with the computation of the flow rate by velocity integration.

2 Normative references

The following documents are referred to in the text in such a way that some or all of their content constitutes requirements of this document. For dated references, only the edition cited applies. For undated references, the latest edition of the referenced document (including any amendments) applies.

ISO 2186, *Fluid flow in closed conduits — Connections for pressure signal transmissions between primary and secondary elements*

3 Terms, definitions and symbols

3.1 Terms and definitions

For the purposes of this document, the following terms and definitions apply.

ISO and IEC maintain terminological databases for use in standardization at the following addresses:

- ISO Online browsing platform: available at <https://www.iso.org/obp>
- IEC Electropedia: available at <http://www.electropedia.org/>

3.1.1

Pitot static tube

"Pitot tube"

tubular device consisting of a cylindrical head attached perpendicularly to a stem allowing measurement of a differential pressure from which the flow rate of the fluid in which it is inserted can be determined, and which is provided with static pressure tapping holes (drilled all around the circumference of the head at one or more cross-sections) and with a total pressure hole (facing the flow direction at the tip of the axially symmetrical nose of the head)

3.1.2

static pressure tapping

group of holes for the measurement of fluid static pressure

3.1.3

total pressure tapping

hole for the measurement of fluid stagnation pressure (the pressure produced by bringing the fluid to rest without change in entropy)

3.1.4

differential pressure

difference between the pressures at the total and static pressure taps

3.1.5

stationary rake

set of Pitot tubes, mounted on one or several fixed supports, which explore the whole diameter or measuring section simultaneously

3.1.6

peripheral flow rate

volume flow rate in the area located between the pipe wall and the contour defined by the velocity measuring points which are the closest to the wall

3.1.7

discharge velocity

ratio of the volume rate of flow (integral of the axial component of local velocities with respect to the cross-sectional area) to the area of the measuring cross-section

3.1.8

relative velocity

ratio of the flow velocity at the considered point to a reference velocity measured at the same time and being either the velocity at a particular point (e.g. the centre of a circular conduit) or the discharge velocity in the measuring section

3.1.9

straight length

conduit section, the axis of which is rectilinear and the surface and cross-section of which are constant

Note 1 to entry: The shape of this section is usually circular, but it may be rectangular or annular.

3.1.10

irregularity

any element or configuration of a conduit which makes it different from a straight length

Note 1 to entry: For the purpose of this document, those irregularities which create the most significant disturbances are bends, valves, gates and sudden widening of the section.

3.2 Symbols

Symbol	Quantity	Dimensions	SI unit
A	cross-sectional area of the conduit	L^2	m^2
a, a'	distance of the extreme measuring point to the nearest wall	L	m
D	pipe diameter	L	m
d	head diameter	L	m
d'	stem diameter	L	m
d_i	total pressure tapping hole diameter	L	m
H	rectangular conduit height	L	m
h	height of a particular point above the bottom	L	m
k_b	blockage coefficient of a cylindrical stem	—	—
k_g	coefficient depending on the nose shape	—	—
k_t	coefficient of turbulence correction	—	—

Symbol	Quantity	Dimensions	SI unit
L	rectangular conduit width	L	m
l	distance from a particular point to the side-wall	L	m
M	molar mass of fluid	M	kg/mol
m	roughness coefficient	—	—
Ma	Mach number	—	—
p	absolute static pressure of the fluid	$ML^{-1}T^{-2}$	Pa
q_V	volume flow rate	L^3T^{-1}	m^3/s
R_g	molar constant of gas	$ML^2T^{-1}\Theta^{-1}$	J/mol·K
R	pipe radius	L	m
r	measuring circle radius	L	m
Re	Reynolds number	—	—
S	frontal projected area of the stem inside the conduit	L^2	m^2
T	absolute temperature	Θ	K
U	discharge velocity	LT^{-1}	m/s
u	mean velocity along a circumference or a measurement line	LT^{-1}	m/s
v	local velocity of the fluid	LT^{-1}	m/s
X	pipe dimension	L	m
y	distance of a measuring point to the wall	L	m
Z	gas law deviation factor	—	—
α	calibration factor of the Pitot tube	—	—
γ	ratio of the specific heat capacities	—	—
Δp	differential pressure measured by the Pitot tube	$ML^{-1}T^{-2}$	Pa
ε	expansibility factor	—	—
$(1 - \varepsilon)$	compressibility correction factor	—	—
λ	universal coefficient for head loss	—	—
μ	dynamic viscosity of the fluid	$ML^{-1}T^{-1}$	Pa·s
ν_{kv}	kinematic viscosity of the fluid	L^2T^{-1}	m^2/s
ξ	head loss	$ML^{-1}T^{-2}$	Pa
ρ	density of the fluid	ML^{-3}	kg/m^3
φ	Pitot tube inclination	—	—

4 Principle

4.1 General principle

The principle of the method consists of:

- measuring the dimensions of the measuring section, which shall be normal to the conduit axis — this measurement is necessary for defining the area of the cross-section (see 4.2);
- defining the position of the measuring points in the cross-section, the number of measuring points having to be sufficient to permit adequate determination of the velocity profile;
- measuring the differential pressure existing between the total and static pressures of the Pitot tube placed at these measuring points (see 4.3) and determining the density of the fluid in the test conditions;
- determining the local velocity of the flow, from given formulae, on the basis of previous measurements (see Clause 8);

- e) determining the discharge velocity from these values;
- f) calculating the volume rate of flow equal to the product of the cross-sectional area and the discharge velocity.

Errors in the techniques described in a) to f) contribute to the error in the flow-rate measurement; other sources of error (such as the shape of the velocity distribution and the number of measuring points) are discussed in [Clause 13](#).

The method of measurement and the requirements defined in this document aim at reaching, at the 95 % confidence level, an uncertainty in flow rate not greater than ± 2 %. To attain this result, it may be necessary, according to measurement conditions, to take into account the corrections given in [Clause 12](#). If any of the requirements of this document are not fulfilled, this method may still be applied in special cases but the uncertainty on flow rate will be larger.

This document presents three types of methods for determining the discharge velocity.

4.1.1 Graphical integration of the velocity area (see [Clause 9](#))

This method consists in plotting the velocity profile on a graph and evaluating the area under the curve which is bounded by the measuring points closest to the wall. To the value thus obtained is added a calculated term which allows for the flow in the peripheral zone (the area between the wall and the curve through the measuring positions closest to the wall) on the assumption that the velocity profile in this zone satisfies a power law.

For this method, the measuring points may be located at whichever positions are required in order to obtain a satisfactory knowledge of the velocity profile.

4.1.2 Numerical integration of the velocity area (see [Clause 10](#))

The difference between this method and [4.1.1](#) lies in the fact that the graphical velocity profile is replaced by an algebraic curve and the integration is carried out analytically.

4.1.3 Arithmetical methods (see [Clause 11](#))

The arithmetical methods assume that the velocity distribution follows a particular law and the mean velocity in the conduit is then given by a linear combination of the individual velocities measured at the locations specified by the method.

For the arithmetical methods described in [Clause 11](#), the assumption is made that in the peripheral zone the velocity distribution follows a logarithmic law as a function of the distance from the wall.

4.2 Measurement of the measuring cross-section

4.2.1 Circular cross-sections

The mean diameter of the conduit is taken as equal to the arithmetic mean of measurements carried out on at least four diameters (including the traverse diameters) at approximately equal angles to each other in the measuring section. Should the difference between the lengths of two consecutive diameters be greater than 0,5 %, the number of measured diameters shall be doubled.

4.2.2 Rectangular cross-sections

The conduit width and height shall both be measured at least on each straight line (at least four) passing through the measuring points. Should the difference between the widths (or heights) corresponding to two successive measuring lines be greater than 1 %, the number of measured widths (or heights) shall be doubled.

4.3 Measurement of local velocities

4.3.1 Method of exploring traverse section

It is sometimes proposed that several Pitot tubes be mounted on a stationary rake in order to explore simultaneously the whole measuring cross-section. However, the experimental data available at the time of publication are insufficient to allow the design of certain details (such as shape of head and of stem) which would ensure that measurements by a rake would achieve the accuracy required by this document.

Therefore, this document deals only with velocity area methods using a single Pitot tube placed successively at each measuring point.

4.3.2 Reference measurement

Reference measurements shall be made in order to check the steadiness of flow and to correct individual velocity measurements for slight changes in flow rate during traversing; any reference measuring device inserted in the conduit shall be placed in such a way that there is no interaction with the traversing Pitot tube. The reference measurement shall be made as far as possible simultaneously with each velocity measurement.

However, if only one measuring device is available, the steadiness of the flow shall be checked by repeating measurements at the reference point after each local velocity measurement.

The shape of the velocity profile in the measuring cross-section shall remain stable and shall not be affected by possible variations of the flow rate whilst measurements are being taken.

When the curve of reference velocity, v_r , has been plotted against time, this curve is used to relate all traverse measurements to the same reference flow rate, q_o (preferably that which corresponds to the mean of velocity measurements at the fixed point). For comparatively small changes of the reference velocity, the velocity, $v_{i,t}$, measured at any point, i at time, t can be transposed by multiplication by the ratio of velocity, $v_{r,o}$, at the reference point corresponding to flow rate, q_o , at velocity, $v_{r,t}$, at this reference point at time t is given by [Formula \(1\)](#):

$$v_{i,o} = v_{i,t} \left(\frac{v_{r,o}}{v_{r,t}} \right) \quad (1)$$

NOTE Where the reference measurement is a quantity directly proportional to the flow rate (e.g. the rotational frequency of a shaft driving a fan or a pump), this measurement can be substituted directly for $v_{r,o}$ and $v_{r,t}$ in the above formula. Where the reference reading is in the form of a pressure difference (e.g. across a fixed feature of the flow circuit, or the differential pressure of a reference Pitot tube), the square root of each reference reading can be substituted for $v_{r,o}$ and $v_{r,t}$ in the above formula.

However, note that velocity profile fluctuations may occur without creating flow rate fluctuations. In such a case, the use of reference point velocity may lead to errors and it is preferable to check steadiness of flow by means of any pressure difference device (standardized pressure difference flow meter, piezometric control on a convergent, bend, spiral casing, peculiar pressure loss, etc.), even if it is not calibrated, provided that its reliability and adequate sensitivity have been ascertained. In this case, the above-mentioned proportional correction relates to the differential pressure and not to the velocity.

4.3.3 Checking of velocity distribution

It is recommended that the regularity of the velocity distribution be checked either by plotting or by other means, regardless of whether or not the plotting is necessary for calculating the discharge velocity.

In the same way, when several measurements are made on the same cross-section at different flow rates, it is recommended that the velocity profiles be plotted in a non-dimensional manner (i.e. by using the relative velocities; see [3.1.8](#)) to check their consistency with each other and hence to ensure that

there are no abnormal features at particular flow rates (thus, the profiles shall not change erratically as the flow rate varies over a wide range of Reynolds numbers).

It may also be useful to plot the velocity distribution curves as indicated above in order to detect any error in the measurement of a local velocity. The doubtful measurement shall be repeated whenever possible; when this cannot be done, it shall be ignored and the velocity profile drawn on the basis of the previously obtained profiles provided there are independent reasons for believing the doubtful measurement is false.

4.4 Location and number of measuring points in the cross-section

4.4.1 General requirements

The rules to be followed for locating the measuring points differ according to the methods of determination of the discharge velocity as specified in this document. These rules are given in [Clauses 9, 10](#) and [11](#), respectively.

Whatever method is used, the distance between the axis of the head of the Pitot tube and the wall shall not be less than the head diameter, d .

The location of the Pitot tube shall be calculated from the actual dimension of the conduit along each traverse line (rather than from the mean dimension) and shall be measured to:

a) $\pm 0,005 \cdot X$, where X is the dimension of the duct parallel to the measurement of the Pitot tube position;

or

b) $\pm 0,05 \cdot y$, where y is the distance of the Pitot tube from the nearest wall, whichever is the smaller.

[4.4.2](#) and [4.4.3](#) specify a minimum number of measuring points applying in particular to small dimension conduits. As it is necessary to define the velocity profile as accurately as possible, the number of measuring points can be advantageously increased provided that this is allowed by the operating conditions and steadiness of the flow.

When a single Pitot tube is traversed across the duct, the distance between a reference point (from which each position is measured) and the wall of the duct shall first be obtained. This may introduce a relatively large systematic error in all position measurements. In such instances, it is recommended that complete diameters be traversed (rather than opposite radii on each diameter) since the systematic error will then tend to cancel out on the two halves of the traverse.

4.4.2 Circular cross-sections

The measuring points shall be located at every point of intersection between a prescribed number of circles concentric with the pipe axis and at least two mutually perpendicular diameters.

The measurements shall be carried out in at least three points per radius, so that there is a minimum of 12 points in the cross-section. An additional measuring point at the centre of the conduit is desirable to check the shape of the velocity profile and is necessary for the calculation of the stem blockage correction, where applicable (see [12.1.2](#)).

4.4.3 Rectangular cross-sections

The minimum number of measuring points shall be 25. Unless a special layout of measuring points is required for the use of an arithmetic method, their position shall be defined by the intersections of at least five straight lines running parallel to each wall of the conduit.

5 Design of Pitot tubes

5.1 General description

The use of one of the types of Pitot tube described in [Annex A](#), all of which fulfil the requirements of [5.2](#), is recommended; this avoids the necessity of making several corrections to the measurements. The use of any other Pitot tube which fulfils the requirements of [5.2](#) is permitted provided that its calibration is known.

The Pitot static tubes dealt with in this document consist of a cylindrical head attached perpendicularly to a stem which usually passes through the wall of a conduit. The length of the head is generally between $15d$ and $25d$, where d is the head diameter.

At one or two cross-sections along the head, static-pressure holes are drilled around the circumference, so that, in the absence of leakage, the registered pressure is transferred through the head and stem to a point outside the conduit.

A smaller tube, concentric with the head and stem, transfers the total pressure, registered by a hole facing the flow direction at the tip of an axially symmetrical nose integral with the head, to a point outside the conduit.

An alignment arm, fitted to the end of the stem, facilitates alignment of the head when this is obscured by the conduit wall.

5.2 Criteria to be fulfilled by the Pitot tube

The nose (including the total pressure hole) shall be designed in such a way as to comply with the following requirements.

- a) The response of the differential pressure to inclination of the head relative to the flow shall meet one of the following two conditions according to the circumstances (in both cases it is necessary to know the response curve of the Pitot tube):
 - 1) if precise alignment of the Pitot tube with the conduit axis is not possible but there is no swirl, the differential pressure should be as independent as possible of the yaw of the head in uniform flow¹⁾;
 - 2) if precise alignment of the Pitot tube with the conduit axis is possible but swirl is present, the variation of the differential pressure recorded by the tube in uniform flow with yaw angle, φ , shall be approximately proportional to $\cos^2\varphi$. If the head is perfectly aligned axially and if swirl is less than $\pm 3^\circ$, the differential pressure shall not deviate from this relationship by more than 1 %.

It should be noted that misalignment and swirl can occur simultaneously and efforts shall be made to minimize each of them.

- b) The calibration factors for different specimens of tubes to a particular specification shall be identical, to within $\pm 0,25$ %, and shall remain so for the working life of any such tube. If the user has any doubt upon this point, an individual calibration of each Pitot tube should be made.
- c) When used in a liquid, any cavitation from the nose shall not cause a significant error in the static pressure reading of the tube.
- d) The static-pressure holes shall be:
 - 1) not larger than 1,6 mm in diameter;

1) The Pitot tubes described in [Annex A](#) allow independence of the differential pressure to within $\pm 1,5$ % up to 14° yaw in uniform flow.

- 2) at least six, and sufficient in number for the damping in the static pressure circuit to be as nearly as possible equal to that in the total-pressure circuit; if necessary, on Pitot tubes the diameter of which is small, the orifices may be placed in two places;
 - 3) placed not less than $6d$ from the tip of the nose;
 - 4) placed not less than $8d$ from the axis of the stem.
- e) If the stem is enlarged to a diameter d' , there shall be a length of stem not less than $7d'$ between the axis of the head and the commencement of the enlargement, for which the stem diameter is equal to the head diameter.
 - f) The junction between the head and stem shall be either mitred or curved to a mean radius equal to $(3 \pm 0,5)d$.
 - g) An alignment arm shall be fitted to the end of the stem away from the head, to ensure precise alignment and positioning within a conduit.

Three types of Pitot tubes which are currently used and which comply with these criteria are described as examples in [Annex A](#).

6 Requirements for use of Pitot tubes

6.1 Selection of the measuring cross-section

6.1.1 Location of the measuring cross-section (of selection)

The cross-section selected for measurement shall be located in straight pipe length and shall be perpendicular to the direction of flow. It shall be of simple shape, e.g. circular, rectangular. It shall be located in an area where the measured velocities fall within the normal working range of the apparatus used (see [6.3.2](#)).

6.1.2 Avoidance of asymmetry, swirl and turbulences

Close to the measuring cross-section, flow shall be substantially parallel to and symmetrical about the conduit axis and contain neither excessive turbulence nor swirl; the measuring cross-section shall thus be chosen far enough away from any disturbances that could create asymmetry, swirl or turbulence (see [6.1.4](#)).

The length of straight pipe that may be required to achieve these conditions will vary with the flow velocity, upstream disturbances, level of turbulence and the degree of swirl, if any²⁾.

6.1.3 Maximum flow deviation

Although measurements with the Pitot tube in oblique or converging flow should as far as possible be avoided, these may, however, be carried out provided that the maximum flow deviation with respect to the Pitot tube axis does not exceed 3° .

For guidance, it can also be considered that a swirl is small enough not to increase the confidence limits given in this document on the measured flow rate if the resulting gradient of local velocities to the pipe axis is less than 3° .

2) For guidance, it is normally assumed that to comply with these conditions there should be a length of upstream conduit between the beginning of the working section and any significant upstream irregularity (see 3.2.10) of at least 20 diameters of a circular cross-section (or 80 times the hydraulic radius of a conduit of any cross-section shape). Similarly there should be at least 5 diameters of a circular cross-section (or 20 times the hydraulic radius of a conduit of any cross-section shape), between the measuring cross-section and any significant downstream irregularity.

6.1.4 Preliminary traverse tests

Preliminary traverse tests shall be made to ascertain the regularity of flow.

If these traverses show that flow is not satisfactory, this can sometimes be remedied using one of the devices described in [6.2](#).

Once these devices are in place, check that the flow complies with the requirements of this document. If not, a more detailed traverse of the measuring cross-section is necessary.

6.2 Devices for improving flow conditions

6.2.1 Anti-swirl device

If swirl is present in the flow, it can often be suppressed by means of an anti-swirl device consisting either of several adjacent pipes parallel to the flow direction or of a honeycomb with square or hexagonal cells. Whichever type is used, the whole device shall be rigorously symmetrical and the following requirements shall be met:

- a) the maximum transverse dimension, a , of a channel shall be less than $0,25 D$, where D is pipe diameter;
- b) length shall be greater than $10 a$.

6.2.2 Profile developer

If the velocity distribution is unacceptably irregular, it can often be remedied by means of a profile developer consisting of, for example, one or more screens, grids or perforated plates. Note, however, that such devices are only effective at the price of a rather high head loss.

6.2.3 Positioning/Location of devices

The devices described in [6.2.1](#) and [6.2.2](#) shall be located at the greatest possible distance upstream of the measuring cross-section and in any case at a distance of at least five diameters of a circular cross-section (or 20 times the hydraulic radius of a conduit of any cross-section shape). Furthermore, they shall not be located immediately downstream of a disturbance.

6.2.4 Provisional guiding installation

If the velocity distribution is unacceptably irregular or if the flow is not parallel enough, but if it has been possible to check that no swirl is present, it is sometimes possible to remedy the situation by means of a provisional guiding installation. The latter consists of a slightly converging entrance, connected in such a way as to ensure that no separation occurs, to a straight pipe length, the length of which shall be at least twice the larger dimension of the conduit.

6.3 Limits of use

6.3.1 Nature of the fluid

The fluid shall be a continuous single-phase fluid or shall behave as if it were such a fluid. Liquids shall be newtonian and shall not exhibit anomalous viscosity or thixotropic behaviour.

6.3.2 Range of velocities

Pitot tubes shall not be used with flow velocities less than the velocity corresponding to the lower limit of the Reynolds number (see [8.1](#)) or greater than the velocity corresponding to a Mach number of 0,25.

6.3.3 Nature of the flow

The expressions given (see [8.1](#) and [8.2](#)) are accurate only for steady flow without transverse velocity gradient or turbulence. In practice, both are always present in closed conduits. [Clause 12](#) and [Annexes B](#) and [C](#) shall give indications of the magnitude of the corresponding errors.

6.3.4 Dimensional limitations

The ratio d/D of the Pitot tube diameter, d , to the conduit diameter D shall not exceed 0,02 with a view to keeping negligible the error on the rate of flow resulting from the velocity gradient and from the stem blockage effect (see [Clause 12](#)). In difficult flow conditions, a ratio of up to 0,04 may be admissible provided that the necessary corrections for blockage effect and velocity gradient are made; this limit value may indeed be necessary to avoid vibration of the tube in very high velocity flows. On the other hand the requirements mentioned in [Clause 5](#) shall be satisfied.

6.3.5 Influence of turbulence

Turbulence has a twofold influence in the case of an exploration by means of a Pitot tube, i.e.:

- a) on the total pressure reading;
- b) on the static pressure reading.

Turbulence of flow leads to an overestimation in the determination of velocity, which is a function of the degree of turbulence.

Detailed study of the turbulence correction is given in [Annex C](#).

6.4 Performance of measurements

6.4.1 Measurement of differential pressure

The device chosen for the measurement of differential pressure shall be capable of measurement of a steady differential pressure equal to the maximum value recorded during the traverse with an uncertainty not exceeding 1 % (at 95 % confidence level).

6.4.2 Differential pressure fluctuations

In order to obtain, from the measurements, time-averaged values which are representative in spite of random fluctuations of the flow rate, it is necessary:

- a) that the differential pressure fluctuations be damped by applying to the measuring apparatus the minimum damping allowing easy reading without concealing longer-term fluctuations — the damping of the apparatus shall be symmetrical and linear; this can be achieved by means of a capillary tube located in the manometric limb in accordance with the requirements of [Annex D](#);
- b) that readings at each measuring point shall be repeated a certain number of times, preferably at unequal time intervals — a sufficient number of readings is reached when suppressing any one of them (except those which present an abnormally high error and are excluded automatically) does not modify the mean by more than ± 1 %.

However, if damping condition a) has been satisfied sufficiently well so that the instantaneous readings of differential pressure do not fluctuate by more than ± 2 % of the mean differential pressure over a sufficiently long period of time (e.g. 10 maximum and 10 minimum values to be observed), then a visual averaging of the measurement is permissible.

NOTE The final tolerance applicable to the rate of flow on account of random fluctuations of the readings will be a function of the total number of readings made during an exploration. Consequently if the total number of measuring points is high, the number of readings at each point can be comparatively small.

6.4.3 Determination of fluid density

The fluid density shall be determined in such a way as to ensure that the uncertainty in the value obtained does not exceed $\pm 0,5\%$ (at 95 % confidence level).

When the fluid density is obtained from the absolute static pressure and static temperature, these quantities may generally be taken from single readings made at a point located at a distance $0,75R$, where R is the pipe radius, from the wall. Nevertheless, for measurements in a compressible fluid where the ratio of the maximum differential pressure to the absolute static pressure in the plane of the traverse is greater than 0,01, the procedure described in [8.2](#) and in [Clause E.3](#) shall be followed.

6.5 Inspection and maintenance of the Pitot tube

The Pitot tube does not require any special maintenance, but it shall be ensured, before and after the measurements, that the tube used complies with the criteria specified in [Clause 5](#).

The following points in particular shall be checked:

- a) the pressure sensing holes and their connecting tubes are not blocked;
- b) there is no leakage between the chambers inside the Pitot tube which receive the total pressure and the static pressure;
- c) the tube has not been strained, or its nose damaged;
- d) the tube is clean;
- e) the head of the Pitot tube is truly perpendicular to the supporting stem.

Furthermore, since the determination of the velocity is related to the differential pressure, it shall also be checked that:

- f) the connections to the pressure gauge are as short as possible;
- g) the connections are absolutely leak-tight (porous or cracked rubber tubes, etc., are not permissible);
- h) they are in general in accordance with ISO 2186;
- i) where damping of the differential pressure gauge is necessary, it is symmetrical and linear (see [Annex D](#)).

7 Positioning of Pitot tube

The axis of the Pitot tube head shall be set parallel to the pipe axis; an alignment arm shall be provided to assist in doing this.

The Pitot tube shall be rigidly fixed during the measurements.

The Pitot tube shall be positioned in the pipe in accordance with the requirements of [4.4.1](#) and [Clause 9](#) or [Clause 11](#).

The device which holds the Pitot tube in the pipe shall be such that no leak can occur into or out of the pipe.

8 Velocity computation

8.1 Verification of conditions for a measurement

Provided that the Reynolds number based on the diameter of the total pressure hole of the Pitot tube is in excess of 200, and that the local Mach number (for measurements in a compressible fluid) does not

exceed 0,25, the local velocity may be calculated. However, [Annex E](#) shall give indications on the method of carrying out velocity measurements in the case of a compressible fluid at a higher Mach number.

The first condition is equivalent to a requirement that Δp is never less than

$$\frac{2 \times 10^4}{\rho} \left(\frac{\mu}{\alpha d_i} \right)^2 \quad (2)$$

where

Δp is the differential pressure measured by the Pitot tube;

ρ is the density of the fluid;

μ is the dynamic viscosity of the fluid;

d_i is the diameter of the total pressure hole of the Pitot tube;

α is the calibration factor of the Pitot tube: to be taken as 1 for this calculation.

The second condition requires that, for measurement in a compressible fluid, the ratio of the differential pressure to the absolute value of the pressure recorded by the static pressure tapping of the Pitot tube shall never exceed a limiting value, which varies with γ (the ratio of the specific heat capacities of the gas) according to [Table 1](#).

Table 1 — Ratio of the differential pressure varying with γ

γ	1,1	1,2	1,3	1,4	1,5	1,6	1,7
$(\Delta p/p)_{\max}$	0,035	0,038	0,042	0,046	0,048	0,052	0,054

8.2 Formulae for velocity computation

The local velocity of a fluid in a steady flow without transverse velocity gradient or turbulence at Reynolds numbers, v , based on the internal diameter of the total pressure tapping, greater than 200 is given by the [Formula \(3\)](#)

$$v = \alpha(1 - \varepsilon) \sqrt{\frac{2\Delta p}{\rho}} \quad (3)$$

in which $(1 - \varepsilon)$ is a compressibility correction factor. In a liquid, $\varepsilon = 0$ so that no compressibility correction is required, but in a compressible fluid at low Mach numbers the factor $(1 - \varepsilon)$ may be determined by the relationship given in [Formula \(4\)](#):

$$1 - \varepsilon \approx \left[1 - \frac{1}{2\gamma} \frac{\Delta p}{p} + \frac{\gamma - 1}{6\gamma^2} \left(\frac{\Delta p}{p} \right)^2 \right]^{1/2} \quad (4)$$

where

γ is the ratio of specific heat capacities;

ρ is the local density of the fluid;

Δp is the differential pressure indicated by the Pitot tube;

α is the calibration factor of the Pitot tube (under the above-mentioned conditions and for Pitot tubes described in this document, it is practically equal to 1,00);

p is the local static pressure (or absolute static pressure).

The density, ρ , of the compressible fluid is determined from [Formula \(5\)](#):

$$\rho = \frac{pM}{ZR_g T} \quad (5)$$

where

p is the local static pressure;

R_g is the molar constant of gas, 8,314 3 J/mol·K;

M is the molar mass of fluid, in kilograms per mole, having a value 0,028 95 kg/mol for air;

Z is the gas law deviation factor — it is insignificantly different from unity for air at absolute pressures less than 10 times atmospheric and temperatures between 273 K and 373 K [it should be distinguished from $(1 - \varepsilon)$, the compressibility correction factor];

T is the local static temperature given by the formula.

NOTE This formula is an approximation which is adequately precise for the purposes of this document.

$$\frac{T_0}{T} = \left[1 + \frac{\gamma - 1}{\gamma} \frac{\Delta p}{p} \right] \quad (6)$$

To be the total temperature measured on the axis of the duct using an ideal total temperature probe. The effect of using any non-ideal temperature probe is discussed in [Annex E](#).

For selected values of γ and $\Delta p/p$ values of $(1 - \varepsilon)$, together with T/T_0 , are shown in [Table 2](#).

Table 2 — Examples of values

$\Delta p/p$	γ													
	1,1		1,2		1,3		1,4		1,5		1,6		1,7	
	T/T_0	$(1 - \varepsilon)$	T/T_0	$(1 - \varepsilon)$	T/T_0	$(1 - \varepsilon)$	T/T_0	$(1 - \varepsilon)$	T/T_0	$(1 - \varepsilon)$	T/T_0	$(1 - \varepsilon)$	T/T_0	$(1 - \varepsilon)$
0,01	0,999	0,998	0,998	0,998	0,998	0,998	0,997	0,998	0,997	0,998	0,996	0,998	0,996	0,999
0,02	0,998	0,996	0,997	0,996	0,995	0,996	0,994	0,997	0,993	0,997	0,993	0,997	0,992	0,997
0,03	0,997	0,993	0,995	0,994	0,993	0,994	0,992	0,995	0,990	0,995	0,989	0,995	0,988	0,996
0,04	0,996	0,991	0,994	0,992	0,991	0,993	0,989	0,993	0,987	0,994	0,985	0,994	0,984	0,994
0,05	—	—	—	—	0,989	0,991	0,986	0,991	0,984	0,992	0,982	0,992	0,980	0,993

9 Determination of the discharge velocity by graphical integration of the velocity area

The general principle of this method is specified in [4.1](#).

The measuring points shall be located along straight lines, and in order to determine m accurately, two measuring points shall be placed on each straight line as close as possible to the wall in accordance with [Annex F](#).

The number and position of the other points shall be selected in such a manner that the velocity profile can be determined satisfactorily. They will usually be distributed in the cross-section in such a way as to divide it into areas, each of which has the same flow rate in order to attach approximately the same importance to all measuring points.

Reference should be made to [4.4](#) when determining the number and location of measuring points, and to [Clause 12](#) when it is considered necessary to make some correction to local velocity measurements or to the position of measuring points.

9.1 Circular cross-section

If v is the flow velocity at a point of polar co-ordinates, r, θ , and if R is the mean radius of the measuring section, the discharge velocity, U , is

$$U = \frac{1}{\pi R^2} \int_0^{2\pi} \int_0^{R_v} (r, \theta) r \, dr \, d\theta = \int_0^1 u d\left(\frac{r}{R}\right)^2 = \int_0^{\left(\frac{r_n}{R}\right)^2} u d\left(\frac{r}{R}\right)^2 + \int_{\left(\frac{r_n}{R}\right)^2}^1 u d\left(\frac{r}{R}\right)^2 \quad (7)$$

where

u is the spatial mean velocity along the circumference of radius, r ;

r_n is the radius of the circle defined by the measuring points closest to the wall.

The method used consists in:

- a) taking u_c (arithmetic mean of the velocities at the measuring points located on one circle of radius, r_c) as the value of u ;
- b) plotting u_c against $(r_c/R)^2$ between $r = 0$ and $r = r_n$ (see [Figure 1](#));

NOTE To facilitate plotting in the vicinity of the measuring point closest to the wall, the tangent line to the curve for $r = r_n$ will be drawn with a slope equal to:

$$\left(\frac{du_c}{dx}\right)_{r=r_n} = \frac{-u_n}{2m \frac{r_n}{R} \left(1 - \frac{r_n}{R}\right)}$$

denoting $(r/R)^2$ as x .

The slope of the curve is derived from Karman's conventional law for the variation of the fluid velocities in the peripheral zone:

$$u = u_n \left(\frac{R-r}{R-r_n}\right)^{1/m}$$

- c) graphically determining the value of the area below this curve (see [Figure 1](#));
- d) adding to this value a calculated term corresponding to the peripheral zone and equal to:

$$\frac{m}{m+1} u_n \left(1 - \frac{r_n^2}{R^2}\right) \quad (8)$$

where

u_n is the value of the arithmetic mean of the velocities at the measuring points located on the circle of radius, r_n (i.e. the closest to the wall);

m is the coefficient depending on the wall roughness and on the flow conditions, the value of which can be determined in accordance with the indications given in [Annex F](#) and is generally between 4 (rough wall) and 10 (smooth wall).

NOTE This simplified expression omits the other term

$$\frac{-m}{(m+1)(2m+1)} u_n \left(1 - \frac{r_n}{R}\right)^2$$

in the result of the integration (within the peripheral zone) derived from Karman's conventional law: this latter term only represents about

$$\frac{1 - \left(\frac{r_n}{R}\right)}{4m+2}$$

times the flow in the peripheral zone.

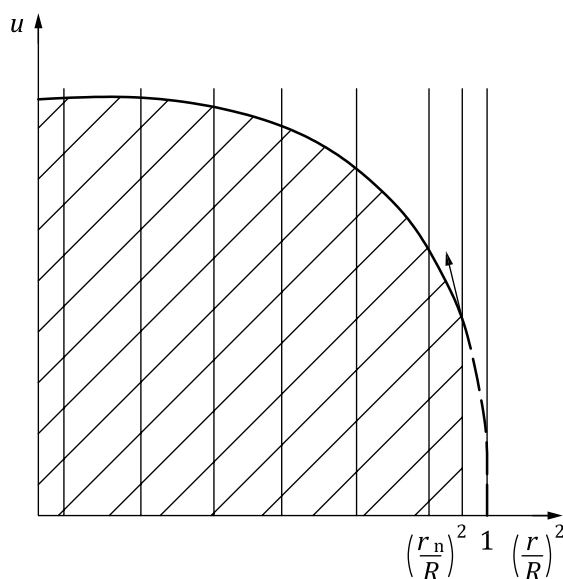

Figure 1 — Computation of the discharge velocity in a circular conduit — Graphical integration in the area explored by the Pitot tubes

9.2 Rectangular cross-sections

The computation of the discharge velocity requires a double integration across both dimensions of the conduit. Measurement shall be started either on the vertical lines or on the horizontal lines³⁾. The computation is developed here starting with horizontal line measurements.

The formula for the discharge velocity is:

$$U = \int_0^1 \int_0^1 v d\left(\frac{h}{H}\right) d\left(\frac{l}{L}\right) \quad (9)$$

where

3) Throughout this subclause, a “vertical line” will mean a line parallel to the conduit height and a “horizontal” line will mean a line parallel to the conduit width.

- L is the conduit width in the measuring cross-section (arithmetic mean of the widths measured on at least each horizontal measuring line);
- H is the conduit height in the measuring cross-section (arithmetic mean of the heights measured on at least each vertical measuring line);
- l is the distance from a particular point to the side-wall chosen as origin;
- h is the height of a particular point above the bottom.

The method used consists in:

- a) plotting the variation curve of the velocity on each horizontal line between the extreme measuring points, as a function of the relative distance l/L (see [Figure 2](#));

NOTE To facilitate plotting in the vicinity of the extreme measuring points, the tangent line to the curve at each of them will be drawn with a slope the absolute value of which is equal to

$$\frac{v_a L}{ma}$$

where

- v_a is the velocity at the considered extreme measuring point (at a distance a from the nearest wall);
- m is a coefficient depending on the wall roughness and on the flow conditions, the value of which can be determined in accordance with the indications given in [Annex F](#) and is generally between 4 (rough wall) and 10 (smooth wall).

The slope of this curve is derived from Karman's conventional law, for the variation of the fluid velocities in the peripheral zone:

$$v_x = v_a \left(\frac{x}{a} \right)^{1/m}$$

- b) determining graphically the value of the area below this curve between the extreme measuring points (see [Figure 2](#));
- c) adding to this value two terms corresponding to the peripheral zones, both being equal to

$$\left(\frac{m}{m+1} \right) \left(\frac{a}{L} \right) (v_a) \quad (10)$$

(the sum so obtained is the mean velocity, u_i , on the horizontal measuring line concerned);

- d) plotting the variation curve of u_i between the extreme horizontal measuring lines as a function of the relative height, h/H , of the corresponding horizontal line (see [Figure 2](#))⁴⁾;
- e) graphically determining the value of the area below this curve between the extreme horizontal measuring lines;
- f) adding to this last value two terms, corresponding to the peripheral zones, in order to obtain the discharge velocity. Both terms are equal to:

$$\left(\frac{m}{m+1} \right) \left(\frac{a'}{H} \right) (u_{a'}) \quad (11)$$

4) To facilitate plotting in the vicinity of the peripheral zones, the same procedure shall be followed as in determining the mean velocity along each horizontal line [see [9.2 a](#)].

where u_a' is the mean velocity on the horizontal measuring line closest to the wall (at a distance a' from the wall).

10 Determination of the discharge velocity by numerical integration of the velocity area

The general principle of this method is specified in [4.1](#).

The formulae proposed below are derived from interpolations between successive pairs of measuring points along third-degree curves in $(r/R)^2$ for a circular cross-section conduit, or in l/L or h/H for a rectangular cross-section conduit. The separate individual arcs combine to form a continuous curve with a continuous derivative.

In the peripheral zone, the same law as indicated in [Clause 9](#) is applied.

For the number and position of measuring points, reference shall be made to the indications of [Clause 9](#) and [4.4](#). Reference shall be made to [Clause 12](#) when it is considered necessary to apply certain corrections to local velocity measurements or to the position of measuring points.

10.1 Circular cross-sections

If v_0 is the velocity at the conduit centre, and u_1, u_2, \dots, u_n are the mean velocities [calculated as indicated in [9.1 a](#)] along the circumferences with increasing relative radii $r^*_1, r^*_2, \dots, r^*_n$ (with $r^*_i = r_i/R$, where R is the radius of the cross-section), the discharge velocity in the cross-section, U , is given by [Formula \(12\)](#):

$$\begin{aligned}
 U = & v_0 \left(-\frac{1}{12}r_2^{*2} + \frac{5}{12}r_1^{*2} + \frac{1}{12}\frac{r_1^{*3}}{r_2^*} \right) + u_1 \left(\frac{1}{6}r_1^{*2} + \frac{2}{3}r_2^{*2} - \frac{1}{12}r_3^{*2} \right) - u_2 \left(\frac{r_1^{*3}}{12r_2^*} \right) \\
 & + \sum_{i=2}^{i=n-2} u_i \left[-\frac{1}{12}r_{(i+2)}^{*2} + \frac{2}{3}r_{(i+1)}^{*2} - \frac{2}{3}r_{(i-1)}^{*2} + \frac{1}{12}r_{(i-2)}^{*2} \right] + u_{(n-1)} \left[\frac{1}{2}r_n^{*2} + \frac{1}{12}r_{(n-1)}^{*2} - \frac{2}{3}r_{(n-2)}^{*2} + \frac{1}{12}r_{(n-3)}^{*2} \right] \\
 & + u_n \left\{ \frac{m}{m+1} (1-r_n^{*2}) + \frac{[r_n^{*2} - r_{(n-1)}^{*2}]^2}{12m(1-r_n^{*2})} + \frac{7}{12}r_n^{*2} - \frac{2}{3}r_{(n-1)}^{*2} + \frac{1}{12}r_{(n-2)}^{*2} \right\}
 \end{aligned} \tag{12}$$

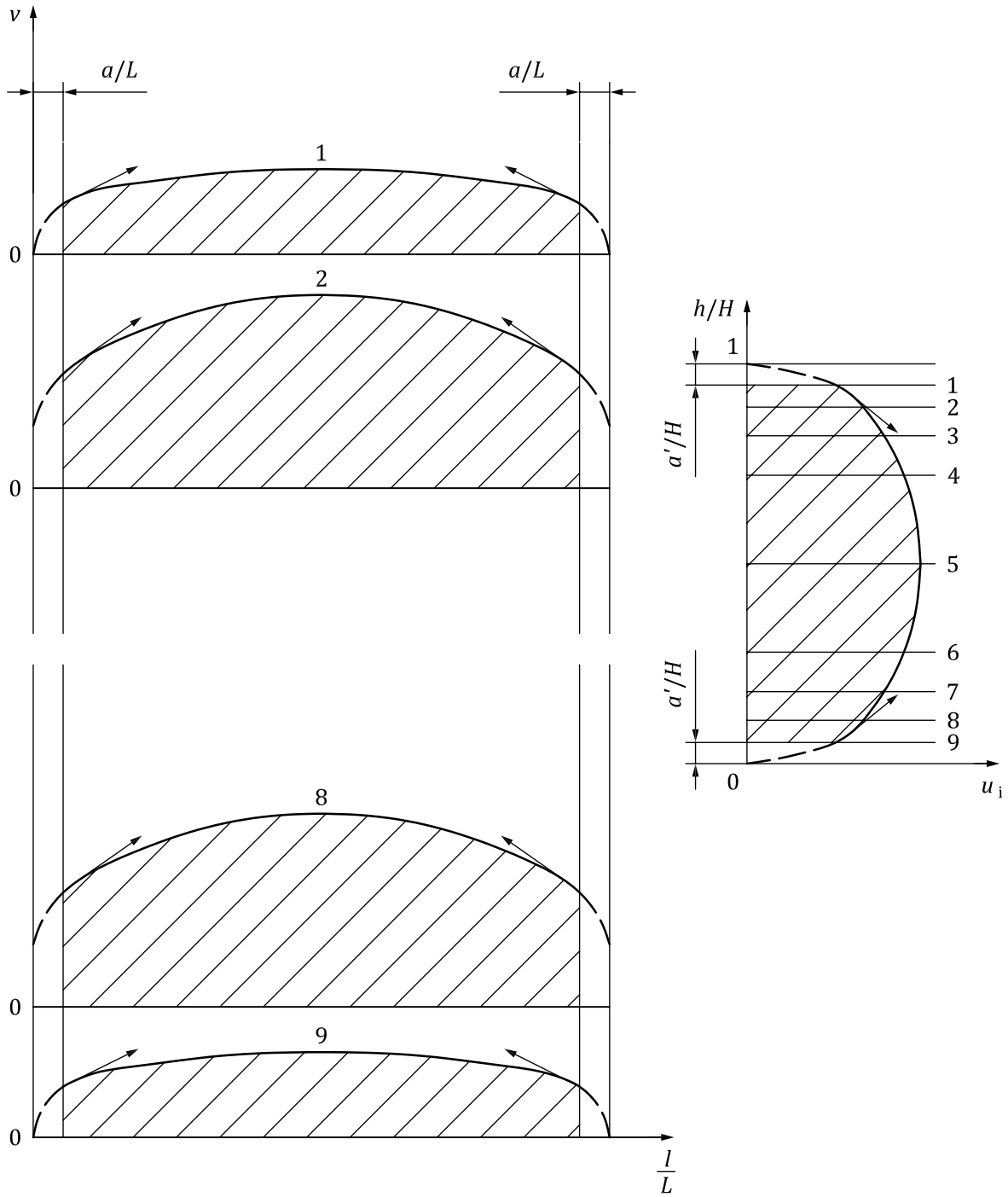

Figure 2 — Computation of the discharge velocity in a rectangular conduit — Graphical integration in the area explored by Pitot tubes

NOTE When $n = 4$, the summation term is evaluated only for $i = 2$.

When $n = 3$, the summation term disappears and [Formula \(1\)](#) simplifies to:

$$U = v_0 \left(-\frac{1}{12} r_2^{*2} + \frac{5}{12} r_1^{*2} + \frac{1}{12} \frac{r_1^{*3}}{r_2^*} \right) + u_1 \left(\frac{1}{6} r_1^{*2} + \frac{2}{3} r_2^{*2} - \frac{1}{12} r_3^{*2} \right) + u_2 \left(-\frac{r_1^{*3}}{12 r_2^*} - \frac{2}{3} r_1^{*2} + \frac{1}{12} r_2^{*2} - \frac{1}{2} r_3^{*2} \right) + u_3 \left[\frac{m}{m+1} (1 - r_3^{*2}) + \frac{[r_3^{*2} - r_2^{*2}]^2}{12m(1 - r_3^{*2})} + \frac{7}{12} r_3^{*2} - \frac{2}{3} r_2^{*2} + \frac{1}{12} r_1^{*2} \right]$$

10.2 Rectangular cross-sections

In the following formula, U represents:

- either the mean velocity along a measuring line, in which case v_1, v_2, \dots, v_n are the velocities measured at points located at distances l_1, l_2, \dots, l_n from the reference wall; L is the distance between the two walls on the considered line:

$$y_1^* = \frac{l_1}{L}, y_2^* = \frac{l_2 - l_1}{L}, \dots, y_n^* = \frac{l_n - l_{(n-1)}}{L}, y_{(n+1)}^* = \frac{L - l_n}{L} \quad (13)$$

- or the discharge velocity in the measuring cross-section, in which case v_1, v_2, \dots, v_n represent the mean velocities u_1, u_2, \dots, u_n along the measuring lines located at distances h_1, h_2, \dots, h_n from the reference wall; H is the height of the measuring cross-section:

$$y_1^* = \frac{h_1}{H}, y_2^* = \frac{h_2 - h_1}{H}, \dots, y_n^* = \frac{h_n - h_{(n-1)}}{H}, y_{(n+1)}^* = \frac{H - h_n}{H} \quad (14)$$

$$U = v_1 \left(\frac{m}{m+1} y_1^* + \frac{1}{12m} \frac{y_2^{*2}}{y_1^*} + \frac{7}{12} y_2^* - \frac{1}{12} y_3^* \right) + v_2 \left(\frac{1}{2} y_2^* + \frac{7}{12} y_3^* - \frac{1}{12} y_4^* \right) + \sum_{i=3}^{i=n-2} v_i \left\{ \frac{7}{12} [y_{(i+1)}^* + y_i^*] - \frac{1}{12} [y_{(i+2)}^* + y_{(i-1)}^*] \right\} + v_{(n-1)} \left[\frac{1}{2} y_n^* + \frac{7}{12} y_{(n-1)}^* - \frac{1}{12} y_{(n-2)}^* \right] + v_n \left[\frac{m}{m+1} y_{(n+1)}^* + \frac{1}{12m} \frac{y_2^{*2}}{y_{(n+1)}^*} + \frac{7}{12} y_n^* - \frac{1}{12} y_{(n-1)}^* \right]$$

NOTE When $n = 5$, the summation term is evaluated only for $i = 3$.

11 Determination of the discharge velocity by arithmetic methods

The general principle of these methods is specified in [4.1](#).

For each method the measuring cross-section is divided into a small number of section elements. The measuring locations are predetermined for each section element from:

- an assumption of the mathematical form of the velocity distribution law in the section element concerned;
- a choice of the weighting coefficients.

The various curves corresponding to each section element do not need to constitute a continuous curve with a continuous derivative.

In the peripheral zone, a logarithmic law is assumed for velocity distribution with respect to the distance from the wall. In the arithmetical methods described hereafter, the weighting coefficients have been chosen to be equal in the case of circular cross-sections and the section elements have areas proportional to the number of measuring points in the element concerned; reference shall be made to [Clause 12](#) when it is considered necessary to make certain corrections to local velocity measurements or to the positions of measuring points.

11.1 “Log-linear” method

By hypothesis, the mathematical form of the velocity distribution law for each element is given by [Formula \(15\)](#):

$$u = A \log y + By + c \tag{15}$$

where

- y is the distance to the wall;
- A, B and C are any three constants (except for the external ring element where B is zero).

11.1.1 Circular cross-sections

The location of the measuring points corresponds to the values of the relative radius, r/R_i , or of the relative distance to the wall, y/D_i , shown in [Table 3](#).

Table 3 — Number of measuring points versus relative radius and relative distance

Number of measuring points per radius	r/R_i	y/D_i
3	0,358 6 ± 0,010 0	0,320 7 ± 0,005 0
	0,730 2 ± 0,010 0	0,134 9 ± 0,005 0
	0,935 8 ± 0,003 2	0,032 1 ± 0,001 6
5	0,277 6 ± 0,010 0	0,361 2 ± 0,005 0
	0,565 8 ± 0,010 0	0,217 1 ± 0,005 0
	0,695 0 ± 0,010 0	0,152 5 ± 0,005 0
	0,847 0 ± 0,007 6	0,076 5 ± 0,003 8
	0,962 2 ± 0,001 8	0,018 9 ± 0,000 9

The mean velocity on each radius is taken as equal to the arithmetic mean of the velocities determined at the measuring points located on the radius concerned, and the discharge velocity is equal to the arithmetic mean of the mean velocities on each radius. The discharge velocity is therefore given by the arithmetic mean of local velocities.

11.1.2 Rectangular cross-sections

Different layouts may be developed to apply the log-linear method in a rectangular cross-section, using a variety of numbers of measuring points. This document is limited to the method using 26 points, for which the location is given in [Figure 3](#).

In addition to the location of the measuring points given by l/L and h/H , [Table 4](#) gives the weighting coefficients for each measured velocity.

The discharge velocity, U , is equal to the weighted mean of the measured local velocities, following [Formula \(16\)](#):

$$U = \frac{\sum k_i v_i}{\sum k_i} \quad (16)$$

For the method using 26 points $\sum k_i = 96$.

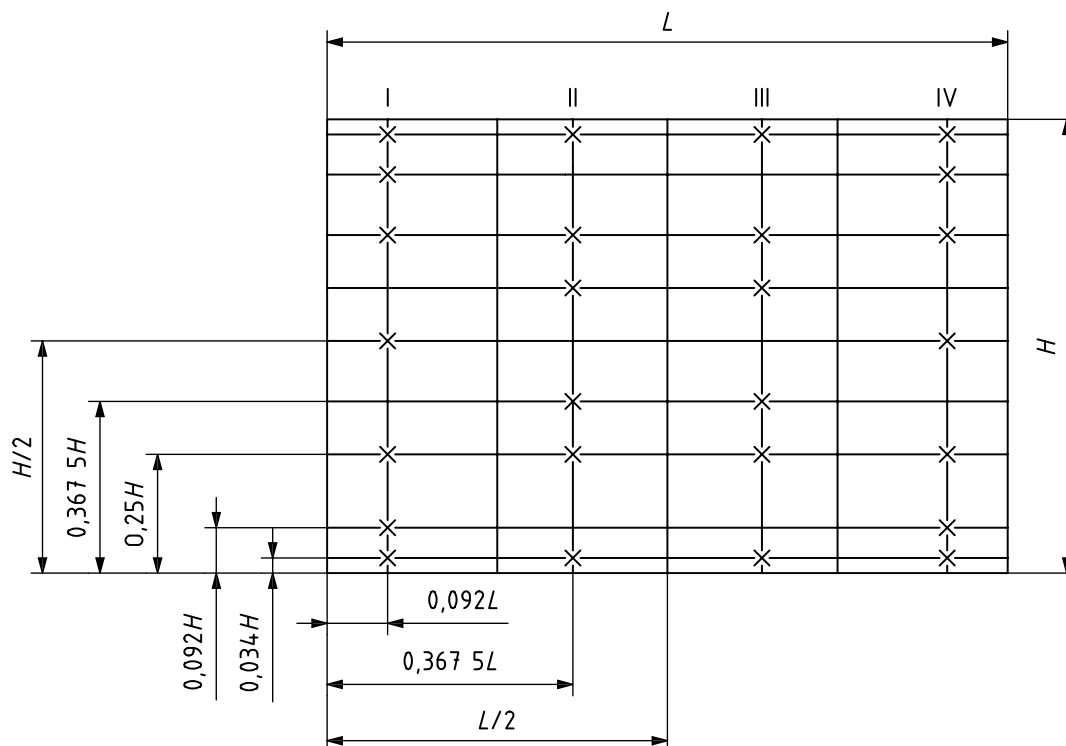

Figure 3 — Location of measuring points in a rectangular cross-section conduit for the log-linear method using 26 points

Table 4 — Log-linear method in a rectangular cross-section — Location of measuring points and weighting coefficients

h/H	l/L			
	I	II	III	IV
	0,092	0,367 5	0,632 5	0,908
0,034	2	3	3	2
0,092	2	—	—	2
0,250	5	3	3	5
0,367 5	—	6	6	—
0,500	6	—	—	6
0,632 5	—	6	6	—
0,750	5	3	3	5
0,908	2	—	—	2
0,966	2	3	3	2

11.2 Log-Chebyshev method

By hypothesis the mathematical form of the velocity distribution law as a function of the distance from the wall is logarithmic in the outermost elements of the section and polynomial in the other elements.

11.2.1 Circular cross-sections

The position of the measuring points corresponds to the values of the relative radius, r/R_i , or of the relative distance to the wall, y/D_i , shown in [Table 5](#).

As the weighting coefficients have been chosen to be equal, the discharge velocity is equal to the arithmetic mean of the measured local velocities.

Table 5 — Correspondence between r/R values and measuring points

Number of measuring points per radius	r/R_i	y/D_i
3	$0,375\ 4 \pm 0,010\ 0$	$0,312\ 3 \pm 0,005\ 0$
	$0,725\ 2 \pm 0,010\ 0$	$0,137\ 4 \pm 0,005\ 0$
	$0,935\ 8 \pm 0,003\ 2$	$0,032\ 1 \pm 0,001\ 6$
4	$0,331\ 4 \pm 0,010\ 0$	$0,334\ 3 \pm 0,005\ 0$
	$0,612\ 4 \pm 0,010\ 0$	$0,193\ 8 \pm 0,005\ 0$
	$0,800\ 0 \pm 0,010\ 0$	$0,100\ 0 \pm 0,005\ 0$
	$0,952\ 4 \pm 0,002\ 4$	$0,023\ 8 \pm 0,001\ 2$
5	$0,286\ 6 \pm 0,010\ 0$	$0,356\ 7 \pm 0,005\ 0$
	$0,570\ 0 \pm 0,010\ 0$	$0,215\ 0 \pm 0,005\ 0$
	$0,689\ 2 \pm 0,010\ 0$	$0,155\ 4 \pm 0,005\ 0$
	$0,847\ 2 \pm 0,007\ 6$	$0,076\ 4 \pm 0,003\ 8$
	$0,962\ 2 \pm 0,001\ 8$	$0,018\ 9 \pm 0,000\ 9$

11.2.2 Rectangular cross-sections

A number, e , of traverse straight lines, at least equal to five, are selected parallel to the smaller side of the rectangle; on each of them a number, f , of measuring points, at least equal to five, are located. (See [Figure 4](#).)

NOTE For the example chosen, $f = 5$ and $e = 6$.

The positions of e or f measuring points (abscissa X_i and ordinate Y_j in relation to the centre of the section) are defined from [Table 6](#).

As the weighting coefficients have been chosen to be equal, the discharge velocity is equal to the arithmetic mean of the measured local velocities at the various measuring points.

Table 6 — Positions of measuring points

e or f	Values of X_i/L or Y_j/H			
5	0	$\pm 0,212$	$\pm 0,426$	
6	$\pm 0,063$	$\pm 0,265$	$\pm 0,439$	
7	0	$\pm 0,134$	$\pm 0,297$	$\pm 0,447$

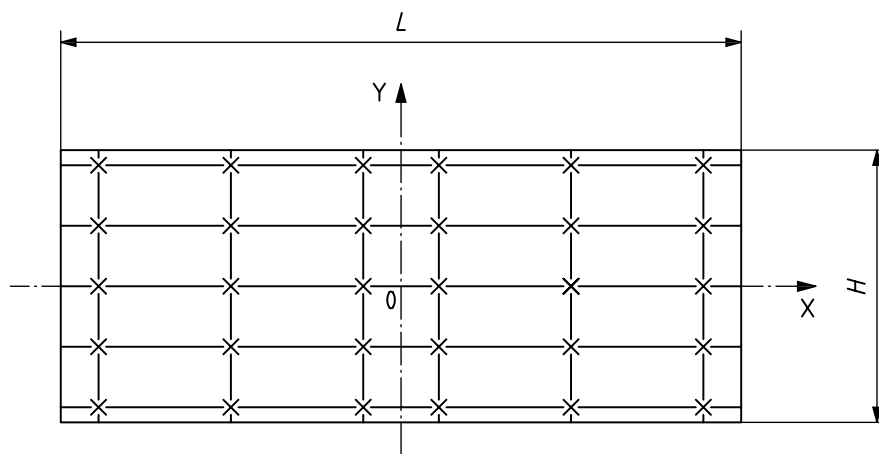

Figure 4 — Position of the measuring points in a rectangular conduit in the case of the log-Chebyshev method

12 Corrections of local velocity measurements

The measurement of local velocity is affected by errors which are due in particular to the blockage effect, to the velocity gradient, to turbulence and to the head loss which would require corrections whose amount is unfortunately not always exactly known. These corrections are in fact only applied when very accurate measurement is required or if errors are very large.

The following subclauses give indications of the values which can be expected from these corrections. The theoretical bases of the estimation are given in [Annexes B](#) and [C](#).

12.1 Correction for stem blockage

When a Pitot static tube is used in an infinite stream, the calibration factor takes account of the stem influence on the pressure readings at static pressure tapings.

When the tube is used in a conduit, the velocity increase when the flow passes between the stem and the walls causes a decrease in the recorded static pressure without affecting the total pressure. The differential pressure Δp shall therefore be reduced to take account of the stem blockage effect.

12.1.1 Case where the correction can be neglected

When the ratio d/D is less than or equal to 0,02 as specified in [6.3.4](#), and when the Pitot tube is consecutively introduced into two diametrically opposite insertion holes in such a way that traverse only occurs across one radius, the correction for blockage effect can be neglected. In the other cases, the correction to be made shall be estimated before it is determined whether or not it can be neglected in view of the required accuracy.

12.1.2 Estimation of the correction of local velocity measurement

The correction for each individual measurement, Δp , is given by:

$$\delta(\Delta p) = -0,7k_b(S/A)\Delta p_{\max} \quad (17)$$

where

Δp is the recorded value of the differential pressure;

Δp_{\max} is the corresponding value on the conduit axis;

S is the frontal projected area of that portion of the stem inside the conduit;

A is the cross-sectional area of the conduit;

k_b is the blockage coefficient of a cylindrical stem (see [Figure 5](#)).

The value of 0,7 is an average (0,65 to 0,75) of the ratio of the mean value to the maximum value of the squared velocity in the conduit cross-section.

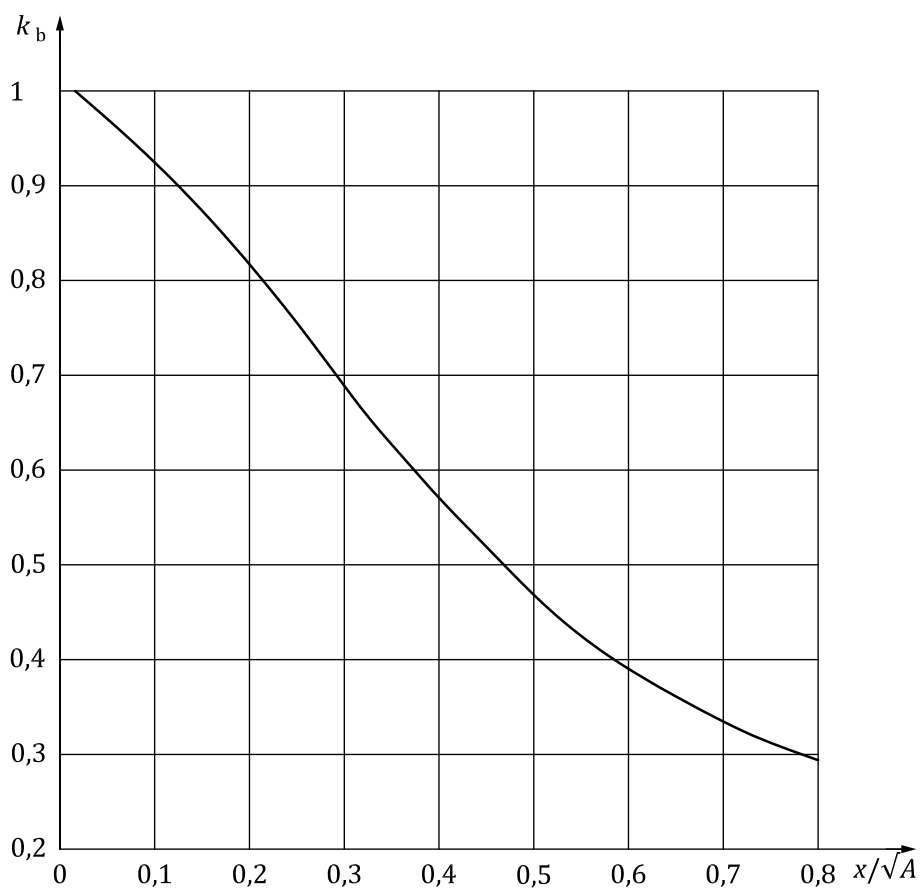

Key

A cross-sectional area of conduit

k_b blockage coefficient of a cylindrical stem

x distance from plane of static holes to axis of Pitot-stem

Figure 5 — Variation of blockage constant with distance ahead of cylindrical stem in a closed conduit

12.1.3 Estimation of the overall correction of the flow-rate value (application to arithmetic methods)

The relative error caused in ignoring the correction of local velocity for the point situated at a distance, y , from the wall can be calculated as follows for a velocity profile of the shape, $v/v_{\max}=(y/R)^{1/m}$:

$$\frac{\delta(v/v_{\max})}{(v/v_{\max})} = -\frac{(m+2)(m+1)}{2m^2}(R/y)^{2/m} k_b (S/A) \quad (18)$$

If the result is applied to each point, the position of which is predetermined by arithmetic methods ([Clause 11](#)), the overall corrections for flow rate are practically identical for all arithmetic methods. Their values are given in [Figure 6](#).

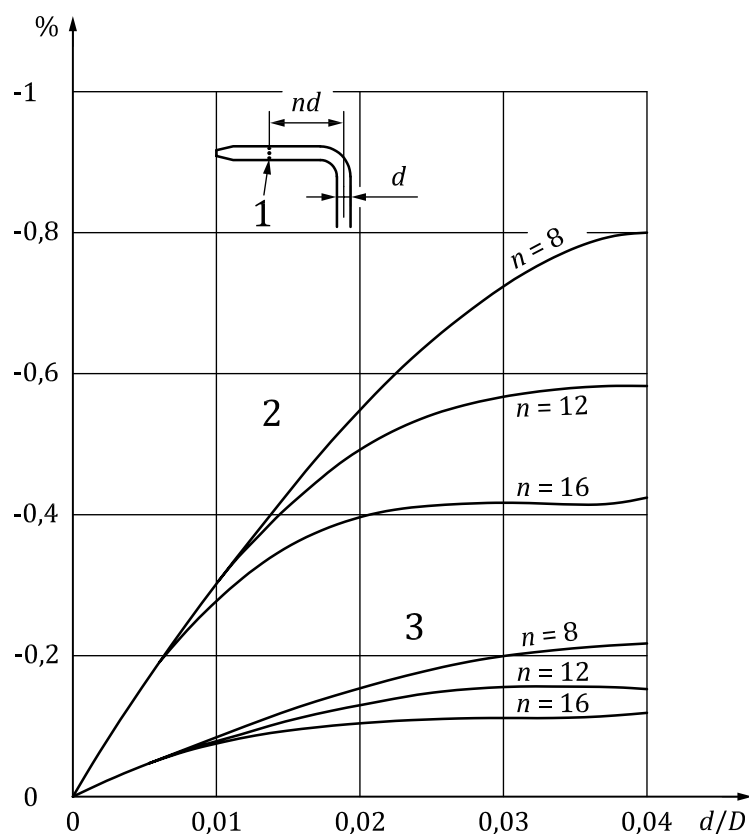

Key

- 1 static holes
- 2 one insertion hole/diameter
- 3 two insertion holes/diameter
- d head diameter
- d/D ratio of head diameter to pipe diameter
- n number of measurements
- nd distance of the total pressure tapping to the plane of static pressure tappings

Figure 6 — Overall correction to be added to volume flow rate to allow for Pitot-stem blockage

12.2 Correction for transverse velocity gradient

The stagnation pressure recorded by a Pitot tube in a fluid flow with a transverse velocity gradient is always slightly overestimated. Interaction between the nose of the Pitot tube and the fluid flow causes a small displacement of the approaching streamlines, so that the tube brings to rest a streamline

originating in a higher velocity region ahead of the plane of measurement. [Annex B](#) gives a few justifications of how the corrections indicated below are evaluated.

This influence can be taken into account in two ways, either by integrating the velocity area on the basis of the corrected position of the measuring points (see [12.2.1](#)) or, for arithmetic methods only, by keeping the predetermined position and making an overall correction for flow rate (see [12.2.2](#)).

12.2.1 Correction for measuring point position

12.2.1.1 Case of graphical or numerical integration

Measurements of differential pressure, Δp , recorded at real distances, y , from the wall are considered for calculation as being carried out at distances, $y + \Delta y$, where Δy is the fictitious displacement of the measuring point which can be calculated using the following formula:

$$\frac{\Delta y}{d} = k_g - 0,195 k_g \left(\frac{d}{y} \right) \left[1 - \frac{1}{\sqrt{1 + \left(\frac{10,24}{k_g} \right) \left(\frac{y}{d} \right)^2}} \right] \quad (19)$$

If the value k_g has not been determined once for all for any particular nose shape, k_g can be taken as $0,10 \pm 0,02$ for all Pitot tubes meeting the requirements of [5.2](#). [Table 7](#) can be used for displacement evaluation of Pitot tubes with $k_g = 0,10$ and for a certain range of distance from the wall.

Table 7 — Exemplary values for the displacement evaluation of Pitot tubes

y/d	0,50	0,67	0,75	1,0	1,5	2	3	4	∞
$\Delta y/d$	0,069	0,075	0,077	0,082	0,088	0,091	0,094	0,095	0,100

Do not forget the correction for displacement when m is determined in accordance with the requirements of [Annex F](#).

12.2.1.2 Case of arithmetical methods

When measuring positions are calculated in accordance with [Tables 3, 4, 5](#) and [6](#), the corresponding y distances shall be reduced by Δy as calculated above to obtain the real position y_1 to be used for measurements.

12.2.2 Overall correction of flow rate

[Figure 7](#) gives an indication of the corrections to be made to the flow-rate value in a circular conduit when a Pitot tube with $k_g = 0,10$ is used for the measurements. For measurements with slightly different k values, it is permitted to correct the values of the figure with a ratio of $k_g/0,10$.

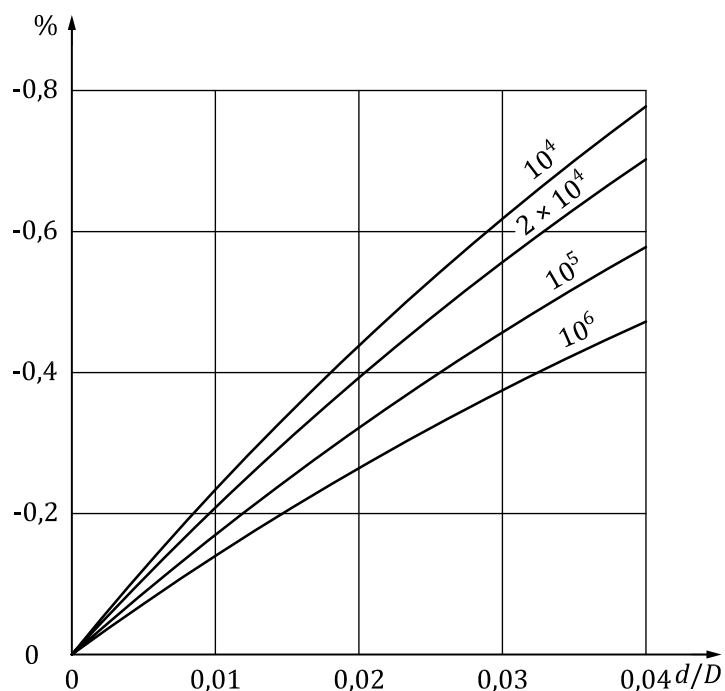

a) 3 points/radius, log-linear, log-Chebyshev

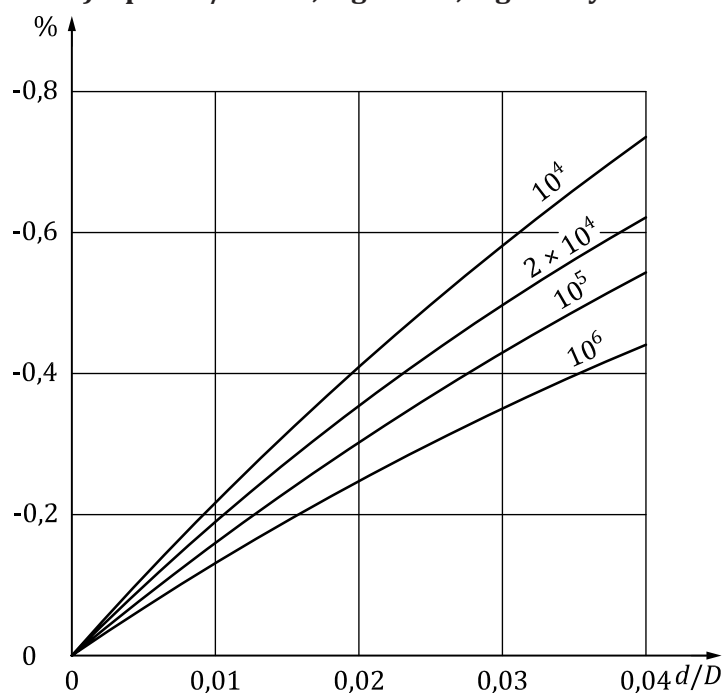

b) 5 points/radius, log-linear, log-Chebyshev

Figure 7 — Overall correction to be added to volume flow rate to allow for Pitot-displacement

12.3 Correction for turbulence

It may be assumed that, for approximately 10 % turbulence, the correction of the local velocity value is about -0,5 % to -2 % according to the nose shape of the Pitot tube used and the Reynolds number of the fluid flow (see [Annex C](#)).

12.4 Correction for head loss

Since the static pressure tapping is located at a distance downstream of the local pressure tapping, the pressure measurement is affected by an error which is equal to the friction head loss in the conduit over this distance. The measured differential pressure is therefore slightly overestimated.

This correction is generally negligible, but if it is considered necessary to take it into account, the differential pressure at each measuring point shall be reduced by the head loss, ξ :

$$\xi = \left(\frac{\lambda nd}{D} \right) \rho \frac{U^2}{2} \quad (20)$$

where

λ is the universal coefficient for head loss;

nd is the distance of the total pressure tapping to the plane of static pressure tappings.

13 Errors

This clause defines a number of fundamental statistical terms which are used in this document and describes the method employed to assess the accuracy of the volume flow-rate measurement from a list of error sources involved in local velocity measurement and flow-rate calculation.

An example of calculation of the overall uncertainty is given in [Annex G](#) with the sole purpose of illustrating the described method of calculation, but it does not give typical values of the various errors. Each particular case should therefore be studied carefully.

13.1 Definition of the error

The error in the estimate of a quantity is the difference between that estimate and the true value of the quantity.

No measurement of a physical quantity is free from uncertainties arising either from systematic errors or from the random dispersion of measurement results. Systematic errors cannot be reduced by repeating measurements since they arise from the characteristics of the measuring apparatus, the installation, and the flow characteristics. However, a reduction in the random error may be achieved by repetition of measurements, since the random error of the mean of n independent measurements is \sqrt{n} times smaller than the random error of an individual measurement.

13.2 Errors in the estimation of the local velocity

13.2.1 Random errors

13.2.1.1 Error in the measurement of differential pressure

The measurement of differential pressure is necessarily affected by a random error $\delta_{\Delta p}$ which is due at the same time to the pressure gauge, to the connecting pipes between the Pitot tube and the pressure gauge and to the operator. This error does not include, however, some disturbances, such as fluctuations, which are considered separately in the following subclauses.

13.2.1.2 Error due to slow velocity fluctuations

A random error, δ_p , is incurred if the measuring period is not long enough for a correct integration of slow fluctuations of the flow velocity to be made. This error decreases when the number and duration of the measurements at a given point are increased.

13.2.1.3 Error in density

An error, δ_ρ , is incurred in the measurement of density because of inaccuracies in the temperature and pressure measurements and of the degree of cleanliness of the fluid. This error varies in importance according to the nature of the fluid and conditions.

13.2.1.4 Error in the calculation of the compressibility correction

A random error, δ_ε , is incurred in the calculation of the correction factor for compressibility $(1 - \varepsilon)$ according to the indications of [8.2](#) and [Annex E](#).

13.2.2 Systematic errors

It is assumed in the following that the corrections mentioned in [Clause 12](#) for blockage, velocity gradient, turbulence and head loss have not been applied. If they have been, a systematic error will nevertheless be made because of the noticeable uncertainty of these corrections, but this systematic error can be either positive or negative and its absolute value is obviously far less than in the first case.

13.2.2.1 Error in the Pitot tube calibration

Any error in the calibration factor of a Pitot tube systematically affects the measured velocity and introduces an error, e_c .

13.2.2.2 Error due to turbulence

The error increases with the increasing degree of turbulence of the measured fluid flow and is always positive, i.e. the measured velocity value is always greater than the actual flow velocity. Indications on the estimation of this error shall be given in [12.3](#) and [Annex C](#).

The resulting error, e_v , in the measured velocity is the same for all measurements at one and the same point and at the same velocity although errors vary with flow rate on the one hand and the measuring position on the other.

13.2.2.3 Error due to the transverse velocity gradient

The error, e_g , depends on the diameter of the Pitot tube. It is always positive. Indications on the estimation of this error shall be given in [12.2](#) and [Annex B](#).

13.2.2.4 Error due to conduit blockage

This error, e_b , increases with increasing blockage of the conduit by Pitot tubes and their supports. It is always positive. Indications on the estimation of this error are given in [12.1](#).

13.2.2.5 Error due to the inclination of the Pitot tube with respect to the flow direction

This error, e_φ , increases with the inclination angle and depends on the Pitot tube used. It is always positive when inclination remains within the limits given in [6.1.3](#). Indications on the estimation of this error shall be given in [Annex A](#).

13.2.2.6 Error due to the head loss between total and static pressure tapings

This error, e_ξ , increases with increasing spacing of pressure tapings and with the conduit roughness. It is always positive. Indications on the evaluation of this error are given in [12.4](#).

13.3 Errors in the estimation of flow rate

13.3.1 Random errors

13.3.1.1 Error due to local velocity measurements

The errors in the local velocity measurements are not truly random, as they in part depend on the position of the measurement across the duct. However, the error on each measurement is different, and the major contributions to each error are random in nature, so that the overall error, δ_{vt} , contributed to the estimation of flow rate may be regarded as random.

13.3.1.2 Error due to graph in graphical integration technique

When the graphical integration technique is used, an error, δ_i , is introduced in drawing the velocity profile and evaluating the area under the central portion of the graph; this is random in nature, and the magnitude depends both on the operator and on the shape of the velocity distribution.

13.3.1.3 Error due to evaluation of power law index, m

If the power law index, m , is calculated by the graphical method given in [Annex F](#) then the error, δ_m , from this source is random in nature.

13.3.1.4 Error due to positioning Pitot tubes

If the errors associated with the position of the Pitot tubes are independent of each other (i.e. no large common systematic error is present, see [4.4.1](#)) then the overall effect is to introduce a random error, δ_i , into the flow-rate estimation. However, provided the conditions of [4.4.1](#) are met, this error is negligible.

13.3.2 Systematic errors

13.3.2.1 Error due to measurement of duct dimensions

Although the area, A , of the plane of flow-rate measurement is evaluated from the mean of several measurements of the duct dimensions (see [4.2](#)), a systematic error, e_A , still remains in the calculated flow rate.

13.3.2.2 Error due to numerical or arithmetic integration techniques

The techniques given in [Clauses 10](#) and [11](#) either approximate the velocity distribution or assume a velocity distribution. For a given velocity distribution, there is therefore a systematic error, e_i , introduced in the calculated flow rate.

13.3.2.3 Error due to number of measuring points

If the velocity distribution curve is not perfectly smooth, the number of measuring points may not be sufficient to define it adequately, and systematic error, e_p , results.

13.4 Definition of the standard deviation⁵⁾

13.4.1 If a variable, X , is measured several times, each measurement being independent of the others, then the standard deviation, σ_X , of the distribution of n measurements, X_i , is:

$$\sigma_X = \left[\frac{\sum_{i=1}^{i=n} (\bar{X} - X_i)^2}{n-1} \right]^{1/2} \quad (21)$$

where

\bar{X} is the arithmetic mean of the n measurements of the variable X ;

X_i is the value obtained by the i^{th} measurement of the variable X ;

n is the total number of measurements of X .

For brevity, σ_X is normally referred to as the standard deviation of X .

13.4.2 If repeated measurements of a variable X are not available or are so few that direct computation of the standard deviation on a statistical basis is likely to be unreliable and if the maximum range of the measurements may be estimated, the standard deviation may be taken as 1/4 of this maximum range (i.e. as 1/2 of the estimated uncertainty above or below the adopted value of X).

13.4.3 If the various independent variables, the knowledge of which allows computation of the flow rate, are X_1, X_2, \dots, X_k , then the flow rate q_V may be expected as a certain function of these variables:

$$q_V = f(X_1, X_2, \dots, X_k) \quad (22)$$

If the standard deviations of the variables X_1, X_2, \dots, X_k , are $\sigma_1, \sigma_2, \dots, \sigma_k$, then the standard deviation σ_{q_V} of the flow rate is defined as:

$$\sigma_{q_V} = \left[\left(\frac{\partial q_V}{\partial X_1} \sigma_1 \right)^2 + \left(\frac{\partial q_V}{\partial X_2} \sigma_2 \right)^2 + \dots + \left(\frac{\partial q_V}{\partial X_k} \sigma_k \right)^2 \right]^{1/2} \quad (23)$$

where $\frac{\partial q_V}{\partial X_1}, \frac{\partial q_V}{\partial X_2}, \dots, \frac{\partial q_V}{\partial X_k}$, are partial derivatives.

13.5 Definition of the tolerance

13.5.1 For the purposes of this document, the tolerance in a measurement of a variable is defined as twice the standard deviation of the variable. The tolerance shall be calculated and quoted under this appellation whenever a measurement is claimed to be in conformity with this document.

13.5.2 When partial errors, the combination of which gives the tolerance, are independent of one another, are small and numerous, and have a gaussian distribution, there is a probability of 0,95 that the true error is less than the tolerance.

5) The standard deviation as defined here is what is more accurately referred to as the “standard deviation estimation” by statisticians.

13.5.3 Having estimated the standard deviation, σ_{q_V} , of the flow-rate measurement, q_V , the tolerance, δ_{q_V} , is given by:

$$\delta_{q_V} = \pm 2\sigma_{q_V} \quad (24)$$

The relative tolerance δ'_{q_V} is defined by;

$$\delta'_{q_V} = \frac{\delta_{q_V}}{q_V} = \pm 2 \frac{\sigma_{q_V}}{q_V} \quad (25)$$

The result of a flow measurement shall always be given in one of the following forms:

- a) flow rate = $q_V \pm \delta_{q_V}$ (at the 95 % confidence level);
- b) flow rate = $q_V (1 \pm \delta'_{q_V})$ (at the 95 % confidence level);
- c) flow rate = q_V within $\pm 100 \delta'_{q_V} \%$ (at the 95 % confidence level).

13.6 Calculation of standard deviation

13.6.1 Standard deviation on local velocity measurement

The standard deviation, σ_v , associated with a measurement of local velocity, v , is obtained by combining the standard deviations of errors arising from the sources described in 13.2. Although “systematic” errors have been distinguished from “random” errors, the probability distribution of the possible values of each systematic component is essentially gaussian. The combination of the random and systematic errors may therefore be treated as though all were truly random, and the standard deviation for the systematic components can be obtained by calculating a value for their standard deviations in the manner described in 13.4.2. Thus the standard deviation of a particular systematic component is $\pm v_{\max}/2$, where v is uncertainty, on that component.

The coefficient of variation of the local velocity measurement is then the square root of the sum of the squares of the coefficients of variation arising from the sources listed in 13.2. Thus the result of the local velocity measurement is:

$$v \left\{ 1 \pm 2 \left[\frac{1}{4} \left(\frac{\sigma_{\Delta p}}{\Delta p} \right)^2 + \left(\frac{\sigma_f}{v} \right)^2 + \frac{1}{4} \left(\frac{\sigma_\rho}{\rho} \right)^2 + \left(\frac{\sigma_\varepsilon}{v} \right)^2 + \left(\frac{\sigma_c}{v} \right)^2 + \left(\frac{\sigma_t}{v} \right)^2 + \left(\frac{\sigma_g}{v} \right)^2 + \left(\frac{\sigma_\varphi}{v} \right)^2 + \left(\frac{\sigma_b}{v} \right)^2 + \left(\frac{\sigma_\xi}{v} \right)^2 \right]^{1/2} \right\} = v \left(1 \pm 2 \frac{\sigma_v}{v} \right) \quad (26)$$

at a 95 % confidence level, where

$\sigma_{\Delta p}$ is the standard deviation arising from the error on differential pressure;

σ_ρ is the standard deviation arising from the error in density;

σ_f is the standard deviation arising from slow velocity fluctuations;

σ_ε is the standard deviation arising from compressibility;

σ_c is the standard deviation arising from the Pitot tube calibration;

σ_t is the standard deviation arising from high-frequency velocity fluctuations and turbulence;

σ_g is the standard deviation arising from the velocity gradient;

- σ_ϕ is the standard deviation arising from the inclination of the Pitot tube to the flow direction;
- σ_b is the standard deviation arising from the uncertainty in the correction for blockage;
- σ_ξ is the standard deviation arising from head loss.

13.6.2 Standard deviation on flow-rate measurement

Once again the possible values of the systematic errors which are listed in 13.3.2 have a probability distribution which is essentially gaussian, so that all errors may be treated as random for the purpose of estimating the standard deviation on the flow rate; the standard deviations on the systematic components are obtained in the same way as in 13.6.1.

The coefficient of variation of the flow-rate measurement is then the square root of the sum of the squares of the coefficients of variation arising from the sources in 13.3. Thus the result of the flow rate measurement is:

$$q_V \left\{ 1 \pm 2 \left[\left(\frac{\sigma_v}{v} \right)^2 + \left(\frac{\sigma_i}{q_V} \right)^2 + \left(\frac{\sigma_m}{q_V} \right)^2 + \left(\frac{\sigma_l}{q_V} \right)^2 + \left(\frac{\sigma_c}{v} \right)^2 + \dots + \left(\frac{\sigma_A}{A} \right)^2 + \left(\frac{\sigma_p}{q_V} \right)^2 \right]^{1/2} \right\} = q_V \left(1 \pm 2 \frac{\sigma_{q_V}}{q_V} \right) \quad (27)$$

at the 95 % confidence level, where

- σ_v is the standard deviation on local velocity measurements, calculated as described in 13.6.1;
- σ_i is the standard deviation arising from the use of the integration technique;
- σ_m is the standard deviation associated with the estimation of the value of m ;
- σ_l is the standard deviation arising from Pitot tube positioning;
- σ_A is the standard deviation on the evaluation of the measuring cross-section area;

NOTE It should be noted that the coefficient of variation in the evaluation of the measuring cross-section area is twice the coefficient of variation on the length measurement from which the area is calculated.

- σ_p is the standard deviation arising from the number of velocity measuring points.

Annex A (normative)

Pitot tubes

A.1 Different types

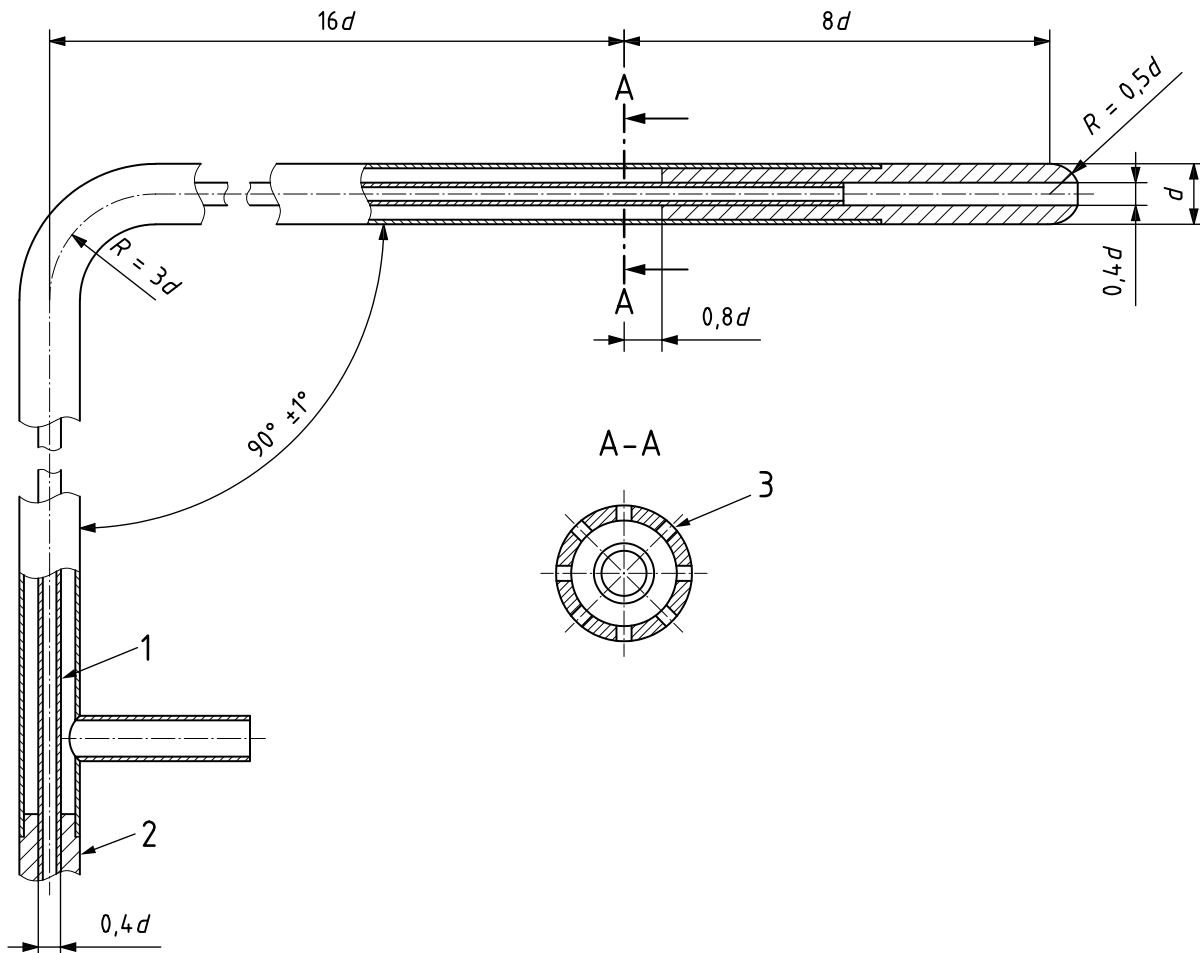
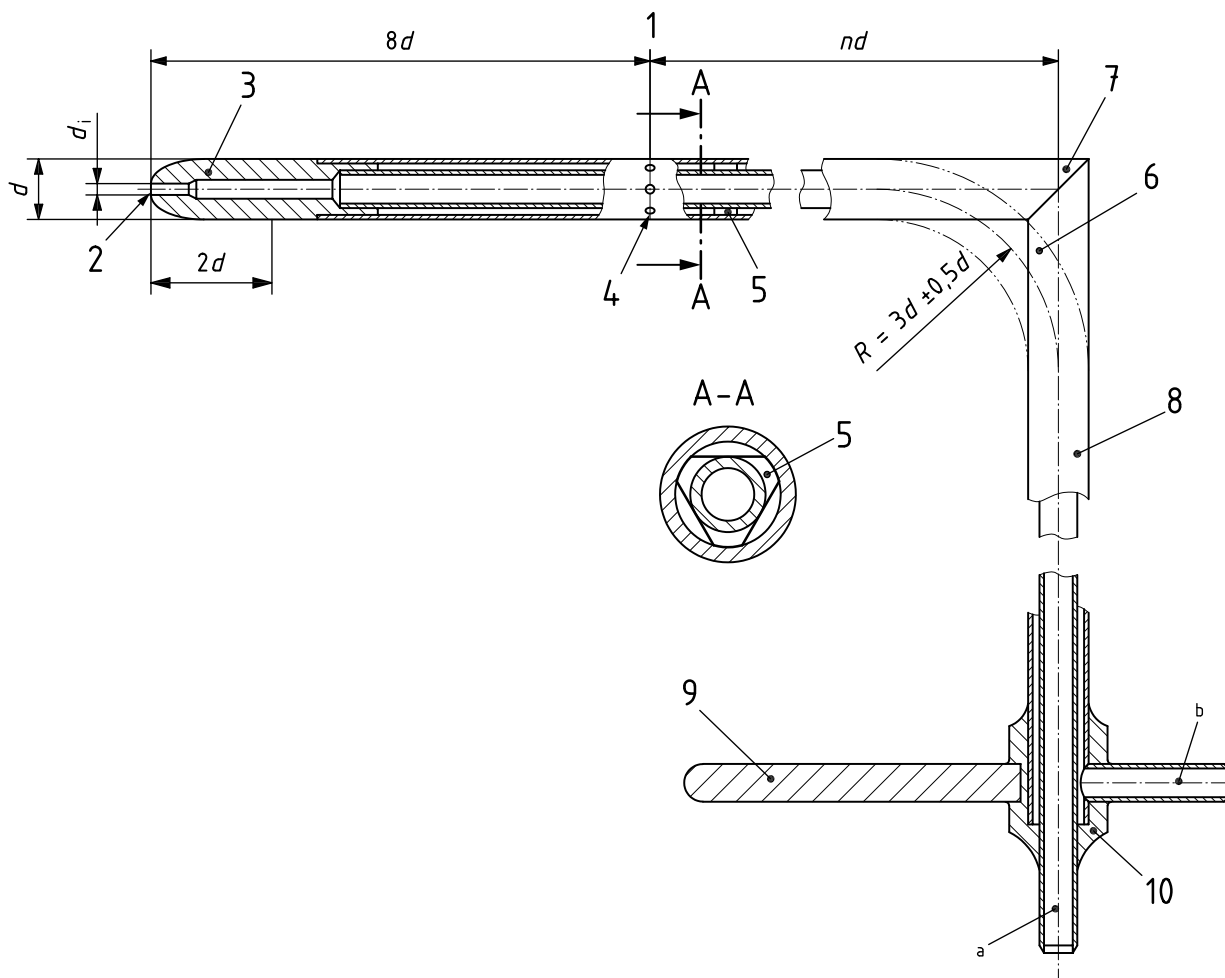

Figure A.1 — AMCA type



Key

- | | | | |
|---|---------------------------|----|-----------------------------|
| 1 | head | 6 | alternative curved junction |
| 2 | total pressure hole | 7 | mitred junction |
| 3 | modified ellipsoidal nose | 8 | stem |
| 4 | static pressure holes | 9 | alignment arm |
| 5 | spacer | 10 | pressure tapping |
| a | Total pressure. | | |
| b | Static pressure. | | |

Figure A.2 — NPL type with modified ellipsoidal nose

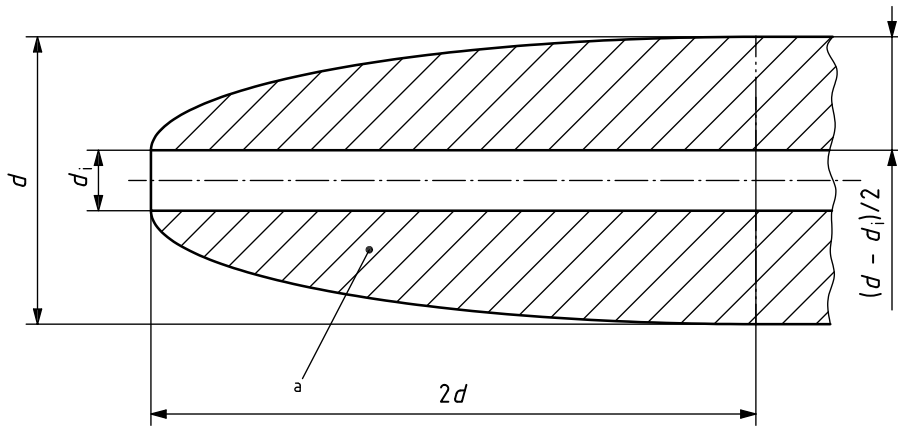

^a Quarter-ellipse.

Figure A.3 — Profile definition of the ellipsoidal head

Nose profile:

Two quarter-ellipses with major semi-axes $2d$, minor semi-axes $0,5(d - d_i)$, separated by distance d_i .

Diameter, d :

Shall not exceed 15 mm.

Total-pressure hole:

Diameter, d_i , within range $0,10d \leq d_i \leq 0,35d$ ⁶⁾. This diameter shall not change within $1,5d_i$ from tip.

Static-pressure holes:

Diameter d_s shall not exceed 1 mm; depth of hole not less than $0,5d_s$; number of holes not less than six; plane of holes at distance $8d$ from tip of nose.

Stem:

Diameter constant and equal to d ; junction curved with mean radius $3d \pm 0,5d$, or mitred; axis of stem to be nd from plane of static-pressure holes, where $n \geq 8$.

Calibration factor (defined in [8.2](#)):

Values within $\pm 0,002$ given in [Table A.1](#).

Table A.1

n	8	10	12	14	16	∞
Curved junction	1,001 5	1,001 5	1,001	1,001	1,000 5	0,998
Mitred junction	1,003	1,002	1,001 5	1,001	1,000 5	0,998

6) The larger diameter holes are intended to be used with tubes of small diameter, to extend the lower velocity range without introducing viscous effects in the hole.

A.2 Sensitivity of Pitot tube to inclination

When the axis of the head of a Pitot tube under use is not aligned with the mean flow direction but forms an angle φ with it, the differential pressure recorded, Δp_φ , is different from the true differential pressure, Δp_o .

However, some shapes of tip (and this is the case for the three types described above) may reduce the value $(\Delta p_\varphi - \Delta p_o)$ within a wide range of values of angle, φ .

[Figure A.5](#) gives the values of $(\Delta p_\varphi - \Delta p_o)/\Delta p_o$ for these three types of tube.

NOTE The values given by the curves below depend slightly on the value of the Reynolds number of the flow related to the outer diameter, d , of the Pitot tube, Re_d . This variation, which arises from the response of the static pressure tap, is practically identical for the three Pitot tubes under consideration.

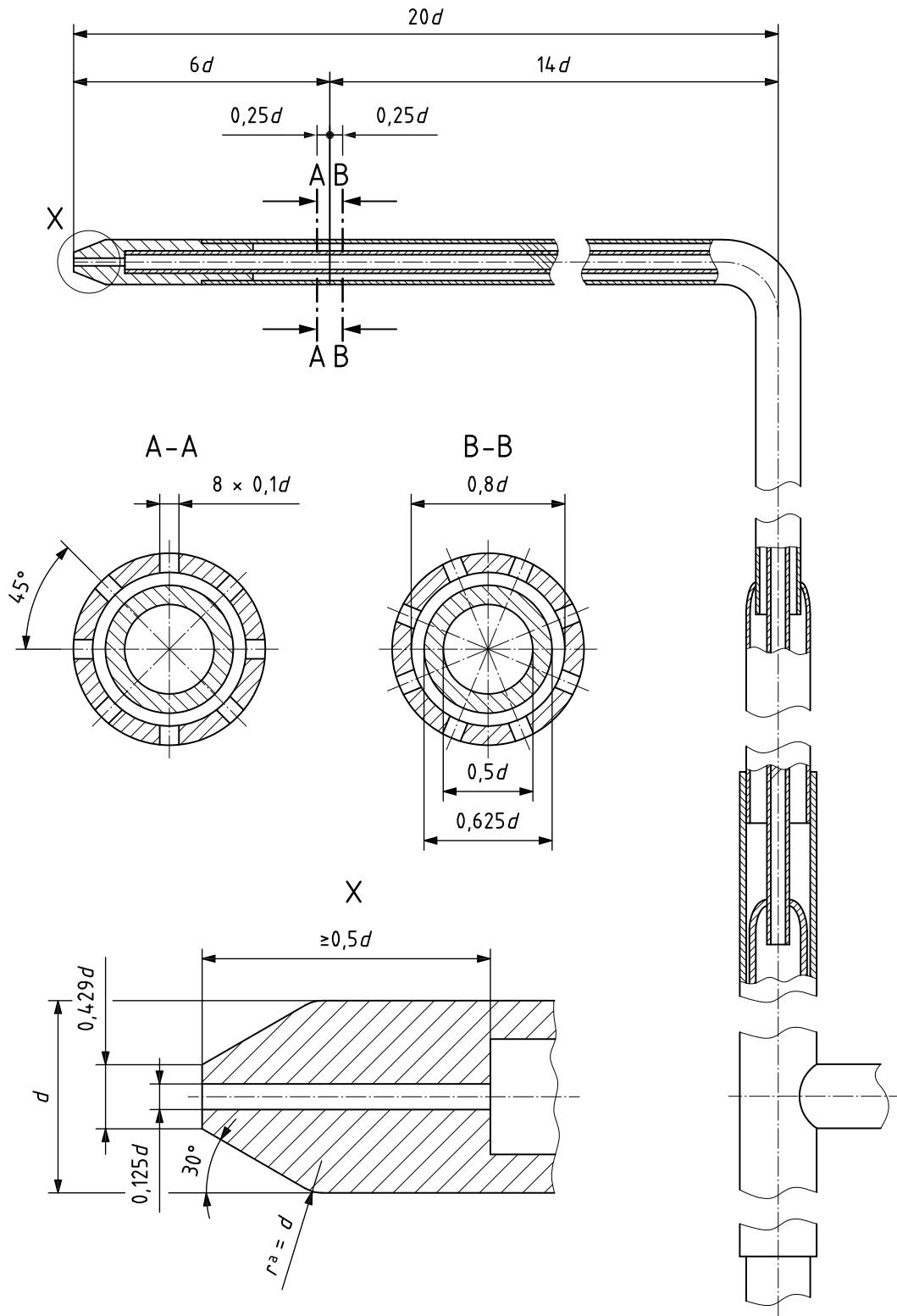

^a The radius is only useful when the Pitot tube is used in liquids in order to avoid cavitation (see 5.2).

NOTE Static pressure taps may be limited to those indicated on section A-A, in which case section A-A shall be placed at $6d$ from the tube tip.

Figure A.4 — CETIAT type

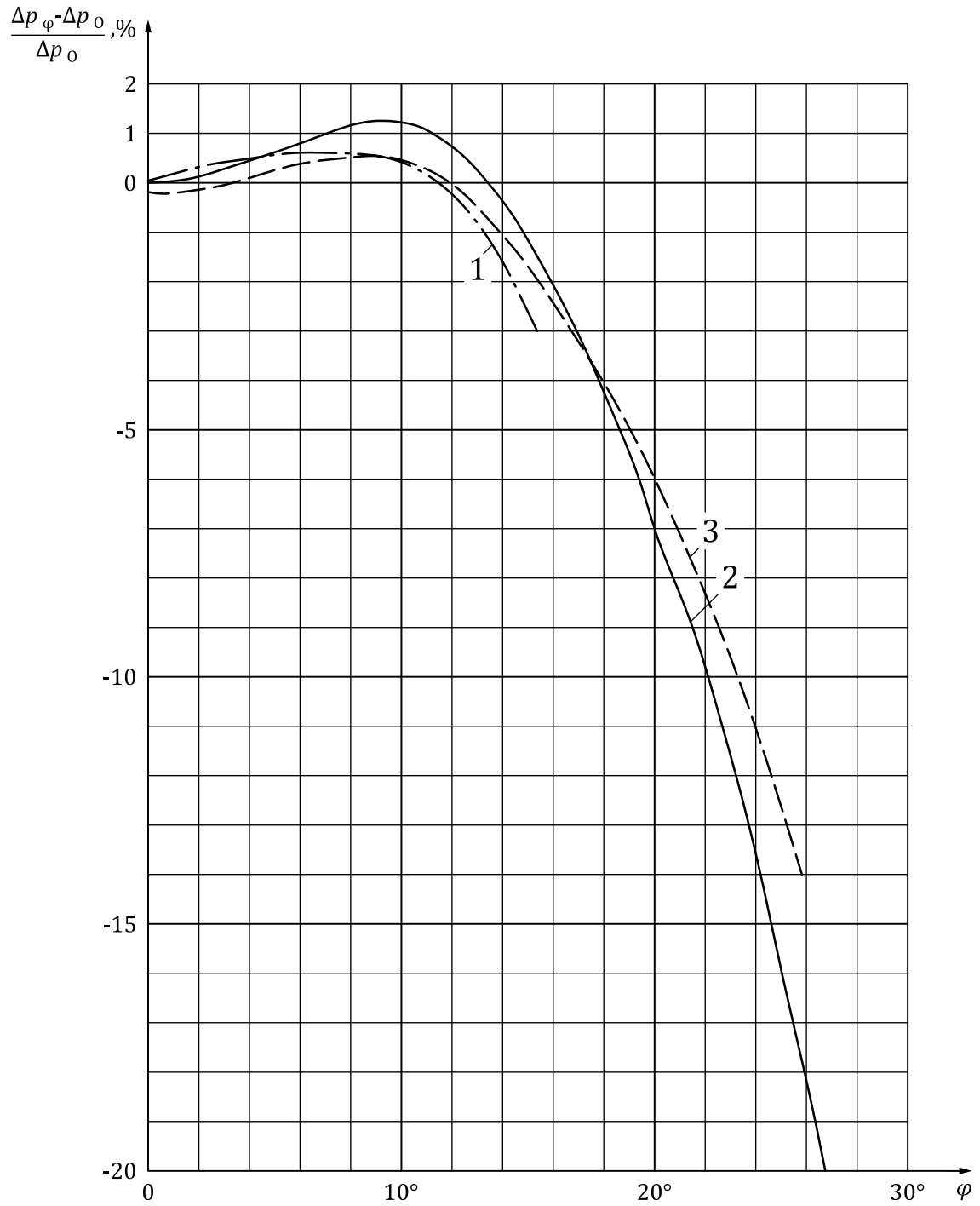

Key

- 1 AMCA type Pitot tube
- 2 NPL type Pitot tube, $Re_d = 17\ 000$
- 3 CETIAT type Pitot tube, $Re_d = 8\ 600$

Figure A.5 — Values of $(\Delta p_\phi - \Delta p_o) / \Delta p_o$

Annex B (normative)

Correction to the measuring position of Pitot tubes used in a transverse velocity gradient

B.1 Determination of the displacement of a measuring point

Provided that the measuring position is not too close to a wall, the magnitude of the displacement of streamlines due to the velocity gradient on the Pitot tube (see 12.2) is constant for a given tube, regardless of the magnitude of the velocity gradient; it is, moreover, proportional to the head diameter. Given that the magnitude of this displacement is not directly measurable, theoretical studies of the phenomenon of displacement have led to the conclusion that this displacement is proportional to the effective drag coefficient of the nose.

As the measuring position approaches a wall, the magnitude of the displacement is progressively reduced, but not eliminated, as the result of an entirely different process caused by the proximity of the tube to the wall. This proximity displacement is calculable and is also proportional to the diameter of the tube and the effective drag coefficient of the nose.

The velocity gradient displacement therefore takes the form

$$(\Delta y_1)/d = k_g \quad (\text{B.1})$$

where

d is the head diameter;

k_g is a constant dependent on the nose shape.

The wall proximity displacement is:

$$\frac{\Delta y_2}{d} = -a \left(\frac{d}{y} \right) \left[1 - \frac{1}{\sqrt{1 + \left(\frac{2}{a} \right) \left(\frac{y}{d} \right)^2}} \right] \quad (\text{B.2})$$

where

a is a constant dependent on the nose shape;

y is the distance of the axis of the head from the wall.

For the case of the plane-ended Pitot tube, experiments show that $a/k_g = 0,195$.

Because both effects depend on the effective drag coefficient of the nose, and because a is much smaller than k , the combined velocity gradient and wall proximity displacement of other tubes may also be written, with sufficient accuracy for the present purpose, in the form:

$$\frac{\Delta y}{d} = k_g - 0,195 k_g \left(\frac{d}{y} \right) \left[1 - \frac{1}{\sqrt{1 + \left(\frac{10,24}{k_g} \right) \left(\frac{y}{d} \right)^2}} \right] \quad (\text{B.3})$$

B.2 Determination of the overall correction for flow rate in a circular conduit

In the case of arithmetic methods, instead of applying a correction to the position of the measuring points, it can suffice to calculate an overall correction for the volume rate of flow taking account of the various displacements due to the velocity gradient and the wall proximity. From the total displacement of a particular measuring point calculated as mentioned above, assuming a velocity profile of the form:

$$\left(\frac{v}{v_{\max}} \right) = \left(\frac{y}{R} \right)^{1/m} \quad (\text{B.4})$$

the effect of the velocity gradient is expressed by a relative variation of the measured velocity in each measuring point:

$$\frac{\delta(v/v_{\max})}{(v/v_{\max})} = \frac{1}{m} \frac{(\Delta y/d)(d/D)}{(y/D)} \quad (\text{B.5})$$

The variation of the discharge velocity is the mean of individual variations in each prescribed measuring point:

$$\delta \left(\frac{U}{v_{\max}} \right) = \frac{1}{m} \frac{d}{D} \frac{1}{i} \sum_1^i \frac{\Delta y/d}{y/D} \frac{v}{v_{\max}} \quad (\text{B.6})$$

The discharge velocity is given by:

$$\frac{U}{v_{\max}} = \frac{1}{i} \sum_1^i \frac{v}{v_{\max}} \quad (\text{B.7})$$

The relative variation of the measured flow rate is therefore:

$$\frac{\delta q_V}{q_V} = \frac{1}{m} \frac{d}{D} \frac{\sum_1^i \frac{\Delta y/d}{y/D} \frac{v}{v_{\max}}}{\sum_1^i \frac{v}{v_{\max}}} \quad (\text{B.8})$$

This expression was used to derive [Figure 7](#) (see [12.2.2](#)).

Annex C (normative)

Study concerning turbulence correction

C.1 Influence of turbulence on the total pressure tap

C.1.1 Pressure probe insensitive to orientation

If a pressure probe which is insensitive to orientation is placed in a turbulent flow, this probe will at all times receive the total pressure p_{ti} given (see [Figure C.1](#)) by:

$$p_{ti} = p_i + \frac{1}{2} \rho v_i^2 \tag{C.1}$$

where

p_i is the instantaneous static pressure;

v_i is the instantaneous velocity;

ρ is the fluid density.

$$v_i = \bar{v} + \bar{v}'_x + \bar{v}'_y + \bar{v}'_z$$

in which

\bar{v}'_x , \bar{v}'_y and \bar{v}'_z are the components of the velocity fluctuation;

\bar{v} is the mean velocity.

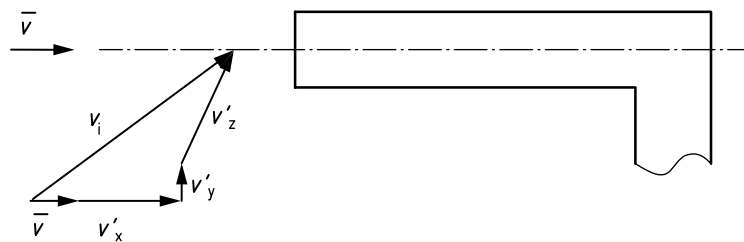

Figure C.1 — Pressure probe insensitive to orientation

This is not, however, the value which, in general, it is desired to obtain.

If the damping achieved by the ducts and the pressure gauge is correct, a p_t value is obtained, such that:

$$\bar{p}_t = \frac{1}{t} \int_0^t p_{ti} dt \quad (C.2)$$

with

$$\bar{p}_t = \bar{p} + \frac{1}{2} \rho \bar{v}^2 + \frac{1}{2} \rho \left(\overline{v_x'^2} + \overline{v_y'^2} + \overline{v_z'^2} \right) \quad (C.3)$$

where

$$\bar{p} = \frac{1}{t} \int_0^t p_i dt \quad (C.4)$$

The correct determination of \bar{v} , which is a necessary step in the rate of flow calculation, demands:

- a) knowledge of the mean pressure, \bar{p} , at each measuring point;
- b) knowledge of the values $\overline{v_x'^2}$, $\overline{v_y'^2}$ and $\overline{v_z'^2}$.

C.1.2 Pressure probe sensitive to orientation

In the case where the total-pressure tapping nose is sensitive to orientation, flow turbulence introduces an error into the measurement read at the total-pressure tap even when the Pitot tube is parallel to the conduit axis.

C.2 Influence of turbulence on the static-pressure tap

The influence of turbulence in this case is a very much more complex problem.

Up to now, it has always been assumed that there is a relationship in the form of:

$$\bar{p}_m = \bar{p} + k_s \rho \left(\overline{v_y'^2} + \overline{v_z'^2} \right) \quad (C.5)$$

where

\bar{p}_m is the mean measured pressure;

\bar{p} is the mean actual pressure;

k_s is a factor of the order of 1/4.

It has, however, been proved that in most cases we have a relationship in the form of:

$$\bar{p}_m = \bar{p} - k_t \frac{\rho}{2} \left(\overline{v_y'^2} + \overline{v_z'^2} \right) \quad (C.6)$$

where k_t is a factor of the order of 0,6 for a conventional cylindrical probe of diameter, d , relatively small in comparison with a correlation length, L , characterizing the turbulent flow under study. This is nearly always the case for industrial types of flow.

Combining [Formulae \(C.1\)](#) and [\(C.3\)](#) gives:

$$\frac{1}{2} \rho v^2 = \bar{p}_t - \frac{1}{2} \rho \left(\overline{v_x'^2} + \overline{v_y'^2} + \overline{v_z'^2} \right) - \bar{p}_m - k_t \rho \left(\overline{v_y'^2} + \overline{v_z'^2} \right) \quad (C.7)$$

C.3 Evaluation of errors for an exploration with a Pitot tube

Some evaluations of the errors have been made by using the values $\sqrt{\overline{v_x'^2}}$, $\sqrt{\overline{v_y'^2}}$, $\sqrt{\overline{v_z'^2}}$, corresponding to steady flow in a long conduit.

For this estimation, it has been erroneously assumed that one had the relation $\bar{p}_m = \bar{p} + k_s \rho (\overline{v_y'^2} + \overline{v_z'^2})$ with $k_s = 0,25$, which minimizes the error on the determination of the mean local velocity.

Some authors state for

$$Re_D = \frac{UD}{\nu} = 40\,000 \quad (\text{C.8})$$

$\Delta q_V/q_V = 0,54\%$ (this positive error seems underestimated for the reasons mentioned above).

For the same Reynolds number, these authors computed the error resulting from the use of a Pitot tube situated at a distance $(y_n)_{Re=40\,000} = 0,235 (D/2)$ from the wall (three-quarter radius flow meter, the distance at which the measured velocity should be equal to the mean flow velocity), i.e.

$$\frac{\Delta q_V}{q_V} = 0,50\% \quad (\text{C.9})$$

As this result closely approximates the previous result relating to a more complete computation, these authors assume that the error thus calculated is characteristic for the entire range of Reynolds numbers under consideration; they provide the following table:

Re	4×10^4	7×10^4	10^5	2×10^5	5×10^5	10^6	3×10^6	10^7	3×10^7
$(\Delta v/v)_{(y_m)_{Re}} \approx \Delta q_V/q_V$	0,005 0	0,004 3	0,004 0	0,003 5	0,002 9	0,002 6	0,002 2	0,001 8	0,001 5

These limits of error actually seem to be rather low in view of the accepted type of correction regarding static pressure probes, and values given in [12.3](#) seem to be more realistic.

Annex D (normative)

Damping of pressure gauges

It is often necessary, in order to facilitate reading the pressure gauge, that the differential pressure random fluctuations shall be damped without, however, concealing longer term fluctuations or falsifying the time average of the fluctuating pressure. The damping of the apparatus shall therefore be symmetrical and linear. When a sudden change in pressure is applied, the pressure indicator shall register 99 % of that change in not more than 60 s. Damping shall not be used to conceal regular pulsations of the pressure which render the measurement beyond the scope of this document.

D.1 Damping procedure

Damping of the apparatus shall be effected using a resistance which is linear (i.e. proportional to the velocity) and symmetrical. Thus every precaution shall be taken to avoid bending or pinching the rubber connecting pipes. Asymmetric nozzles, needle valves or gate valves, shall not be inserted between the Pitot tube and the pressure gauge.

A capillary tube of adequate length (e.g. 1 mm in diameter and 100 mm in length if water is used as a manometric fluid) shall be incorporated preferably in one of the manometer limbs (to ensure complete tightness of the connection) or in one of the leads close to the manometer and care shall be taken to avoid any sudden reduction or expansion of the connecting pipe which would involve an appreciable head loss in comparison with the loss due to the capillary tube.

D.2 Balancing of the damping

When the time constant of the pressure gauge is of the same order of magnitude as those of the two connecting circuits (from the static-pressure tapping to the pressure gauge on the one hand and from the total-pressure tapping to the pressure gauge on the other), it is necessary to balance the damping of the two circuits and it may therefore be of interest to use the device described in Reference [\[1\]](#).

When the time constant of the pressure gauge is sensibly higher than those of the two circuits, the damping balancing is not compulsory.

D.3 Checking of the damping

To try to make sure that the pressure gauge resistance is linear (i.e. its operation then corresponds to a flow in the connections which is laminar), check that the observed fluctuations correspond (for sinusoidal pulses) to a maximum fictitious Reynolds number well under 2 000. This fictitious Reynolds number is equal to

$$\frac{\pi S \Delta h}{s t v_{kv} d} \tag{D.1}$$

where

S is the surface area of the meniscus;

s is the minimum section of the capillary tube used to damp the pressure gauge;

d is the diameter of the capillary tube;

Δh is the peak-to-peak magnitude of a fluctuation of the meniscus level;

t is the period of this fluctuation;

ν_{kv} is the kinematic viscosity (Greek ν) of the fluid.

In order to check the damping more rigorously, a controllable source of fluctuating pressure (which can cause a sinusoidal pressure difference of sufficient amplitude and of zero mean value) shall be used. The mean position of oscillation of the meniscus then corresponds to the rest position (in the absence of driving pressure) if the resistance is actually symmetrical and linear.

Annex E (normative)

Measurements with a Pitot tube in a compressible fluid

E.1 General

As pointed out in [8.1](#), the formulae for velocity calculation given in [8.2](#) are valid for a compressible fluid only if the velocity is rather low and more precisely if the Mach number is less than 0,25.

When the speed of a fluid is great enough to cause compressibility to sensibly affect the total pressure indicated by the Pitot tube, the isentropic flow formulae should be used. Pitot static tubes as described in this document cannot generally be used at Mach numbers greater than about 0,8 and for best accuracies should be calibrated under the conditions in which they will be used. At Mach numbers between 0,9 to 1,0 most tubes of this type show anomalous behaviour, so measurements cannot be made. In addition, these types of tubes are then more sensitive to misalignment with the flow direction so that it becomes more important that the swirl of the stream be minimized and that the transverse static pressure distribution be uniform to ensure axial flow. In supersonic flow, these types of instruments should not be used to determine velocity. In this case, the pressure should be measured with a probe which indicates true local pressure, and the determination of the total pressure requires the use of the normal shock relationships to evaluate the measurements with the Pitot tube.

E.2 List of subscripts used in this annex

- o* stagnation conditions
- c* at stream centreline
- w* at the wall

E.3 Determination of velocity calculation

In compressible flow, the relationship

$$v = \alpha \left(\frac{2\Delta p}{\rho} \right)^{\frac{1}{2}} \tag{E.1}$$

does not apply without a compressibility correction factor.

Assuming no losses, the true velocity, v , of a stream of a compressible fluid in a uniform flow remote from a boundary surface is given by [Formula \(E.2\)](#):

$$v = \alpha \left\{ \left(\frac{2\gamma}{\gamma-1} \frac{p}{\rho} \right) \left[\left(\frac{p_0}{p} \right)^{\frac{\gamma-1}{\gamma}} - 1 \right] \right\}^{1/2} \quad (\text{E.2})$$

which may be written in the form

$$v = \alpha \left(\frac{2\Delta p}{\rho} \right)^{1/2} (1 - \varepsilon) \quad (\text{E.3})$$

or alternatively

$$v = \alpha (1 - \varepsilon) \left(\frac{2\Delta p Z R T}{p M} \right)^{1/2} \quad (\text{E.4})$$

in which $1 - \varepsilon$ is a compressibility correction factor which can be evaluated using several equivalent expressions, e.g. [Formula \(E.5\)](#):

$$1 - \varepsilon = \left\{ \left(\frac{\gamma}{\gamma-1} \frac{p}{\Delta p} \right) \left[\left(\frac{\Delta p}{p} + 1 \right)^{\frac{\gamma-1}{\gamma}} - 1 \right] \right\}^{1/2} \quad (\text{E.5})$$

or approximated by the series expressions,

$$1 - \varepsilon = \left[1 - \frac{1}{2\gamma} \left(\frac{\Delta p}{p} \right) + \frac{\gamma+1}{6\gamma^2} \left(\frac{\Delta p}{p} \right)^2 - \frac{(\gamma+1)(2\gamma+1)}{24\gamma^3} \left(\frac{\Delta p}{p} \right)^3 + \dots \right]^{1/2} \quad (\text{E.6})$$

or alternatively,

$$1 - \varepsilon = \left[1 + \frac{Ma^2}{4} + \frac{2-\gamma}{24} Ma^4 + \frac{(2-\gamma)(3-2\gamma)}{192} Ma^6 + \dots \right]^{-1/2} \quad (\text{E.7})$$

in which

$$Ma = \left\{ \frac{2}{\gamma-1} \left[\left(\frac{\Delta p}{p} + 1 \right)^{\frac{\gamma-1}{\gamma}} - 1 \right] \right\}^{1/2} \quad (\text{E.8})$$

To determine the velocity from [Formula \(E.4\)](#), Δp and p are measured directly and the remaining unknown is the local static temperature, T . The static temperature generally cannot be measured directly by any instrument introduced into the flow. The interaction of the flow with the probe causes some of the kinetic energy of the stream in the immediate vicinity of the probe to be converted into thermal energy; but special shielded stagnation thermometers are available which indicate T_0 with only a small error. This can be corrected to true stagnation temperature by applying the predetermined calibration factor. Any other equilibrium temperature probe, calibrated to determine its recovery factor, could likewise be used to determine stagnation temperature; but since the recovery factor of any such instrument is a function of velocity, this can be done only by some iterative process. After the true

stagnation temperature has been determined, the local static temperature, T , can be computed using [Formula \(E.9\)](#).

$$\frac{T_0}{T} = 1 + \frac{\gamma - 1}{2} Ma^2 \quad (\text{E.9})$$

To eliminate the difficult computations indicated by these expressions, Ma , T/T_0 , and $1 - \varepsilon$ are tabulated in [Table E.1](#), with $\Delta p/p$ as the argument and γ as a parameter.

For the best accuracy in determining velocity, the stream temperature should be determined at each measuring point, but if no heat transfer occurs, the temperature profile can be approximated with temperature measurements only at the conduit centreline and the wall. [Formulae \(E.10\)](#) and [\(E.11\)](#) then apply:

$$\frac{T - T_C}{T} = K(\Delta p_C - \Delta p) \quad (\text{E.10})$$

in which

$$K = \frac{T_W - T_C}{T_W \Delta p_C} \quad (\text{E.11})$$

E.4 Operating procedure

To determine the velocity profile in a closed conduit with compressible flow, the following procedure shall be used:

Measurements:

- a) Measure Δp at each measurement point.
- b) Measure p at each measurement point. These measurements should be examined for abnormalities. The pressure at a given cross-section should be sensibly constant; any differences may indicate a possible swirling or other non-uniform flow condition so that measurements at this station become suspect.
- c) Measure or determine stagnation temperature on the conduit centreline.
- d) Measure or determine the interior conduit wall temperature.

Computations:

- 1) Compute $\Delta p/p$ at each measurement point.
- 2) Determine the Mach number at the conduit centreline.
- 3) Determine the free stream temperature at conduit centreline.
- 4) Measure or compute the free stream temperature for each measuring point using [Formulae \(E.10\)](#) and [\(E.11\)](#).
- 5) Determine compressibility correction factors from [Table E.1](#) at each measuring point.
- 6) Compute velocity at each measurement point, using [Formula \(E.4\)](#).

Table E.1 — Compressibility correction factors

$\Delta p/p$	1,1		1,2		1,3		1,4		1,5		1,6		1,7	
	Ma	$1 - \varepsilon$	Ma	T/T_0	Ma	T/T_0	Ma	T/T_0	Ma	T/T_0	Ma	T/T_0	Ma	T/T_0
0,01	0,135	0,999	0,129	0,998	0,124	0,998	0,119	0,997	0,115	0,997	0,112	0,996	0,108	0,996
0,02	0,190	0,998	0,182	0,997	0,175	0,995	0,168	0,994	0,163	0,993	0,158	0,993	0,153	0,992
0,03	0,232	0,997	0,222	0,995	0,214	0,993	0,206	0,992	0,199	0,990	0,193	0,989	0,187	0,988
0,04	0,267	0,996	0,256	0,994	0,246	0,991	0,237	0,989	0,229	0,987	0,222	0,985	0,216	0,984
0,05	0,298	0,996	0,286	0,992	0,275	0,989	0,265	0,986	0,256	0,984	0,248	0,982	0,241	0,980
0,06	0,326	0,995	0,312	0,990	0,300	0,987	0,290	0,984	0,280	0,981	0,271	0,978	0,263	0,976
0,07	0,351	0,994	0,337	0,989	0,324	0,985	0,312	0,981	0,302	0,978	0,293	0,975	0,284	0,973
0,08	0,375	0,993	0,359	0,987	0,346	0,982	0,333	0,978	0,322	0,975	0,312	0,972	0,303	0,969
0,09	0,397	0,992	0,380	0,986	0,366	0,980	0,353	0,976	0,341	0,972	0,331	0,968	0,321	0,965
0,10	0,417	0,991	0,400	0,984	0,385	0,978	0,372	0,973	0,359	0,969	0,348	0,965	0,338	0,962
0,20	0,578	0,984	0,555	0,970	0,535	0,959	0,517	0,949	0,501	0,941	0,486	0,934	0,472	0,928
0,30	0,695	0,976	0,669	0,957	0,645	0,941	0,624	0,928	0,605	0,916	0,587	0,906	0,571	0,898
0,40	0,788	0,970	0,760	0,945	0,734	0,925	0,710	0,908	0,689	0,894	0,670	0,882	0,652	0,871
0,50	0,867	0,964	0,836	0,935	0,809	0,911	0,784	0,891	0,761	0,874	0,740	0,859	0,721	0,846
0,60	—	—	—	—	—	—	0,848	0,874	0,824	0,855	0,802	0,838	0,781	0,824
0,70	—	—	—	—	—	—	—	—	—	—	0,857	0,820	0,835	0,804

$Ma = \left\{ \frac{2}{\gamma - 1} \left[\left(\frac{\Delta p}{p} + 1 \right) \frac{\gamma - 1}{\gamma} - 1 \right] \right\}^{1/2}$	$\frac{T}{T_0} = \left(1 + \frac{\gamma - 1}{2} Ma^2 \right)^{-1}$	$1 - \varepsilon = \left\{ \frac{\gamma}{\gamma - 1} \frac{p}{\Delta p} \left[\left(\frac{\Delta p}{p} + 1 \right) \frac{\gamma - 1}{\gamma} - 1 \right] \right\}^{1/2}$
---	---	--

Annex F (normative)

Determination of coefficient m for extrapolation near the wall

F.1 Method of determination of m

To calculate the discharge velocity in the peripheral zone, coefficient, m , can be determined graphically from the measured velocities and traverse positions, corrected for the displacement effect according to [12.2.1.1](#).

Plot, on log-log co-ordinates, the curve of the measured point velocities against the distance to the wall ([Figure F.1](#)). In the zone near the wall, this curve is a straight line of slope $1/m$.

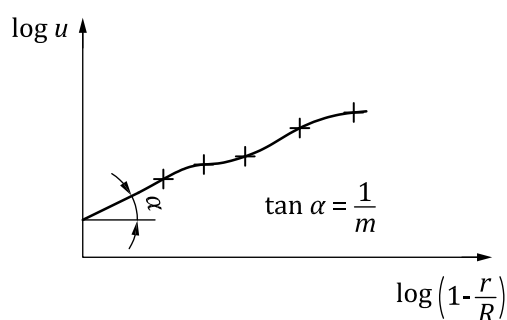

Figure F.1 — Curve of the measured point velocities against the distance to the wall

The two measuring points situated nearest to the wall shall comply with the following requirements:

- the first point shall be placed as close as possible to the wall, and in any case at a distance not greater than $0,03l$ (l being the smallest transverse dimension of the cross-section) taking account, however, of the minimum distance equal to the diameter of the stem, to be respected between the Pitot tube axis and the wall;
- the second point shall be placed at a greater distance from the wall than the previous one, this distance being, however, kept equal to or less than $0,08l$. In any case, the measured velocity at this point should be less than $0,7$ times the maximum velocity in the section.

F.2 Influence on the calculation of discharge velocity

Bad assessment of coefficient m leads to reversing of the tangent at the last measuring point, thus resulting in partial compensation of errors on flow rate on either side of this point. On the other hand, the error rapidly decreases with the relative importance of the peripheral zone (i.e. when the cross-section dimensions increase or the Pitot tube dimensions decrease).

In so far as the two measuring points close to the wall allow determination of m , the error due to the selection of coefficient m is considerably reduced and considered as negligible.

Annex G (informative)

Example of calculation of the uncertainty on the flow-rate measurement by means of Pitot tubes

The values of the errors shall be estimated by the user of this document for each particular case.

The calculation below is an example based on the estimations of the different errors made during a flow-rate measurement carried out under normal conditions. The values used are for the purposes of illustration only and shall not be regarded as typical.

On the other hand, it is assumed in the calculation that the various corrections considered in [Clause 12](#) have not been made.

G.1 Error on the local velocity measurement

- Standard deviation of error arising from measurement of differential pressure: for measurements made with a good industrial quality apparatus it can be assumed for example that:

$$\frac{\sigma_{\Delta p}}{\Delta p} = 0,004$$

- Standard deviation arising from the determination of density:

$$\frac{\sigma_{\rho}}{\rho} = 0,002$$

- Standard deviation of error arising from slow fluctuations of the velocity: if the amplitude of the fluctuations is $a = 0,01v_v$, it can be assumed that:

$$\frac{\sigma_f}{v} = 0,001$$

- Standard deviation of error arising from compressibility correction:

$$\frac{\sigma_{\varepsilon}}{v} = 0,001$$

- Standard deviation of error arising from calibration:

$$\frac{\sigma_c}{v} = 0,002$$

- Standard deviation of error arising from high-frequency fluctuations and turbulence: according to [12.3](#) it can be:

$$\frac{\sigma_t}{v} = 0,005$$

- Standard deviation of error arising from gradient velocity: for a Pitot tube the diameter of which is equal to 1/50 of the conduit diameter, it can be, according to [12.2](#):

$$\frac{\sigma_g}{v} = 0,0015$$

- Standard deviation of error arising from blockage effect: in the same conditions and according to [12.1](#):

$$\frac{\sigma_b}{v} = 0,0025$$

- Standard deviation of error arising from Pitot tube inclination: for an orientation defect of 3° and according to [A.2](#), it could be:

$$\frac{\sigma_\varphi}{v} = 0,0015$$

- Standard deviation of error arising from head loss: assuming always $d/D = 0,02$ and for $\lambda = 0,05$, it can be approximately, according to [12.4](#):

$$\frac{\sigma_\xi}{v} = 0,002$$

The standard deviation on the local velocity measurement is therefore:

$$\frac{\sigma_v}{v} = \sqrt{\left(\frac{1}{4} \times 16\right) + \left(\frac{1}{4} \times 4\right) + 1 + 1 + 4 + 25 + 2,25 + 6,25 + 2,25 + \left(\frac{1}{4} \times 4\right)} \times 10^{-3} \approx 0,007$$

G.2 Error on the flow-rate measurement

- Standard deviation of error on the measurement of local velocities from [G.1](#):

$$\frac{\sigma_v}{v} = 0,007$$

- Standard deviation of error arising from the integration technique: for the minimum authorized number of measuring points, it could not be greater than:

$$\frac{\sigma_i}{q_V} = 0,001$$

- Standard deviation of error arising from the estimation of m :

$$\frac{\sigma_m}{q_V} = 0,0005$$

- Standard deviation of error arising from the Pitot tube positioning: if positioning tolerances given in [4.4.1](#) are followed, it can be assumed:

$$\frac{\sigma_l}{q_V} = 0,0005$$

- Standard deviation of error on the area measurement:

$$\frac{\sigma_A}{A} = 0,002$$

- Standard deviation of error arising from an insufficient number of measuring points: if the flow conditions given in this document are followed, it can be assumed:

$$\frac{\sigma_p}{q_V} = 0,001$$

The standard deviation on the flow-rate measurement is therefore:

$$\frac{\sigma_{q_V}}{q_V} = \sqrt{49+1+0,25+0,25+4+1} \times 10^{-3} \approx 0,0074$$

and the rate of flow shall be determined with a tolerance, at the 95 % confidence level,

$$\delta'_{q_V} = \pm 2 \frac{\delta_{q_V}}{q_V}, \text{ i.e. } \delta'_{q_V} \approx \pm 1,5 \%$$

The final value thus obtained confirms that provided the blockage effect correction has been applied, the tolerance on a flow-rate measurement, carried out in accordance with this document, is generally less than $\pm 2 \%$.

Bibliography

- [1] ISO 7194, *Measurement of fluid flow in closed conduits — Velocity-area methods of flow measurement in swirling or asymmetric flow conditions in circular ducts by means of current-meters or Pitot static tubes*
- [2] OWER E., PANKHURST R.C., *The measurement of air flow*, 5th edition. Pergamon, Oxford, 1977. 362 p.

Bureau of Indian Standards

BIS is a statutory institution established under the *Bureau of Indian Standards Act, 2016* to promote harmonious development of the activities of standardization, marking and quality certification of goods and attending to connected matters in the country.

Copyright

BIS has the copyright of all its publications. No part of these publications may be reproduced in any form without the prior permission in writing of BIS. This does not preclude the free use, in the course of implementing the standard, of necessary details, such as symbols and sizes, type or grade designations. Enquiries relating to copyright be addressed to the Head (Publication & Sales), BIS.

Review of Indian Standards

Amendments are issued to standards as the need arises on the basis of comments. Standards are also reviewed periodically; a standard along with amendments is reaffirmed when such review indicates that no changes are needed; if the review indicates that changes are needed, it is taken up for revision. Users of Indian Standards should ascertain that they are in possession of the latest amendments or edition by referring to the website-www.bis.gov.in or www.standardsbis.in.

This Indian Standard has been developed from Doc No.: WRD 01 (20347).

Amendments Issued Since Publication

Amend No.	Date of Issue	Text Affected

BUREAU OF INDIAN STANDARDS

Headquarters:

Manak Bhavan, 9 Bahadur Shah Zafar Marg, New Delhi 110002

Telephones: 2323 0131, 2323 3375, 2323 9402

Website: www.bis.gov.in

Regional Offices:

Central : 601/A, Konnectus Tower -1, 6th Floor,
DMRC Building, Bhavbhuti Marg, New
Delhi 110002

Telephones

{ 2323 7617

Eastern : 8th Floor, Plot No 7/7 & 7/8, CP Block, Sector V,
Salt Lake, Kolkata, West Bengal 700091

{ 2367 0012
{ 2320 9474

Northern : Plot No. 4-A, Sector 27-B, Madhya Marg,
Chandigarh 160019

{ 265 9930

Southern : C.I.T. Campus, IV Cross Road, Taramani, Chennai 600113

{ 2254 1442
{ 2254 1216

Western : 5th Floor/MTNL CETTM, Technology Street, Hiranandani Gardens,
Powai, Mumbai 400076

{ 2570 0030
{ 2570 2715

Branches : AHMEDABAD, BENGALURU, BHOPAL, BHUBANESHWAR, CHANDIGARH, CHENNAI, COIMBATORE, DEHRADUN, DELHI, FARIDABAD, GHAZIABAD, GUWAHATI, HARYANA (CHANDIGARH), HUBLI, HYDERABAD, JAIPUR, JAMMU, JAMSHEDPUR, KOCHI, KOLKATA, LUCKNOW, MADURAI, MUMBAI, NAGPUR, NOIDA, PARWANOO, PATNA, PUNE, RAIPUR, RAJKOT, SURAT, VIJAYAWADA.