

भूवस्त्रादि और भूवस्त्रादि से संबंधित
उत्पाद — भार के बिना, समतल के लंबवत
जल पारगम्यता गुणधर्मों का निर्धारण
(पहला पुनरीक्षण)

**Geotextiles and Geotextile-related
Products — Determination of Water
Permeability Characteristics Normal
to the Plane, Without Load**
(*First Revision*)

ICS 59.080.70

© BIS 2024

© ISO 2019



भारतीय मानक ब्यूरो
BUREAU OF INDIAN STANDARDS
मानक भवन, 9 बहादुर शाह ज़फर मार्ग, नई दिल्ली - 110002
MANAK BHAVAN, 9 BAHADUR SHAH ZAFAR MARG
NEW DELHI - 110002
www.bis.gov.in www.standardsbis.in

NATIONAL FOREWORD

This Indian Standard (First Revision) which is identical to ISO 11058 : 2019 'Geotextiles and geotextile-related products — Determination of water permeability characteristics normal to the plane, without load' issued by the International Organization for Standardization (ISO) was adopted by the Bureau of Indian Standards on recommendation of the Geosynthetics Sectional Committee and approval of the Textiles Division Council.

This standard was first published in 1995. This revision has been brought out to align it with the latest version of ISO 11058 : 2019.

Temperature of (20 ± 2) °C as specified in International Standards is not suitable for tropical countries like India where the atmospheric temperature is normally much higher than 20 °C. It is almost impossible to maintain this temperature specially during summer when the atmospheric temperature rises even up to 50 °C. In view of the above, IS 6359 : 2023 'Method for conditioning of textiles (*first revision*)' which specifies a temperature of (27 ± 2) °C for conditioning of the test specimens for the tropical countries like India shall be referred.

The text of ISO Standard has been approved as suitable for publication as an Indian Standard without deviations. Certain conventions are, however, not identical to those used in Indian Standards. Attention is particularly drawn to the following:

- a) Wherever the words 'International Standard' appear referring to this standard, they should be read as 'Indian Standard'; and
- b) Comma (,) has been used as a decimal marker while in Indian Standards, the current practice is to use a point (.) as the decimal marker.

In this adopted standard, reference appears to certain International Standards for which Indian Standards also exist. The corresponding Indian Standards which are to be substituted in their respective places are listed below along with their degree of equivalence for the editions indicated:

<i>International Standard</i>	<i>Corresponding Indian Standard</i>	<i>Degree of Equivalence</i>
ISO 5813 Water quality — Determination of dissolved oxygen — Iodometric method	IS 3025 (Part 38) : 1989 Water and wastewater — Methods of sampling and test (physical and chemical): Part 38 Dissolved oxygen (<i>first revision</i>)	Identical
ISO 9862 Geosynthetics — Sampling and preparation of test specimens	IS 14706 : 2024/ISO 9862 : 2023 Geotextiles — Sampling and preparation of test specimens (<i>first revision</i>) (under publication)	Identical
ISO 10320 Geosynthetics — Identification on site	IS 17421 : 2020/ISO 10320 : 2019 Geosynthetics — Identification on site	Identical

The Committee has reviewed the provisions of the following International Standard referred in this standard intended to be adopted and has decided that these are acceptable for use in conjunction with this standard:

<i>International Standard</i>	<i>Title</i>
ISO 2854	Statistical interpretation of data — Techniques of estimation and tests relating to means and variances

[*\(Continued on third cover\)*](#)

Contents

Page

1	Scope	1
2	Normative references	1
3	Terms and definitions	1
4	Test specimens	1
	4.1 Handling.....	1
	4.2 Selection.....	1
	4.3 Number and dimensions.....	2
	4.4 Specimen conditions.....	2
5	Constant head method	2
	5.1 Principle.....	2
	5.2 Apparatus.....	2
	5.3 Procedure.....	3
	5.4 Calculation and expression of results.....	4
6	Falling head method	4
	6.1 Principle.....	4
	6.2 Apparatus.....	5
	6.3 Procedure.....	6
	6.4 Calculation and expression of results.....	6
7	Test report	7
Annex A (informative) Determination of the correction factor, R_T, to a water temperature of 20 °C		11
Annex B (normative) Relationship between head loss and flow velocity		13
Annex C (informative) Individual velocity index values for a head loss of 50 mm		15
Annex D (informative) Experimental data and calculations		16

Indian Standard

GEOTEXTILES AND GEOTEXTILE-RELATED PRODUCTS —
DETERMINATION OF WATER PERMEABILITY
CHARACTERISTICS NORMAL TO THE PLANE, WITHOUT LOAD

(*First Revision*)

1 Scope

This document specifies two test methods for determining the water permeability characteristics of a single layer of geotextile or geotextile-related product normal to the plane:

- a) the constant head method; and
- b) the falling head method.

2 Normative references

The following referenced documents are referred to in such a way that some or all of their content constitutes requirements of this document. For dated references, only the edition cited applies. For undated references, the latest edition of the referenced document (including any amendments) applies.

ISO 2854, *Statistical interpretation of data — Techniques of estimation and tests relating to means and variances*

ISO 5813, *Water quality — Determination of dissolved oxygen — Iodometric method*

ISO 9862, *Geosynthetics — Sampling and preparation of test specimens*

ISO 10320, *Geosynthetics — Identification on site*

3 Terms and definitions

For the purposes of this document, the following terms and definitions apply.

ISO and IEC maintain terminological databases for use in standardization at the following addresses:

- ISO Online browsing platform: available at <https://www.iso.org/obp>
- IEC Electropedia: available at <http://www.electropedia.org/>

3.1

velocity index

v-index

velocity corresponding to a head loss of 50 mm across a specimen, expressed to the nearest ± 1 mm/s

4 Test specimens

4.1 Handling

The sample shall not be folded and shall be handled as infrequently as possible to avoid disturbance to its structure. The sample shall be kept in a flat position without any load.

4.2 Selection

Test specimens shall be taken from the sample in accordance with ISO 9862.

4.3 Number and dimensions

Five test specimens shall be cut from the sample, each of suitable dimensions for the water permeability apparatus to be used.

If it is necessary to determine the results to within a given confidence interval of the mean, the number of test specimens shall be determined in accordance with ISO 2854.

4.4 Specimen conditions

The specimens shall be clean, free from surface deposits and without visible damage or folding marks.

5 Constant head method

5.1 Principle

A single, unloaded layer of geotextile or geotextile-related product is subjected to a unidirectional flow of water normal to the plane under a range of constant heads.

5.2 Apparatus

5.2.1 Apparatus in which it is possible to observe the presence of air bubbles on the surface of the specimen, with an internal diameter of minimum 50 mm, conforming to the following requirements.

- a) The apparatus shall be capable of applying a maximum head loss of at least 70 mm and maintaining a constant head for the duration of each test with water on both sides of the specimen.

NOTE Some examples of apparatus are shown in [Figure 1](#).

- b) The mean internal diameter of the apparatus shall be known to an accuracy of at least 0,1 mm. The exposed diameter of the specimen shall be the same as the internal diameter of the apparatus. The diameter of the apparatus shall remain identical on both sides of the specimen over a length of at least twice its internal diameter [see [Figures 1 a\)](#) and [1 b\)](#)]. Abrupt changes in diameter shall be avoided.

Alternatively [see [Figure 1 c\)](#)], the outflow may discharge into a reservoir with a diameter of at least four times the exposed diameter of the specimen. In this case, the distance from the geotextile to the base of the reservoir shall be at least 1,5 times the exposed diameter of the specimen.

If the product shows an obvious pattern, this pattern shall be included at least three times along any diameter of the specimen.

- c) Where necessary, to avoid any visible deformation, a grid of 1 mm diameter wire and a mesh size of (10 ± 1) mm shall be placed downstream of the specimen to support it during the test.
- d) The head loss measured at any velocity when a test is performed without the test specimen, but including any specimen-supporting grid, shall be less than 1 mm.

5.2.2 Water supply, of the following quality and condition.

- a) The water shall be at a temperature of between 18 °C and 22 °C.

As the temperature correction (see [Annex A](#)) relates only to laminar flow, it is advisable to work at temperatures as close as possible to 20 °C to minimize inaccuracies associated with inappropriate correction factors, should the flow be non-laminar.

- b) Water shall not be fed into the apparatus directly from a main supply due to problems caused by the release of air bubbles, which can be entrapped in the structure of the specimen. The water

should preferably be de-aired or fed from a stilling tank. The water should not be continuously recycled.

- c) The oxygen content shall not exceed 10 mg/kg. The oxygen content shall be measured at the point at which the water enters the apparatus.
- d) The water shall be filtered if suspended solids are visible to the naked eye or if solids accumulate on or in the specimen, thus reducing the flow with time.

5.2.3 Dissolved-oxygen meter, or apparatus in accordance with ISO 5813.

5.2.4 Stopwatch, with an accuracy of 0,2 s.

5.2.5 Thermometer, with an accuracy of 0,5 °C.

5.2.6 Measuring vessel, of appropriate size for determining the volume of water to an accuracy of 1 % of the capacity of the vessel.

When the water flow is determined by volume, use a measuring vessel for determining volume to an accuracy of 1 %. When direct measurement of water flow velocity is made by gauge, the flow velocity shall be measured to an accuracy of 5 %. When determining the water volume by mass, it shall be determined to an accuracy of 1 %.

5.2.7 Measurement device for determining the applied head, to an accuracy of 3 %.

5.3 Procedure

5.3.1 Place the specimens under water containing 0,1 % volume (1 ml/l) non-ionic surfactant at laboratory temperature, gently stir to remove air bubbles and leave to saturate for at least 12 h.

5.3.2 Place a specimen in the apparatus and ensure that all joints are watertight.

5.3.3 Fill the apparatus with water until there is a 50 mm water head difference across the specimen. Shut off the water supply and, if the water heads do not equalize on each side of the specimen within 5 min, investigate the likelihood of any trapped air within the apparatus and repeat the procedure. If the water heads cannot be equalized within 5 min, this shall be noted in the test report.

NOTE If the full permeability characteristics of the geotextile or geotextile-related product have previously been established, then for control purposes it can be sufficient to determine the velocity index at a head loss of 50 mm only.

5.3.4 Adjust the flow to attain a head loss of (70 ± 5) mm and record this value to the nearest 1 mm. When the head has been steady for a minimum of 30 s, collect the water passing through the system in the measuring vessel over a fixed period of time and record the volume of water collected to the nearest 10 cm³ and the time to the nearest 1 s. The volume of water collected should be a minimum of 1 000 cm³ and the collection time should be a minimum of 30 s.

5.3.5 When the water flow is determined by volume, the volume of the measuring vessel shall not exceed twice the volume of the collected water.

5.3.6 If a flow velocity gauge is used, then a maximum velocity giving a head loss of about 70 mm should be set. The real velocity shall be taken as the average of three consecutive readings with a minimum time interval between readings of 15 s.

5.3.7 Repeat 5.3.4 for four lower head losses of approximately 0,8; 0,6; 0,4 and 0,2 times the maximum head loss, starting with the highest velocity and ending with the lowest.

5.3.8 The same principle applies to the velocity when using a flow velocity gauge.

5.3.9 Record the water temperature to the nearest 0,5 °C.

5.3.10 Repeat 5.3.2 to 5.3.9 with each of the remaining specimens.

5.4 Calculation and expression of results

5.4.1 Calculate the flow velocity at 20 °C, v_{20} , in metres per second, using [Formula \(1\)](#):

$$v_{20} = \frac{VR_T}{At} \quad (1)$$

where

V is the water volume measured, in cubic metres (m³);

R_T is the correction factor for water temperature T , in degrees Celsius, to a water temperature of 20 °C (see [Annex A](#));

A is the exposed specimen area, in square metres (m²);

t is the time measured to achieve the volume (V), in seconds (s).

Where the flow velocity, v_T , has been measured directly, a temperature correction is necessary according to [Formula \(2\)](#):

$$v_{20} = v_T R_T \quad (2)$$

NOTE The flow velocity, v_{20} , expressed in millimetres per second, equals the discharge, q , expressed in litres per square metre second.

5.4.2 For each of the five specimens, calculate the flow velocity, v_{20} , for each head loss, H .

5.4.3 Plot the head loss, H , against velocity, v_{20} , and select the best-fit curve through the origin for each specimen (see [Figure B.1](#)) in accordance with [Annex B](#), either by mathematical or graphical means. Present the five specimen curves on one graph.

NOTE If the full permeability characteristics of the geotextile or geotextile-related product have previously been established, then for control purposes it can be sufficient to determine the velocity index at a head loss of 50 mm only.

5.4.4 Produce a flow velocity value at the head loss of 50 mm, either by calculation or by graphical interpretation.

6 Falling head method

6.1 Principle

A single unloaded layer of geotextile or geotextile-related product is subjected to a unidirectional flow of water normal to the plane under a falling head.

6.2 Apparatus

6.2.1 Water-permeability apparatus, with the possibility of seeing the specimen from beneath, via a transparent tube or window, consisting of two interconnected cylinders of the same diameter of minimum 50 mm, complying with the following requirements.

- a) The apparatus shall be capable of achieving water heads of at least 250 mm for appropriate calculations.

To achieve a water head of at least 250 mm, it should start with a higher water level because the water head values recorded during the opening time of the valve cannot be used for calculation.

- b) The mean internal diameter of the cylinder of apparatus shall be known to an accuracy of at least 0,1 mm. The exposed diameter of the specimen shall be the same as the internal diameter of the apparatus. The diameter of the apparatus on both sides of the specimen shall remain identical over a length of at least twice its internal diameter. Within the range of changing water levels, the diameter shall be constant. Abrupt changes in diameter should be avoided.

If the product shows an obvious pattern, this pattern shall be included at least three times, along any diameter of the specimen.

- c) Where necessary, to avoid any visible deformation, a grid of 1 mm diameter wire and a mesh size of (10 ± 1) mm shall be placed downstream of the specimen to support it during the test.
- d) The head loss measured at any velocity when a test is performed without the test specimen, but including any specimen-supporting grid, shall be less than 1 mm.

NOTE Some examples of apparatus are shown in [Figure 2](#).

- e) The connecting tube between the two cylinders shall have a minimum diameter of 40 % of the diameter of the cylinders. It shall be flexible if the weighing cell method is used.

6.2.2 Water supply, of the following quality and condition.

- a) The water shall be at a temperature between 18 °C and 22 °C.

As the temperature correction (see [Annex A](#)) relates only to laminar flow, it is advisable to work at temperatures as close as possible to 20 °C to minimize inaccuracies associated with inappropriate correction factors, should the flow be non-laminar.

- b) Water shall not be fed into the apparatus directly from a main supply due to problems caused by the release of air bubbles which can lodge in the test specimen. The water should preferably be de-aired or fed from a stilling tank. The water in the apparatus should be replaced daily.
- c) The oxygen content shall not exceed 10 mg/kg. The oxygen content shall be measured at the point at which the water enters the apparatus.
- d) The water shall be filtered if suspended solids are visible to the naked eye or if solids accumulate on or in the specimen thus reducing the flow with time.

6.2.3 Dissolved-oxygen meter, or apparatus in accordance with ISO 5813.

6.2.4 Measuring device for determining the changing water head, with an accuracy of 3 %.

NOTE Possible means are:

- a) measuring the change in column mass (to ± 1 g);
- b) measuring the change in water pressure (to ± 1 Pa); and

- c) measuring the change in water level by an optical method (reading of water level using digitalized video equipment) or by an ultrasonic method.

Continuous recording of the data by an analogue writer or computer, from the beginning to the end of the test, is recommended (see [Figure 3](#)).

6.2.5 Thermometer, with an accuracy of 0,5 °C.

6.3 Procedure

6.3.1 Place the specimens under water containing 0,1% volume non-ionic surfactant at laboratory temperature, gently stir to remove air bubbles and leave to saturate for at least 12 h.

6.3.2 Place a specimen in the apparatus and ensure that all joints are watertight.

6.3.3 Fill the apparatus with water until there is a 50 mm water head difference across the specimen. Shut off the water supply and, if the water heads do not equalize on each side of the specimen within 5 min, investigate the likelihood of any trapped air within the apparatus and repeat the procedure. If the water heads cannot be equalized within 5 min, this shall be noted in the test report.

6.3.4 Close the valve. Fill the specimen cylinder of the apparatus to a height such that a useful head difference of at least 250 mm after complete opening of the valve is achieved [see the second paragraph of [6.2.1 a](#))].

6.3.5 Record the water temperature to the nearest 0,5 °C.

6.3.6 Switch on all instruments required for the method used (see [6.2.4](#)) and open the valve.

6.3.7 The test ends when head loss and flow velocity reach zero.

NOTE For highly permeable specimens, it is possible for the water levels at $v = 0$ m/s to not equalize due to inertia effects (see [Figure 3](#)). In these cases, the water level corresponding to $v = 0$ m/s for the first time is taken as the reference level for calculating head losses.

6.3.8 Repeat [6.3.2](#) to [6.3.7](#) with each of the remaining specimens.

6.4 Calculation and expression of results

6.4.1 From a chosen water-level interval on the graph of the analogue writer (see [Figure 3](#)) or the computerized data, calculate the flow velocity, v_{20} at 20 °C, in metres per second, using [Formula \(3\)](#):

$$v_{20} = \frac{\Delta h}{t} R_T \quad (3)$$

where

Δh is the difference between the upper water level, h_u , and the lower water level, h_l , in meters, at time interval t ;

t is the time interval between h_u and h_l , in seconds;

R_T is the correction factor to a water temperature of 20 °C (see [Annex A](#));

and the head loss, H , in metres, which is given by [Formula \(4\)](#):

$$H = h_u + h_l - 2h_0 \quad (4)$$

where

h_0 is the height of the water level at $v = 0$ m/s (see NOTE in [6.3.7](#));

h_u and h_l are the upper and lower levels of the head range on which the calculation is based.

NOTE The flow velocity, v , expressed in millimetres per second, equals the discharge, q , expressed in litres per square metre second.

6.4.2 For each of the five specimens, calculate the flow velocity, v , for each water head loss, H , at a minimum of five points along each curve.

6.4.3 In calculating the falling head curve, it is recommended that time intervals be 1/5 to 1/10 of the total time to carry out the experiment.

6.4.4 Plot the head loss, H , against velocity, v , and select the best-fit curve through the origin for each specimen, in accordance with [Annex B](#), by either mathematical or graphical means. Present the five specimen curves on one graph (see [Figure B.1](#)).

6.4.5 The test shall be used to produce a flow velocity value at the head loss of 50 mm either by calculation or by graphical interpretation.

7 Test report

The test report shall include the following information:

- a) the number and year of publication of this document, i.e. ISO 11058:2019;
- b) the test laboratory and, if required, the test operator;
- c) a description of the product tested in accordance with ISO 10320;
- d) the exposed specimen area;
- e) only where the full permeability characteristics are being measured, a collective plot of the velocity, v , and head loss, H , for each specimen;
- f) the velocity index for a head loss of 50 mm (v -index) and, if required, specimen values, sample mean, specimen maximum and minimum (see [Annex C](#));
- g) the water temperature range;
- h) the water type (stilled, de-aerated, de-ionized, filtered) and dissolved oxygen values;
- i) the type of flow gauge, if used;
- j) any deviation from this document;
- k) any anomaly in the hydraulic behaviour of the product;

and, if required:

- l) details of apparatus used, including a diagram;
- m) the experimental data and calculations for each specimen can be tabulated. Examples are given in [Annex D](#).

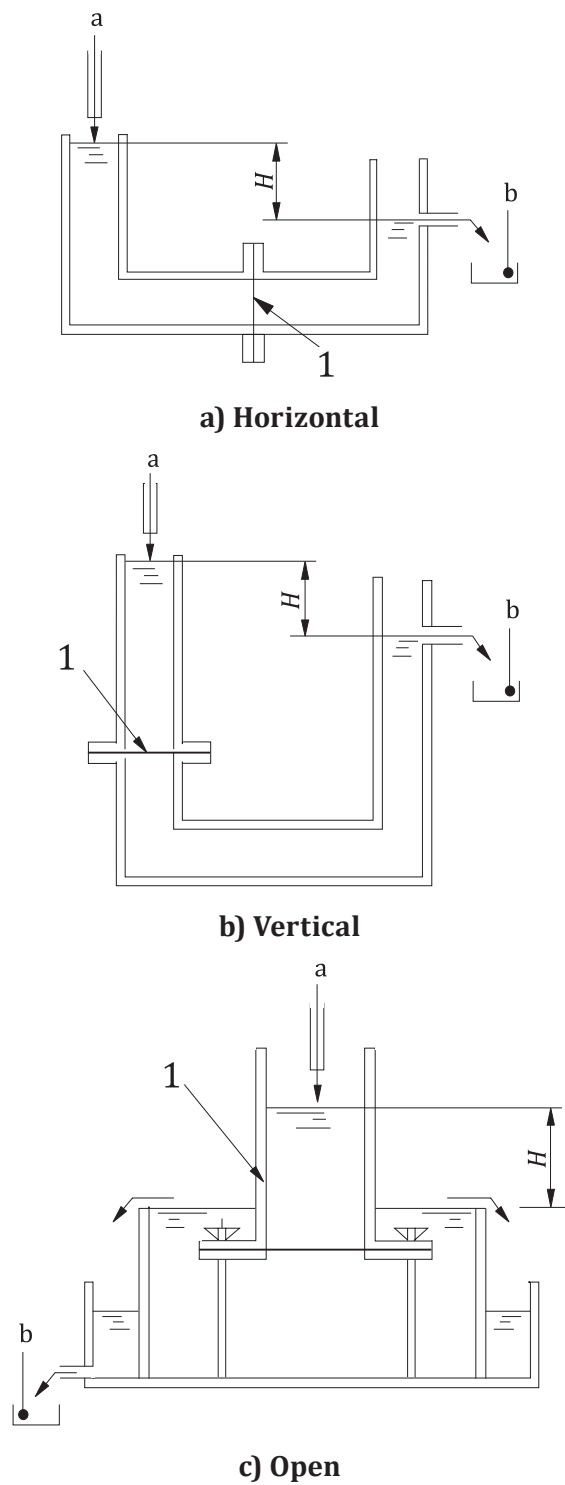

Key

- 1 specimen
- a Inflow.
- b Collected outflow.
- H head loss

Figure 1 — Examples of apparatus for the constant head method

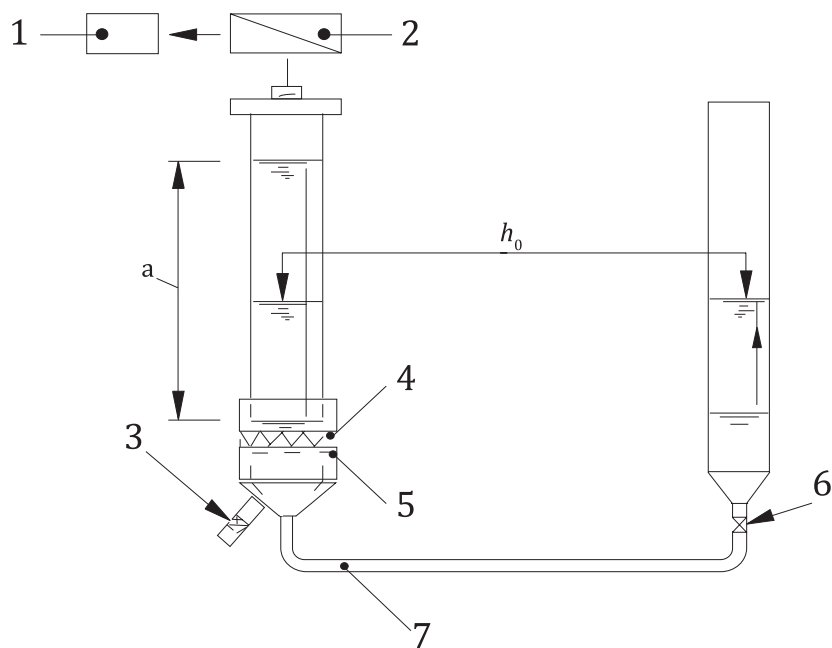

a) Weighing cell method

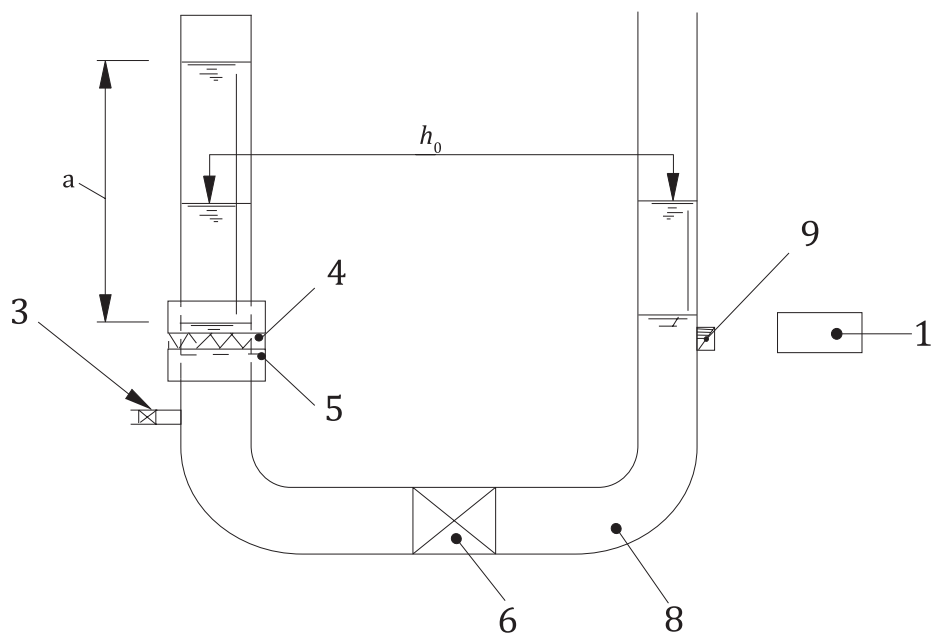

b) Pressure gauge method

Key

- | | | | |
|---|-------------------------------|---|---------------------------------------|
| 1 | analogue recorder or computer | 6 | main valve |
| 2 | weighing cell | 7 | flexible connecting tube |
| 3 | release valve | 8 | fixed connecting tube |
| 4 | specimen | 9 | pressure gauge |
| 5 | support grid | a | Water level difference at test start. |

Figure 2 — Examples of apparatus for the falling head method

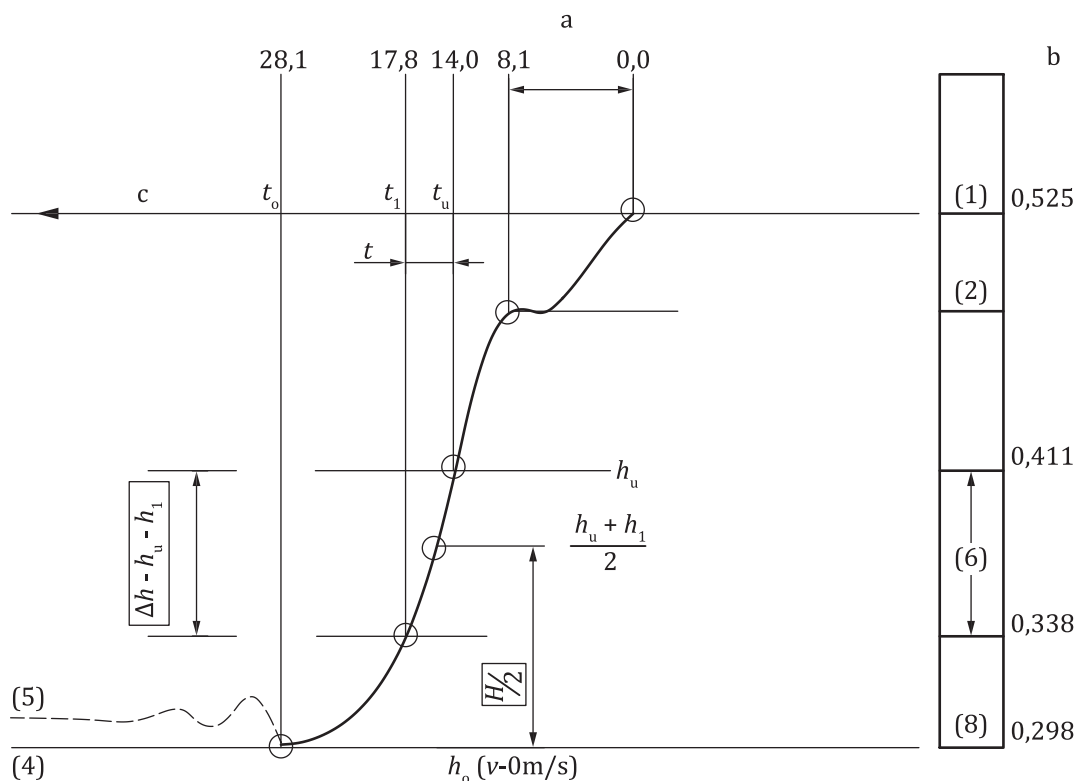

Key

- a Time to completely open the valve.
- b Water level height, in metres.
- c Time, t , in seconds.

Explanations	Remarks
(1) Water level at test start	(1) - (2) range inappropriate for calculation (2) - (8) range appropriate for calculation
(2) Water level after complete opening of the valve	
(8) Lowest water level (reference level for calculation)	
(4) Course of water level alteration (low permeable geotextile)	See Note in 6.3.7 .
(5) Course of water level alteration (high permeable geotextile)	
(6) Example for calculation	See Table D.2 .

Figure 3 — Example of a falling water level as recorded by an analogue writer

Annex A (informative)

Determination of the correction factor, R_T , to a water temperature of 20 °C

$$R_T = \frac{\eta_T}{\eta_{20}} = \frac{1,762}{1 + 0,0337T + 0,00022T^2} \quad (\text{dimensionless})$$

with

$$\eta_T = \frac{1,78}{1 + 0,0337T + 0,00022T^2} \quad (\text{mPa}\cdot\text{s})$$

where

η_T is the dynamic viscosity at T °C, in millipascal seconds;

T is the water temperature, in degrees Celsius;

η_{20} is the dynamic viscosity at 20 °C, in millipascal seconds;

R_T is the correction factor to a water temperature of 20 °C.

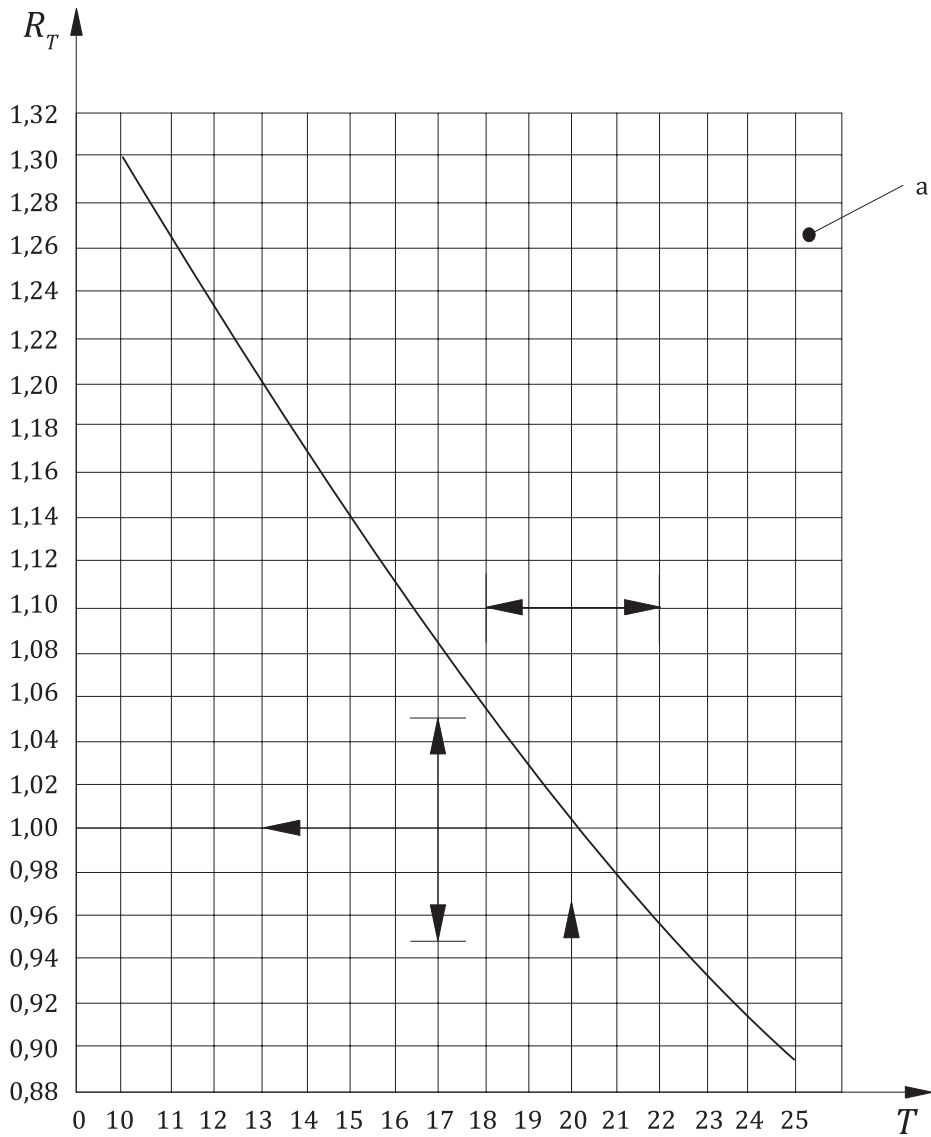

Key

T test temperature, in degrees Celsius

R_T correction factor

^a Temperature range from 18 °C to 22 °C [see 5.2.2 a)].

Figure A.1 — Graphical presentation of the correction factor, R_T

Annex B (normative)

Relationship between head loss and flow velocity

The general relationship between head loss, H , and flow velocity, v , can be expressed by the quadratic function:

$$H = av + bv^2$$

Using the experimental data v_{20} and H in [Table B.1](#), the best-fit quadratic curve passing through the origin can be determined through the paired terms v and H , as illustrated in [Figure B.1](#).

This graph allows the determination of the velocity at a head loss of 50 mm.

Table B.1 — Experimental data of velocity, v , and head loss, H , after temperature correction

v_{20} mm/s	H mm
19,7	20,0
28,3	30,1
35,3	40,0
41,9	50,0
46,8	60,0

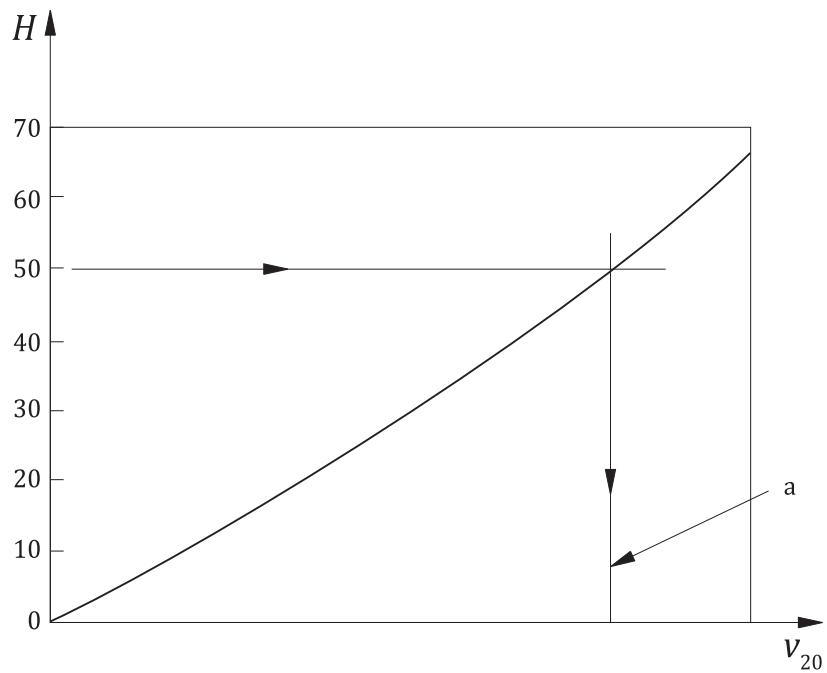

Key

v_{20} velocity, in millimetres per second

H head loss, in millimetres

a Velocity index, v -index.

Figure B.1 — Fitted quadratic regression curve v_{20}, H

Annex C (informative)

Individual velocity index values for a head loss of 50 mm

Product designation: _____

Date: _____

Sample designation: _____

Table C.1 — Velocity index

Specimen	Velocity index (<i>v</i> -index) at a head loss of 50 mm m/s
1	
2	
3	
4	
5	
Mean	
Maximum	
Minimum	

Annex D (informative)

Experimental data and calculations

Table D.1 — Experimental data and calculations for a geotextile or geotextile-related product specimen (constant head method)

Specimen: _____ Date: _____
 Exposed area of the tested specimen: _____ m²
 Product designation: _____
 Laboratory temperature: _____ °C
 Sample designation: _____

Head loss <i>H</i> m	Water volume <i>V</i> m ³	Time <i>t</i> s	Water temperature <i>T</i> °C	Correction factor <i>R_T</i>	Velocity <i>v</i> ₂₀ m/s	Gauge <i>v_T</i> m/s

Table D.2 — Experimental data and calculations for a geotextile or geotextile-related product specimen (falling head method)

Specimen: _____ Date: _____
 Exposed area of the tested specimen: _____ m²
 Product designation: _____
 Laboratory temperature: _____ °C
 Sample designation: _____

Chosen water level interval					Water level at $v = 0$	Water temperature T	Correction factor R_T	$\Delta h =$ (2) - (4)	$t =$ (5) - (3)	$v_{20} =$ (9)(8)/ (10)	$H =$ (2) + (4) - 2(6)
No.	Upper limit		Lower limit								
(1)	h_u m (2)	t_u s (3)	h_l m (4)	t_l s (5)	h_o m (6)	T °C (7)	— (8)	m (9)	s (10)	m/s (11)	m (12)
1											
2 ^a	0,411	14,0	0,338	17,8	0,298	18,0	1,051	0,073	3,8	0,020	0,153
3											
4											
5											

^a For an example, see [Figure 3](#).

[*\(Continued from second cover\)*](#)

In reporting the result of a test or analysis made in accordance with this standard, if the final value, observed or calculated, is to be rounded off, it shall be done in accordance with IS 2 : 2022 'Rules for rounding off numerical values (*second revision*)'.

Bureau of Indian Standards

BIS is a statutory institution established under the *Bureau of Indian Standards Act, 2016* to promote harmonious development of the activities of standardization, marking and quality certification of goods and attending to connected matters in the country.

Copyright

BIS has the copyright of all its publications. No part of these publications may be reproduced in any form without the prior permission in writing of BIS. This does not preclude the free use, in the course of implementing the standard, of necessary details, such as symbols and sizes, type or grade designations. Enquiries relating to copyright be addressed to the Head (Publication & Sales), BIS.

Review of Indian Standards

Amendments are issued to standards as the need arises on the basis of comments. Standards are also reviewed periodically; a standard along with amendments is reaffirmed when such review indicates that no changes are needed; if the review indicates that changes are needed, it is taken up for revision. Users of Indian Standards should ascertain that they are in possession of the latest amendments or edition by referring to the website-www.bis.gov.in or www.standardsbis.in.

This Indian Standard has been developed from Doc No.: TXD 30 (25141).

Amendments Issued Since Publication

Amend No.	Date of Issue	Text Affected

BUREAU OF INDIAN STANDARDS

Headquarters:

Manak Bhavan, 9 Bahadur Shah Zafar Marg, New Delhi 110002

Telephones: 2323 0131, 2323 3375, 2323 9402

Website: www.bis.gov.in

Regional Offices:

	Telephones
Central : 601/A, Konnectus Tower -1, 6 th Floor, DMRC Building, Bhavbhuti Marg, New Delhi 110002	{ 2323 7617
Eastern : 8 th Floor, Plot No 7/7 & 7/8, CP Block, Sector V, Salt Lake, Kolkata, West Bengal 700091	{ 2367 0012 2320 9474
Northern : Plot No. 4-A, Sector 27-B, Madhya Marg, Chandigarh 160019	{ 265 9930
Southern : C.I.T. Campus, IV Cross Road, Taramani, Chennai 600113	{ 2254 1442 2254 1216
Western : 5 th Floor/MTNL CETTM, Technology Street, Hiranandani Gardens, Powai Mumbai 400076	{ 25700030 25702715

Branches : AHMEDABAD, BENGALURU, BHOPAL, BHUBANESHWAR, CHANDIGARH, CHENNAI, COIMBATORE, DEHRADUN, DELHI, FARIDABAD, GHAZIABAD, GUWAHATI, HARYANA (CHANDIGARH), HUBLI, HYDERABAD, JAIPUR, JAMMU, JAMSHEDPUR, KOCHI, KOLKATA, LUCKNOW, MADURAI, MUMBAI, NAGPUR, NOIDA, PARWANOO, PATNA, PUNE, RAIPUR, RAJKOT, SURAT, VIJAYAWADA.