

वस्त्रादि — कृत्रिम रेशा धागा — टेक्श्चर्ड
धागों के क्रिम्प गुणधर्म की परीक्षण
पद्धतियाँ

(ISO 5688 : 2024, संशोधित)

Textiles — Synthetic Filament
Yarns — Test Methods for Crimp
Properties of Textured Yarns

(ISO 5688 : 2024, MOD)

ICS 59.080.20

© BIS 2024

© ISO 2024



भारतीय मानक ब्यूरो

BUREAU OF INDIAN STANDARDS

मानक भवन, 9 बहादुर शाह ज़फर मार्ग, नई दिल्ली - 110002

MANAK BHAVAN, 9 BAHADUR SHAH ZAFAR MARG

NEW DELHI - 110002

www.bis.gov.in

www.standardsbis.in

NATIONAL FOREWORD

This Indian Standard which is modified adoption of ISO 5688 : 2024 'Textiles — Synthetic filament yarns — Test methods for crimp properties of textured yarns' issued by the International Organization for Standardization (ISO) was adopted by the Bureau of Indian Standards on recommendation of the Physical Methods of Test Sectional Committee and approval of the Textiles Division Council.

The text of ISO standard has been approved as suitable for publication as Indian Standard without deviations. Certain conventions are however, not identical to those used in Indian Standards. Attention is particularly drawn to the following:

- a) Wherever the words 'International Standard' appears referring to this standard, they should be read as 'Indian Standard'; and
- b) Comma (,) has been used as a decimal marker while in Indian Standards, the current practice is to use a point (.) as the decimal marker.

In this adopted standard, reference appears to the following International Standards for which Indian Standards also exist. The corresponding Indian Standards which are to be substituted in their respective places are listed below along with its degree of equivalence for the editions indicated.

<i>International Standard</i>	<i>Corresponding Indian Standard</i>	<i>Degree of Equivalence</i>
ISO 139 Textiles — Standard atmospheres for conditioning and testing	IS 6359 : 2023 Method for conditioning of textiles (<i>first revision</i>)	Technically Equivalent
ISO 3534-1 Statistics — Vocabulary and symbols — Part 1: General statistical terms and terms used in probability	IS 7920 (Part 1) : 2012 Statistical — Vocabulary and symbols: Part 1 General statistical terms and terms used in probability (<i>third revision</i>)	Modified
ISO 3696 Water for analytical laboratory use — Specification and test methods	IS 1070 : 2023 Reagent grade water — Specification (<i>fourth revision</i>)	Technically Equivalent

The Committee has reviewed the provisions of the following International Standard referred in this adopted standard and has decided that it is acceptable for use in conjunction with this standard:

<i>International Standard</i>	<i>Title</i>
ISO 10132	Textiles — Textured filament yarn — Definitions

In reporting the result of a test or analysis made in accordance with this standard, if the final value, observed or calculated, is to be rounded off, it shall be done in accordance with IS 2 : 2022 'Rules for rounding off numerical values (*second revision*)'.

Contents

Page

1	Scope	1
2	Normative references	1
3	Terms and definitions	1
4	Principle	1
5	Reagents	2
6	Apparatus	2
7	Sampling	4
8	Standard atmosphere for conditioning and testing	4
9	Preparation of test specimen	4
	9.1 Tension for reeling.....	4
	9.2 Turns of reel.....	5
	9.3 Reeling.....	5
	9.4 Number of tests.....	5
	9.5 Conditioning.....	6
10	Test procedure	6
	10.1 Crimp development.....	6
	10.1.1 Method A — Hot air method.....	6
	10.1.2 Method B — Hot water method.....	6
	10.2 Measuring lengths.....	7
11	Calculation and expression of results	8
	11.1 Crimp contraction.....	8
	11.2 Crimp modulus.....	8
	11.3 Crimp stability.....	9
	11.4 Test results.....	9
12	Precision	9
13	Test report	9
	Annex A (informative) Precision experiments	10
	Bibliography	12

*Indian Standard***TEXTILES — SYNTHETIC FILAMENT YARNS — TEST METHODS
FOR CRIMP PROPERTIES OF TEXTURED YARNS****(ISO 5688 : 2024, MOD)****1 Scope**

This document specifies a test method for crimp properties of synthetic textured filament yarns.

Two treatment methods for crimp development are provided:

- Method A: Hot air method, and
- Method B: Hot water method.

2 Normative references

The following documents are referred to in the text in such a way that some or all of their content constitutes requirements of this document. For dated references, only the edition cited applies. For undated references, the latest edition of the referenced document (including any amendments) applies.

ISO 139, *Textiles — Standard atmospheres for conditioning and testing*

ISO 3534-1, *Statistics — Vocabulary and symbols — Part 1: General statistical terms and terms used in probability*

ISO 3696, *Water for analytical laboratory use — Specification and test methods*

ISO 10132, *Textiles — Textured filament yarn — Definitions*

3 Terms and definitions

For the purposes of this document, the terms and definitions given in ISO 10132 and the following apply.

ISO and IEC maintain terminological databases for use in standardization at the following addresses:

- ISO Online browsing platform: available at <https://www.iso.org/obp/ui>
- IEC Electropedia: available at <https://www.electropedia.org/>

3.1**crimp modulus**

ratio of difference between the straightened length (L_g) and the length (L_f) of the yarn under a low tension, to the straightened length (L_g), as to characterize the elongation behaviour of a textured yarn in the range of crimp elasticity

Note 1 to entry: It is expressed as a percentage.

4 Principle

Textured filament yarns have a certain crimp trend. By certain methods, the crimp is gradually revealed. The variations in lengths, measured in crimped state and in straightened state, are used to calculate crimp contraction and other parameters, as to characterise crimp properties of textured filament yarns. The test specimen is in the form of a skein or a simple loop.

5 Reagents

5.1 Aqueous solution

If crimp development Method B (see [10.1.2](#)) is selected, distilled water or grade 3 water in accordance with ISO 3696 shall be used, to which a non-ionic surfactant to a concentration of 0,1 g/l has been added. Different concentrations of non-ionic surfactant may be allowed on agreement between the interested parties.

6 Apparatus

6.1 Skein winding reel

- a) Reel, with a circumference of $(1\ 000 \pm 2,5)$ mm, driven either automatically or manually;
- b) Traversing mechanism to avert overlapping while a number of skeins being wound at the same time;
- c) Tensioning device, maintaining the specified tension to an accuracy of $\pm 10\ %$;
- d) Device to count the turns of the reel, preferably warning or stopping winding automatically, just prior to the specified number of reel revolutions;
- e) Suitable mechanism to reduce the reel circumference for easy removal of the skein.

6.2 Test specimen holder

- a) Frame, with a row of hooks separately on the upper and lower ends, for hanging test specimens vertically (see [Figure 1](#)). In order to prevent slipping inside the knotted ends, especially for coarse yarn test specimens, the upper hooks possibly to be replaced by a clamping mechanism, while every test specimen consisting of a simple loop in "U" shape, as to eliminate the need for knot;
- b) Upper hooks or clamps fixed on the frame;
- c) Lower hooks subjected to applied tension, moving without friction along the wires on both sides to avoid test specimens twisting;
- d) Over 600 mm in height, with test specimens adequately spaced apart so as not to touch each other.

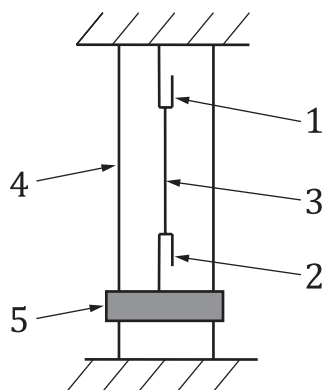
**Key**

- 1 upper hook or clamp
- 2 lower hook
- 3 test specimen
- 4 wire
- 5 tension load

Figure 1 — Schematic diagram of test specimen holder

6.3 Device for length measurement

- a) Device to measure the lengths of test specimens in vertical position;
- b) Allowing to apply different tensions, either manually or automatically;
- c) Equipped with a suitable length measuring system, to an accuracy of $\pm 0,1$ mm.

6.4 Ventilated oven

- a) Equipped with adequate ventilation to reach the specified temperature within the range from 30 °C to 130 °C and to maintain a temperature variation within ± 2 °C in the immediate vicinity of the test specimens;
- b) Interior with a height of at least 600 mm to accommodate the test specimen holder (6.2, Figure 1) in an upright position, and with sufficient volume in which the test specimen holder (6.2, Figure 1) does not occupy more than 80 % of the volume;
- c) Capable to hold test specimens including tension loads at lower ends in vertical position, without contacting the interior sides of the oven.

6.5 Hot water container

- a) Device equipped with a heater and temperature controller, capable to be set at 100 °C and to maintain the temperature variation within ± 3 °C in the immediate vicinity of the test specimens;
- b) Interior with a height of at least 600 mm high to accommodate the test specimen holder (6.2, Figure 1) in an upright position and assure the test specimen holder (6.2, Figure 1) completely immersed by hot water;
- c) If necessary, the container may be equipped with a mechanism to fix the test specimen holder.

6.6 Device for tension application

- a) Device with loading mechanism, to apply different tensions at the bottoms of test specimens, either manually or automatically;
- b) During application, avoiding the tension overshooting the target value more than 10 %.

7 Sampling

Sampling shall be performed as follows:

- a) bulk laboratory sample shall be taken on request;
- b) the number of lot sample and laboratory sample are listed in [Table 1](#).

Packages that have been dampened, bruised, or opened during the transportation shall not be sampled.

Elapsed time between processing and testing has a significant effect on the results of crimp properties testing (caused by stress decay), especially during the first 72 h. Therefore, laboratory sample shall be chosen from the packages of same elapsed time, and not earlier than 5 days after processing. However, after an elapsed time of 7 days, the effect of stress decay may be neglected.

Table 1 — Number of lot sample and laboratory sample

Number of containers in the consignment	Number of containers in the first selection	Number of containers taken for consignment sample	Number of packages sampled from each container	Number of packages chosen for laboratory sample
10 or less	all	all	see below ^a	20 approx.
11 to 20	10	10	2	20
21 to 40	20	10	2	20
more than 40	40	20	1	20

^a Take an equal number of packages from each container. The number of packages for laboratory sample should be at least 20. If the consignment includes less than 20 packages, sample all of them.

8 Standard atmosphere for conditioning and testing

The standard atmosphere for conditioning and testing shall be in accordance with ISO 139.

9 Preparation of test specimen

9.1 Tension for reeling

Calculate the tension for reeling according to [Formula \(1\)](#).

$$F = P \times T \quad (1)$$

where

- F is the tension, expressed in cN;
- P is the tension per unit linear density, expressed in cN/dtex; for textured yarns, it is $(0,20 \pm 0,02)$ cN/dtex;
- T is the nominal linear density of the yarns, expressed in dtex.

For those filament yarns which the above tension is not applicable, the tension for reeling may be determined on agreement between the interested parties and shall be stated in the test report.

9.2 Turns of reel

Calculate the number of turns according to [Formula \(2\)](#).

$$n = \frac{T_t}{2 \times T} \quad (2)$$

where

- n is the number of turns, rounded to nearest whole number;
- T_t is the set linear density of the skein, expressed in dtex;
- T is the nominal linear density of the yarns, expressed in dtex.

The recommended set linear density of skein is listed in [Table 2](#).

Table 2 — Recommended set linear density of skein

Nominal linear density of the test specimen	Set linear density of the skein
≤200 dtex	2 500 dtex
(200 dtex, 400 dtex]	5 000 dtex
>400 dtex	10 000 dtex

For those filament yarns which above recommended set linear densities are not applicable, the set linear density of skein shall be determined on agreement between the interested parties and stated in the test report.

9.3 Reeling

Discard the yarn from the outer layers of the package in the laboratory samples. If test specimens are sampled from the same package, at least 5 m of yarn should be discarded between each test specimen.

Lead the yarn through the tension device and fix the end on the clip of the reel. Use a uniform tension for reeling as specific in [9.1](#) and reel the specific turns as [9.2](#), evenly and smoothly.

Cut the yarn close to the clip and tie two yarn ends together, without stretch. Remove the skein from the reel carefully and avoid tangling.

Hang the test specimens on the test specimen holder ([6.2](#), [Figure 1](#)) with a tension in per unit set linear density (see [Table 2](#)) of $(0,001\ 0 \pm 0,000\ 1)$ cN/dtex at the bottom of each test specimen and maintain this tension throughout the whole test. When suspending the skeins on the test specimen holder ([6.2](#), [Figure 1](#)), the knots are placed at the suspension hooks.

Test specimens consisting of a simple loop in "U" shape do not require reeling. Those test specimens are inserted into the specimen holder such, that the yarn length from clamping point around the lower hook back to the clamping points equals $(1\ 000 \pm 2,5)$ mm.

9.4 Number of tests

9.4.1 For bulk laboratory sample, the minimum number of test specimens shall be 2 from each package and the total number of tests shall not be less than 30 for one lot.

9.4.2 For lot laboratory sample, each package is tested twice, and the total number of tests shall not be less than 30. In arbitration test, 3 test specimens are prepared for each package, and the total number of tests shall not be less than 60.

9.5 Conditioning

9.5.1 Prior to testing, conditioning is not necessary for test specimens.

9.5.2 In arbitration test, test specimens shall be vertically suspended in the standard atmosphere (see [Clause 8](#)) to reach moisture equilibrium.

Throughout the sampling, preparation of test specimen and conditioning procedures, particular care shall be taken that any stress applied to the test specimens in the course of handling does not exceed the tensile force applied during reeling.

10 Test procedure

10.1 Crimp development

10.1.1 Method A — Hot air method

10.1.1.1 Select the appropriate condition of crimp development according to type of the textured yarns. Some recommended conditions are listed in [Table 3](#).

Table 3 — Recommended condition of crimp development

Type of the textured yarns	Crimp development temperature (°C)	Treatment time (min)
Polyester (including PET, PBT, PTT)	120 ± 2	10 ± 1
Polyamide	120 ± 2	10 ± 1
Polypropylene	60 ± 2	10 ± 1

For those filament yarns which the above recommended conditions are not applicable, the temperature and treatment time shall be determined on agreement between the interested parties and stated in the test report.

10.1.1.2 Preheat the oven ([6.4](#)) to the specified temperature according to [Table 3](#) and keep temperature steady.

10.1.1.3 Place the test specimen holder ([6.2](#), [Figure 1](#)) with the test specimens and tensioning weights into the oven ([6.4](#)) quickly. When the oven returns to the specified temperature, begin measuring treatment time as specified in [Table 3](#).

10.1.1.4 After treatment, carefully take out the holder with test specimens. Expose the test specimens vertically suspended in the standard atmosphere (see [Clause 8](#)) to reach moisture equilibrium.

The period of conditioning the test specimens after treatment may be reduced, e.g. to 30 min, provided that this is clearly stated in the test report. Only test results obtained with identical conditioning periods are comparable.

10.1.2 Method B — Hot water method

10.1.2.1 Fill the hot water container ([6.5](#)) with an aqueous solution ([5.1](#)). The quantity of solution shall be sufficient to assure the test specimen holder ([6.2](#), [Figure 1](#)) and test specimens to be completely immersed. Preheat the solution to 100 °C.

10.1.2.2 Place the test specimen holder (6.2, Figure 1) with the test specimens and tensioning weights into the hot water container (6.5) preheated to 100 °C. Maintain it vertically, immerse it completely in water and keep it there for (10 ± 1) min.

10.1.2.3 After treatment, take the test specimen holder (6.2, Figure 1) out carefully and let the water drip away for at least 10 min. To shorten the time required to remove the remaining humidity from the test specimens, careful removing of excessive water is permitted by means of blotting paper. Then place the specimen holder (6.2, Figure 1) into the oven (6.4) at a temperature of (40 ± 3) °C for at least 30 min. If the test specimens are not completely dry, extend the drying time accordingly. Afterwards, expose the test specimens vertically suspended in the standard atmosphere (see Clause 8) to reach moisture equilibrium.

The period of conditioning the test specimens after treatment may be reduced, e.g. to 30 min, provided that this is clearly stated in the test report. Only test results obtained with identical conditioning periods are comparable.

10.2 Measuring lengths

10.2.1 While maintaining a tension in per unit set linear density (Table 2) of $(0,001\ 0 \pm 0,000\ 1)$ cN/dtex at bottom of each test specimen, apply additional tensions according to the requirements specified in Table 4.

10.2.2 Under the specified tension, after the specified loading time, measure the length of each test specimen.

10.2.3 Change the tension in sequence described in Table 4, Figure 2 and measure the length in different conditions after the specified duration.

10.2.4 Follow the procedures successively, the required tension, duration and length code are listed in Table 4.

Table 4 — Required tension, duration and length code

Procedures	Tension per unit set linear density	Duration ^a	Length code
1	$(0,20 \pm 0,02)$ cN/dtex	10 s	L_g
2	$(0,001\ 0 \pm 0,000\ 1)$ cN/dtex	10 min	L_z
3 ^b	$(0,010 \pm 0,001)$ cN/dtex	10 s	L_f
4	Polyester (including PET, PBT, PTT) textured yarns	10 s	—
	Polypropylene textured yarns		
	Polyamide jet-bulked textured yarns		
	Polyamide draw-textured yarns		
5	$(0,001\ 0 \pm 0,000\ 1)$ cN/dtex	20 min ^c	L_b

^a Maintain the specified duration to an accuracy of $\pm 0,5$ s.

^b After application of the load of procedure 3, the load may return to $(0,001\ 0 \pm 0,000\ 1)$ cN/dtex before applying the load of procedure 4.

^c On agreement between the interested parties, a duration of 10 min is permitted before measuring L_b .

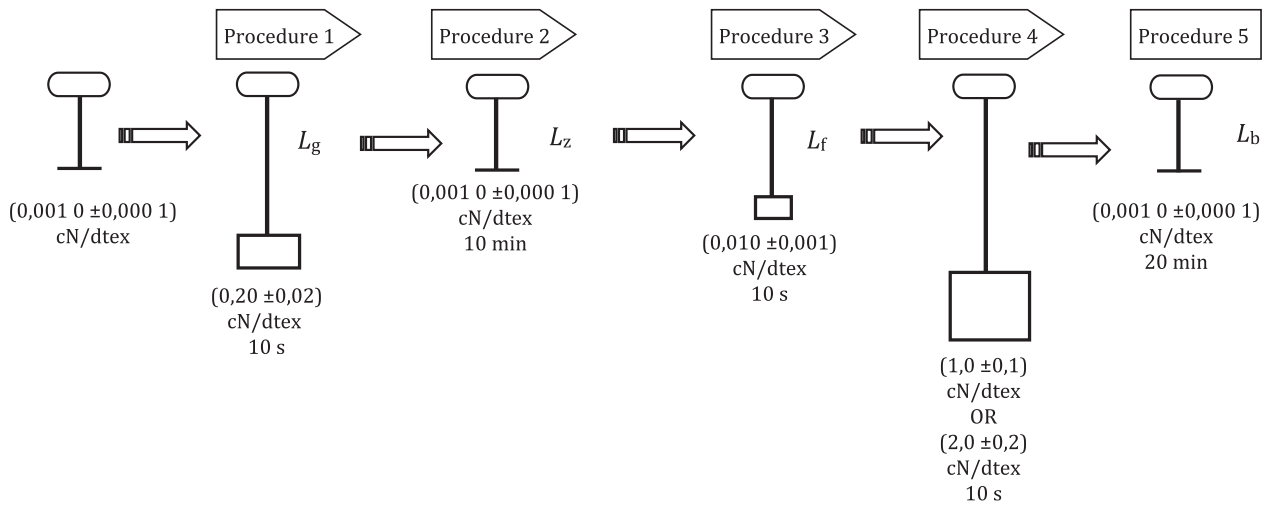

Figure 2 — Continuous changing tension and measuring length

10.2.5 On agreement between the interested parties, if only crimp contraction need to be measured, procedures 3, 4 and 5 may be omitted. In the same way, if only crimp contraction and crimp stability need to be measured, procedure 3 may be omitted.

11 Calculation and expression of results

11.1 Crimp contraction

Calculate the crimp contraction according to [Formula \(3\)](#).

$$C_C = \frac{L_g - L_z}{L_g} \times 100 \% \quad (3)$$

where

C_C is the crimp contraction;

L_g is the length of test specimen measured in procedure 1 of [Table 4](#), expressed in mm;

L_z is the length of test specimen measured in procedure 2 of [Table 4](#), expressed in mm.

11.2 Crimp modulus

Calculate the crimp modulus according to [Formula \(4\)](#).

$$C_M = \frac{L_g - L_f}{L_g} \times 100 \% \quad (4)$$

where

C_M is the crimp modulus;

L_g is the length of test specimen measured in procedure 1 of [Table 4](#), expressed in mm;

L_f is the length of test specimen measured in procedure 3 of [Table 4](#), expressed in mm.

11.3 Crimp stability

Calculate the crimp stability according to [Formula \(5\)](#).

$$C_S = \frac{L_g - L_b}{L_g - L_z} \times 100 \% \quad (5)$$

where

C_S is the crimp stability;

L_g is the length of test specimen measured in procedure 1 of [Table 4](#), expressed in mm;

L_b is the length of test specimen measured in procedure 5 of [Table 4](#), expressed in mm;

L_z is the length of test specimen measured in procedure 2 of [Table 4](#), expressed in mm.

11.4 Test results

Calculate arithmetic mean value, standard deviation and coefficient of variation (*CV*) for each parameter, in accordance with ISO 3534-1.

The test results shall be accurate to 0,1 %.

12 Precision

See [Annex A](#).

13 Test report

The test report shall include at least the following information:

- a) a reference to this document, i.e. ISO 5688:2024;
- b) all details necessary for the identification of the sample tested;
- c) nominal linear density of the sample, set linear density of test specimen (skein or single loop) and turns of reel;
- d) number of packages and number of test specimens per package;
- e) crimp development method (Method A or Method B) and conditions (including temperature and treatment time; type and concentration of surfactant in reagent for hot water method);
- f) conditioning before and after crimp development, the period of conditioning the test specimens after treatment, if reduced;
- g) test conditions (including tensions per unit set linear density and duration);
- h) test results for each package of laboratory sample as described in [Clause 11](#);
- i) any deviation, by agreement or otherwise, from the procedure specified;
- j) any unusual features observed;
- k) the date of the test.

Annex A (informative)

Precision experiments

A.1 Description

Ten laboratories participated in precision experiment, providing test results for two materials (three packages for each material), each package repeated five times. In other words, two different kinds of textured yarns were tested for 15 times, respectively. Results are analysed following ISO 5725-2.

A.2 Repeatability

Following the method specified in this document, one operator, using the same apparatus, tested identical test items within short intervals of time.

The absolute difference between two independent test results obtained under repeatability conditions shall not be greater than the repeatability limit (r) listed in [Table A.1](#), provided that the case greater than the repeatability limit (r) is not more than 5 %.

A.3 Reproducibility

Following the method specified in this document, different operators in different laboratories, using different apparatus, tested identical test items.

The absolute difference between two independent test results obtained under reproducibility conditions shall not be greater than the reproducibility limit (R) listed in [Table A.1](#), provided that the case greater than the reproducibility limit (R) is not more than 5 %.

Table A.1 — Precision of test results in two materials

Crimp development method	Textured yarns	Parameter	Mean value	Repeatability r	Reproducibility R
Method A Hot air method	1# Polyester/polyester bicomponent (PBT/ PET) [S/S type]	Crimp contraction (C_C)/%	37,5	1,0	2,3
		Crimp stability (C_S)/%	90,8	2,2	4,0
	2# Polyester/polyester bicomponent (PTT/ PET) [S/S type]	Crimp contraction (C_C)/%	40,9	1,7	3,2
		Crimp stability (C_S)/%	84,9	1,4	3,0
Method B Hot water method	1# Polyester/polyester bicomponent (PBT/ PET) [S/S type]	Crimp contraction (C_C)/%	41,8	2,7	5,7
		Crimp stability (C_S)/%	88,4	2,5	5,0
	2# Polyester/polyester bicomponent (PTT/ PET) [S/S type]	Crimp contraction (C_C)/%	44,4	1,8	4,5
		Crimp stability (C_S)/%	81,9	1,5	2,4

Bibliography

- [1] ISO 1144, *Textiles — Universal system for designating linear density (Tex System)*
- [2] ISO 2060, *Textiles — Yarn from packages — Determination of linear density (mass per unit length) by the skein method*
- [3] ISO 2076, *Textiles — Man-made fibres — Generic names*
- [4] ISO 2947, *Textiles — Integrated conversion table for replacing traditional yarn numbers by rounded values in the Tex System*
- [5] ISO 5725-1, *Accuracy (trueness and precision) of measurement methods and results — Part 1: General principles and definitions*
- [6] ISO 5725-2, *Accuracy (trueness and precision) of measurement methods and results — Part 2: Basic method for the determination of repeatability and reproducibility of a standard measurement method*
- [7] ISO 8160, *Textiles — Textured filament yarns — Vocabulary*
- [8] ASTM D4031-07, (Reapproved 2012), *Standard Test Method for Bulk Properties of Textured yarn*
- [9] BISFA-2007 *Internationally agreed methods for testing textured filament yarn*
- [10] DIN 53840-1:1983, *Testing of textiles; determination of parameters for the crimp of textured filament yarns — filament yarns with a linear density of up to 500 dtex*
- [11] DIN 53840-2:1983, *Testing of textiles; determination of parameters for the crimp of textured filament yarns — filament yarns with a linear density exceeding 500 dtex*
- [12] EN 14621:2005, *Textiles — Multifilament yarns — Methods of test for textured or non-textured filament yarns*
- [13] GB/T 6506-2017, *Textiles — Test method for crimp contraction properties of textured filament yarn*

Bureau of Indian Standards

BIS is a statutory institution established under the *Bureau of Indian Standards Act, 2016* to promote harmonious development of the activities of standardization, marking and quality certification of goods and attending to connected matters in the country.

Copyright

BIS has the copyright of all its publications. No part of these publications may be reproduced in any form without the prior permission in writing of BIS. This does not preclude the free use, in the course of implementing the standard, of necessary details, such as symbols and sizes, type or grade designations. Enquiries relating to copyright be addressed to the Head (Publication & Sales), BIS.

Review of Indian Standards

Amendments are issued to standards as the need arises on the basis of comments. Standards are also reviewed periodically; a standard along with amendments is reaffirmed when such review indicates that no changes are needed; if the review indicates that changes are needed, it is taken up for revision. Users of Indian Standards should ascertain that they are in possession of the latest amendments or edition by referring to the website-www.bis.gov.in or www.standardsbis.in.

This Indian Standard has been developed from Doc No.: MTD 03 (20809).

Amendments Issued Since Publication

Amend No.	Date of Issue	Text Affected

BUREAU OF INDIAN STANDARDS

Headquarters:

Manak Bhavan, 9 Bahadur Shah Zafar Marg, New Delhi 110002

Telephones: 2323 0131, 2323 3375, 2323 9402

Website: www.bis.gov.in

Regional Offices:

	Telephones
Central : 601/A, Konnectus Tower -1, 6 th Floor, DMRC Building, Bhavbhuti Marg, New Delhi 110002	{ 2323 7617
Eastern : 8 th Floor, Plot No 7/7 & 7/8, CP Block, Sector V, Salt Lake, Kolkata, West Bengal 700091	{ 2367 0012 2320 9474
Northern : Plot No. 4-A, Sector 27-B, Madhya Marg, Chandigarh 160019	{ 265 9930
Southern : C.I.T. Campus, IV Cross Road, Taramani, Chennai 600113	{ 2254 1442 2254 1216
Western : 5 th Floor/MTNL CETTM, Technology Street, Hiranandani Gardens, Powai Mumbai 400076	{ 25700030 25702715

Branches : AHMEDABAD, BENGALURU, BHOPAL, BHUBANESHWAR, CHANDIGARH, CHENNAI, COIMBATORE, DEHRADUN, DELHI, FARIDABAD, GHAZIABAD, GUWAHATI, HARYANA (CHANDIGARH), HUBLI, HYDERABAD, JAIPUR, JAMMU, JAMSHEDPUR, KOCHI, KOLKATA, LUCKNOW, MADURAI, MUMBAI, NAGPUR, NOIDA, PARWANOO, PATNA, PUNE, RAIPUR, RAJKOT, SURAT, VIJAYAWADA.