

वस्त्रादि — कृत्रिम रेशा धागा — विद्युत
प्रीतिरोध के मापन द्वारा इलेक्ट्रोस्टैटिक
प्रवृत्ति ज्ञात करना

(ISO 24180 : 2021, संशोधित)

Textiles — Synthetic Filament
Yarns — Electrostatic Propensity
Evaluation by Measuring
Electrical Resistance

(ISO 24180 : 2021, MOD)

ICS 59.080.20

© BIS 2024

© ISO 2021



भारतीय मानक ब्यूरो
BUREAU OF INDIAN STANDARDS
मानक भवन, 9 बहादुर शाह ज़फर मार्ग, नई दिल्ली - 110002
MANAK BHAVAN, 9 BAHADUR SHAH ZAFAR MARG
NEW DELHI - 110002

www.bis.gov.in www.standardsbis.in

November 2024

Price Group 7

NATIONAL FOREWORD

This Indian Standard which is modified adoption of ISO 24180 : 2021 'Textiles — Synthetic filament yarns — Electrostatic propensity evaluation by measuring electrical resistance' issued by the International Organization for Standardization (ISO) was adopted by the Bureau of Indian Standards on recommendation of the Physical Methods of Test Sectional Committee and approval of the Textiles Division Council.

The text of ISO standard has been approved as suitable for publication as Indian Standard without deviations. Certain conventions are, however, not identical to those used in Indian Standards. Attention is particularly drawn to the following:

- a) Wherever the words 'International Standard' appears referring to this standard, they should be read as 'Indian Standard'; and
- b) Comma (,) has been used as a decimal marker while in Indian Standards, the current practice is to use a point (.) as the decimal marker.

In this adopted standard, reference appears to the following International Standards for which Indian Standards also exist. The corresponding Indian Standards which are to be substituted in their respective places are given below along with its degree of equivalence for the editions indicated.

<i>International Standard</i>	<i>Corresponding Indian Standard</i>	<i>Degree of Equivalence</i>
ISO 139 Textiles — Standard atmospheres for conditioning and testing	IS 6359 : 2023 Method for conditioning of textiles (<i>first revision</i>)	Technically Equivalent
ISO 2060 Textiles — Yarn from packages — Determination of linear density (mass per unit length) by the skein method	IS 1315 : 1977 Method for determination of linear density of yarns spun on cotton system (<i>first revision</i>)	Modified

In reporting the result of a test or analysis made in accordance with this standard, if the final value, observed or calculated, is to be rounded off, it shall be done in accordance with IS 2 : 2022 'Rules for rounding off numerical values (*second revision*)'.

Contents

Page

1	Scope	1
2	Normative references	1
3	Terms and definitions	1
4	Principle	1
5	Apparatus	2
	5.1 DC high-resistance meter.....	2
	5.2 Insulating specimen holder (see Figure 1).....	2
	5.3 Tensioning weight.....	2
6	Atmosphere for conditioning and testing	2
7	Preparation of test specimens	3
	7.1 Preparation of specimens.....	3
	7.2 Conditioning.....	3
	7.2.1 Pre-conditioning.....	3
	7.2.2 Conditioning.....	3
8	Test procedure	3
	8.1 Tension for the test specimen.....	3
	8.2 Test specimen loading.....	3
	8.3 Determination of electrical resistance.....	4
9	Calculation and expression of results	4
	9.1 Resistance per unit length.....	4
	9.2 Volume resistivity.....	4
	9.3 Expression of results.....	4
	9.4 Precision.....	5
10	Test report	5
	Annex A (informative) Average density of common synthetic fibres	6
	Annex B (informative) Precision experiments	7
	Bibliography	9

*Indian Standard***TEXTILES — SYNTHETIC FILAMENT YARNS —
ELECTROSTATIC PROPENSITY EVALUATION BY MEASURING
ELECTRICAL RESISTANCE****(ISO 24180 : 2021, MOD)****1 Scope**

This document specifies methods for electrostatic propensity evaluation by measuring electrical resistance of synthetic filament yarns.

It is applicable to synthetic filament yarns. Conductive yarns covered in this document are used for anti-static fabric. They are not used for transmission of electric signals, supply of electric power and electromagnetic shield and heating.

2 Normative references

The following documents are referred to in the text in such a way that some or all of their content constitutes requirements of this document. For dated references, only the edition cited applies. For undated references, the latest edition of the referenced document (including any amendments) applies.

ISO 139, *Textiles — Standard atmospheres for conditioning and testing*

ISO 2060, *Textiles — Yarn from packages — Determination of linear density (mass per unit length) by the skein method*

3 Terms and definitions

For the purposes of this document, the following terms and definitions apply.

ISO and IEC maintain terminology databases for use in standardization at the following addresses:

- ISO Online browsing platform: available at <https://www.iso.org/obp>
- IEC Electropedia: available at <https://www.electropedia.org/>

3.1**electrical resistance per unit length**

electrical resistance of a material per unit length

Note 1 to entry: It is expressed in Ω/m .

3.2**volume resistivity**

quotient obtained when the potential gradient is divided by the current density

Note 1 to entry: It is expressed in $\Omega\cdot\text{m}$.

[SOURCE: ISO 472:2013/Amd.1:2018, 3.17, modified — Note 1 to entry has been deleted]

4 Principle

Resistivity is a physical quantity used to compare the conducting properties of different materials.

Under specific condition, electrical resistance of synthetic filament yarns in certain length is measured. Electrical resistance per unit length and volume resistivity are calculated.

5 Apparatus

5.1 DC high-resistance meter

- a) Resistance range: $1 \times 10^6 \Omega$ to $1 \times 10^{13} \Omega$.
- b) Accuracy: $\pm 5 \%$ for measurements of $1 \times 10^{12} \Omega$ and less, and $\pm 20 \%$ for higher than $1 \times 10^{12} \Omega$.
- c) Open circuit voltage: $(100 \pm 5) \text{ V}$.

5.2 Insulating specimen holder (see Figure 1)

- a) Insulating board, material resistance $\geq 10^{14} \Omega$ and with a pair of copper clamps in a horizontal spacing of $(10 \pm 0,1) \text{ cm}$ on it.
- b) Clamps, with clean and flat jaw faces to hold the test specimen without slippage.
- c) A pulley, on the outside of one clamp.
- d) Jaw faces of the clamps and upper edge of the pulley are at same horizontal plane.

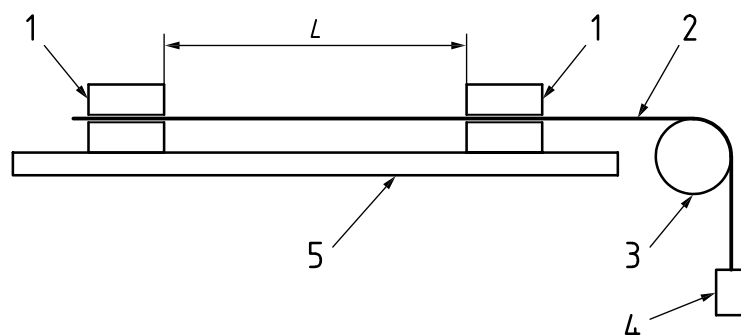

Key

- 1 clamps [5.2, b)]
- 2 specimen
- 3 pulley [5.2, c)]
- 4 tensioning weight (5.3)
- 5 insulating board [5.2, a)]
- L spacing between the two clamps [5.2, a)], expressed in cm.

Figure 1 — Schematic diagram of insulating specimen holder

5.3 Tensioning weight

With clamps, to apply tension force to test specimens.

6 Atmosphere for conditioning and testing

The atmosphere shall be a temperature of $(20 \pm 2) ^\circ\text{C}$ and a relative humidity of $(40 \pm 4) \%$. If a different temperature or humidity is used, record it in the test report.

NOTE The measurements of temperature and humidity are specified in ISO 139.

7 Preparation of test specimens

7.1 Preparation of specimens

Discard yarn on the outer layer of a package (about 1 g) and cut yarn to a length of 400 mm to 500 mm as the first test specimen.

Discard more yarn, about 3 m to 5 m, before cutting the next test specimen from the same package.

The minimum number of test specimens shall be 3 from each package.

If the resistance non-uniformity test is required, the total amount of test specimens is not less than 30.

7.2 Conditioning

7.2.1 Pre-conditioning

Before conditioning, pre-conditioning is required. Pre-conditioning shall be carried out in accordance with ISO 139.

7.2.2 Conditioning

Condition the specimens in atmosphere (see [Clause 6](#)) for at least 2 h until equilibrium is attained.

8 Test procedure

8.1 Tension for the test specimen

8.1.1 Tension per unit linear density is intended to be:

- non-texture yarns: $(0,05 \pm 0,01)$ cN/dtex;
- textured yarns: $(0,20 \pm 0,04)$ cN/dtex.

8.1.2 Calculate the tension according to [Formula \(1\)](#):

$$F = P \times T \tag{1}$$

where

F is the tension, expressed in cN;

P is the tension per unit linear density (see [8.1.1](#)), expressed in cN/dtex;

T is the linear density of the test specimen (specified in ISO 2060), expressed in dtex.

8.2 Test specimen loading

8.2.1 Place one end of the test specimen in the middle of the clamp nonadjacent to the pulley and close the clamp.

8.2.2 Place the other end in the middle of another clamp and lead the test specimen passing through the pulley.

Add sufficient weight (see [8.1](#)) on the end of the test specimen.

Be sure to keep the test specimen straight and close the clamp.

8.3 Determination of electrical resistance

8.3.1 Attach the measuring electrodes of the DC high-resistance meter to the two copper clamps, regardless of position.

The voltage switch is placed at 100 V.

If under non-specified voltage, it shall be indicated in the report.

8.3.2 Energize the resistance meter and read the value of electric resistance after 1 min.

8.3.3 Break off the voltage switch. Contact two clamps and ground, to enable electrostatic dissipation on the clamps.

8.3.4 Remove the test specimen from the clamps. Repeat measuring other test specimens.

9 Calculation and expression of results

9.1 Resistance per unit length

Calculate electrical resistance per unit length according to [Formula \(2\)](#).

$$R_L = \frac{R}{L} \times 10^2 \quad (2)$$

where

R_L is the resistance per unit length, expressed in Ω/m ;

R is the resistance of test specimen between the two clamps, expressed in Ω ;

L is the spacing between the two clamps, expressed in cm.

9.2 Volume resistivity

Calculate volume resistivity according to [Formula \(3\)](#).

$$S_V = \frac{R \times T}{L \times \rho} \times 10^{-8} \quad (3)$$

where

S_V is the the volume resistivity, expressed in $\Omega \cdot \text{m}$;

R is the resistance of test specimen between the two clamps, expressed in Ω ;

T is the linear density of sample (specified in ISO 2060), expressed in dtex;

L is the spacing between the two clamps, expressed in cm;

ρ is the density of fibre (see [Annex A](#)), expressed in g/cm^3 .

9.3 Expression of results

The result is expressed as arithmetic mean value or geometric mean value of all the test specimens.

The mean value is recorded in scientific notation $a \times 10^n$, in which a value is 1,0 to less than 10 and accurate to the first decimal place.

Usually, the average is calculated by arithmetic mean value.

The arithmetic mean value is calculated according to [Formula \(4\)](#).

$$\bar{X} = \sum_{i=1}^n x_i / n \quad (4)$$

where

\bar{X} is the arithmetic mean value of each test items;

x_i is the value of each test items;

n is the number of tests.

When the test value changes in order of magnitude, the geometric mean value is selected.

The geometric mean value is calculated according to [Formula \(5\)](#).

$$\bar{X} = \left(\prod_{i=1}^n x_i \right)^{1/n} \quad (5)$$

where

\bar{X} is the geometric mean value of each test items;

x_i is the value of each test items;

n is the number of tests.

9.4 Precision

See [Annex B](#).

10 Test report

The test report shall include at least the following information:

- a) the International Standard used (including its year of publication);
- b) all details necessary for the identification of the sample tested;
- c) test conditions;
- d) test results;
- e) any deviation, by agreement or otherwise, from the procedure specified;
- f) any unusual features observed;
- g) the date of the test;
- h) any information needs to be indicated.

Annex A (informative)

Average density of common synthetic fibres

A.1 Description

The density of the fibre is determined by a density gradient column method (ISO 1183-2). The temperature of liquid bath is $(25 \pm 0,5)$ °C.

A.2 Average density

The average density of common synthetic fibres are recommend as listed in [Table A.1](#).

Table A.1 — Average density of common synthetic fibres

Type of the fibres	Density value (g/cm ³)	Type of the fibres	Density value (g/cm ³)
polyester PET	1,38	polyethylene	0,96
acrylic	1,18	polypropylene	0,91
modacrylic	1,28	phenolic	1,31
para-aramid	1,46	polysulfonamide	1,37
polyamide	1,14	polyvinyl chloride	1,38
vinylal	1,24	casein modified polyacrylonitrile	1,26
polyvinylidene chloride	1,70	polylactide	1,27
elastane	1,23	—	—

Annex B (informative)

Precision experiments

B.1 Description

Ten laboratories participated in the experiment, providing test results for six materials and each one repeated twice. Results are analysed according to ISO 5725-2.

B.2 Repeatability

Following the normal and the right operation method specified in this document, one operator, using the same apparatus, tests identical specimens in an appropriate short time and calculates the difference of any two mean values.

Determine 20 cases and only once is above the repeatability listed in [Table B.1](#).

B.3 Reproducibility

Following the normal and the right operation method specified in this document, operators in two laboratories, using different apparatus, tests identical specimens and calculates the difference of any two mean values.

Determine 20 cases and only once is above the reproducibility listed in [Table B.1](#).

Table B.1 — Precision of test results in six materials

Sample	Specifications	Electrical resistance per unit length (Ω/m)		Volume resistivity ($\Omega \cdot m$)	
		repeatability	reproducibility	repeatability	reproducibility
		r	R	r	R
conductive Polyester filament yarns	22dtex/3f	$1,2 \times 10^{11}$	$4,0 \times 10^{11}$	$1,9 \times 10^2$	$6,4 \times 10^2$
conductive Polyester filament yarns	55.5dtex/8f	$3,4 \times 10^8$	$2,7 \times 10^9$	$1,4 \times 10^0$	$1,1 \times 10^1$
conductive Polyamide 6 filament yarns	22dtex/1f	$2,1 \times 10^{10}$	$7,8 \times 10^{10}$	$4,1 \times 10^1$	$1,5 \times 10^2$
conductive Polyamide 6 filament yarns	22dtex/3f	$6,2 \times 10^9$	$2,0 \times 10^{10}$	$1,2 \times 10^1$	$3,9 \times 10^1$
Polyester industrial filament yarns	1 100dtex/192f	$4,4 \times 10^{14}$	$3,6 \times 10^{15}$	$3,5 \times 10^7$	$2,9 \times 10^8$
Polyamide 66 industrial filament yarns	1 400dtex/208f	$9,0 \times 10^{13}$	$6,7 \times 10^{14}$	$1,1 \times 10^8$	$8,2 \times 10^8$

B.4 Mean value

Test two specimens and calculate arithmetic mean values. When the test value changes in order of magnitude, the geometric mean value is selected.

If the difference equals or exceeds the repeatability and reproducibility listed in [Table B.1](#), two mean values should be considered significantly different at the 95 % probability level.

Bibliography

- [1] ISO 1183-2, *Plastics — Methods for determining the density of non-cellular plastics — Part 2: Density gradient column method*
- [2] ISO 2076, *Textiles — Man-made fibres — Generic names*
- [3] ISO 5725-2, *Accuracy (trueness and precision) of measurement methods and results — Part 2: Basic method for the determination of repeatability and reproducibility of a standard measurement method*
- [4] ISO 13931, *Carbon fibre — Determination of volume resistivity*
- [5] IEC 61340-2-3, *Electrostatics — Part 2-3: Methods of test for determining the resistance and resistivity of solid materials used to avoid electrostatic charge accumulation*
- [6] FZ/T 01057.7, *Test method for identification of textile fibres — Part 7: Density gradient column method*
- [7] FZ/T 50035, *Synthetic filament yarns — Test method for electric resistance*

Bureau of Indian Standards

BIS is a statutory institution established under the *Bureau of Indian Standards Act, 2016* to promote harmonious development of the activities of standardization, marking and quality certification of goods and attending to connected matters in the country.

Copyright

BIS has the copyright of all its publications. No part of these publications may be reproduced in any form without the prior permission in writing of BIS. This does not preclude the free use, in the course of implementing the standard, of necessary details, such as symbols and sizes, type or grade designations. Enquiries relating to copyright be addressed to the Head (Publication & Sales), BIS.

Review of Indian Standards

Amendments are issued to standards as the need arises on the basis of comments. Standards are also reviewed periodically; a standard along with amendments is reaffirmed when such review indicates that no changes are needed; if the review indicates that changes are needed, it is taken up for revision. Users of Indian Standards should ascertain that they are in possession of the latest amendments or edition by referring to the website-www.bis.gov.in or www.standardsbis.in.

This Indian Standard has been developed from Doc No.: TXD 01 (25573).

Amendments Issued Since Publication

Amend No.	Date of Issue	Text Affected

BUREAU OF INDIAN STANDARDS

Headquarters:

Manak Bhavan, 9 Bahadur Shah Zafar Marg, New Delhi 110002

Telephones: 2323 0131, 2323 3375, 2323 9402

Website: www.bis.gov.in

Regional Offices:

Central : 601/A, Konnectus Tower -1, 6th Floor,
DMRC Building, Bhavbhuti Marg, New
Delhi 110002

Telephones

{ 2323 7617

Eastern : 8th Floor, Plot No 7/7 & 7/8, CP Block, Sector V,
Salt Lake, Kolkata, West Bengal 700091

{ 2367 0012
2320 9474

Northern : Plot No. 4-A, Sector 27-B, Madhya Marg,
Chandigarh 160019

{ 265 9930

Southern : C.I.T. Campus, IV Cross Road, Taramani, Chennai 600113

{ 2254 1442
2254 1216

Western : Manakalya, 5th Floor/MTNL CETTM, Technology Street, Hiranandani Gardens, Powai
Mumbai 400076

{ 25700030
25702715

Branches : AHMEDABAD, BENGALURU, BHOPAL, BHUBANESHWAR, CHANDIGARH, CHENNAI, COIMBATORE, DEHRADUN, DELHI, FARIDABAD, GHAZIABAD, GUWAHATI, HARYANA (CHANDIGARH), HUBLI, HYDERABAD, JAIPUR, JAMMU, JAMSHEDPUR, KOCHI, KOLKATA, LUCKNOW, MADURAI, MUMBAI, NAGPUR, NOIDA, PARWANOO, PATNA, PUNE, RAIPUR, RAJKOT, SURAT, VIJAYAWADA.