

ट्रैक्टर और ट्रेलर के बीच वैक्यूम और दबाव
प्रणाली कनेक्शन के लिए 'संपर्क' प्रकार की
कपलिंग — विशिष्टि
(पहला पुनरीक्षण)

'Contact' Type Coupling for Vacuum
and Pressure Systems Connection
Between Tractor and Trailer —
Specification
(First Revision)

ICS 43.040.70

© BIS 2024



भारतीय मानक ब्यूरो
BUREAU OF INDIAN STANDARDS
मानक भवन, 9 बहादुर शाह ज़फर मार्ग, नई दिल्ली - 110002
MANAK BHAVAN, 9 BAHADUR SHAH ZAFAR MARG
NEW DELHI - 110002

www.bis.gov.in www.standardsbis.in

FOREWORD

This Indian Standard (First Revision) was adopted by the Bureau of Indian Standards, after the draft finalized by the Transport Tractors, Trailers and Industrial Trucks Sectional Committee and had been approved by the Transport Engineering Division Council.

In the preparation of this standard, assistance has been derived from BS AU 5 : 1963 'Specification for dimensions of a 'contact' type coupling for vacuum and pressure braking systems on trailers and semi-trailers', issued by the British Standards Institution (BSI).

This standard was first published in 1988. This revision has been brought out to incorporate the experience gained with the use of this standard and brings the standard in line with the latest development in the field.

The composition of the Committee responsible for the formulation of this standard is given in [Annex A](#).

For the purpose of deciding whether a particular requirement of this standard is complied with, the final value, observed or calculated, expressing the result of test or analysis, shall be rounded off in accordance with IS 2 : 2022 'Rules for rounding off numerical values (*second revision*)'. The number of significant places retained in the rounded off value should be the same as that of the specified value in this standard.

Indian Standard

‘CONTACT’ TYPE COUPLING FOR VACUUM AND PRESSURE SYSTEMS CONNECTION BETWEEN TRACTOR AND TRAILER — SPECIFICATION

(First Revision)

1 SCOPE

This standard specifies the form and dimensions of ‘contact’ type coupling for vacuum and pressure systems connection between tractor and trailer.

NOTE — Coupling for braking system shall be according to IS 9905.

2 REFERENCES

The standard given below contain provisions which, through reference in this text, constitutes provision of this standard. At the time of publication, the edition indicated was valid. All standard are subject to revision, and parties to agreements based on this standard are encouraged to investigate the possibility of applying the most recent edition of this standard:

<i>IS No.</i>	<i>Title</i>
IS 9905 : 1981	Specification for pneumatic coupling between tractors and trailers

3 DIMENSIONAL

3.1 The dimensions and general arrangements of ‘contact’ type coupling shall be as shown in [Fig. 1](#), [Fig. 2](#) and [Fig. 3](#).

4 BIS CERTIFICATION MARKING

The product(s) conforming to the requirements of this standard may be certified as per the conformity assessment schemes under the provisions of the *Bureau of Indian Standards Act, 2016* and the Rules and Regulations framed thereunder, and the products may be marked with the Standard Mark.

THIS CENTRE LINE CORRESPONDS
WITH CENTRES OF HOLES FOR LOCKING
BALLS SHOWN IN FIG. 2

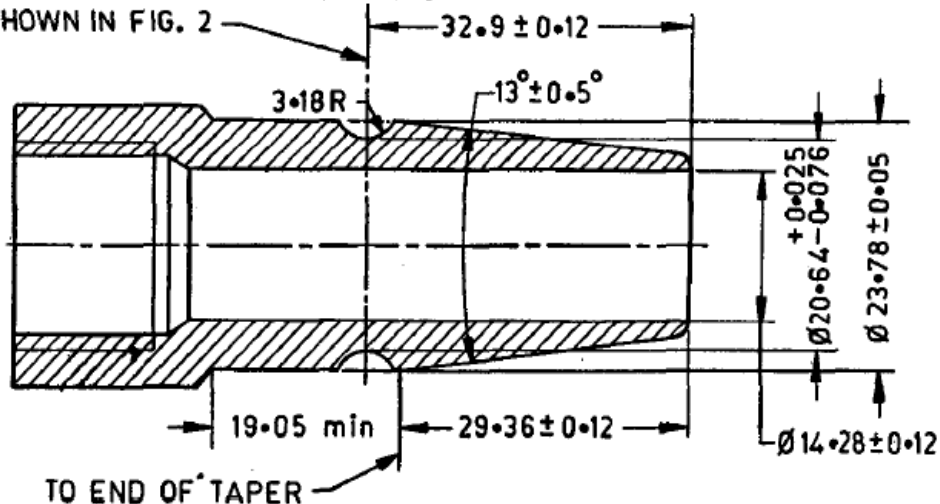

All dimensions in millimetres.

FIG. 1 MALE MEMBER

To access Indian Standards click on the link below:

https://www.services.bis.gov.in/php/BIS_2.0/bisconnect/knownyourstandards/Indian_standards/isdetails/

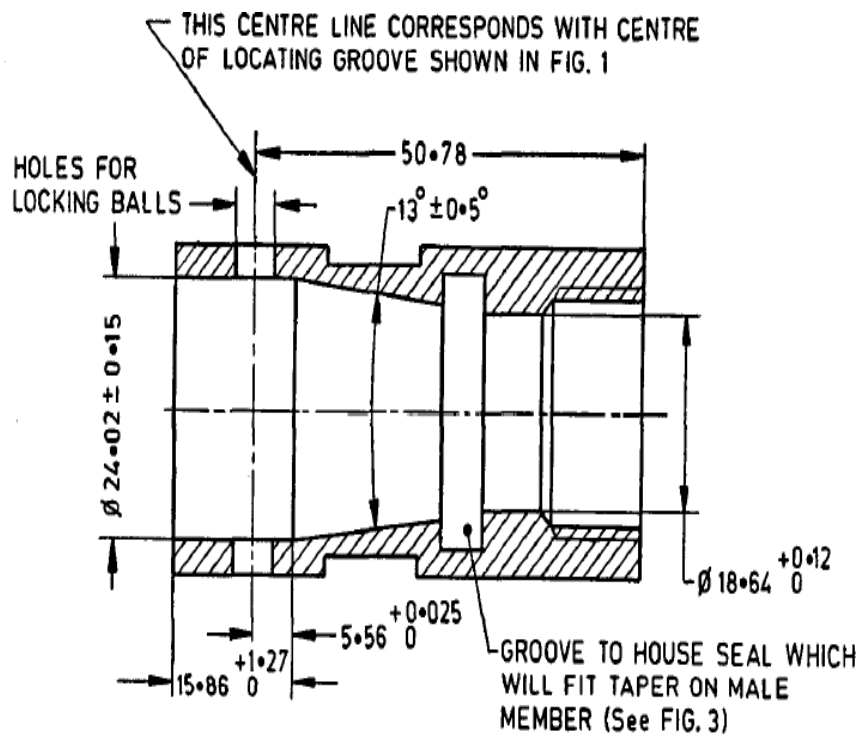

All dimensions in millimetres.
FIG. 2 FEMALE MEMBER

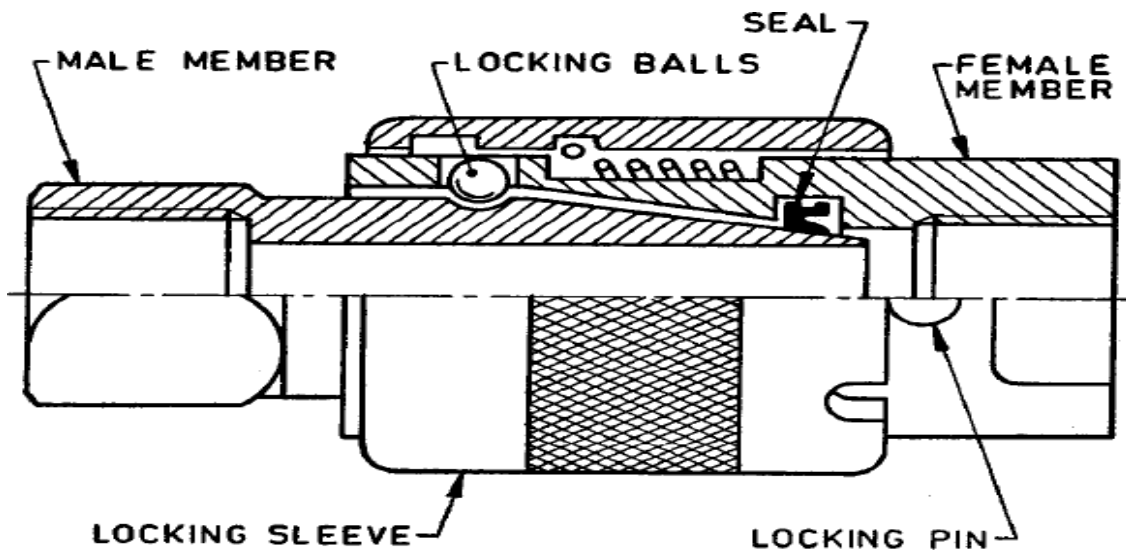

FIG. 3 HALF SECTIONED GENERAL ARRANGEMENT OF CONTACT COUPLING

ANNEX A

(Foreword)

COMMITTEE COMPOSITION

Transport Tractors, Trailers and Industrial Trucks Sectional Committee, TED 22

<i>Organization</i>	<i>Representative(s)</i>
Automotive Research Association of India, Pune	SHRI A. AKBAR BADUSHA (Chairperson)
BEML Limited, Bengaluru	SHRI RAMESH RAJU SHRI SETHU MADHAVAN (<i>Alternate</i>)
Action Construction Equipment Limited, Palwal	SHRI CHETAN GOLE SHRI INDERPAL SINGH BENIWAL (<i>Alternate</i>)
All India Motor Transport Congress, New Delhi	SHRI NAVEEN GUPTA SHRI S. K. MITTAL (<i>Alternate</i>)
Ashok Leyland Limited, Chennai	SHRI PRASANNA VENKATESH SHRI FAUSTINO V. (<i>Alternate</i>)
Automotive Component Manufactures Association of India, New Delhi	SHRI UDAY HARITE SHRI JITENDER RANA (<i>Alternate</i>)
Automotive Research Association of India, Pune	SHRI P. D. BETGERI SHRI TUSHARKUMAR R. KAMBLE (<i>Alternate</i>)
Black Diamond Motors Private. Limited, Bilaspur	SHRI JACOB THOMAS SHRI TANMAY GANGULY (<i>Alternate</i>)
Brakes India Limited, Chennai	SHRI P. VENUGOPAL SHRI G. DEVENDRAN (<i>Alternate</i>)
Central Institute of Road Transport, Pune	SHRI S. N. DHOLE SHRI S. N. GUTTE (<i>Alternate</i>)
Department of Heavy Industry, New Delhi, Ministry of Heavy Industries and Public Enterprises,	SHRI B. K. MISHRA SHRI R. K. JAISWAL (<i>Alternate</i>)
Directorate General Factory Advice Service and Labour Institutes, Mumbai	SHRI N. VARADHARAJAN SHRI KARUNESH SRIVASTAVA (<i>Alternate</i>)
Global Automotive Research Centre, Oragaram	SHRI. A. S. RAMADHAS SHRI V. M. DHANASEKKAR (<i>Alternate</i>)
Godrej & Boyce Manufacturing Company Limited, Mumbai	SHRI VINAY G. KULKARNI SHRI ANAND SHANKAR TAWDE (<i>Alternate</i>)
International Centre for Automotive Technology, Manesar	SHRI KESHAV KUMAR TRIPATHI SHRI GAVENDRA SINGH (<i>Alternate</i>)
JCB India Limited, New Delhi	SHRI SAURABH DALELA SHRI ALOK GANDHI (<i>Alternate</i>)

<i>Organization</i>	<i>Representative(s)</i>
Josts Engineering Company Limited, Thane	SHRI PRAMOD M. POPHALE SHRI SANTOSH SARAF (<i>Alternate</i>)
KION India Private Limited, Pune	SHRI SUNIL K. GUPTA SHRI RIZWAN KHAN (<i>Alternate</i>)
Knorr-Bremse Systems for Commercial Vehicles India Private Limited, Pune	SHRI ARUN BISHT SHRI ATUL INGOLE (<i>Alternate</i>)
Machine and Mill Stores Corporation Private Limited, Howrah	SHRI DIPAK GHOSH
Mahindra Trucks and Bus Division, Pune	SHRI NAGARAJU K. SHRI V. G. KULKARNI (<i>Alternate</i>)
Ministry of Labour and Employment Directorate, Mumbai	DR R. N. MEENA SHRI K. DURAI (<i>Alternate</i>)
Ministry of Road Transport and Highways, New Delhi	MS DHARKAT R. LUIKANG
National Automotive Test Tracks, Dhar	SHRI SAGAR BENDRE SHRI J. K. CHAKRABARTY (<i>Alternate</i>)
Satrac Engineering Private Limited, Bangalore	SHRI SANTHANA KRISHNAN S. SHRI NITHIN KUMAR (<i>Alternate</i>)
SDR Auto Private Limited, Chennai	SHRI B. RAMESH SHRI PRAVEEN KUMAR (<i>Alternate</i>)
Tata International Vehicle Applications Private Limited, Pune	SHRI PARIKSHIT ABHIMANYU BHASKAR SHRI KRISHNA PRASAD (<i>Alternate</i>)
Tata Motors Limited, Pune	SHRI RAHUL MOHANRAO PATHAK SHRI SUNIL AGARWAL (<i>Alternate</i>)
Transport Engineering Solutions India Private Limited, Pune	SHRI MANOJ VARGHESE SHRI ANAND SINGH (<i>Alternate</i>)
Volvo Trucks, VE Commercial Vehicles Limited, Bengaluru	SHRI CHALLAPALLI NITHIN ROY SHRI GEDELA CHAITANYA (<i>Alternate</i>)
ZF Commercial Vehicle Control Systems India Limited, Pune	SHRI S. BALACHANDRAN SHRI KULDEEP SINGH (<i>Alternate</i>)
BIS Directorate General	SHRI DEEPAK AGGARWAL, SCIENTIST 'F'/ DIRECTOR AND HEAD (TRANSPORT ENGINEERING) [REPRESENTING DIRECTOR GENERAL (<i>Ex-officio</i>)]

Member Secretary
SHRI MITRA SEN VERMA
SCIENTIST 'D'/JOINT DIRECTOR
(TRANSPORT ENGINEERING), BIS

Bureau of Indian Standards

BIS is a statutory institution established under the *Bureau of Indian Standards Act, 2016* to promote harmonious development of the activities of standardization, marking and quality certification of goods and attending to connected matters in the country.

Copyright

BIS has the copyright of all its publications. No part of these publications may be reproduced in any form without the prior permission in writing of BIS. This does not preclude the free use, in the course of implementing the standard, of necessary details, such as symbols and sizes, type or grade designations. Enquiries relating to copyright be addressed to the Head (Publication & Sales), BIS.

Review of Indian Standards

Amendments are issued to standards as the need arises on the basis of comments. Standards are also reviewed periodically; a standard along with amendments is reaffirmed when such review indicates that no changes are needed; if the review indicates that changes are needed, it is taken up for revision. Users of Indian Standards should ascertain that they are in possession of the latest amendments or edition by referring to the website-www.bis.gov.in or www.standardsbis.in.

This Indian Standard has been developed from Doc No.: TED 22 (23017).

Amendments Issued Since Publication

Amend No.	Date of Issue	Text Affected

BUREAU OF INDIAN STANDARDS

Headquarters:

Manak Bhavan, 9 Bahadur Shah Zafar Marg, New Delhi 110002

Telephones: 2323 0131, 2323 3375, 2323 9402

Website: www.bis.gov.in

Regional Offices:

Central : 601/A, Konnectus Tower -1, 6th Floor,
DMRC Building, Bhavbhuti Marg, New
Delhi 110002

Telephones

{ 2323 7617

Eastern : 8th Floor, Plot No 7/7 & 7/8, CP Block, Sector V,
Salt Lake, Kolkata, West Bengal 700091

{ 2367 0012
2320 9474

Northern : Plot No. 4-A, Sector 27-B, Madhya Marg,
Chandigarh 160019

{ 265 9930

Southern : C.I.T. Campus, IV Cross Road, Taramani, Chennai 600113

{ 2254 1442
2254 1216

Western : 5th Floor/MTNL CETTM, Technology Street, Hiranandani Gardens, Powai
Mumbai 400076

{ 25700030
25702715

Branches : AHMEDABAD, BENGALURU, BHOPAL, BHUBANESHWAR, CHANDIGARH, CHENNAI, COIMBATORE, DEHRADUN, DELHI, FARIDABAD, GHAZIABAD, GUWAHATI, HARYANA (CHANDIGARH), HUBLI, HYDERABAD, JAIPUR, JAMMU, JAMSHEDPUR, KOCHI, KOLKATA, LUCKNOW, MADURAI, MUMBAI, NAGPUR, NOIDA, PARWANOO, PATNA, PUNE, RAIPUR, RAJKOT, SURAT, VIJAYAWADA.