

16 टन तक सकल द्रव्यमान के ट्रेलरों और
परिवहन ट्रैक्टरों के बीच उपयोग के लिए
टोइंग जॉ — विशिष्टि

(पहला पुनरीक्षण)

Towing Jaw for Use Between
Trailers of Up To 16 Tonnes Gross
Mass and Transport Tractor —
Specification

(First Revision)

ICS 43.040.70

© BIS 2024



भारतीय मानक ब्यूरो
BUREAU OF INDIAN STANDARDS
मानक भवन, 9 बहादुर शाह ज़फर मार्ग, नई दिल्ली - 110002
MANAK BHAVAN, 9 BAHADUR SHAH ZAFAR MARG
NEW DELHI - 110002

www.bis.gov.in www.standardsbis.in

FOREWORD

This Indian Standard (First Revision) was adopted by the Bureau of Indian Standards, after the draft finalized by the Transport Tractors, Trailers and Industrial Trucks Sectional Committee had been approved by the Transport Engineering Division Council.

This standard was first published in 1976. This revision has been brought out to incorporate the experience gained with the use of this standard and brings the standard in line with the latest development in the field. This standard supersedes IS 8297 : 1976.

The requirements of this standard, which relate only to vehicles used on the public highways, are intended to ensure the maximum degree of compatibility between commercial and government department standards. Towing jaws may be forged or cast.

The material specifications are for the minimum qualities acceptable, and do not exclude the use of other materials provided that these are at least equal in quality so that road safety is not impaired.

This standard should be used in conjunction with IS 8274 : 1976. The jaw has been designed to accommodate a drawbar eye of 51 mm internal diameter and 40 mm stock or 76 mm internal diameter and 40 mm stock.

The standard applies to connections to trailers of up to 16 tonnes gross mass. The specification for a towing jaw for connections to trailer of up to 35 tonnes gross mass is given in IS 8296 : 1976 and for trailers of up to 5 tonnes gross mass is given in IS 8298 : 1976.

In the preparation of this standard, considerable assistance has been derived from BS AU 26 : 1964 'Specification for towing jaw for use between trailers of 5 tonnes to 16 tonnes gross weight and towing vehicle', issued by the British Standards Institution (BSI).

The composition of the committee responsible for formulation of this standard is given in [Annex A](#).

For the purpose of deciding whether a particular requirement of this standard is complied with, the final value, observed or calculated expressing the result of a test or analysis, shall be rounded off in accordance with IS 2 : 2022 'Rules for rounding off numerical values (*second revision*)'. The number of significant places retained in the rounded off value should be the same as that of the specified value in this standard.

Indian Standard

TOWING JAW FOR USE BETWEEN TRAILERS OF UP TO 16 TONNES GROSS MASS AND TRANSPORT TRACTOR — SPECIFICATION

*(First Revision)***1 SCOPE**

1.1 This standard specifies the basic dimensions and quality of materials for a towing jaw and its mountings, for use in connection between a transport tractor and a trailer of up to 16 tonnes gross mass.

1.2 The gross mass refers to gross laden train masses where more than one trailer is drawn.

2 REFERENCES

The standards given below contain provisions which, through reference in this text, constitute provision of this standard. At the time of publication, the editions indicated were valid. All standards are subject to revision, and parties to agreements based on this standard are encouraged to investigate the possibility of applying the most recent edition of these standards:

<i>IS No</i>	<i>Title</i>
IS 1875 : 1992	Carbon steel billets, blooms, slabs and bars for forgings — Specification (<i>fifth revision</i>)
IS 1030 : 1998	Carbon steel castings for general engineering purposes — Specification (<i>fifth revision</i>)
IS 5517 : 1993	Steels for hardening and tempering — Specification (<i>second revision</i>)
IS 8299 : 1976	Specification for towing hook for use between trailers of up to 16 tonnes gross mass and transport tractor
IS 8300 : 1976	Specification for towing hook for use between trailers of up to 35 tonnes gross mass and transport tractor
IS 1364 (Part 1) : 2018/ISO 4014 : 2011	Hexagon head bolts, screws and nuts of product grades A and B: Part 1 Hexagon head bolts (size range M 1.6 to M 64) (<i>fifth revision</i>)

3 MATERIALS

3.1 The jaw shall be made from a material of quality not less than Grade C20 of IS 1875 for steel in normalized condition for the forged jaw and Grade 23 to 45 of IS 1030 for the cast jaw.

3.2 The towing pin shall be made from a material of quality not less than Grade 35Mn2Mo 28 steel of IS 5517.

4 DIMENSIONS

Dimensions shall be as shown in [Fig. 1](#). The dimensions marked with asterisk (*) in [Fig. 1](#) are essential for interchangeability, other dimensions apply to the forged jaw and are for guidance only.

NOTE — The dimensions specified for the forged jaws have been calculated on the basis of the total yield strength being not less than two-thirds the gross mass being towed. It is necessary that any other part not covered by this standard, connecting the coupling to the towing tractor shall have a similar strength.

5 DESIGN

5.1 An efficient safety locking device shall be provided as indicated in [Fig. 1](#) to prevent accidental extraction of the towing pin from the jaw.

5.2 The jaw shall be so designed that a bar of 44 mm diameter shall pass freely between the pin and the inside face of the jaw (*see Fig. 1*).

6 MOUNTING

6.1 The jaw shall be mounted with four bolts of 16 mm diameter conforming to designation M 16 × 1.5 (P) of IS 1364 (Part 1) at 100.0 mm × 100.0 mm centres. This renders it interchangeable in mounting with hooks specified in IS 8299 and IS 8300.

6.2 The nuts shall be secured either by peening the end of the bolt or by fitting a positive locking device such as a- safe locking nut or a slotted nut and split pin.

To access Indian Standards click on the link below:

https://www.services.bis.gov.in/php/BIS_2.0/bisconnect/knownyourstandards/Indian_standards/isdetails/

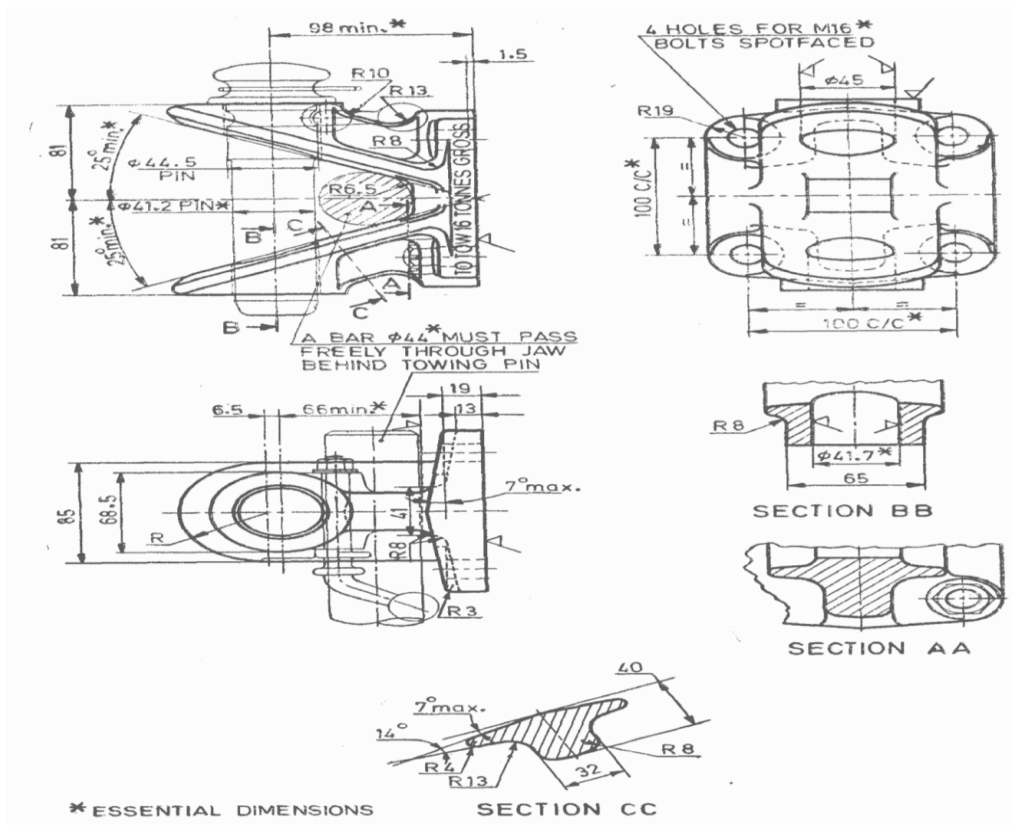

All dimensions in millimetres.

FIG. 1 TOWING JAW FOR TRAILERS UPTO 16 TONNES

7 MARKING

7.1 The following wording, in clear lettering 10 mm high, raised or stamped, shall be marked on each towing jaw:

- 'TO TOW 16 TONNES GROSS' on one side; and
- IS 8297 on the other side.

7.2 In addition, the towing jaws shall also be marked at the appropriate place, the following information

- Name or trade-mark of the manufacturer;

- Date or year of manufacture; and
- The country of manufacture.

7.3 BIS Certification Marking

The product(s) conforming to the requirements of this standard may be certified as per the conformity assessment schemes under the provisions of the *Bureau of Indian Standards Act, 2016* and the Rules and Regulations framed thereunder, and the products may be marked with the Standard Mark.

ANNEX A

(Foreword)

COMMITTEE COMPOSITION

Transport Tractors, Trailers and Industrial Trucks Sectional Committee, TED 22

<i>Organization</i>	<i>Representative(s)</i>
Automotive Research Association of India, Pune	SHRI A. AKBAR BADUSHA (Chairperson)
BEML Limited, Bengaluru	SHRI RAMESH RAJU SHRI SETHU MADHAVAN (<i>Alternate</i>)
Action Construction Equipment Limited, Palwal	SHRI CHETAN GOLE SHRI INDERPAL SINGH BENIWAL (<i>Alternate</i>)
All India Motor Transport Congress, New Delhi	SHRI NAVEEN GUPTA SHRI S. K. MITTAL (<i>Alternate</i>)
Ashok Leyland Limited, Chennai	SHRI PRASANNA VENKATESH SHRI FAUSTINO V. (<i>Alternate</i>)
Automotive Component Manufactures Association of India, New Delhi	SHRI UDAY HARITE SHRI JITENDER RANA (<i>Alternate</i>)
Automotive Research Association of India, Pune	SHRI P. D. BETGERI SHRI TUSHARKUMAR R. KAMBLE (<i>Alternate</i>)
Black Diamond Motors Private. Limited, Bilaspur	SHRI JACOB THOMAS SHRI TANMAY GANGULY (<i>Alternate</i>)
Brakes India Limited, Chennai	SHRI P. VENUGOPAL SHRI G. DEVENDRAN (<i>Alternate</i>)
Central Institute of Road Transport, Pune	SHRI S. N. DHOLE SHRI S. N. GUTTE (<i>Alternate</i>)
Department of Heavy Industry, New Delhi, Ministry of Heavy Industries and Public Enterprises,	SHRI B. K. MISHRA SHRI R. K. JAISWAL (<i>Alternate</i>)
Directorate General Factory Advice Service and Labour Institutes, Mumbai	SHRI N. VARADHARAJAN SHRI KARUNESH SRIVASTAVA (<i>Alternate</i>)
Global Automotive Research Centre, Oragaram	SHRI. A. S. RAMADHAS SHRI V. M. DHANASEKKAR (<i>Alternate</i>)
Godrej & Boyce Manufacturing Company Limited, Mumbai	SHRI VINAY G. KULKARNI SHRI ANAND SHANKAR TAWDE (<i>Alternate</i>)
International Centre for Automotive Technology, Manesar	SHRI KESHAV KUMAR TRIPATHI SHRI GAVENDRA SINGH (<i>Alternate</i>)
JCB India Limited, New Delhi	SHRI SAURABH DALELA SHRI ALOK GANDHI (<i>Alternate</i>)

<i>Organization</i>	<i>Representative(s)</i>
Josts Engineering Company Limited, Thane	SHRI PRAMOD M. POPHALE SHRI SANTOSH SARAF (<i>Alternate</i>)
KION India Private Limited, Pune	SHRI SUNIL K. GUPTA SHRI RIZWAN KHAN (<i>Alternate</i>)
Knorr-Bremse Systems for Commercial Vehicles India Private Limited, Pune	SHRI ARUN BISHT SHRI ATUL INGOLE (<i>Alternate</i>)
Machine and Mill Stores Corporation Private Limited, Howrah	SHRI DIPAK GHOSH SHRI SUBHAM GHOSH
Mahindra Trucks and Bus Division, Pune	SHRI NAGARAJU K. SHRI V. G. KULKARNI (<i>Alternate</i>)
Ministry of Labour and Employment Directorate, Mumbai	DR R. N. MEENA SHRI K. DURAI (<i>Alternate</i>)
Ministry of Road Transport and Highways, New Delhi	SHRI A. KANNAN MS DHARKAT R. LUIKANG (<i>Alternate I</i>) SHRI SAM SHAIKH (<i>Alternate II</i>)
National Automotive Test Tracks, Dhar	SHRI SAGAR BENDRE SHRI J. K. CHAKRABARTY (<i>Alternate</i>)
Satrac Engineering Private Limited, Bangalore	SHRI SANTHANA KRISHNAN S. SHRI NITHIN KUMAR (<i>Alternate</i>)
SDR Auto Private Limited, Chennai	SHRI B. RAMESH SHRI PRAVEEN KUMAR (<i>Alternate</i>)
Tata International Vehicle Applications Private Limited, Pune	SHRI PARIKSHIT ABHIMANYU BHASKAR SHRI KRISHNA PRASAD (<i>Alternate</i>)
Tata Motors Limited, Pune	SHRI RAHUL MOHANRAO PATHAK SHRI SUNIL AGARWAL (<i>Alternate</i>)
Transport Engineering Solutions India Private Limited, Pune	SHRI MANOJ VARGHESE SHRI ANAND SINGH (<i>Alternate</i>)
Volvo Trucks, VE Commercial Vehicles Limited, Bengaluru	SHRI CHALLAPALLI NITHIN ROY SHRI GEDELA CHAITANYA (<i>Alternate</i>)
ZF Commercial Vehicle Control Systems India Limited, Pune	SHRI S. BALACHANDRAN SHRI KULDEEP SINGH (<i>Alternate</i>)
BIS Directorate General	SHRI DEEPAK AGGARWAL, SCIENTIST 'F'/ DIRECTOR AND HEAD (TRANSPORT ENGINEERING) [REPRESENTING DIRECTOR GENERAL (<i>Ex-officio</i>)]

Member Secretary
SHRI MITRA SEN VERMA
SCIENTIST 'D'/JOINT DIRECTOR
(TRANSPORT ENGINEERING), BIS

Bureau of Indian Standards

BIS is a statutory institution established under the *Bureau of Indian Standards Act, 2016* to promote harmonious development of the activities of standardization, marking and quality certification of goods and attending to connected matters in the country.

Copyright

BIS has the copyright of all its publications. No part of these publications may be reproduced in any form without the prior permission in writing of BIS. This does not preclude the free use, in the course of implementing the standard, of necessary details, such as symbols and sizes, type or grade designations. Enquiries relating to copyright be addressed to the Head (Publication & Sales), BIS.

Review of Indian Standards

Amendments are issued to standards as the need arises on the basis of comments. Standards are also reviewed periodically; a standard along with amendments is reaffirmed when such review indicates that no changes are needed; if the review indicates that changes are needed, it is taken up for revision. Users of Indian Standards should ascertain that they are in possession of the latest amendments or edition by referring to the website-www.bis.gov.in or www.standardsbis.in.

This Indian Standard has been developed from Doc No.: TED 22 (19074).

Amendments Issued Since Publication

Amend No.	Date of Issue	Text Affected

BUREAU OF INDIAN STANDARDS

Headquarters:

Manak Bhavan, 9 Bahadur Shah Zafar Marg, New Delhi 110002

Telephones: 2323 0131, 2323 3375, 2323 9402

Website: www.bis.gov.in

Regional Offices:

Central : 601/A, Konnectus Tower -1, 6th Floor,
DMRC Building, Bhavbhuti Marg, New
Delhi 110002

Telephones

{ 2323 7617

Eastern : 8th Floor, Plot No 7/7 & 7/8, CP Block, Sector V,
Salt Lake, Kolkata, West Bengal 700091

{ 2367 0012
{ 2320 9474

Northern : Plot No. 4-A, Sector 27-B, Madhya Marg,
Chandigarh 160019

{ 265 9930

Southern : C.I.T. Campus, IV Cross Road, Taramani, Chennai 600113

{ 2254 1442
{ 2254 1216

Western : 5th Floor/MTNL CETTM, Technology Street, Hiranandani Gardens, Powai
Mumbai 400076

{ 25700030
{ 25702715

Branches : AHMEDABAD, BENGALURU, BHOPAL, BHUBANESHWAR, CHANDIGARH, CHENNAI, COIMBATORE, DEHRADUN, DELHI, FARIDABAD, GHAZIABAD, GUWAHATI, HARYANA (CHANDIGARH), HUBLI, HYDERABAD, JAIPUR, JAMMU, JAMSHEDPUR, KOCHI, KOLKATA, LUCKNOW, MADURAI, MUMBAI, NAGPUR, NOIDA, PARWANOO, PATNA, PUNE, RAIPUR, RAJKOT, SURAT, VIJAYAWADA.