साइकिलें — पैडल समुच्चय — विशिष्टि
(तीसरा पुनरीक्षण)

**Bicycles — Pedal Assembly —
Specification**
(*Third Revision*)

ICS 43.150

© BIS 2024



भारतीय मानक ब्यूरो
BUREAU OF INDIAN STANDARDS
मानक भवन, 9 बहादुर शाह ज़फर मार्ग, नई दिल्ली - 110002
MANAK BHAVAN, 9 BAHADUR SHAH ZAFAR MARG
NEW DELHI - 110002
www.bis.gov.in www.standardsbis.in

FOREWORD

This Indian (Third Revision) Standard was adopted by the Bureau of Indian Standards, after the draft finalized by the Bicycles Sectional Committee had been approved by Transport Engineering Division Council.

This standard was first published in 1955 and revised in 1963 and 1993. In this revision, following significant changes have been made:

- a) More choices of materials have been allowed;
- b) More number of shapes have been included; and
- c) New tests such as durability test, Impact test and Toxicity test have been specified.

The composition of the Committee responsible for the formulation of this standard is given in [Annex B](#).

For the purpose of deciding whether a particular requirement of this Standard has complied with the final value, observed or calculated, expressing the result of a test or analysis shall be rounded off as per IS 2 : 2022 'Rules for rounding off numerical values (*second revision*)'. The number of significant places retained in the rounded-off value should be the same as that of the specified value in this Standard.

Indian Standard

BICYCLES — PEDAL ASSEMBLY — SPECIFICATION

(Third Revision)

1 SCOPE

This standard prescribes the requirements for pedal assembly suitable for fitting in bicycles for general use.

2 REFERENCES

The standards listed in [Annex A](#) contain provisions, which through reference in this text, constitute provisions of this standard. At the time of publication, the editions indicated were valid. All standards are subject to revision and parties to agreements based on this standard are encouraged to investigate the possibility of applying the most recent edition of these standards.

3 MATERIALS

3.1 The components of the pedal assembly may be made from any suitable material subject to its conformity with tests specified in this standard. The commonly used materials for spindle or axle are steel, Cr-Mo steel. Stainless steel and titanium alloy are the commonly used materials for body. For platform the commonly used materials are stainless steel, aluminium alloy, forged alloy, composites or synthetic plastic, and rubber.

3.2 Components of the pedal assembly which are subjected to friction such as ball races and spindle

shall have a minimum hardness of 600 HV (with 5 kgf load) on the wearing surfaces.

3.3 Balls, if made of steel, shall conform to Grade 105Cr5 of IS 1570 (Part 4) or Grade 103Cr4 of IS 4398. The finished balls shall conform to Grade 200 of IS 2898 (Part 1). These shall be heat treated to achieve hardness between 708 HV to 890 HV (with 5 kgf load). These shall be spherical and uniform in size.

The manufacturers may use any other suitable material for balls subject to their conformity with tests specified in this standard.

3.4 If ceramic balls are used, they shall conform to the grade Si_3N_4 (silicon nitride) or its equivalent. The finished balls shall conform to Grade 5 of IS 2898 (Part 2). These shall be heat treated (hot isostatic pressed) to achieve hardness between 78 HRC to 83 HRC (with 150 kgf load). These shall be spherical and uniform in size.

4 SHAPES AND DIMENSIONS

4.1 The pedal spindle shall conform to the dimensions given in [Fig. 1](#), [Fig. 2](#) and [Table 1](#). Other components shall be made to suit the spindle size (see [Fig. 3](#), [Fig. 4](#) and [Fig. 5](#)).

4.2 Some common shapes of pedal are given in [Fig. 3](#), [Fig. 4](#) and [Fig. 5](#).

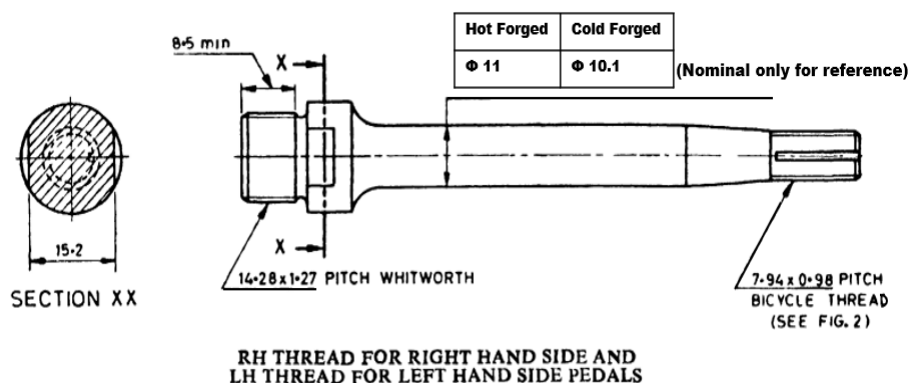

NOTE — The left hand side pedals shall either be stamped LH or suitably knurled to indicate LH thread.

All dimensions in millimetres.

FIG. 1 PEDAL SPINDLE

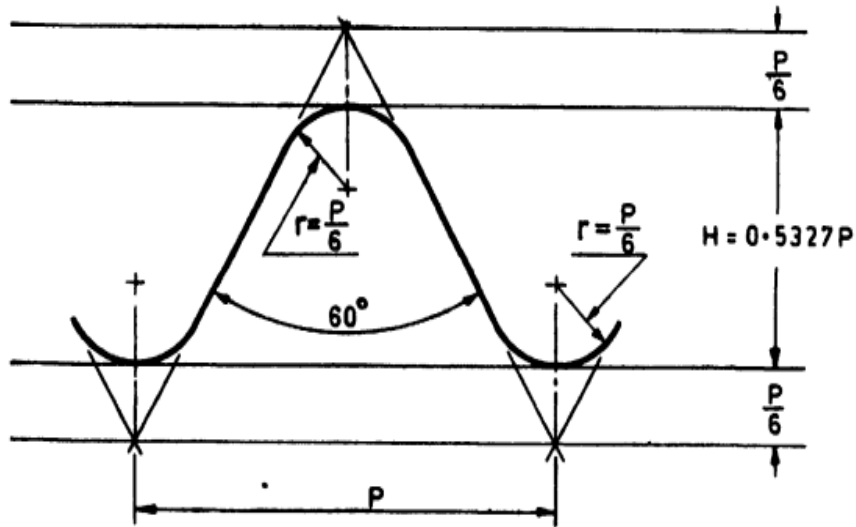

FIG. 2 FORM OF THREAD

Table 1 Dimensions of Form Thread

(Clause 4.1)

All dimensions in millimetres.

Sl No.	Size	Pitch P	External Thread						Internal Thread				
			Major Diameter		Effective Diameter		Minor Diameter		Major Diameter	Effective Diameter		Minor Diameter	
			Max	Min	Max	Min	Max	Min	Min	Max	Min	Max	Min
(1)	(2)	(3)	(4)	(5)	(6)	(7)	(8)	(9)	(10)	(11)	(12)	(13)	(14)
i)	7.94 × 0.98	0.977	7.938	7.798	7.417	7.325	6.896	6.706	7.938	7.508	7.417	7.093	6.896

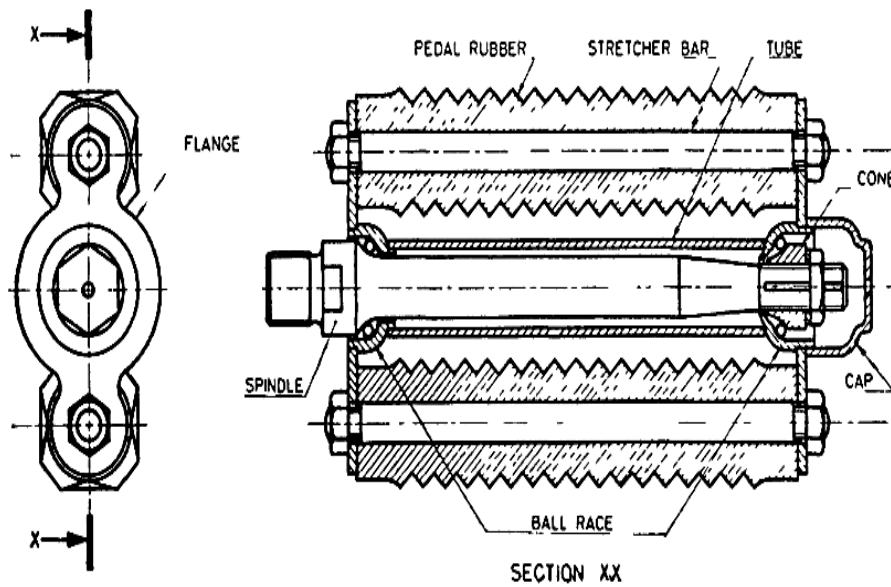
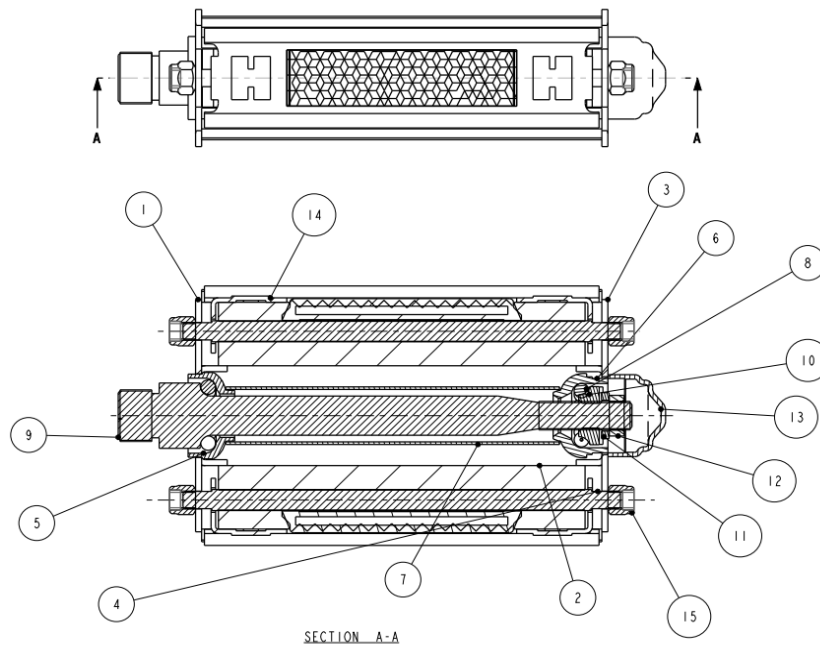
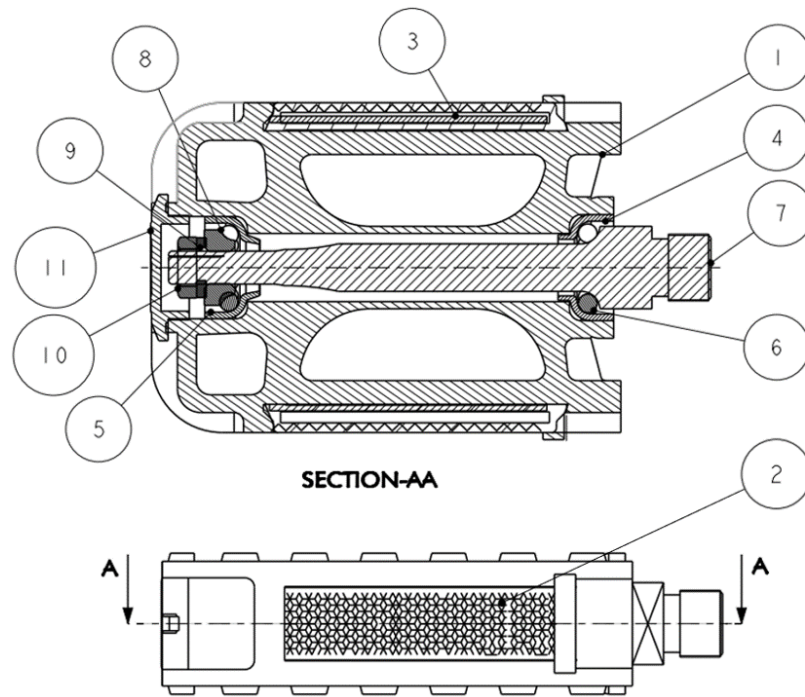

FIG. 3 BLOCK TYPE PEDAL ASSEMBLY (SCHEMATIC)

**Key**

No.	Name of Parts	No.	Name of Parts
1	Pedal plate crank end	9	Pedal axle
2	Pedal block	10	Pedal axle cone
3	Pedal plate cone end	11	Lock washer
4	Stretcher bar	12	Pedal axle nut
5	Crank end cup	13	Dust cover
6	Cone end cup	14	Block plate
7	Pedal pipe	15	HEX NYLOC nut M5 X 0.8P
8	Steel ball		

FIG. 4 RAT-TRAP/HEAVY DUTY TYPE PEDAL ASSEMBLY (SCHEMATIC)



Key

No.	Name of Parts	No.	Name of Parts
1	Pedal body	7	Pedal axle
2	Pedal reflector	8	Pedal axle cone
3	Reflector strip	9	Lock washer
4	Crank end cup	10	Pedal axle nut
5	Cone end cup	11	Pedal cap
6	Steel ball		

FIG. 5 INTEGRAL TYPE PEDAL ASSEMBLY (SCHEMATIC)

5 MANUFACTURE

Pedal shall be fitted to the spindle for free rotations. The pedal spindle assembly shall be then connected to the crank arm through threads for transferring the motion or power to the chain wheel. The threads shall be so formed as to facilitate easy fitting and replacement. The pedal spindle shall have a right-handed crank fitting thread if it is a right pedal spindle and a left-handed crank fitting thread if it is a left pedal spindle. The pedal shall bear a marking of 'Right' or 'Left' accordingly. The reflector attached to the pedal body shall conform to IS/ISO 6742-2.

6 FINISH

6.1 The spindles may preferably be chemically coloured or plated.

6.2 The tubes, flanges, stretcher bars and caps, if made of steel shall be finished smooth and shall be enamelled or nickel-chrome plated to service grade no. 1 [classification code Fe/(s Ni) 10b (Cr r)] of

IS 1068 or cadmium plated to service condition no. 2 (classification no. Fe/Cd 8) of IS 1572 or zinc plated to service condition no. 2 (classification no. Fe/Zn 7.5) of IS 1573 and if made of aluminium alloys shall be finished smooth and shall be enamelled or nickel-chrome plated to service grade no. 1 [classification code Al/(s Ni) 10b (Cr r)] of IS 1068.

NOTE — In view of the shape of some of the components a uniform thickness of plating is not to be expected. Therefore, in order to ensure that the thickness of nickel plating at any point is not less than that specified, an appropriately higher plating thickness should be aimed at.

6.3 Finished surfaces without plating shall be given a suitable rustproof treatment unless the substrate material is corrosion resistant.

6.4 Exposed edges that could come into contact with the rider's hands, legs, etc, during normal riding or normal handling and normal maintenance shall not be sharp, for example, deburred, broken, rolled, or processed with comparable techniques.

7 TESTS

All strength tests involving any synthetic resin/plastic materials shall be pre-conditioned for two hours and tested at an ambient temperature of $23\text{ }^{\circ}\text{C} \pm 5\text{ }^{\circ}\text{C}$.

7.1 Static Load Test (Not Applicable to Young Children's Bicycles)

7.1.1 For 'Young adult bicycles'; 'City and Trekking'; 'Roadster'; 'SLR bicycles'; 'Mountain bicycles'; and 'Racing bicycles', the pedal shall pass the test as specified in **4.10.3** of IS 10613.,

7.1.2 For BMX bicycles, the pedal shall pass the test as specified in **4.14.3** of IS 19034.

7.1.3 For EPAC bicycles, the pedal shall pass the test as specified in **4.3.12.3**.

7.2 Dynamic Durability Test

7.2.1 For bicycles for young children, the pedal shall pass the test as specified in **4.12.4** of IS 15533.

7.2.2 For 'young adult bicycles'; 'city and trekking'; 'roadster'; 'SLR bicycles'; 'mountain bicycles'; and 'racing bicycles', the pedal shall pass the test as specified in **4.10.5** of IS 10613.

7.2.3 For BMX bicycles, the pedal shall pass the test as specified in **4.14.4** of IS 19034.

7.2.4 For EPAC bicycles, the pedal shall pass the test as specified in relevant Indian Standard on EPAC bicycles.

7.3 Impact Test

7.3.1 Impact Test on Pedal

7.3.1.1 For bicycles for young children, the pedal shall pass the test as specified in **4.12.3** of IS 19034.

7.3.1.2 For 'Young adult bicycles', 'City and Trekking', 'Roadster', 'SLR bicycles', 'Mountain bicycles', and 'Racing bicycles', the pedal shall pass the test as specified in **4.10.4** of IS 10613.

7.3.1.3 For BMX bicycles, the crank/pedal assembly shall pass the test as specified in **4.14.5.1** of IS 19034

7.3.1.4 For EPAC bicycles, the pedal shall pass the test as specified in relevant Indian Standard on EPAC bicycles.

7.3.2 Impact Test on Plastic (Synthetic Resin) Pedal (Only Applicable to BMX Bicycles)

For BMX bicycles, the plastic pedal shall pass the test as specified in **4.14.5.2** of IS 15533.

7.3.3 Toxicity Test

7.3.3.1 For bicycles for young children, the pedal shall pass the test as specified in National Annex A of IS 19034.

7.3.3.2 For 'young adult bicycles'; 'city and trekking'; 'roadster'; 'SLR bicycles'; 'mountain bicycles'; and 'racing bicycles', the pedal shall pass the test as specified in **4.1.2** of IS 10613.

7.3.3.3 For BMX bicycles, the crank/pedal assembly shall pass the test as specified in **4.20** of IS 19034.

7.3.3.4 For EPAC bicycles, the pedal shall pass the test as specified in relevant Indian Standard on EPAC bicycles.

8 MARKING

8.1 The pedal assembly shall be marked indicating the source of manufacture and/or trademark. The pedal assembly shall carry suitable identification mark for left hand threads as indicated in [Fig. 1](#).

8.2 BIS Certification Marking

The product(s) conforming to the requirements of this standard may be certified as per the conformity assessment schemes under the provisions of the *Bureau of Indian Standards Act, 2016* and the Rules and Regulations framed thereunder, and the products may be marked with the Standard Mark.

ANNEX A

(Clause 2)

LIST OF REFERRED STANDARDS

<i>IS No./Other Standards</i>	<i>Title</i>	<i>IS No./Other Standards</i>	<i>Title</i>
IS 1068 : 1993	Electroplated coatings of nickel plus chromium and copper plus nickel plus chromium — Specification (<i>third revision</i>)	IS 4398 : 1994	Carbon-Chromium steel for the manufacture of balls, rollers and bearing races — Specification (<i>second revision</i>)
IS 1570-4 : 1988	Schedules for wrought steels: Part 4 Alloy steels (alloy constructional and spring steels) with specified chemical composition and mechanical properties (<i>first revision</i>)	IS 10613 : 2023	Cycles — Safety and performance requirements for bicycles (<i>third revision</i>)
IS 1572 : 1986	Electroplated coatings of cadmium on iron and steel (<i>second revision</i>)	IS 15533 : 2018/ ISO 8098 : 2014	Cycles — Safety requirements for bicycles for young children (<i>second revision</i>)
IS 1573 : 1986	Electroplated coating of zinc on iron and steel (<i>second revision</i>)	IS 19034 : 2024	BMX bicycles — Safety requirements and test methods
IS 2898 (Part 1) : 2019/ISO 3290-1 : 2014	Rolling bearings — Balls: Part 1 Steel balls (<i>second revision</i>)	ISO 6742-2 : 2023	Cycles — Lighting and retro-reflective device — Part 2: Retro-reflective device

To access Indian Standards click on the link below:

https://www.services.bis.gov.in/php/BIS_2.0/bisconnect/knowyourstandards/Indian_standards/isdetails/

ANNEX B

(Foreword)

COMMITTEE COMPOSITION

Bicycles Sectional Committee, TED 16

<i>Organization</i>	<i>Representative(s)</i>
Research and Development Centre for Bicycle and Sewing Machine, Ludhiana	SHRI RAKESH PATHAK (<i>Chairperson</i>)
All India cycle Manufacturers Association, New Delhi	DR K. B. B. THAKUR SHRI ZOHEB KHAN (<i>Alternate</i>)
Amar Wheels Private Limited, Ludhiana	SHRI KARAN AGGARWAL
Avon Cycles Limited, New Delhi	SHRI ONKAR SINGH PAHWA SHRI RAJWINDER SINGH (<i>Alternate</i>)
Central Tool Room, Ludhiana	SHRI ONKAR SINGH PAHWA (<i>Alternate</i>)
Citizen Press Components, Ludhiana	SHRI MANJINDER SINGH SHRI AMIT PRAKASH SHARMA (<i>Alternate</i>)
Controllerate of Quality Assurance, New Delhi	SHRI SUBIR ROYCHOWDHURI SHRI ASOKA KUMAR MN (<i>Alternate</i>)
Department of Industries of Commerce, Chandigarh	SHRI SHASHI KANT SHRI AJAY KUMAR (<i>Alternate</i>)
G-13 Bicycle Forum, Delhi	UMESH KUMAR NARANG SHRI RAJINDER JINDAL (<i>Alternate</i>)
Hero Cycles, Ludhiana	SHRI S. K. RAI SHRI K. C. SHARVA (<i>Alternate</i>)
Hero Ecotech Limited, Ludhiana	GURDEEP SINGH SHRI SURINDER PAL (<i>Alternate</i>)
Institute for Auto Parts and Hand tools Technology, Ludhiana	DR SANJEEV KATOCH
Lucky Exports, Ludhiana	SHRI SOHRAB CHHABRA SHRI HARSIMER JIT SINGH (<i>Alternate</i>)
Metro Tyres Limited, Ludhiana	SHRI JAGDEEP KUMAR SABLOK SHRI SAMIR MAYRA (<i>Alternate</i>)
National Institute of Technology, Jalandhar	DR RAMAN BEDI
Research & Development Centre For Bicycle and Sewing Machines, Ludhiana	SHRI VISHWAS MEHTA
Research and Development Centre for Bicycle and Sewing Machine, Ludhiana	SHRI RAJEEV SHARMA
S.K. Bikes Private Limited, Ludhiana	SHRI MUKESH KUMAR SHRI SACHIN LAKRA (<i>Alternate</i>)

IS 628 : 2024

<i>Organization</i>	<i>Representative(s)</i>
Sebco Enterprises, Ludhiana	SHRI RAJEEV JAIN SHRI LALIT SHARMA (<i>Alternate</i>)
Spark Engineering Private Limited, Ghaziabad	SHRI ANOOP AGGARWAL SHRI PRADEEP KUMAR AGGARWAL (<i>Alternate</i>)
Tube Investments of India Limited, Chennai	SHRI PRAKASH V. SHRI VENKATESWARAN B. (<i>Alternate</i>)
United Cycle and Parts Manufacturers Association, Punjab 	PRESIDENT GENERAL SECRETARY (<i>Alternate</i>)
Vishal Cycles Private Limited, Ludhiana	SHRI SANJEEV MAHINDRU SHRI BHIM SAIN (<i>Alternate</i>)
BIS Directorate General	SHRI DEEPAK AGGARWAL, SCIENTIST 'F' AND HEAD (TRANSPORT ENGINEERING)[REPRESENTING DIRECTOR GENERAL (<i>Ex-officio</i>)]

Member Secretary
SHRI RAVINDRA BENIWAL
SCIENTIST 'C'/DEPUTY DIRECTOR
(TRANSPORT ENGINEERING), BIS

Bureau of Indian Standards

BIS is a statutory institution established under the *Bureau of Indian Standards Act, 2016* to promote harmonious development of the activities of standardization, marking and quality certification of goods and attending to connected matters in the country.

Copyright

BIS has the copyright of all its publications. No part of these publications may be reproduced in any form without the prior permission in writing of BIS. This does not preclude the free use, in the course of implementing the standard, of necessary details, such as symbols and sizes, type or grade designations. Enquiries relating to copyright be addressed to the Head (Publication & Sales), BIS.

Review of Indian Standards

Amendments are issued to standards as the need arises on the basis of comments. Standards are also reviewed periodically; a standard along with amendments is reaffirmed when such review indicates that no changes are needed; if the review indicates that changes are needed, it is taken up for revision. Users of Indian Standards should ascertain that they are in possession of the latest amendments or edition by referring to the website-www.bis.gov.in or www.standardsbis.in.

This Indian Standard has been developed from Doc No.: TED 16 (24369).

Amendments Issued Since Publication

Amend No.	Date of Issue	Text Affected

BUREAU OF INDIAN STANDARDS

Headquarters:

Manak Bhavan, 9 Bahadur Shah Zafar Marg, New Delhi 110002

Telephones: 2323 0131, 2323 3375, 2323 9402

Website: www.bis.gov.in

Regional Offices:

	Telephones
Central : 601/A, Konnectus Tower -1, 6 th Floor, DMRC Building, Bhavbhuti Marg, New Delhi 110002	{ 2323 7617
Eastern : 8 th Floor, Plot No 7/7 & 7/8, CP Block, Sector V, Salt Lake, Kolkata, West Bengal 700091	{ 2367 0012 2320 9474
Northern : Plot No. 4-A, Sector 27-B, Madhya Marg, Chandigarh 160019	{ 265 9930
Southern : C.I.T. Campus, IV Cross Road, Taramani, Chennai 600113	{ 2254 1442 2254 1216
Western : Manakalya, 4 th Floor, NTH Complex (W Sector), F-10, MIDC, Andheri (East), Mumbai 400093	{ 283 25838

Branches : AHMEDABAD, BENGALURU, BHOPAL, BHUBANESHWAR, CHANDIGARH, CHENNAI, COIMBATORE, DEHRADUN, DELHI, FARIDABAD, GHAZIABAD, GUWAHATI, HARYANA (CHANDIGARH), HUBLI, HYDERABAD, JAIPUR, JAMMU, JAMSHEDPUR, KOCHI, KOLKATA, LUCKNOW, MADURAI, MUMBAI, NAGPUR, NOIDA, PARWANOO, PATNA, PUNE, RAIPUR, RAJKOT, SURAT, VIJAYAWADA.