

---

---

अंतरिक्ष प्रणालियाँ — ग्राउंड सिस्टम, ग्राउंड  
सपोर्ट उपकरण और पेलोड के साथ लॉन्च वाहन  
के बीच अंतरापृष्ठ नियंत्रण प्रलेख

Space Systems — Interface Control  
Documents Between Ground  
Systems, Ground Support  
Equipment and Launch Vehicle with  
Payload

ICS 49.140

© BIS 2024

© ISO 2023



भारतीय मानक ब्यूरो  
BUREAU OF INDIAN STANDARDS  
मानक भवन, 9 बहादुर शाह जफर मार्ग, नई दिल्ली - 110002  
MANAK BHAVAN, 9 BAHADUR SHAH ZAFAR MARG  
NEW DELHI - 110002  
[www.bis.gov.in](http://www.bis.gov.in) [www.standardsbis.in](http://www.standardsbis.in)

## NATIONAL FOREWORD

This Indian Standard which is identical with ISO 17689 : 2023 'Space systems — Interface control documents between ground systems, ground support equipment and launch vehicle with payload' issued by International Organization for Standardization (ISO), was adopted by the Bureau of Indian Standards on the recommendations of Air and Space Vehicles Sectional Committee and approval of the Transport Engineering Division Council.

The text of ISO standard has been approved as suitable for publication as an Indian Standard without deviations. Certain terminologies and conventions are, however, not identical to those used in Indian Standards. Attention is particularly drawn to the following:

- a) Wherever the words 'International Standard' appear referring to this standard, they should be read as 'Indian Standard'; and
- b) Comma (,) has been used as a decimal marker, while in Indian Standards, the current practice is to use a point (.) as the decimal marker.

Attention is drawn to the possibility that some of the elements of this standard may be the subject of patent rights. The Bureau of Indian Standards shall not be held responsible for identifying any or all such patent rights.

For the purpose of deciding whether a particular requirement of this standard is complied with, the final value, observed or calculated, expressing the result of a test or analysis, shall be rounded off in accordance with IS 2 : 2022 'Rules for rounding off numerical values (*second revision*)'. The number of significant places retained in the rounded off value should be the same as that of the specified value in this standard.

# Contents

Page

<b>Introduction</b> .....	<b>iv</b>
<b>1 Scope</b> .....	<b>1</b>
<b>2 Normative references</b> .....	<b>1</b>
<b>3 Terms and definitions</b> .....	<b>1</b>
<b>4 General</b> .....	<b>3</b>
<b>5 Requirements to ICD execution</b> .....	<b>6</b>
5.1 Requirements to item ICD execution .....	6
5.2 Requirements to execution of summary list of launch site ICD .....	12
<b>6 ICD development, validation and verification stages</b> .....	<b>13</b>
6.1 Working stages .....	13
6.2 Verification and validation procedures .....	15
<b>Bibliography</b> .....	<b>16</b>

## Introduction

This document is intended for application at realization of interstate, intergovernmental or non-governmental space activities, between operators of different countries and organizations on the basis of their space activity contracts.

Interfaced (connected) devices development by two and more designers (commands, organizations, developers of other specializations, etc.) creates a need for coordination between them to prevent interfaces incompatibility, taking into account unlimited possibilities for design (structure) improvement in the course of space systems development.

Interface control documents (ICDs) make it possible to systematically create (develop), operate and manage interfaces (see [Clause 1](#)) at all stages of the life cycle of a launch system. They are necessary in order to ensure the normal functioning of a launch system, prevent accidents and reduce acceptable risks when implementing joint space projects and providing spacecraft launch services. ICD between payload and a launch vehicle is defined in ISO 15863.

Application of this document at design and development stages improves control and compatibility of interfaces (see [Clause 1](#)).

Application of this document at operation stage improves a launch system safety and facilitates control of interfaces.

Interface control documents format defined in this document does not contain the descriptions regarding various properties of ground support equipment (i.e. performance, functions or endurance to launch mechanical environment or quality assurance provisions), which are defined in technical specifications.

Control of interfaces, independently of its frequency or depth, cannot replace stages of parameters definition of high-quality production and development of technical requirements of project, design and development. Interfaces control is used as a control process that can provide necessary verification of successful finishing of design at a stated in contract period.

*Indian Standard*

SPACE SYSTEMS — INTERFACE CONTROL DOCUMENTS  
BETWEEN GROUND SYSTEMS, GROUND  
SUPPORT EQUIPMENT AND LAUNCH VEHICLE WITH  
PAYLOAD

## 1 Scope

This document establishes basic requirements for interface control documents (ICD) writing and interface control procedures for the following items included in the launch system: payload, launch vehicle, ground support equipment (according to ISO 14625) and launch site (buildings with utility systems), specifically:

- a) ICD between the ground support equipment and the payload;
- b) ICD between the ground support equipment and the launch vehicle;
- c) ICD between items of the ground support equipment;
- d) ICD between the ground support equipment and the launch site.

This document is applicable to organizations developing ground support equipment and to operators performing space activity.

## 2 Normative references

There are no normative references in this document.

## 3 Terms and definitions

For the purposes of this document, the following terms and definitions apply.

ISO and IEC maintain terminology databases for use in standardization at the following addresses:

- ISO Online browsing platform: available at <https://www.iso.org/obp>
- IEC Electropedia: available at <https://www.electropedia.org/>

### 3.1

#### **acceptable risk**

safety risk, the severity and the probability of which can be reasonably accepted by humanity, without durable or irreversible foreseeable consequence on health, Earth, and the environment, at the present time and in the future

**EXAMPLE** A safety risk can be acceptable for crew members of a manned space vehicle when it is comparable to that of test pilots, for the personnel participating in hazardous activities when it is comparable to that of industrial workers, for people, public and private property, and the environment when it is comparable to that of other hazardous human activities (e.g. high-speed surface travel).

### 3.2

#### **accident**

undesired event arising from operation of any project-specific items which results in:

- a) human death or injury;
- b) loss of, or damage to, project hardware, software or facilities that can then affect the accomplishment of the mission;

- c) loss of, or damage to, public or private property; or
- d) detrimental effects on the environment

[SOURCE: ISO 14620-1:2018, 3.1.1, modified — "and" has been changed to "or" at the end of item c); note 1 to entry has been removed.]

### 3.3 ground support equipment

non-flight systems, equipment or devices necessary to support the operations of transporting, receiving, handling, assembly, inspection, test, checkout, servicing, launch and recovery of a space system at launch, landing or retrieval sites

[SOURCE: ISO 14625:2023, 3.1.5, modified — The abbreviated term "GSE" has been removed.]

### 3.4 hazard

existing or potential condition that can result in an *accident* (3.2)

[SOURCE: ISO 14623:2003, 2.30]

### 3.5 ICD for ground support equipment

interface control document for ground support equipment  
document which describes mechanical, hydraulic, pneumatic, thermal, electric and other parameters of interfaces between the *ground support equipment* (3.3) and the *launch vehicle* (3.10), items of the ground support equipment, the ground support equipment and *launch site* (3.8) objects (building constructions with technical systems), and which is used to control these parameters

### 3.6 interfaces controller

specialist in the scope of *launch complexes* (3.7) or organization of space activity which controls interface control document (ICD) observance by organization-executor at realization of contract of space technics creation

Note 1 to entry: Interfaces controllers may be indicated in the contract between the space technics leading developers and executors. The leading developer can let a contract with the interfaces controller.

### 3.7 launch complex

site assigned to or owned by a *launch vehicle* (3.10) operator to operate a launch vehicle

[SOURCE: ISO 14620-2:2019, 3.9]

### 3.8 launch site

site necessary for the prelaunch and launch operations of a space vehicle and for the in-flight operations during the launch phase

[SOURCE: ISO 14620-2:2019, 3.11]

### 3.9 launch system

system made up of a *launch vehicle* (3.10), the associated *launch complex* (3.7), *launch site* (3.8), *payload* (3.11), *ground support equipment* (3.3) and associated airborne equipment (including software), control systems, navigation system, trajectories, procedures, necessary personnel, and any other associated items

[SOURCE: ISO 14620-2:2019, 3.13]

### 3.10

#### **launch vehicle**

vehicle designed to transport *payloads* (3.11) to space

[SOURCE: EN 16601-00-01:2015, 2.3.127]

### 3.11

#### **payload**

set of space segment elements (parts of a space system, placed in space, to fulfil the space mission objectives)

Note 1 to entry: A spacecraft payload is a set of instruments or equipment that performs the user mission.

Note 2 to entry: A launcher payload is a set of space segment elements carried into space in accordance with agreed position, time and environmental conditions.

[SOURCE: ISO 10795:2019, 3.165, modified — The abbreviated term "P/L" has been removed.]

## 4 General

**4.1** An ICD for ground support equipment is developed as a separate document for each part included in the launch system: payload, launch vehicle, items of ground support equipment, launch site (building constructions with technical systems):

- a) ICD between the ground support equipment and the payload;
- b) ICD between the ground support equipment and the launch vehicle;
- c) ICD between items of the ground support equipment;
- d) ICD between the ground support equipment and the launch site.

The leading enterprise-developer of the ground support equipment is responsible for the development of a list of ICD for this equipment.

The leading enterprise-developer of a launch site supervises types, quantity, and location of interfaces of ground support equipment items, which are developed by the enterprises according to ICD for the items.

The developers of components of a launch site develop ICD and coordinate them with other enterprises, which are developers of the interface elements.

**4.2** When a joint project is implemented by several participants, it is an enterprise, which owns a finished (existing) part or an element of a system, that has an advantage in making a decision about interface structures over participants, which have yet to develop an interface part of a system.

The organization, which provides spacecraft launch services, gives the full information about interfaces of the launch pad to the customer.

An organization, which is responsible for the payload, shall provide the interface status information to the operator.

**4.3** The technical specification shall include a record that ICD for an element is available.

Each interface shall have the code, which contains the main information about it.

EXAMPLE 1 ICD XXXX-YYYY-000-AAA – interface code, where:

- XXXX is the source item code;
- YYYY is the consumer item code;

- 000 is the interface number;
- AAA is the code of place where the interface is located.

The interface number is followed by a reference number or code (in brackets), which may indicate the drawing (sheet) where this interface is demonstrated.

EXAMPLE 2 A110-B010-001-005 (A110.08.03.01).

The number of symbols and use of figures and letters in the index should correspond to approved codes in technical specifications.

**4.4** ICD may be presented as a text, a picture (drawing), or as a combination (a text and a picture).

A special indicator, like the letter “G”, may be added to the picture (drawing) code (e.g. ICD XXXX-YYYY-000-AAA-G).

The internal ICD is developed when there are many interfaces between elements of the ground support equipment, which need to be controlled.

For simple search, items of the ground support equipment, to which the interface belongs, may be indicated.

**4.5** The procedure of ICD preparation is as follows.

Launch site developers shall initiate the process of ICD preparation. The general requirements for an ICD are as follows:

- the ICD provides distribution of work and responsibility between developers;
- the ICD has a hierarchical structure (see [Figure 2](#));
- the ICD directs the control of works of developers during the creation of interfaces.

The scheme of division of the launch site's components is presented in [Figure 1](#). The responsible developers are defined for working out and handing over to codevelopers requirements to interfaces of launch system components.



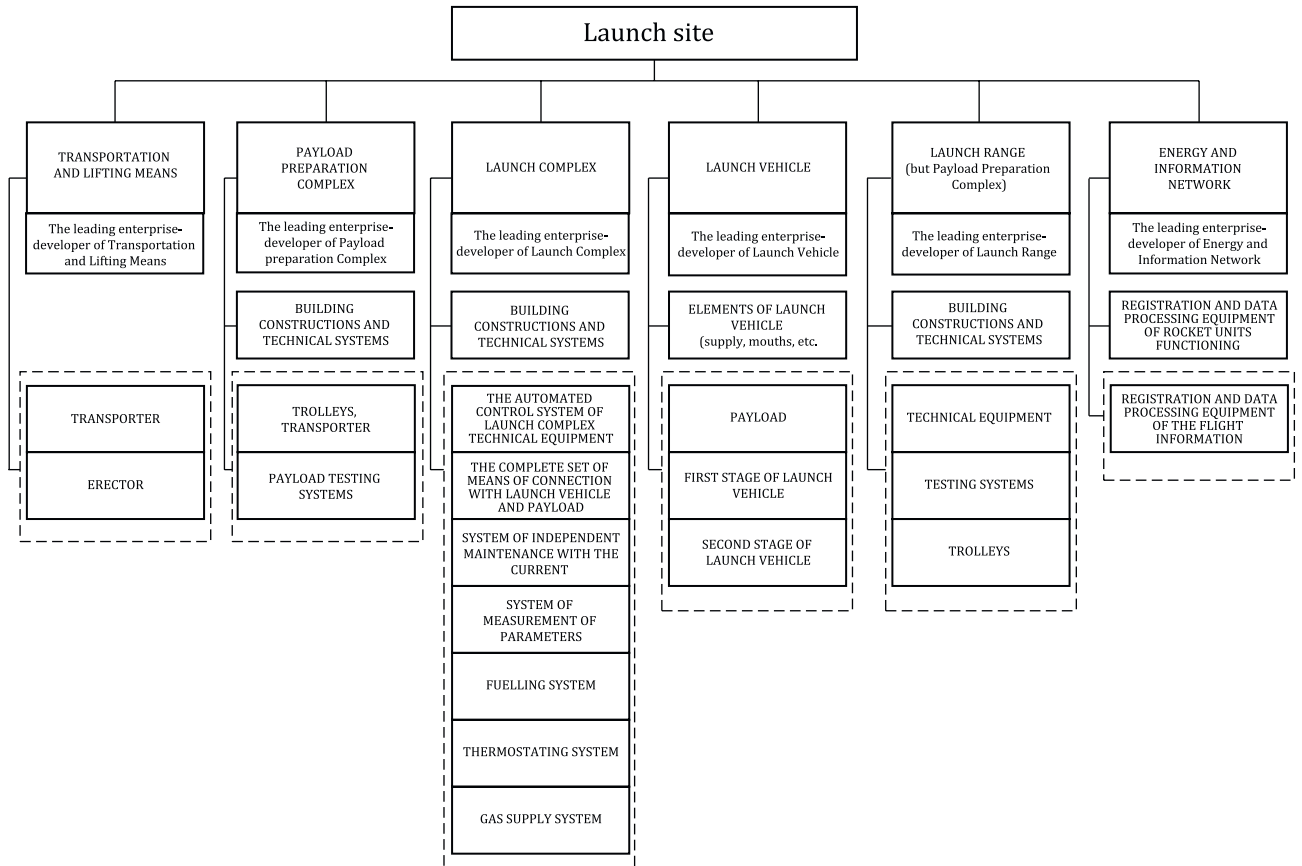
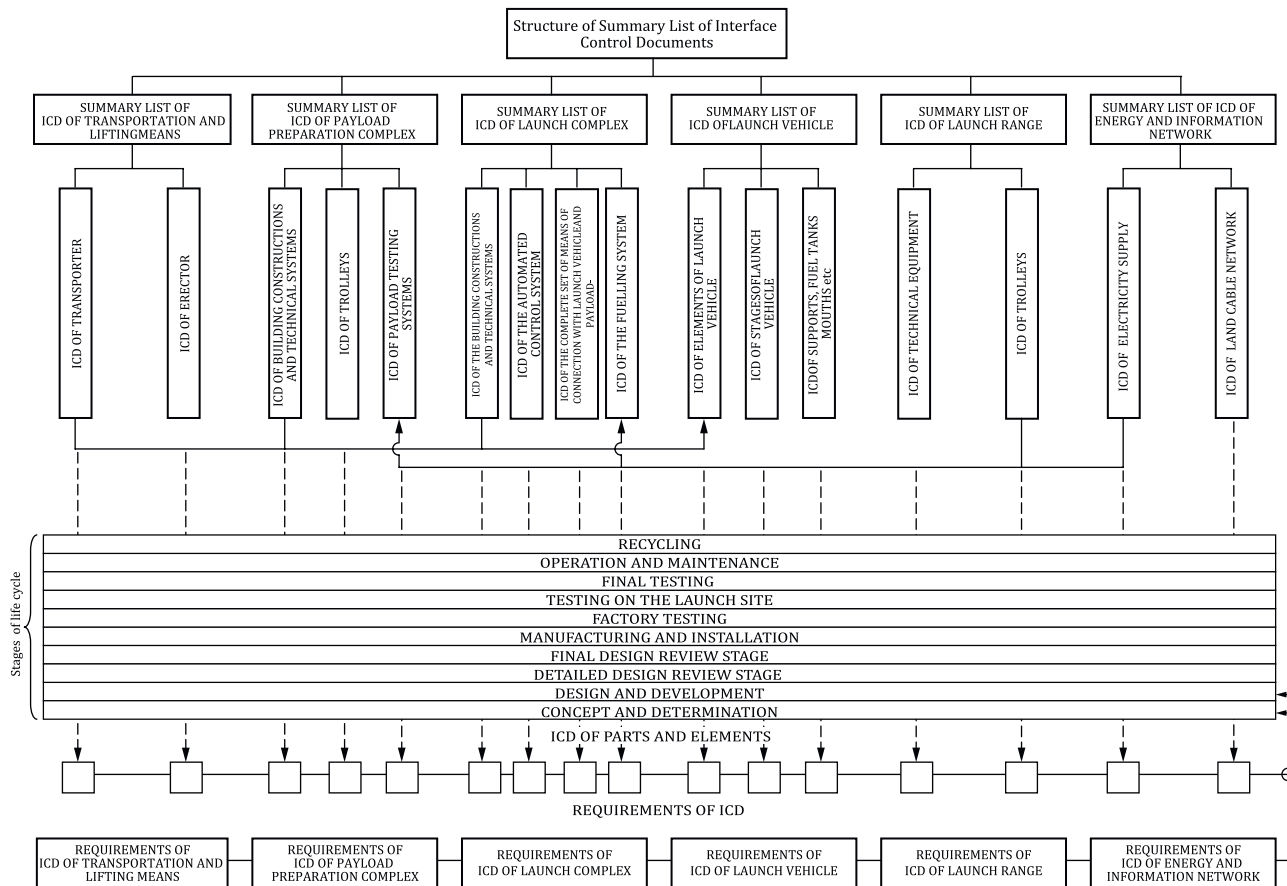

Figure 1 — Example structure of a launch site



**Figure 2 — Example structures of interface control documents of the launch site**

The leading developer of the components of the launch system hands over requirements to interfaces to the codevelopers of the components of a launch vehicle, to developers of the complexes of the launch system, and to developers of the components of the complexes.

Developers of the complexes and developers of the components of the complexes give proposals to leading developers of the launch system in the process of coordination of the requirements:

- about the specification of the requirements to interfaces;
- about ICD formats;
- about the interface development works breakdown;
- about ICD execution time schedule;
- about stages and duration of progress monitoring for interface implementation (development), etc.

Developers of the components make the launch system according to ICD and according to the approved requirements.

## 5 Requirements to ICD execution

### 5.1 Requirements to item ICD execution

#### 5.1.1 ICD should include the following:

- cover sheet;

- revision record;
- applicability;
- description of the interface;
- verification requirements.

**5.1.2** The cover sheet of ICD should contain the following items:

- ICD title;
- ICD designation.

An ICD formal reference number shall identify a document and may comprise several blocks of numbers and letters.

This reference number comprises six blocks, which include letters/numbers, separated by hyphens.

Block 1 identifies a project.

Block 2 identifies a document type (in this case, ICD).

Block 3 identifies a document according to a product tree (or according to a tree of elements, if applied to an interface).

Block 4 defines differences between documents of the same type, which, however, correspond to different versions of the same item.

Block 5 consists of one or several numbers, which correspond to the index number of a particular document. These numbers define the type of a document, which is used for a single item in accordance with a component diagram. Digits of a reference number are determined by a party (participant), which has a document numbering system of its own.

Block 6 consists of two to four letters which identify an entity, which issues a document.

Project parties may use other variants of ICD reference, which provide reliable identification of a document:

- issue date;
- organization, which issues a document.

**5.1.3** The revision record should contain the following description:

- revision number;
- revision date;
- summary of revision contents;
- approval.

**5.1.4** The applicability record should contain the following information:

- applicable documents;
- definitions;
- units of measurement.

5.1.5 The description of an interface should specify the title and number of units, associated with interfaces, types of interfaces (mechanical, electric, pneumatic, hydraulic, thermal, electromagnetic, radiofrequency, etc.), location (coordinates), parameters, identification of hazards, and description of the interface structure.

Information about an interface should be stated clearly and unambiguously.

Information should be arranged in tables, with interface breakdown by type. Interface parameters, included in tables, are defined by the developer based on the need to provide maximum of information about the interface.

EXAMPLE See [Tables 1](#) and [2](#).

**Table 1 — Pneumatic interfaces of gas-supply system A110**

Interface reference number	Working medium	Location	Parameters			Interface drawing number
			$P$ , MPa	$T$ , °C	$Q$ , m <sup>3</sup> /c	
A110-B010-001	Liquid nitrogen (LIN)	Room 10	20,0 ±1	25,0 ±5	0,04 ±0,01	A110-B010-001-G

**Table 2 — Electric interfaces of gas-supply system A110**

Interface number	Current type	Location	Parameters			Interface drawing number
			$I$ (A)	$U$ (M)	$R$ (Ω)	
A110-E020-001	AC\DC	Build 2 room 5	1 to 1,5	12 ± 1	≤0,005	A110-E020-001-G

The table should include all the ranges of parameter values, registered when performing setup, tests and operations. In case of value deviations, conditions should be noted, which correspond to a particular parameter value.

For more information, it is necessary to provide pictures (drawings) of premises, indicating the interface location and coordinates, and pictures (drawings) of the interface structure, which may be included in ICD or may be registered separately as an annex.

Examples of interface drawing formats are shown in [Figures 3](#) to [6](#).

Examples of interfaces location between a launch vehicle, ground support equipment and a launch site (building structures with utility systems) are shown in [Figure 7](#).

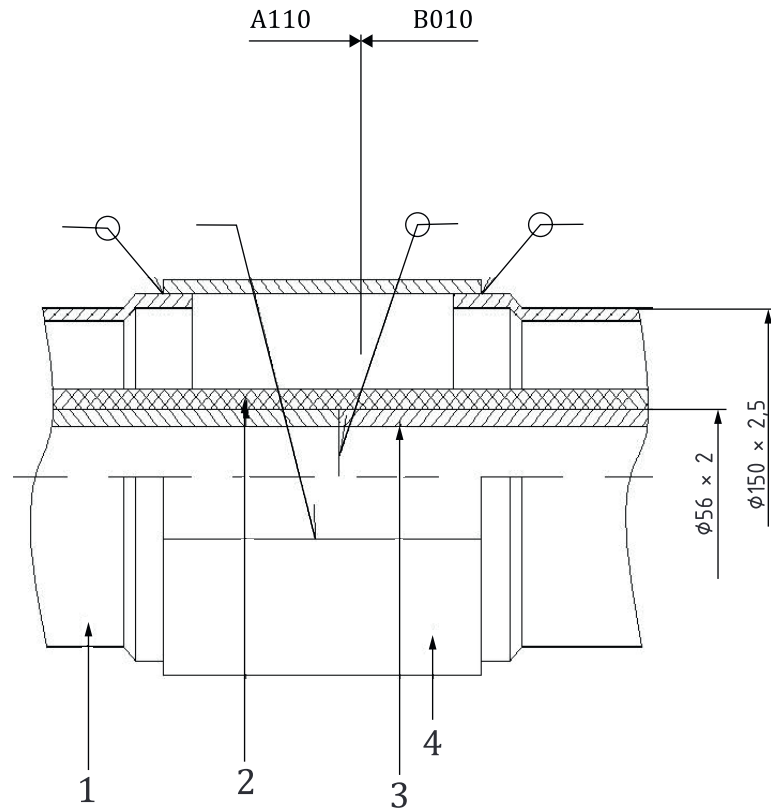

**Key**

- 1 case
- 2 insulation
- 3 inner pipe
- 4 half-coupling

**Figure 3 — Interface A110-B010-001 (A110.08.03.01)**

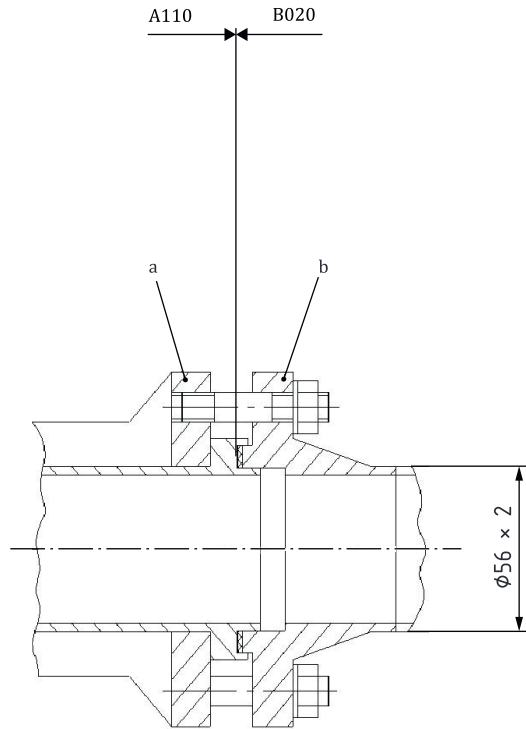

- a Flange "O" of control system 1.
- b Flange of liquid oxygen filling system.

**Figure 4 — Interface A110-B020-002 (A110.08.04.01)**

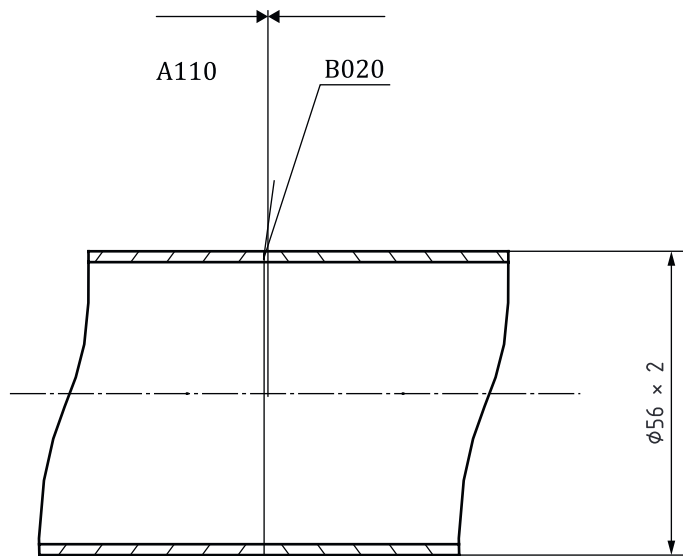

**Figure 5 — Interface A110-B020-005 (A110.08.05.01)**

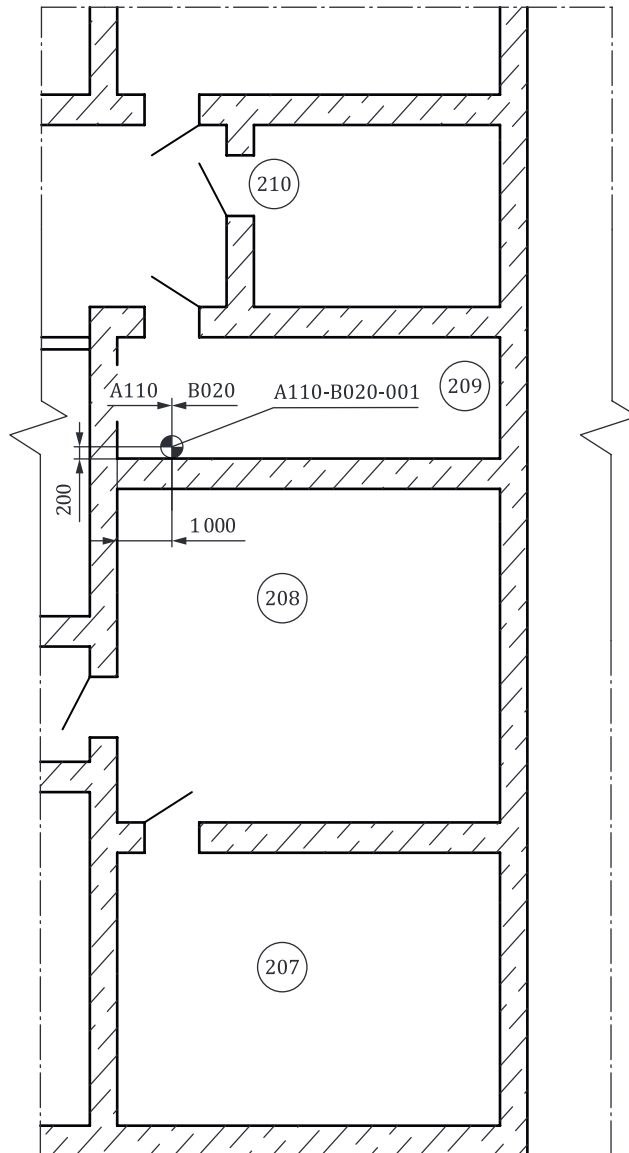
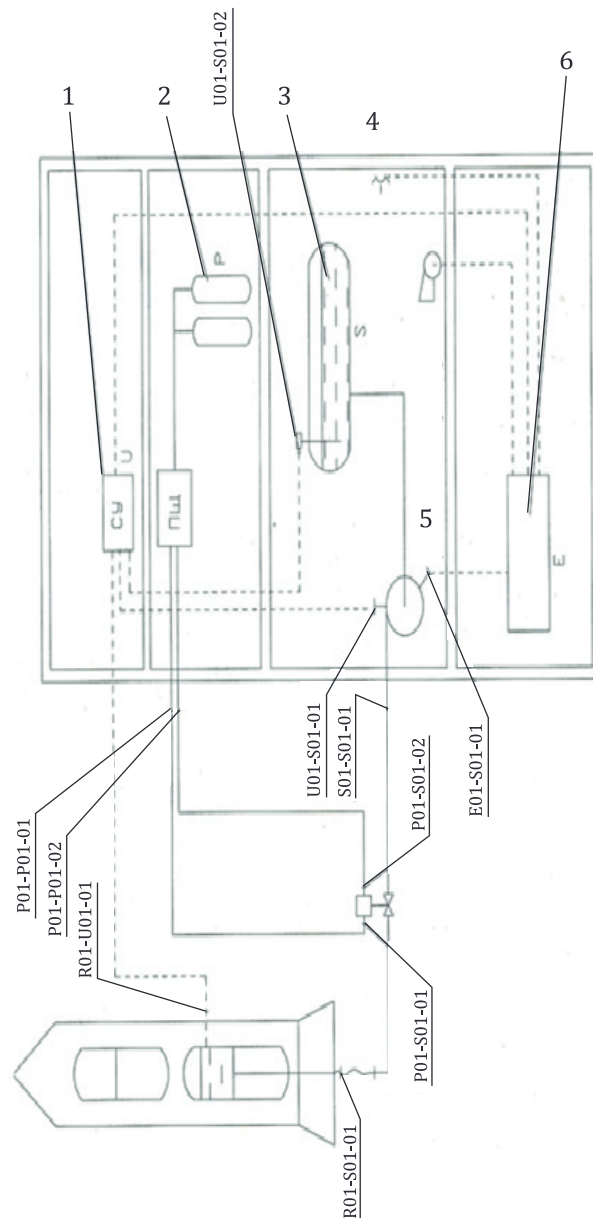

Figure 6 — Interface coordinates A110-B020-001 (A110.08.03.01)



**Key**

- |   |   |
|---|---|
| 1 control system (support equipment)    | 4 lighting (utility system)               |
| 2 gas supply system (support equipment) | 5 ventilation (utility system)            |
| 3 refuelling system (support equipment) | 6 power supply system (support equipment) |

**Figure 7 — Examples of interfaces arrangement between a launch vehicle, facilities of a launch site, and elements of ground support equipment**

Information about interfaces may be provided in the format that is most suitable for organizations, but it has to be unified for the entire project and it must be applied by all the participants. The format, which is used to provide information about interfaces, has to be approved at the concept and definition stages during preliminary design review (PDR).

**5.2 Requirements to execution of summary list of launch site ICD**

**5.2.1** A summary list of launch site ICD is developed based on ICD for ground support equipment items, launch vehicle ICD and other ICDs.



**5.2.2** A summary list of ICD is provided in a table. All launch site facilities, ground support equipment items and launch vehicle are listed in rows and columns of this table.

EXAMPLE See [Table 3](#).

**Table 3 — Summary list of launch site ICD**

	LV	FS	OFS	GSS	TCS	CS	TE
Launch vehicle (LV)	x	R010-A110-001					
Fuelling system (FS)	A110-R010-001	x	No	A110-B020-001			
Oxidant filling system (OFS)		No	x				F002-G001-001
Gas supply system (GSS)		B020-A110-001		x			
Temperature control system (TCS)					x		
Control system (CS)						x	
Transporter erector (TE)			G001-F002-001				x

If there is an interface between elements, interface numbers are inserted in cells. If there is no interface, then “No” is inserted.

## 6 ICD development, validation and verification stages

### 6.1 Working stages

Development, verification and validation of interfaces for the launch vehicle, payload, launch site systems (building structures with utility systems), and for the ground support equipment should be provided by the organization-developer and the operator of space services, with participation of the interfaces controller, based on ICD of these objects.

These procedures, along with the project analysis, should be carried out according to the stages specified in IEC 61160.

EXAMPLE See [Table 4](#).

**Table 4 — ICD - interface conformity for stages of life cycle**

Stage of life cycle	Type of project analysis	Abbreviation	Period of life cycle stages analysis	Check of ICD - interface conformity
Concept and determination	Preliminary design review	PDR	<ul style="list-style-type: none"> <li>— At proposed requirements receiving</li> <li>— At contract or order receiving</li> </ul>	Determination of interfaced units and preparation of ICD structure
Design and development	Detailed design review	DDR	<ul style="list-style-type: none"> <li>— During design stage</li> <li>— After design stage</li> <li>— During development stage</li> </ul>	<ul style="list-style-type: none"> <li>— ICD writing</li> <li>— ICD improvement</li> <li>— Final ICD approval</li> </ul>
	Final design review	FDR	<ul style="list-style-type: none"> <li>— After manufacturing of pre-production models</li> <li>— After test of pre-production models</li> </ul>	Interface verification of ICD compliance

**Table 4 (continued)**

Stage of life cycle	Type of project analysis	Abbreviation	Period of life cycle stages analysis	Check of ICD - interface conformity
Manufacturing and installation	Manufacturing design review	MDR	<ul style="list-style-type: none"> <li>— During support process development</li> <li>— At finishing of support process development</li> <li>— After performance of initial product examples</li> <li>— After delivery of initial product examples to customer</li> </ul>	Interface verification of ICD compliance and check of interface units compliance
	Installation design review	IDR	<ul style="list-style-type: none"> <li>— After installation of initial product examples</li> <li>— After commissioning performance</li> </ul>	Interface validation
Operation and maintenance	Use design review	UDR	<ul style="list-style-type: none"> <li>— After beginning of operation and maintenance</li> <li>— After selected operation periods (for example, 1/2, 1, 5, 10 years)</li> </ul>	<ul style="list-style-type: none"> <li>— Check of interface condition during maintenance</li> <li>— Planned check of interface condition</li> </ul>

Initial data for ICD should be gathered after the operator and leading organization-developer have signed the contract for product creation at the design conception and determination (PDR) stage. It enables the authors to define the quantity of interfaced components, the types of interfaces between them and their formats.

The main stage of ICD development is the stage of design and development (DDR). All interfaces, types of interfaces (connections), operating environment, coordinates and other required characteristics are defined at this stage. The draft of ICD is analysed, specified and supplied by all participants of product creation with obligatory participation of the interfaces controller.

ICD is finalized during development of design documentation for prototype manufacturers. ICD is prepared to be verified at the final period of the design and development (DDR) stage. All interfaces (connections) of the launch vehicle, each object of the launch site, and ground support equipment items shall be completely defined and checked during the preparation for ICD verification.

An ICD prototype is verified by manufacturers at the stage of a prototype production.

Verification of ICD of pre-production model is performed by organization-manufacturers at the stage of pre-production model manufacturing.

Preparation for ICD validation is performed after prototype tests (FDR).

ICD correction and interfaces validation are performed after improvements of design (construction) based on test results of a prototype of the launch site object or ground support equipment item. Interfaces validation shall be performed before the production and installation (MDR) begins.

## **6.2 Verification and validation procedures**

All interface parameters described in ICD should be verified. Verification methods should be described in a separate clause of ICD. Measurement devices and methods shall be indicated. Interfaces are validated after prototype tests are performed. Validation results are provided in the report, which proves compliance of interfaces with the project and attached ICD. On completion of ICD development, the report is made, which is signed by a customer (operator), a project executive, and an ICD compliance supervisor.

## Bibliography

- [1] ISO 10795:2019, *Space systems — Programme management and quality — Vocabulary*
- [2] ISO 14620-1:2018, *Space systems — Safety requirements — Part 1: System safety*
- [3] ISO 14620-2:2019, *Space systems — Safety requirements — Part 2: Launch site operations*
- [4] ISO 14623:2003, *Space systems — Pressure vessels and pressurized structures — Design and operation*
- [5] ISO 14625:2023, *Space systems — Ground support equipment for use at launch, landing or retrieval sites — General requirements*
- [6] ISO 15863, *Space systems — Spacecraft-to-launch-vehicle interface control document*
- [7] IEC 61160, *Design review*
- [8] EN 16601-00-01:2015, *Space systems — Glossary of terms*



## Bureau of Indian Standards

BIS is a statutory institution established under the *Bureau of Indian Standards Act, 2016* to promote harmonious development of the activities of standardization, marking and quality certification of goods and attending to connected matters in the country.

### Copyright

BIS has the copyright of all its publications. No part of these publications may be reproduced in any form without the prior permission in writing of BIS. This does not preclude the free use, in the course of implementing the standard, of necessary details, such as symbols and sizes, type or grade designations. Enquiries relating to copyright be addressed to the Head (Publication & Sales), BIS.

### Review of Indian Standards

Amendments are issued to standards as the need arises on the basis of comments. Standards are also reviewed periodically; a standard along with amendments is reaffirmed when such review indicates that no changes are needed; if the review indicates that changes are needed, it is taken up for revision. Users of Indian Standards should ascertain that they are in possession of the latest amendments or edition by referring to the website-[www.bis.gov.in](http://www.bis.gov.in) or [www.standardsbis.in](http://www.standardsbis.in).

This Indian Standard has been developed from Doc No.: TED 14 (22951).

### Amendments Issued Since Publication

Amend No.	Date of Issue	Text Affected

## BUREAU OF INDIAN STANDARDS

### Headquarters:

Manak Bhavan, 9 Bahadur Shah Zafar Marg, New Delhi 110002

Telephones: 2323 0131, 2323 3375, 2323 9402

Website: [www.bis.gov.in](http://www.bis.gov.in)

### Regional Offices:

Central : 601/A, Konnectus Tower -1, 6<sup>th</sup> Floor,  
DMRC Building, Bhavbhuti Marg, New  
Delhi 110002

Telephones

{ 2323 7617

Eastern : 8<sup>th</sup> Floor, Plot No 7/7 & 7/8, CP Block, Sector V,  
Salt Lake, Kolkata, West Bengal 700091

{ 2367 0012  
2320 9474

Northern : Plot No. 4-A, Sector 27-B, Madhya Marg,  
Chandigarh 160019

{ 265 9930

Southern : C.I.T. Campus, IV Cross Road, Taramani, Chennai 600113

{ 2254 1442  
2254 1216

Western : Manakalya, 5<sup>th</sup> Floor/MTNL CETTM, Technology Street, Hiranandani Gardens, Powai  
Mumbai 400076

{ 25700030  
25702715

**Branches :** AHMEDABAD, BENGALURU, BHOPAL, BHUBANESHWAR, CHANDIGARH, CHENNAI, COIMBATORE, DEHRADUN, DELHI, FARIDABAD, GHAZIABAD, GUWAHATI, HARYANA (CHANDIGARH), HUBLI, HYDERABAD, JAIPUR, JAMMU, JAMSHEDPUR, KOCHI, KOLKATA, LUCKNOW, MADURAI, MUMBAI, NAGPUR, NOIDA, PARWANOO, PATNA, PUNE, RAIPUR, RAJKOT, SURAT, VIJAYAWADA.