

सड़क वाहन — संपीड़ित प्राकृतिक गैस
(सीएनजी)/जैव-संपीड़ित प्राकृतिक गैस
(जैव-सीएनजी), ईंधन प्रणाली के
घटक — कार्यकारिता एवं सामान्य परीक्षण
पद्धतियाँ
(पहला पुनरीक्षण)

Road Vehicles — Compressed
Natural Gas (CNG)/Bio-compressed
Natural Gas (Bio-CNG), Fuel System
Components — Performance and
General Test Methods
(First Revision)

ICS 43.060.40

© BIS 2024



भारतीय मानक ब्यूरो
BUREAU OF INDIAN STANDARDS
मानक भवन, 9 बहादुर शाह ज़फर मार्ग, नई दिल्ली - 110002
MANAK BHAVAN, 9 BAHADUR SHAH ZAFAR MARG
NEW DELHI - 110002
www.bis.gov.in www.standardsbis.in

FOREWORD

This Indian Standard (First Revision) was adopted by the Bureau of Indian Standards, after the draft finalized by the Automotive Vehicles Running on Non-conventional Energy Sources Sectional Committee had been approved by the Transport Engineering Division Council.

This standard was first published in 2006 to specify performance and general test methods for CNG/bio-CNG on board fuel system components, intended for use on motor vehicles defined in IS 14272. In this revision, bio-CNG is added to the scope of this standard keeping in view the technological advancements that have taken place since its last publication.

In the formulation of this standard considerable assistance has been derived from the following standards issued by the Automotive Research Association of India and the International Organization for Standardization respectively:

AIS 024 (Revision 1) (Part A) — Safety and procedural requirements for type approval of gaseous fuelled vehicles — Part A (Automotive application)

AIS 024 (Revision 1) (Part B) — Safety and procedural requirements for type approval of gaseous fuel agricultural tractors — Part B (Agricultural tractors application)

AIS 024 (Revision 1) (Part C) — Safety and procedural requirements for type approval of gaseous fuel vehicles — Part C (CEV's application)

AIS 028 (Revision 1) (Part A) — Code of Practice for Use of Gaseous Fuels in Internal Combustion Engine Vehicles — Part A (Automotive application)

AIS 028 (Revision 1) (Part B) — Code of practice for use of gaseous fuels in internal combustion engine agricultural tractors — Part B (Agricultural tractors application)

AIS 028 (Revision 1) (Part C) — Code of practice for use of gaseous fuels in internal combustion engine construction equipment vehicles (CEV's) — Part C (CEV's application)

ISO 15500-2 : 2016 'Road vehicles — Compressed natural gas (CNG) fuel system components — Part 2: Performance and general test methods

Considering Indian climatic conditions the Committee responsible for the formulation of this standard decided to deviate from the requirement of ISO with respect to the following:

- a) Components shall be tested at a temperature of - 20° instead of - 40 °C; and
- b) Testing at room temperature shall be done at 27 °C ± 5 °C instead of 20 °C ± 5 °C.

This standard is one of the series of Indian Standards published on CNG/bio-CNG on-board fuel system components. Other standards in the series are:

<i>IS No.</i>	<i>Title</i>
IS 15710 : 2024	Road vehicles — Compressed natural gas (CNG)/bio-compressed natural gas (bio-CNG) fuel system components — General requirements and definition
IS 15712 : 2024	Road vehicles — Compressed natural gas (CNG) /bio-compressed natural gas (bio-CNG) fuel system components — Automatic valve (solenoid valve) (<i>first revision</i>)

(Continued on third cover)

Indian Standard

ROAD VEHICLES — COMPRESSED NATURAL GAS (CNG)/ BIO-COMPRESSED NATURAL GAS (BIO-CNG) FUEL SYSTEM COMPONENTS — PERFORMANCE AND GENERAL TEST METHODS (*First Revision*)

1 SCOPE

1.1 This standard specifies performance and general test methods for CNG/bio-CNG on board fuel system components, intended for use on motor vehicles defined in IS 14272.

1.2 This standard is applicable to CNG/bio-CNG fuel system components intended to use on vehicles using compressed natural gas/bio-compressed natural gas in accordance with IS 15320 (Part 1) (mono-fuel or bi-fuel applications or dual fuel applications). This standard is not applicable to the following:

- a) Liquefied natural gas (LNG) fuel system components located upstream of, and including, the vaporizer;
- b) Fuel containers;
- c) Stationary gas engines;
- d) Container mounting hardware;
- e) Electronic fuel management;
- f) Refuelling receptacles;
- g) CNG/bio-CNG fuel systems components for the propulsion of marine craft; and
- h) Hydrogen natural gas blend (HCNG) fuel system components.

1.3 This standard is based upon a service pressure for compressed natural gas/bio-compressed natural gas as a fuel at 20 MPa (200 bar) settled at 15 °C. Other service pressures could be accommodated by adjusting the pressure by the appropriate factor (ratio). For example, a 25 MPa (250 bar) service pressure system will require pressures to be multiplied by 1.25. All references to pressure are to be considered gauge pressures unless otherwise specified.

2 REFERENCES

The standards listed in [Annex A](#) contain provisions which, through reference in this text, constitute

provisions of this standard. At the time of publication, the editions indicated were valid. All standards are subject to revision and parties to agreements based on this standard are encouraged to investigate the possibility of applying the most recent edition of these standards.

3 TERMS AND DEFINITIONS

For the purposes of this standard, the terms and definitions given in IS 15710 shall apply.

4 GENERAL

4.1 Unless otherwise stated, the tests shall be conducted at room temperature that is $27\text{ °C} \pm 5\text{ °C}$.

4.2 Components shall comply with the tests specified in their relevant specifications, as well as the applicable tests specified in this standard. Because of the peculiarities of some components, the list of tests given in this standard (*see 5 to 15*) is not exhaustive. Where additional tests are required, their provisions are given in another, relevant standard.

4.3 Unless otherwise specified, all tests shall be conducted using dry air or nitrogen. Qualified personnel may also test with natural gas provided that appropriate safety measures are taken. The dew point of the test gas at the test pressure shall be at the temperature at which there is no icing, or hydrate or liquid formation.

4.4 It is recognized that new technology may not be covered in the relevant specifications of components.

5 HYDROSTATIC STRENGTH

A component shall not rupture when subjected to the following test procedure:

- a) Plug the outlet opening of the component and have the valve seats or internal blocks assume the open position. Apply, with a

test fluid, the, hydrostatic pressure specified in their relevant specification to the inlet of the component for a period of at least 3 min; and

- b) The sample used in this test shall not be used for any other testing.

6 LEAKAGE

6.1 General

6.1.1 Prior to conditioning, purge the component or device with nitrogen and then seal it at 30 percent of service pressure using nitrogen, dry air or natural gas.

6.1.2 Conduct all tests while the device is continuously exposed to the specified test temperatures. The device shall either be bubble-free or have a leakage rate of less than 20 $\text{N.cm}^3/\text{h}$ (the symbol 'N' indicates conversion to normal temperature and pressure condition, NTP, that is, 760 mm Hg pressure and 0 °C temperature) using the following test method.

6.2 External Leakage

6.2.1 Plug each device outlet with the appropriate mating connection and apply the test pressure to the inlet.

6.2.2 Apply pressurized air, nitrogen, or natural gas to the test device.

6.2.3 At all test temperatures, immerse the components in a suitable test medium for 2 min or use a helium vacuum test (global accumulation method) or other equivalent method.

6.2.4 If there are no bubbles for the specified time period, the sample passes the test. If bubbles are detected measure the leak rate by an appropriate method.

6.3 Internal Leakage

6.3.1 The internal leakage test is applicable only to devices having a closed position. The aim of this test is to check the pressure tightness of the closed system.

6.3.2 Connect the inlet or outlet (as applicable) of the device, with the appropriate mating connection, while leaving the opposite connection or connections open.

6.4 Test Conditions

6.4.1 General

The leakage test conditions depend on whether the

component is exposed to cylinder pressure or located downstream of the first stage of pressure reduction.

6.4.2 Devices Exposed to Cylinder Pressure

6.4.2.1 The device shall be conditioned at least 8 h at a low temperature of - 20 °C and pressurized at 75 percent and 2.5 percent of service pressure.

6.4.2.2 The device shall be conditioned at least 8h at a room temperature of 27 °C ± 5 °C and pressurized at 2.5 percent and 150 percent of service pressure.

6.4.2.3 The device shall be conditioned at least 8 h at a high temperature of 85 °C or 120 °C and pressurized at 5 percent and 150 percent of service pressure.

6.4.3 Devices Downstream of the First Stage of Pressure Reduction

6.4.3.1 The device shall be conditioned at a low temperature of - 20 °C and pressurized at 75 percent and 2.5 percent of working pressure.

6.4.3.2 The device shall be conditioned at a room temperature of 27 °C ± 5 °C and pressurized at 2.5 percent and 150 percent of working pressure.

6.4.3.3 The device shall be conditioned at a high temperature of 85 °C or 120 °C and pressurized at 5 percent and 150 percent of working pressure.

7 EXCESS TORQUE RESISTANCE

A component designed to be connected directly to threaded fittings shall be capable of withstanding, without deformation, breakage or leakage, a torque effort of 150 percent of the rated installation value, according to the following test procedure:

- a) Test an unused component, applying the torque adjacent to the fitting;
- b) For a component having a threaded connection or threaded connections, apply the turning effort for 15 min, release it then remove the component and examine it for deformation and breakage; and
- c) Subject the component to the leakage test specified in [6](#).

8 BENDING MOMENT

A component shall be capable of operation without cracking, breaking, or leaking when tested according to the following procedure:

- a) Assemble the connections of the component, leak-tight to an appropriate mating connection or connections, representative of design intent. After assembly, the length of the inlet tubing shall be greater than 300 mm (see Fig. 1);
- b) The outlet connection shall be rigidly supported, 25 mm from the component outlet, except in the following cases:
 - 1) If the component has an integral mounting means independent of the inlet and outlet connections, the component shall be mounted using the integral mounting means specified by the manufacturers;
 - 2) If the component is intended to be mounted by either the integral mounting means or the component outlet, the mounting means that produces the most severe test condition shall be used;
 - 3) Check this assembly for leaks prior to subjecting it to 'd)';
- 4) With the component in the closed position, pressurize the system to 5 kPa (50 mbar) and apply a force according to Table 1, 300 mm from the inlet, maintaining it for 15 min. Without removing the force, check the component for leakage, in accordance with the test method given in 6, at room temperature;

NOTE — Depending on how this test is performed raising the load to compensate buoyancy could be necessary.
- c) Conduct the procedure as mentioned in 'd)' four times, rotating the component 90° around the horizontal axis between each test. Between tests, open and close (if applicable) the component three times with the bending moment removed; and
- d) At the completion of the above tests, remove the component and examine it for deformation; then subject it to the leakage test according to 6.

Table 1 Bending Moment Test Force

(Clause 8)

SI No.	Outside Diameter of Tubing, mm	Force N
(1)	(2)	(3)
i)	6	3.4
ii)	8	9.0
iii)	≥ 12	17.0

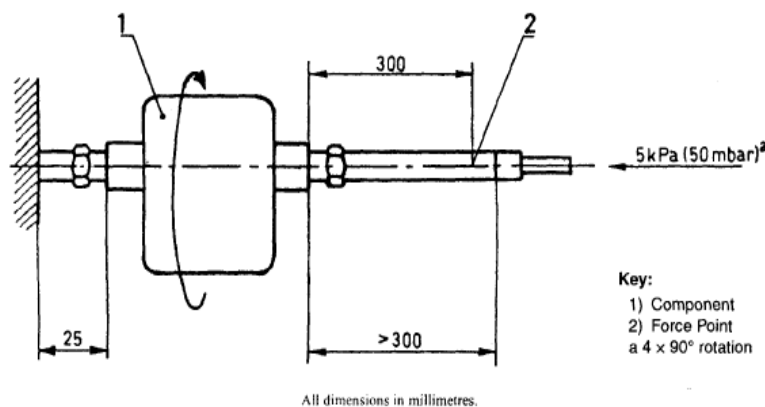

FIG. 1 BENDING MOMENT

9 CONTINUED OPERATION

9.1 General

For the details of test methods for particular components, *see* their relevant standard. The method specified in [9](#) is general in nature and also applies to miscellaneous components.

9.2 Test Method

9.2.1 Test Procedure

Connect the component securely by a suitable fitting to a pressurized source of dry air, nitrogen or natural gas and subject it to the number of cycles specified in their relevant specification. A cycle shall consist of one opening and (if applicable) one closing of the component within a period of not less than $10\text{ s} \pm 2\text{ s}$.

During the off-cycle, the downstream pressure of the test fixture shall be lowered to a maximum of 50 percent of the test pressure.

In the case of components downstream of the first stage of pressure reduction, the test pressure shall be based on 100 percent of the working pressure.

Unless otherwise specified, the conditions of [9.2.2](#) and [9.2.3](#) apply.

9.2.2 Room Temperature Cycling

Operate the component through 96 percent of the total cycles at room temperature and at service pressure, according to [6](#). This test may be interrupted, if desired, at 20 percent intervals for leakage testing.

9.2.3 High Temperature Cycling

Operate the component through 2 percent of the total cycles at the appropriate maximum temperature specified in [4.4](#) of IS 15710, at service pressure. The component shall comply with [6](#) at the appropriate maximum temperature at the completion of the high temperature cycles.

9.2.4 Low Temperature Cycling

Operate the component through 2 percent of the total cycles at the appropriate minimum temperature specified in [4.4](#) of IS 15710 at 50 percent service pressure. The component shall comply with [6](#) at the appropriate minimum temperature at the completion of the low temperature cycles.

10 CORROSION RESISTANCE

10.1 All components shall perform safely and in compliance with [6](#) following exposure to salt spray according to the following test method.

10.2 With the component supported in its normal installed position, expose it for 96 h to a salt spray (fog) test as specified in IS 9844.

10.3 Maintain the temperature within the fog chamber at between $33\text{ }^{\circ}\text{C}$ and $36\text{ }^{\circ}\text{C}$.

10.4 The saline solution shall consist of 5 percent sodium chloride and 95 percent distilled water, by weight.

10.5 Immediately following the corrosion test, rinse the sample and gently clean it of salt deposits; then subject it to the tests according to [6](#).

11 OXYGEN AGEING

All synthetic or non-metallic parts of components that provide a fuel-containing seal for which a satisfactory declaration of properties is not submitted by the applicant shall not crack or show visible evidence of deterioration after oxygen ageing when tested according to the following procedure.

Subject representative samples to 96 h of exposure to oxygen at a temperature of $70\text{ }^{\circ}\text{C}$, at 2 MPa (20 bar) in accordance with IS 3400 (Part 4).

12 ELECTRICAL OVERVOLTAGE

All electrical components or devices containing electrical subcomponents shall withstand the application of 1.5 times the rated voltage ± 5 percent for periods of 3 min without failure.

13 NON-METALLIC SYNTHETIC IMMERSION

13.1 Non-metallic synthetic material used in a component shall be subjected by the test agency to the tests described in [13.2](#) and [13.3](#), except where the applicant submits declarations of results of tests carried out on the material provided by the manufacturer.

13.2 A part made of non-metallic synthetic material in contact with natural gas shall not show excessive change in volume or weight when tested according to the following procedure:

- a) Prepare, measure and weigh a

representative sample or samples of each non-metallic synthetic material used in a component, then immerse the sample or samples at room temperature in natural gas at a pressure of 20 MPa (200 bar) for a minimum of 70 h; and

- b) Following this period of immersion, rapidly reduce the test pressure to atmospheric pressure without causing shredding or disintegration. No tested sample shall exhibit swelling greater than 25 percent or shrinkage greater than 1 percent. The weight change shall not exceed 10 percent.

13.3 Non-metallic synthetic material used in a component that could be exposed to ester-based or alpha olefin-based synthetic compressor oils, including non-synthetic compressor oils, shall not show excessive change in volume or weight when tested in accordance with IS 3400 (Part 6) or the following procedure:

- a) Prepare, measure and weigh a representative sample or samples of each non-metallic synthetic material used in a component, then immerse the sample or samples at room temperature in holders each containing one of the test fluids for a minimum of 70 h; and
- b) Following this period of immersion, remove and measure the test samples. No sample shall exhibit swelling greater than 25 percent or shrinkage greater than 1 percent. The weight change shall not exceed 10 percent.

14 VIBRATION RESISTANCE

All components with moving parts shall remain undamaged, and shall continue to operate and meet the requirements of their leakage tests after 6 h of vibration carried out according to the following test procedure:

- a) Secure the component in a test apparatus and vibrate for 2 h at 17 Hz with an

amplitude of 1.5 mm in each of three orientation axes; and

- b) On completion of this total of 6 h vibration, the component shall comply with the requirements of [6](#).

15 BRASS MATERIAL COMPATIBILITY

All fuel-containing brass components or subcomponents for which a satisfactory declaration of properties is not submitted by the applicant shall be tested according to the following procedure (component manufacturers able to provide documentation attesting to the field worthiness of their products are exempted from this requirement).

- a) Subject each test sample to the physical stresses normally imposed on, or within a part as a result of assembly with other components. Apply these stresses to the sample prior to the test and maintain them during it. Samples with thread, intended to be used for installing the product in the field, shall have the threads engaged and tightened to the torque specified in the instruction manual of the sample. Poly-tetra fluoro ethylene (PTFE) tape or pipe compounds shall not be used on the threads; and
- b) Degrease three samples and continuously expose them for 10 d at a set position to a moist, ammonia-air mixture maintained in a glass chamber of approximately 30 litre capacity and with a glass cover. Maintain approximately 600 cm³ of aqueous ammonia, with a relative density (specific gravity) of 0.94 at the bottom of the glass chamber, below the samples. Position the samples 40 mm above the aqueous ammonia solution, supported by an inert tray. Maintain the moist ammonia-air mixture in the chamber at atmospheric pressure and at a temperature of 34 °C ± 2 °C.

After being subjected to the conditions of this procedure, samples shall show no evidence of cracking when examined at 25 × magnification.

ANNEX A

(Clause 2)

LIST OF REFERRED STANDARDS

<i>IS No.</i>	<i>Title</i>	<i>IS No.</i>	<i>Title</i>
IS 3400 (Part 4) : 2012/ISO 188 : 2011	Methods of test for vulcanized rubber: Part 4 Accelerated ageing and heat resistance (<i>third revision</i>)	IS 14272 : 2011	Automotive vehicles — Types — Terminology
IS 3400 (Part 6) : 2018/ISO 1817 : 2015	Methods of test for vulcanized rubbers: Part 6 Determination of the effect of liquids (<i>fourth revision</i>)	IS 15320 (Part 1) : 2012/ISO 15403-1 : 2006	Natural gas — Natural gas for use as a compressed fuel for vehicles: Part 1 Designation of the quality (<i>first revision</i>)
IS 9844 : 1981	Methods of testing corrosion resistance of electroplated and anodized aluminium coatings by neutral salt spray test	IS 15710 : 2024	Road vehicles — Compressed natural gas (CNG)/ bio-compressed natural gas (bio-CNG) fuel system components — General requirements and definition

To access Indian Standards click on the link below:

https://www.services.bis.gov.in/php/BIS_2.0/bisconnect/knowyourstandards/Indian_standards/isdetails/

ANNEX B

(Foreword)

COMMITTEE COMPOSITION

Automotive Vehicles Running on Non-Conventional Energy Sources Sectional Committee, TED 26

<i>Organization</i>	<i>Representative(s)</i>
Automotive Research Association of India (ARAI), Pune	DR S. S. THIPSE (Chairperson) SHRI A. D. DEKATE
A B Process Technologies, Pune	SHRI KUNAL CHOPDE
Ashok Leyland Ltd, Chennai	SHRIMATI SUCHISMITA C. SHRI MUTHUKUMAR N. (<i>Alternate</i>)
Automotive Component Manufactures Association of India, New Delhi	SHRI SANJAY TANK SHRIMATI SEEMA BABAL (<i>Alternate</i>)
Bajaj Auto Ltd, Pune	SHRI MILIND J. PAGARE SHRI ARVIND V. KUMBHAR (<i>Alternate</i>)
Bosch Limited, Bengaluru	SHRI BHARADWAJ M. KRISHNAMURTHY SHRI VIKRAM K. (<i>Alternate</i>)
Central Institute of Road Transport, Pune	SHRI SAMIR SATTIGERI SHRI V. V. JOSHI (<i>Alternate</i>)
Central Pollution Control Board, New Delhi	SHRI A. SUDHAKAR SHRI SUNEEL DAVE (<i>Alternate I</i>) SHRI KEDARNATH DASH (<i>Alternate II</i>)
CLH Gaseous Fuel Applications Ltd, Gurgaon	SHRI SHISHIR AGRAWAL SHRI GAGAN AGRAWAL (<i>Alternate</i>)
Delhi Transport Corporation, New Delhi	SHRI VIKAS BATRA
GAIL (India) Limited, New Delhi	SHRI ASHISH KUMAR MITTAL SHRI LOKESH MEHTA (<i>Alternate</i>)
Indian Auto LPG Coalition, Faridabad	SHRI SHISHIR AGRAWAL SHRI SUYASH GUPTA (<i>Alternate</i>)
Indian Institute of Petroleum, Dehradun	SHRI WITTISON KAMEI SHRI ROBINDRO LAIRENLAKPAM (<i>Alternate</i>)
Indian Institute of Science, Bengaluru	PROF R. V. RAVIKRISHNA
Indian Institute of Technology Ropar, Punjab	SHRI DHIRAJ KUMAR MAHAJAN DR DEBAPRASAD MANDAL (<i>Alternate</i>)
Indian Oil Corporation Ltd., (R & D Centre), Faridabad	DR M. SITHANANTHAN (<i>Alternate</i>)
Indian Rubber Manufacturers Research Association, Thane, Mumbai	DR K. RAJ KUMAR DR BHARAT KAPGATE (<i>Alternate</i>)
International Centre for Automotive Technology (ICAT), Manesar	SHRI VAIBHAV PRASHANT YADAV SHRI VIJAYANTA AHUJA (<i>Alternate</i>)

<i>Organization</i>	<i>Representative(s)</i>
Mahindra & Mahindra Ltd (Truck and Bus Division), Pune	SHRI V. G. KULKARNI (<i>Alternate</i>) 
Mahindra & Mahindra Ltd, Mumbai	SHRI RAJAMANI PARTHIBAN SHRI SHAILESH KULKARNI (<i>Alternate</i>)
Maruti Suzuki India Limited, Gurugram	SHRI GURURAJ RAVI SHRI ARUN KUMAR (<i>Alternate</i>)
Minda Emer Technologies Limited, Gurugram	SHRI VIVEK JAIN SHRI BIBHUTI KUMAR (<i>Alternate</i>)
Ministry of New and Renewable Energy, New Delhi	SHRI DIPESH PHERWANI
Petroleum and Explosive Safety Organization, Nagpur	SHRI D. K. GUPTA SHRI VIVEK KUMAR (<i>Alternate</i>)
Petronet LNG Ltd, New Delhi	SHRI PANKAJ WADHWA (<i>Alternate</i>)
Prodair Air Products India Private Ltd, Pune	SHRI RAVI SUBRAMANIAN SHRI ARUN KURUVANGATTIL (<i>Alternate</i>)
Renault India Private Limited, Mumbai	SHRI RAJENDRA KHILE SHRI VIJAY DINAKARAN (<i>Alternate</i>)
Rohan BRC Gas Equipment Pvt Ltd, Ahmedabad	SHRI STEFANO DE CAROLIS SHRI PARTHIV SHUKLA (<i>Alternate</i>)
Society of Indian Automobile Manufacturers, New Delhi	SHRI P. K. BANERJEE DR SANDEEP GARG (<i>Alternate</i>)
Swagelok – Bombay Fluid System components Pvt Ltd, Mumbai	SHRI SACHIN KOULGI SHRI HARISH TAKKE (<i>Alternate</i>)
Tata Motors Ltd, Pune	SHRI P. S. GOWRISHANKAR SHRI SHAILENDRA DEWANGAN (<i>Alternate</i>)
TVS Motor Company Ltd, Hosur	SHRI V. PATTABIRAMAN SHRI K. M. SRIKANTH (<i>Alternate</i>)
Vanaz Engineers Ltd, Pune	SHRI S. J. VISPUTE SHRI J. S. DHUMAL (<i>Alternate</i>)
Volkswagen India Pvt Ltd, Mumbai	SHRI JOREG BOUZEK SHRI PANKAJ GUPTA (<i>Alternate</i>)
BIS Directorate General	SHRI DEEPAK AGARWAL, SCIENTIST ‘F’/SENIOR DIRECTOR AND HEAD (TRANSPORT ENGINEERING) [REPRESENTING DIRECTOR GENERAL (<i>Ex-officio</i>)]

Member Secretary
SHRI GAURAV JAYASWAL
SCIENTIST ‘C’/DEPUTY DIRECTOR
(TRANSPORT ENGINEERING), BIS

(Continued from second cover)

<i>IS No.</i>	<i>Title</i>
IS 15713 : 2024	Road vehicles — Compressed natural gas (CNG)/bio-compressed natural gas (bio-CNG) fuel system components — Pressure regulator (<i>first revision</i>)
IS 15714 : 2024	Road vehicles — Compressed natural gas (CNG)/bio-compressed natural gas (bio-CNG) fuel system components — Gas air mixer (<i>first revision</i>)
IS 15715 : 2024	Road vehicles — Compressed natural gas (CNG)/bio-compressed natural gas (bio-CNG)/liquefied petroleum gas (LPG) fuel system components — CNG/bio-CNG/LPG conduit (ventilation hose/pipe) (<i>first revision</i>)
IS 15716 : 2024	Road vehicles — Compressed natural gas (CNG) /bio-compressed natural gas (bio-CNG) fuel system components — high pressure fuel line (rigid) with end connections [having pressure exceeding 2.15 MPa (21.5 bar)] (<i>first revision</i>)
IS 15717 : 2024	Road vehicles — Compressed natural gas (CNG)/bio-compressed natural gas (bio-CNG)/liquefied petroleum gas (LPG) fuel system components — Petrol valve (automatic/manual) (<i>first revision</i>)
IS 15718 : 2024	Road vehicles — Compressed natural gas (CNG)/bio-compressed natural gas (bio-CNG) fuel system components — High pressure fuel line (flexible hose) with end connections [(having pressure exceeding 2.15 MPa (21.5 bar)] (<i>first revision</i>)
IS 15719 : 2024	Road vehicles — Compressed natural gas (CNG)/bio-compressed natural gas (bio-CNG)/liquefied petroleum gas (LPG) fuel system components — Electrical wiring kit (<i>first revision</i>)
IS 15720 : 2024	Road vehicles — Compressed natural gas (CNG)/bio-compressed natural gas (bio-CNG)/liquefied petroleum gas (LPG) — Fuel system components — CNG/bio-CNG/LPG compartment/sub-compartments (<i>first revision</i>)
IS 15721 : 2024	Road vehicles — Compressed natural gas (CNG)/bio-compressed natural gas (bio-CNG)/liquefied petroleum gas (LPG) fuel system components — Fire retardant material for seat, upholstery, roof and side lining (<i>first revision</i>)
IS 15722 : 2024	Road vehicles — Compressed natural gas (CNG)/bio-compressed natural gas (bio-CNG) fuel system components flexible fuel line with end connections [CNG fuel line having pressure not exceeding 2.15MPa (21.5 bar)] (<i>first revision</i>)
IS 15723 : 2024	Road vehicles — Compressed natural gas (CNG)/bio-compressed natural gas (bio-CNG) and liquefied petroleum gas (LPG) — Fuel system components — Current limiting devices (<i>first revision</i>)

The composition of the Committee responsible for the formulation of this standard is given in [Annex B](#).

In reporting the result of a test or analysis made in accordance with this standard, if the final value, observed or calculated, is to be rounded off it shall be done in accordance with IS 2 : 2022 ‘Rules for rounding off numerical values (*second revision*)’.

Bureau of Indian Standards

BIS is a statutory institution established under the *Bureau of Indian Standards Act, 2016* to promote harmonious development of the activities of standardization, marking and quality certification of goods and attending to connected matters in the country.

Copyright

BIS has the copyright of all its publications. No part of these publications may be reproduced in any form without the prior permission in writing of BIS. This does not preclude the free use, in the course of implementing the standard, of necessary details, such as symbols and sizes, type or grade designations. Enquiries relating to copyright be addressed to the Head (Publication & Sales), BIS.

Review of Indian Standards

Amendments are issued to standards as the need arises on the basis of comments. Standards are also reviewed periodically; a standard along with amendments is reaffirmed when such review indicates that no changes are needed; if the review indicates that changes are needed, it is taken up for revision. Users of Indian Standards should ascertain that they are in possession of the latest amendments or edition by referring to the website-www.bis.gov.in or www.standardsbis.in.

This Indian Standard has been developed from Doc No.: TED 26 (15007).

Amendments Issued Since Publication

Amend No.	Date of Issue	Text Affected

BUREAU OF INDIAN STANDARDS

Headquarters:

Manak Bhavan, 9 Bahadur Shah Zafar Marg, New Delhi 110002

Telephones: 2323 0131, 2323 3375, 2323 9402

Website: www.bis.gov.in

Regional Offices:

Central : 601/A, Konnectus Tower -1, 6th Floor,
DMRC Building, Bhavbhuti Marg, New
Delhi 110002

Telephones

{ 2323 7617

Eastern : 8th Floor, Plot No 7/7 & 7/8, CP Block, Sector V,
Salt Lake, Kolkata, West Bengal 700091

{ 2367 0012
2320 9474

Northern : Plot No. 4-A, Sector 27-B, Madhya Marg,
Chandigarh 160019

{ 265 9930

Southern : C.I.T. Campus, IV Cross Road, Taramani, Chennai 600113

{ 2254 1442
2254 1216

Western : 5th Floor/MTNL CETTM, Technology Street, Hiranandani Gardens, Powai
Mumbai 400076

{ 25700030
25702715

Branches : AHMEDABAD, BENGALURU, BHOPAL, BHUBANESHWAR, CHANDIGARH, CHENNAI, COIMBATORE, DEHRADUN, DELHI, FARIDABAD, GHAZIABAD, GUWAHATI, HARYANA (CHANDIGARH), HUBLI, HYDERABAD, JAIPUR, JAMMU, JAMSHEDPUR, KOCHI, KOLKATA, LUCKNOW, MADURAI, MUMBAI, NAGPUR, NOIDA, PARWANOO, PATNA, PUNE, RAIPUR, RAJKOT, SURAT, VIJAYAWADA.