प्रकाशिकी और फोटोनिक्स — प्रकाशीय
तत्वों और प्रणालियों के लिए आरेखण
तैयार करना

भाग 13 सतहों और घटकों का सामान्य विवरण

Optics and Photonics — Preparation
of Drawings for Optical Elements
and Systems

Part 13 General Description of Surfaces
and Components

ICS 01.100.20; 37.020

© BIS 2024

© ISO 2015



भारतीय मानक ब्यूरो
BUREAU OF INDIAN STANDARDS
मानक भवन, 9 बहादुर शाह ज़फर मार्ग, नई दिल्ली - 110002
MANAK BHAVAN, 9 BAHADUR SHAH ZAFAR MARG
NEW DELHI - 110002

www.bis.gov.in www.standardsbis.in

NATIONAL FOREWORD

This Indian Standard (Part 13) which is identical to ISO 10110-19 : 2015 'Optics and photonics — Preparation of drawings for optical elements and systems — Part 19: General description of surfaces and component' issued by the International Organization for Standardization (ISO) was adopted by the Bureau of Indian Standards on the recommendation of the Optics and Photonics Sectional Committee and after approval of the Production and General Engineering Division Council.

This standard provides a general method of describing surfaces and components. This standard applies to continuous and discontinuous surfaces. It does not apply to diffractive surfaces, fresnel surfaces, ophthalmic glasses, and micro-optical surfaces.

This series of Indian Standards supersede the originally published Indian Standard IS 5920 : 1970 'Recommendation for the preparation of drawing for optical elements and system'.

This standard has been published in thirteen parts. The other parts in this series are:

Part 1	General
Part 2	Surface form tolerances
Part 3	Centering tolerances
Part 4	Surface imperfections
Part 5	Surface texture
Part 6	Surface treatment and coating
Part 7	Non-tolerance data
Part 8	Aspheric surfaces
Part 9	Wave front deformation tolerance
Part 10	Diffractive surfaces
Part 11	Laser irradiation damage threshold
Part 12	Stress birefringence, bubbles and inclusions, homogeneity, and striae

The text of ISO standard has been approved as suitable for publication as an Indian Standard without deviations. Certain conventions are, however, not identical to those used in Indian Standards. Attention is particularly drawn to the following:

- a) Wherever the words 'International Standard' appear referring to this standard, they should be read as 'Indian Standard'; and
- b) Comma (,) has been used as a decimal marker while in Indian Standards, the current-practice is to use a point (.) as the decimal marker.

Contents

Page

1	Scope	1
2	Normative references	1
3	Terms and definitions	1
4	Referencing	2
	4.1 General	2
	4.2 Coordinate system	3
	4.3 Sign convention	3
5	Drawing specifications	4
	5.1 General	4
	5.2 Specification of surface form tolerances	4
	5.3 Specification of centring tolerances	5
	5.4 Tolerance specifications for surface imperfections and surface texture	5
6	Data exchange	6
7	Data reduction	6
	Annex A (informative) Mathematical description, data formats, and data reduction	7
	Bibliography	12

Indian Standard

**OPTICS AND PHOTONICS — PREPARATION OF DRAWINGS
FOR OPTICAL ELEMENTS AND SYSTEMS
PART 13 GENERAL DESCRIPTION OF SURFACES AND COMPONENTS**

1 Scope

ISO 10110 specifies the presentation of design and functional requirements for optical elements and systems in technical drawings used for manufacture and inspection.

This part of ISO 10110 provides a general method of describing surfaces and components. This part of ISO 10110 applies to continuous and discontinuous surfaces. It does not apply to diffractive surfaces, Fresnel surfaces, ophthalmic glasses, and micro-optical surfaces.

This part of ISO 10110 applies to any general surface or component, even including spherical or rotationally symmetric surfaces if it is necessary, i.e. when NURBS, splines, point clouds, etc. are used.

This part of ISO 10110 does not specify the method by which compliance with the specifications is to be tested.

2 Normative references

The following documents, in whole or in part, are normatively referenced in this document and are indispensable for its application. For undated references, the latest edition of the referenced document (including any amendments) applies.

ISO 1101, *Geometrical Product Specifications (GPS) — Geometrical tolerancing — Tolerances of form, orientation, location and run-out*

ISO 5459, *Geometrical product specifications (GPS) — Geometrical tolerancing — Datums and datum systems*

ISO 10110-5, *Optics and photonics — Preparation of drawings for optical elements and systems — Part 5: Surface form tolerances*

ISO 10110-6, *Optics and photonics — Preparation of drawings for optical elements and systems — Part 6: Centring tolerances*

ISO 10110-7, *Optics and photonics — Preparation of drawings for optical elements and systems — Part 7: Surface imperfection tolerances*

ISO 10110-8, *Optics and photonics — Preparation of drawings for optical elements and systems — Part 8: Surface texture; roughness and waviness*

ISO 10110-14, *Optics and photonics — Preparation of drawings for optical elements and systems — Part 14: Wavefront deformation tolerance*

3 Terms and definitions

For the purposes of this document, the following terms and definitions apply.

3.1 general surface

any surface including those free from constraints of symmetry and/or form

Note 1 to entry: A general surface can be both a continuous as well as a discontinuous surface. It can contain local regular geometrical properties. In principle, any surface (e.g. conic sections, including the sphere) can be described by this part of ISO 10110 as a general surface. ISO 10110-12 offers a formalized and specific mathematical approach that is a more direct approach. The simplest description that fulfils the given requirements shall be used.

3.2 reference axis

theoretical axis given by the optical designer which does not depend on symmetries of the surface and which usually represents the centre of the optical path for the main function

Note 1 to entry: It should ensure a minimum of tolerance influence and enhance the flexibility for production. The reference axis cannot be changed and is defined once. The position and orientation of the reference axis is defined by measurable references at and/or on the general surface/component or by an approximation of the nominal surface.

3.3 transport formats

file formats for transfer of data between software systems and processing and measuring machines

EXAMPLE Typical transport formats are XML and STEP.

4 Referencing

4.1 General

The general surface is referenced with the coordinate systems used in the process chain, e.g. to define centring tolerances according to ISO 5459. A general surface can have 3 essential coordinate systems as shown in [Figure 1](#):

- the origin of the mathematical description;
- the reference coordinate system at the intersection of reference axis and surface;
- the component reference points.

NOTE If the origin of the mathematical surface description is out of the used surface area, it can be useful to provide two separated reference axes; one reference axis for the production (e.g. fast tool servo machining axis) and one reference coordinate system for measuring. Although both coordinate systems have geometric meaning, they are not physical and thus useful to be referenced by the component reference points. The referencing establishes a clear reference of the general surface, both to coordinate systems of processing machines and measuring devices as well as higher-level assemblies.

For referencing, specifications shall be available for the clear orientation of the general surface according to its position and direction (6 degrees of freedom) relative to component reference points. For referencing planes, cylinders, cones, or spheres shall be included. Reference marks in the form of crosses, circles, or lines and combinations of the specified structures can also be used. The references may be in any position on the work piece. An example is illustrated in [Figure 1](#).

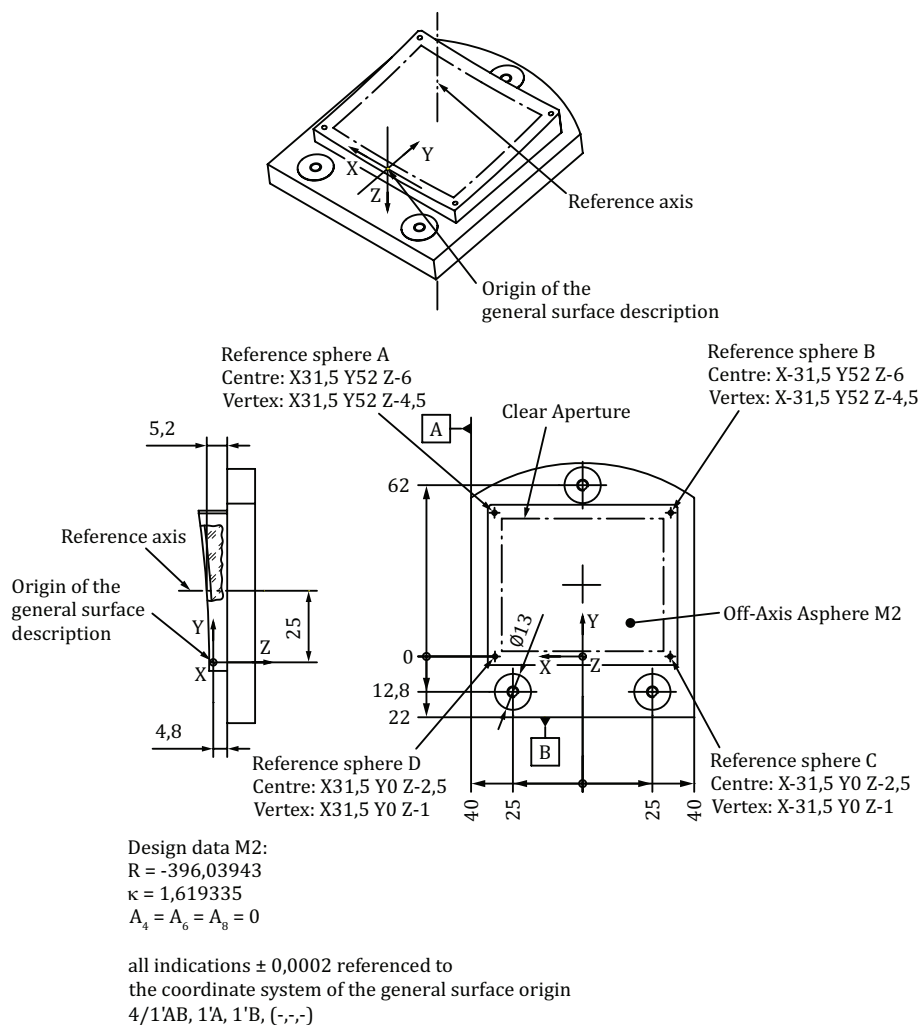

Figure 1 — Off-axis asphere drawn as general component with reference structures

4.2 Coordinate system

The coordinate system is in three axes (X, Y, Z) orthogonal to each other and follows the right hand rule (right-handed system). The coordinate origin should be on the reference axis and the general surface (see Figure 2). In this case, the Z-axis of the coordinate system will represent the reference axis. Once defined, the position and orientation of the coordinate system shall not be changed.

Unless otherwise specified, the Z-axis is in the plane of the drawing and runs from left to right. If only one cross-section is drawn, the Y-axis is in the plane of drawing and is oriented upwards.

If two cross-sections are drawn, the XZ cross-section shall appear below the YZ cross-section. For clarity, the X and Y axes can be shown on the drawing.

4.3 Sign convention

As laid down in later clauses of this part of ISO 10110, the various general surfaces are specified by mathematical equations or vectors. To achieve clear surface specifications, the following sign conventions for the constants, vectors, and coefficients shall be used.

The sagitta of a point on the general surface is positive if it lies in the positive Z direction from the XY plane and negative if it lies in the negative Z direction from the XY plane.

5 Drawing specifications

5.1 General

A general surface shall be represented in the same manner as a spherical component (see ISO 10110-1). The specification of the radius of curvature shall be replaced by the abbreviation “GS” (for “General Surface”).

The origin of the general surface shall be specified on the drawing.

The component references shall be marked and dimensioned to the coordinate system of the general surface.

The general surface may be represented in an exaggerated manner on the drawing to illustrate these factors. The part shall be marked accordingly. In addition, the drawing shall contain a sagitta table (see [Table 1](#)). It shall allow the point-by-point testing of the transferred surface form on the basis of Cartesian coordinates or Polar coordinates for *Z*, the sagitta, and *S*, the surface slope. The required accuracy and uniformly complete distribution shall be ensured in the point-by-point testing method. In addition to the sagitta, the slope is specified as a control value.

Table 1 — Example of a sagitta table

<i>X</i>	<i>Y</i>	<i>Z</i>	<i>S</i>	<i>I</i>	$\Delta S_{x, 1\text{-dim}}$	$\Delta S_{2\text{-dim}}$
0,0	0,0	0,000 000	7,023 15°	—	—	—
5,0	0,0	7,231 564	1,213 64°	—	—	—
0,0	5,0	3,201 487	5,812 36°	—	—	—
5,0	5,0	3,024 566	2,847 48°	0,000 5	0,3'	0,1'
-5,0	5,0	4,558 790	1,834 70°	0,000 7	0,5'	0,3'
..
15	-10	12,345 300	2,455 34°	0,001 0	0,9'	0,4'
					(1/0,1)	(4/0,2)

A note shall be added to the drawing indicating the selected form of mathematical description or a corresponding data file with the corresponding constants, vectors, and coefficients.

If there is no data file for exchanging data between CAD and other systems, the mathematical description shall be specified on the drawing. If there is a data file for exchanging data between CAD and other systems, it shall be specified on the 2D drawing of the individual part near the general surface. An unambiguous file name (e.g. date stamp, version number) including data file extension shall be given.

An example of the representation is shown in [Figure 2](#).

5.2 Specification of surface form tolerances

Surface form tolerances shall be specified in one of the following ways:

- according to ISO 1101;
- according to ISO 10110-5 (code number 3/) or ISO 10110-14 (code number 13/);

NOTE According to ISO 10110-14, it is possible to specify only one tolerance for the deformation of the wavefront without any need to specify tolerances for individual surfaces.

- in a table that indicates the permissible form and slope deviations as well as sampling interval and integration length. The specification can be made in addition to the sagitta table.

In each of the three cases, the permissible slope deviation shall also be indicated as an absolute quantity in (X,Y) or (ρ, φ) . The local slope deviation is the local angle deviation of the normal of the real surface from the normal of the theoretical surface.

5.3 Specification of centring tolerances

Centring tolerances shall be specified according to ISO 1101 or ISO 10110-6.

5.4 Tolerance specifications for surface imperfections and surface texture

Tolerance specifications for surface imperfections and surface texture shall be made in accordance with ISO 10110-7 and ISO 10110-8.

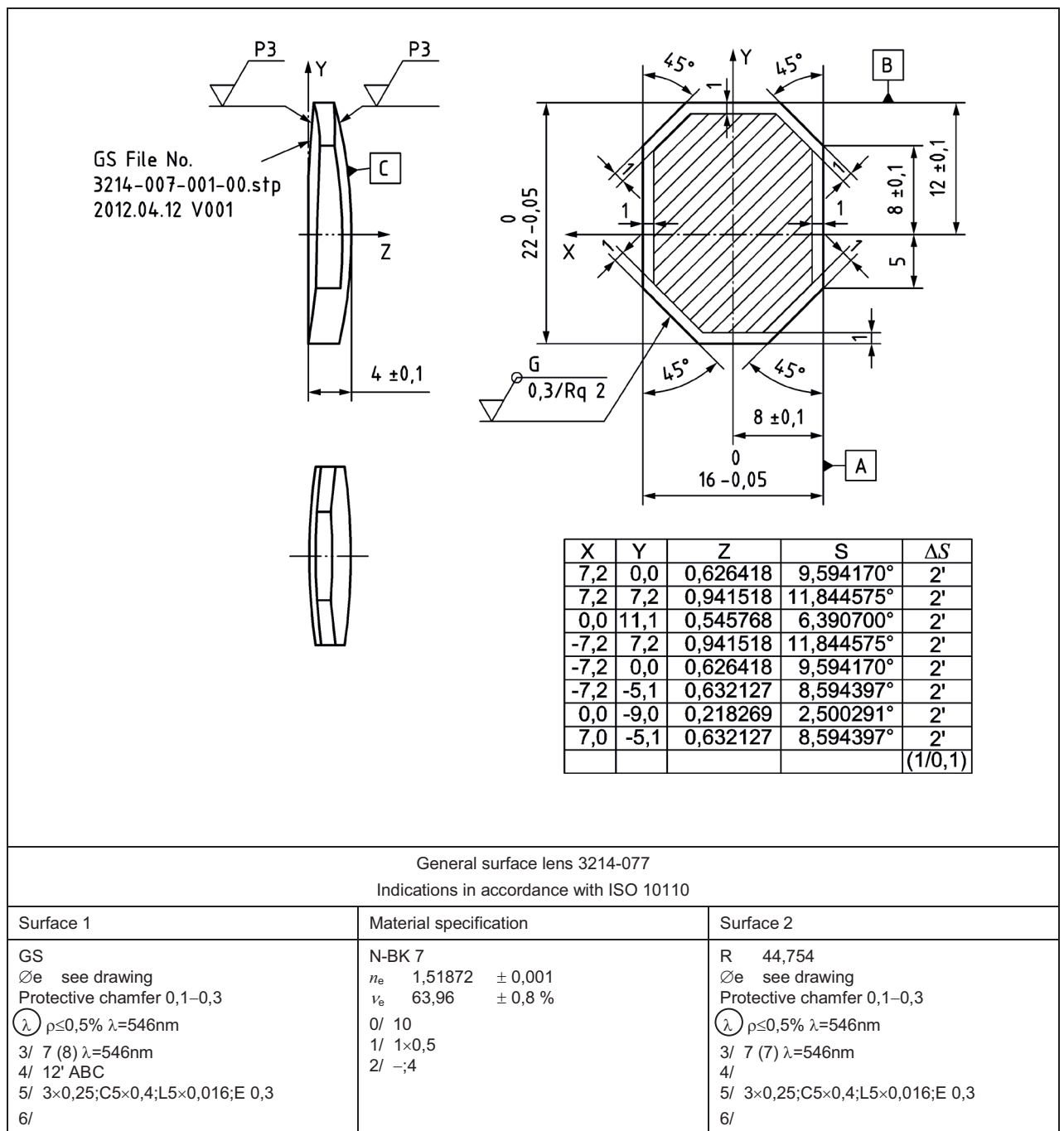

Figure 2 — Example of drawing of a general surface part including the specification of the data file on the drawing (alternatively in the labelling field for the relevant surface)

6 Data exchange

Uniform transport formats (e.g. XML, STEP) shall be used for transfer of general surface data between software systems and processing and measuring machines. When using the transport formats, it shall be ensured that all the general surface data, including forms of mathematical description, coordinate system, and reference are reliably mapped. When transferring data, it shall be ensured that the data import includes all decimal digits and uses the correct measuring unit.

A sagitta table shall be specified to test the transferred surface description. The specification can be made in Cartesian coordinates (XY polynomials) and in Polar coordinates (Zernike polynomials) (see [Tables 2](#) and [3](#)). The corresponding nominal values for Z and the slope shall be specified using (X,Y) or (R,φ) coordinates. Here, it shall be ensured that the specification of both of these values is made with sufficient accuracy. In general, the following will hold for Z and similarly for the slope S . The maximum deviation of the values after the data is transferred should be carefully determined.

NOTE 1 For example, the following criteria are recommended:

- one hundredth of the smallest peak-to-valley value; or
- one tenth of the smallest RMS requirement on this surface.

NOTE 2 The specifications of the sagitta table are necessary, but not sufficient to completely describe the general surface.

Table 2 — Example of a sagitta table in Cartesian coordinates

X	Y	Z	S
0,0	0,0	5,213 218	7,023 156°
5,0	0,0	7,231 564	1,213 648°
5,0	5,0	3,201 487	5,812 364°
..

Table 3 — Example of a sagitta table in polar coordinates

ρ	φ	Z	S
0,0	0,00°	3,346 545	10,245 650°
5,0	1,57°	1,357 573	8,145 679°
5,0	3,14°	2,346 239	2,145 876°
..

7 Data reduction

If data reduction is necessary, the used method shall be indicated near the filename on the drawing.

Annex A (informative)

Mathematical description, data formats, and data reduction

A.1 Mathematical description

A.1.1 General

General surfaces can be described by various forms of mathematical representation. Here, a distinction is made between discrete (e.g. point clouds, polygon meshes,...) and analytical (e.g. polynomials, NURBS,...) forms of description. It should be ensured that the form of representation within the free aperture provides a sufficiently accurate description of the general surface.

In addition, it should be ensured that cropping, supplementing, or limiting the general surfaces does not change the surface geometry within the free aperture.

There are other forms of representation for general surfaces that are not included in this part of ISO 10110.

A.1.2 Point clouds

Point clouds are a general form of representing general surfaces and are frequently used in metrology. The general surface can be represented using individual points $\{P_i\}$. The points are described using a (X,Y,Z) or (R, ϕ ,Z) number triplet. The accuracy of the surface is determined using the number of points and the chosen grid (see [Figure A.1](#)).

NOTE The point cloud description has a risk of drop-out points and under sampling slope as shown in [Figure A.1](#).

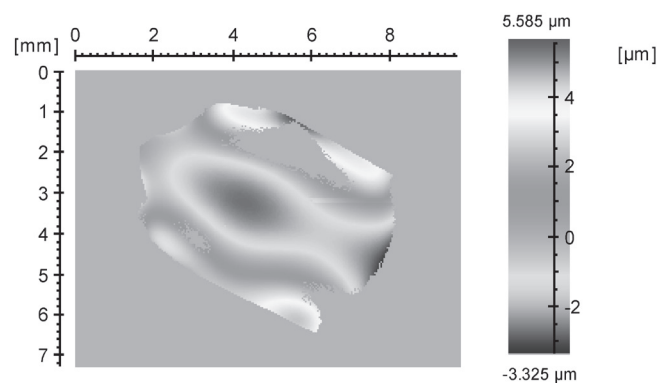

Figure A.1 — Representation of a general surface by a point cloud

A.1.3 Polygon meshes

The values are recorded as a quantity of a number triplets $\{(P_1, P_2, P_3)_i\}$, i.e. three discrete values are connected to form a triangle in each case and therefore allow the values to be converted into a two-dimensional representation(see [Figure A.2](#)).

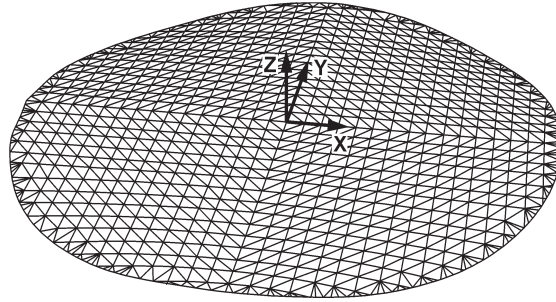

Figure A.2 — Polygonal representation of a general surface

A.1.4 Analytically defined surfaces (polynomials)

A.1.4.1 General

Two-dimensional functions $z = f(x, y)$ or $z = f(\rho, \varphi)$, e.g. XY polynomials or orthogonal polynomials, serve as an analytical form of description.

A.1.4.2 XY polynomials

$$z = \frac{C_x x^2 + C_y y^2}{1 + \sqrt{1 - (1 + \kappa_x) C_x^2 x^2 - (1 + \kappa_y) C_y^2 y^2}} + \sum_{m,n=0}^{\infty} A_{m,n} x^m y^n \quad (\text{A.1})$$

where

C_x is the surface curvature in x ;

C_y is the surface curvature in y ;

κ_x is the conical constant in x ;

κ_y is the conical constant in y ;

$A_{m,n}$ are constants.

A.1.4.3 Orthogonal polynomials

For surfaces with circular apertures, the polynomial description can be simplified due to the orthogonal properties of the Zernike or Forbes polynomials (see References [1] and [2]).

For surfaces with non-circular apertures, these polynomials are no longer orthogonal and do not offer any advantages over other sets of functions. Corresponding descriptions, including the specification of the Zernike polynomials, are given in ISO/TR 14999-2:2005, Table A.2. For surfaces with rectangular apertures, the polynomial description can be simplified due to the orthogonal properties of the appropriate polynomials. Sets of functions are described in ISO/TR 14999-2:2005.

A.1.5 Non-uniform rational basis spline surfaces (NURBS surfaces)

Non-uniform rational basis spline surfaces (NURBS surfaces) are a form of surface description using a network of weighted control points, the degree of the basic functions and their parameterization. A NURBS surface is clearly defined by a bidirectional control network of points $\{P_{i,j}\}$ with $i \in \{0, \dots, n\}$,

$j \in \{0, \dots, m\}$, a quantity of associated weights $\{w_{i,j}\}$, two node vectors $U = \{u_0, \dots, u_n\}$, $V = \{v_0, \dots, v_m\}$, and a degree p . The points $C(u,v)$ of the surface can be calculated using Formula (A.2):

$$C(u,v) = \frac{\sum_{i=0}^n \sum_{j=0}^m N_{i,p}(u) N_{j,p}(v) w_{i,j} P_{i,j}}{\sum_{i=0}^n \sum_{j=0}^m N_{i,p}(u) N_{j,p}(v) w_{i,j}} \quad (\text{A.2})$$

When representing analytically defined surfaces as NURBS surfaces, it should be ensured that the values presented in Clause 6 are not exceeded.

For further information, see Reference [3].

See also Figures A.3 and A.4.



NOTE Control points $P = \{\{0,0\},\{0,2\},\{2,3\},\{4,0\},\{6,3\},\{8,2\},\{8,0\}\}$ and the corresponding degree 3 NURBS curve with the node vector $U = \{0,0,0,0,1/4,2/4,3/4,1,1,1,1\}$ and weighting vector $W = \{1,1,1,1,4,1,1\}/10$.

Figure A.3 — Example of a section through a NURBS surface diagram

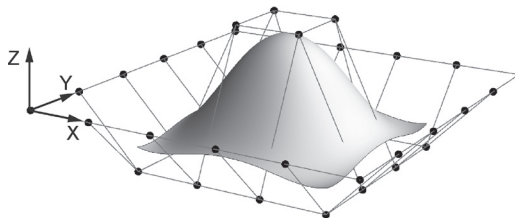

Figure A.4 — Example of a degree 3 NURBS surface and polygon mesh of the corresponding control points

A.2 Data formats

A.2.1 TXT

There is no standardized interface to represent point clouds. Since it is a relatively simple form of representation, text files in the (X,Y,Z) or (ρ,φ,Z) form are used.

A.2.2 STL

STL (Stereo lithography Tessellation Language) is not an internationally standardized exchange format, but it is a widely used non-proprietary exchange format for geometry elements. A specification of the STL format is provided in Reference [4].

It can be generated by a CAD volume model, which is broken down into layers. The object's surface is described as a polygon mesh with the aid of triangular facets.

A.2.3 STEP

STEP is a CAD exchange format standardized according to ISO 10303 and ISO 25297-1. This format supports the transport of all data of a product during its entire life cycle.

A.2.4 IGES

IGES is not an internationally standardized exchange format, but it is a widely used non-proprietary exchange format for geometry elements. A specification of the IGES format is provided in Reference [5].

A.2.5 XML format

Data can be exchanged in XML format, which is generated based on the standardized property according to ISO 13584-42. Each property is assigned a clear code allowing it to be identified. This ensures that at every point of the data exchange the receiving system is always precisely known, as well as the data it receives and how it shall be processed.

Other file formats can be referenced within the XML format. A property with a clear code within the XML format refers to a file, which can have any format, e.g. point clouds, STEP files, IGES files, or other company-specific XML definitions.

A.3 Data reduction

A.3.1 General

An appropriate method for data reduction should be chosen, depending on the form of representation. The data should be reduced so that all specifications and requirements for the tolerances and accuracy are preserved.

The accuracy requirement, according to Clause 6, should be observed when reducing data.

A.3.2 Point clouds

In case of point clouds, the quantity of data can be reduced or smoothed by deleting points either inside (data reduction) or outside (data smoothing) a tolerance using a filter algorithm. It should be noted that reducing data increases the inaccuracy.

With measured data, which is usually available as point clouds, the data will have to be smoothed depending on the measuring system and the object properties used.

A.3.3 Polygon meshes

In the case of polygon meshes, the tolerance should be maintained when reducing the polygon. With regard to the newly generated polygon mesh, a maximum distance can be measured or specified as an input variable in all cases, which may not be exceeded. This corresponds to the permissible tolerance while maintaining the required accuracy.

In the case of polygon meshes, data can be reduced with algorithms, such as error-based vertex clustering that reduces the node quantity of polygons within a tolerance.

A.3.4 Polynomial surfaces

In the case of surfaces defined by formulas, data reduction is generally not necessary, since this form of representation does not generally require a large quantity of data. The only point to be noted here is that the tolerance shall be upheld in the case of a discretisation. In this case, the maximum deviation is recalculated by comparing the resulting polygon mesh and the formula-based surface. If data has been reduced, it should be ensured that the tolerance is changed for the newly generated data accordingly, or a note should be made indicating that the data was reduced.

A.3.5 NURBS surfaces

With the “knot removal” method (see Reference [\[3\]](#)), the required data quantity for representing NURBS surfaces can be reduced with a loss in accuracy.

Bibliography

- [1] BORN M., & WOLF E. Principles of Optics, Pergamon press, Elmsford, New York.
- [2] FORBES G.W. Characterizing the Shape of Freeform Optics. Opt. Express. 2012 January 30, **20** (3) pp. 2483–2499. DOI:10.1364/OE.20.002483
- [3] PIEGL L., & TILLER W. The NURBS Book. XIV, Second Edition, 1997, p.
- [4] IEC 62050:2005, *VHDL Register Transfer Level (RTL) synthesis (IEEE 1076.6:2004)*
- [5] INITIAL GRAPHICS EXCHANGE SPECIFICATION IGES 5.3 ANS US PRO/IPO-100-1996 ANSI Approved September 23, 1996
- [6] ISO 10110-1, *Optics and photonics — Preparation of drawings for optical elements and systems — Part 1: General*
- [7] ISO 10110-2, *Optics and optical instruments — Preparation of drawings for optical elements and systems — Part 2: Material imperfections — Stress birefringence*
- [8] ISO 10110-3, *Optics and optical instruments — Preparation of drawings for optical elements and systems — Part 3: Material imperfections — Bubbles and inclusions*
- [9] ISO 10110-4, *Optics and optical instruments — Preparation of drawings for optical elements and systems — Part 4: Material imperfections — Inhomogeneity and striae*
- [10] ISO 10110-9, *Optics and optical instruments — Preparation of drawings for optical elements and systems — Part 9: Surface treatment and coating*
- [11] ISO 10110-10, *Optics and photonics — Preparation of drawings for optical elements and systems — Part 10: Table representing data of optical elements and cemented assemblies*
- [12] ISO 10110-11, *Optics and photonics — Preparation of drawings for optical elements and systems — Part 11: Non-toleranced data*
- [13] ISO 10110-12, *Optics and photonics — Preparation of drawings for optical elements and systems — Part 12: Aspheric surfaces*
- [14] ISO 10110-17, *Optics and photonics — Preparation of drawings for optical elements and systems — Part 17: Laser irradiation damage threshold*
- [15] ISO 10303, *Industrial automation systems and integration — Product data representation and exchange*
- [16] ISO 13584-42, *Industrial automation systems and integration — Parts library — Part 42: Description methodology: Methodology for structuring parts families*
- [17] ISO 25178, *Geometrical product specification (GPS) — Surface texture: Areal*
- [18] ISO 25297-1, *Optics and photonics — Electronic exchange of optical data — Part 1: NODIF information model*
- [19] ISO/TR 14999-2:2005, *Optics and photonics — Interferometric measurement of optical elements and optical systems — Part 2: Measurement and evaluation techniques*
- [20] MALACARA D. Optical Shop Testing. Wiley, Third Edition, 2007

[\(Continued from second cover\)](#)

In this adopted standard, reference appears to the following International Standards for which Indian Standards also exist. The corresponding Indian Standards which are to be substituted in their places are listed below along with their degree of equivalence for the editions indicated:

<i>International Standard</i>	<i>Corresponding Indian Standard</i>	<i>Degree of Equivalence</i>
ISO 1101 Geometrical product specifications (GPS) — Geometrical tolerancing — Tolerances of form, orientation, location and run-out	IS 8000 (Part 1) : 2019/ISO 1101 : 2017 Geometrical product specifications (GPS) — Geometrical tolerancing: Part 1 Tolerances of form, orientation, location and run-out (<i>second revision</i>)	Identical
ISO 5459 Geometrical product specifications (GPS) — Geometrical tolerancing — Datums and datum systems	IS 10721 : 2023/ISO 5459 : 2011 Geometrical product specifications (GPS) — Geometrical tolerancing — Datums and datum systems (<i>first revision</i>)	Identical
ISO 10110-5 Optics and photonics — Preparation of drawings for optical elements and systems — Part 5: Surface form tolerances	IS 5920 (Part 2) : 2024/ISO 10110-5 : 2015 Optics and photonics — Preparation of drawings for optical elements and systems: Part 5 Surface form tolerance	Identical
ISO 10110-6 Optics and photonics — Preparation of drawings for optical elements and systems — Part 6: Centring tolerances	IS 5920 (Part 3) : 2024/ISO 10110-6 : 2015 Optics and photonics — Preparation of drawings for optical elements and systems: Part 6 Centring tolerances	Identical
ISO 10110-7 Optics and photonics — Preparation of drawings for optical elements and systems — Part 7: Surface imperfections	IS 5920 (Part 4) : 2024/ISO 10110-7 : 2017 Optics and photonics — Preparation of drawings for optical elements and systems: Part 7 Surface imperfections	Identical
ISO 10110-8 Optics and photonics — Preparation of drawings for optical elements and systems — Part 8: Surface texture	IS 5920 (Part 5) : 2024/ISO 10110-8 : 2019 Optics and photonics — Preparation of drawings for optical elements and systems: Part 8 Surface texture	Identical
ISO 10110-14 Optics and photonics — Preparation of drawings for optical elements and systems — Part 14: Wave front deformation tolerance	IS 5920 (Part 9) : 2024/ISO 10110-14 : 2018 Optics and photonics — Preparation of drawings for optical elements and systems: Part 14 Wave front deformation tolerance	Identical

Bureau of Indian Standards

BIS is a statutory institution established under the *Bureau of Indian Standards Act, 2016* to promote harmonious development of the activities of standardization, marking and quality certification of goods and attending to connected matters in the country.

Copyright

BIS has the copyright of all its publications. No part of these publications may be reproduced in any form without the prior permission in writing of BIS. This does not preclude the free use, in the course of implementing the standard, of necessary details, such as symbols and sizes, type or grade designations. Enquiries relating to copyright be addressed to the Head (Publication & Sales), BIS.

Review of Indian Standards

Amendments are issued to standards as the need arises on the basis of comments. Standards are also reviewed periodically; a standard along with amendments is reaffirmed when such review indicates that no changes are needed; if the review indicates that changes are needed, it is taken up for revision. Users of Indian Standards should ascertain that they are in possession of the latest amendments or edition by referring to the website-www.bis.gov.in or www.standardsbis.in.

This Indian Standard has been developed from Doc No.: PGD 39 (23515).

Amendments Issued Since Publication

Amend No.	Date of Issue	Text Affected

BUREAU OF INDIAN STANDARDS

Headquarters:

Manak Bhavan, 9 Bahadur Shah Zafar Marg, New Delhi 110002

Telephones: 2323 0131, 2323 3375, 2323 9402

Website: www.bis.gov.in

Regional Offices:

Central : 601/A, Konnectus Tower -1, 6th Floor,
DMRC Building, Bhavbhuti Marg, New
Delhi 110002

Telephones

{ 2323 7617

Eastern : 8th Floor, Plot No 7/7 & 7/8, CP Block, Sector V,
Salt Lake, Kolkata, West Bengal 700091

{ 2367 0012
2320 9474

Northern : Plot No. 4-A, Sector 27-B, Madhya Marg,
Chandigarh 160019

{ 265 9930

Southern : C.I.T. Campus, IV Cross Road, Taramani, Chennai 600113

{ 2254 1442
2254 1216

Western : 5th Floor/MTNL CETTM, Technology Street, Hiranandani Gardens, Powai
Mumbai 400076

{ 25700030
25702715

Branches : AHMEDABAD, BENGALURU, BHOPAL, BHUBANESHWAR, CHANDIGARH, CHENNAI, COIMBATORE, DEHRADUN, DELHI, FARIDABAD, GHAZIABAD, GUWAHATI, HARYANA (CHANDIGARH), HUBLI, HYDERABAD, JAIPUR, JAMMU, JAMSHEDPUR, KOCHI, KOLKATA, LUCKNOW, MADURAI, MUMBAI, NAGPUR, NOIDA, PARWANOO, PATNA, PUNE, RAIPUR, RAJKOT, SURAT, VIJAYAWADA.