

इस्पात के चूड़ीदार बंधकों के लिए
तकनीकी पूर्ति शर्तें

भाग 6 कार्बन इस्पात एवं मिश्र धातु इस्पात के बने
बंधकों के यांत्रिक गुणधर्म — निर्दिष्ट गुणधर्म वर्गों
की ढिबरियाँ

(पाँचवा पुनरीक्षण)

Technical Supply Conditions for
Threaded Steel Fasteners

Part 6 Mechanical Properties of
Fasteners Made of Carbon Steel and
Alloy Steel — Nuts with Specified
Property Classes

(Fifth Revision)

ICS 21.060.20

© BIS 2024

© ISO 2022



भारतीय मानक ब्यूरो
BUREAU OF INDIAN STANDARDS
मानक भवन, 9 बहादुर शाह ज़फर मार्ग, नई दिल्ली - 110002
MANAK BHAVAN, 9 BAHADUR SHAH ZAFAR MARG
NEW DELHI - 110002
www.bis.gov.in www.standardsbis.in

NATIONAL FOREWORD

This Indian Standard (Part 6) (Fifth Revision) which is identical to ISO 898-2 : 2022 'Fasteners — Mechanical properties of fasteners made of carbon steel and alloy steel — Part 2: Nuts with specified property classes' issued by the International Organization for Standardization (ISO) was adopted by the Bureau of Indian Standards on the recommendation of the General Engineering and Fasteners Sectional Committee and after approval of the Production and General Engineering Division Council.

This standard was first published in 1961 and subsequently revised in 1967, 1980, 1994 and 2018. This revision has been brought out to align it with the latest version of ISO 898-2.

The major changes in this revision are as follows:

- a) Property class 9 has been deleted completely, and nuts with fine pitch thread and property class 5 have been deleted (see [Introduction](#));
- b) Nuts with fine pitch thread in style 2 and property class 12 have been added for diameters 18 mm to 39 mm (see [Tables 4, 6 and 10](#));
- c) Styles have been more precisely specified for standard hexagon nuts according to their minimum height, and styles have been specified for other nuts according to their minimum design thread height (see [5.1](#));
- d) Additional statements for thin nuts and jam nuts have been added (see [6](#));
- e) Additional statements for hot dip galvanized nuts have been added by making a reference to IS 1367 (Part 13);
- f) In relation to material, heat treatment and steel microstructure (see [7](#)):
 - 1) The minimum carbon content has been added (see [Tables 3 and 4](#));
 - 2) The minimum manganese content has been specified as 0.25 percent for all non-quenched and tempered nuts (NQT) and has been raised to 0.45 percent for all quenched and tempered nuts (QT) (see [Tables 3 and 4](#));
 - 3) The table footnote for free cutting steel has been reworded (see [Tables 3 and 4](#));
 - 4) The minimum tempering temperature has been added for QT nuts (see [Tables 3 and 4](#) a reference retempering test has been added (see [10.4](#));
 - 5) For nuts that may be optionally quenched and tempered at the manufacturer's discretion;
 - 6) Detailed specifications have been added (see [7.2](#)); and
 - 7) Specifications for steel microstructure have been added for NQT and QT nuts (see [7.4.1, 7.4.2 and 10.3](#));
- g) In relation to proof load:
 - 1) The proof load values for nuts with coarse pitch thread and property classes 6 and 8 have been raised for sizes M27 to M39 (see [Introduction, Table 5, and Annex C](#)); and
 - 2) The maximum hole diameter for the grip has been corrected for diameters 5 mm and 6 mm (see [Table 11](#)), and reference to additional proof load specifications has been added for prevailing torque nuts (see [10.1](#));
- h) In relation to hardness:
 - 1) The reference Vickers hardness values have been recalculated, and conversion into Brinell and Rockwell hardness has been adjusted (see [Introduction and 8.3](#));

- 2) Hardness determined on the bearing surface [see [10.2.4 \(a\)](#)] and hardness determined in the transverse section at mid-height of the nut [see [10.2.4 \(b\)](#)] have been added for routine inspection;
 - 3) The test method for hardness determined in the thread has been improved and the test force has been specified according to the pitch dimension (see [10.2.5](#));
 - 4) For QT nuts, the test methods for hardness in the core (see [10.2.6](#)) and uniformity of hardness (see [10.2.7](#)) have been added; and
 - 5) Requirements for hardness have been clarified (see [10.2.8](#) and [10.2.9](#));
- j) Inspection documents have been referenced in accordance with ISO 16228 for fasteners (see [9.4](#));
 - k) Marking and labelling have been revised, and all nuts conforming to this standard are to be marked whatever their shape (see [11](#));
 - m) [Annex B](#), Design principles for nuts, has been revised; and
 - n) [Annex C](#), Nominal stress under proof load, has been added.

This standard has been published in 18 parts. Other parts in this series are:

Part 1	General requirements for bolts, screws studs and nuts
Part 2	Tolerances for fasteners — Bolts, screws, studs and nuts — Product grades A, B and C
Part 3	Mechanical properties of fasteners made of carbon steel and alloy steel — Bolts screws and studs
Part 5	Mechanical properties of fasteners made of carbon steel and alloy steel — Set screws and similar threaded fasteners with specified hardness classes — Coarse thread and fine pitch thread
Part 7	Mechanical properties and test methods for nuts without specified proof loads
Part 8	Prevailing torque type steel nuts — Mechanical and performance properties
Part 9	Surface discontinuities
Sec 1	Bolts, screws and studs for general applications
Sec 2	Bolts, screws and studs for special applications
Part 10	Surface discontinuities — Nuts
Part 11	Electroplated coatings
Part 12	Phosphate coatings on threaded fasteners
Part 13	Hot-dip galvanized coatings on threaded fasteners
Part 14	Mechanical properties of corrosion-resistant stainless-steel fasteners
Sec 1	Bolts screws and stud Bolts, screws and studs with specified grades and property classes
Sec 2	Nuts with specified grades and property classes
Sec 3	Set screws and similar fasteners not under tensile stress
Sec 4	Tapping screw
Part 16	Designation system for fasteners
Part 17	Inspection sampling and acceptance procedure
Part 18	Packaging
Part 19	Axial load fatigue testing of bolts screws and studs
Part 20	Torsional test and minimum torques for bolts and screws with nominal diameters 1 mm to 10 mm

The text of ISO standard has been approved as suitable for publication as an Indian Standard without deviations. Certain conventions are, however, not identical to those used in Indian Standards. Attention is particularly drawn to the following:

- a) Wherever the words 'International Standard' appear referring to this standard, they should be read as 'Indian Standard'; and
- b) Comma (,) has been used as a decimal marker while in Indian Standards, the current practice is to use a point (.) as the decimal marker.

In this adopted standard, reference appears to certain International Standards for which Indian Standards also exist. The corresponding Indian Standards, which are to be substituted in their respective places, are listed below along with their degree of equivalence for the editions indicated:

<i>International Standard</i>	<i>Corresponding Indian Standard</i>	<i>Degree of Equivalence</i>
ISO 2320 Fasteners — Prevailing torque steel nuts — Functional properties	IS 1367 (Part 8) : 2020/ISO 2320 : 2015 Technical supply conditions for threaded steel fasteners: Part 8 Prevailing torque type steel nuts — Functional properties (<i>fifth revision</i>)	Identical
ISO 6157-2 Fasteners — Surface discontinuities — Part 2: Nuts	IS 1367 (Part 10) : 2002/ISO 6157 : 1995 Technical supply conditions for threaded steel fasteners: Part 10 Surface discontinuities — Nuts (<i>third revision</i>)	Identical
ISO 6506-1 Metallic materials — Brinell hardness test — Part 1: Test method	IS 1500 (Part 1) : 2019/ISO 6506-1 : 2014 Metallic materials — Brinell hardness test: Part 1 Test method (<i>fifth revision</i>)	Identical
ISO 6507-1 Metallic materials — Vickers hardness test — Part 1: Test method	IS 1501 (Part 1) : 2020/ISO 6507-1 : 2018 Metallic materials — Vickers hardness test: Part 1 Test method (<i>fifth revision</i>)	Identical
ISO 6508-1 Metallic materials — Rockwell hardness test — Part 1: Test method	IS 1586 (Part 1) : 2018/ISO 6508-1 : 2016 Metallic materials — Rockwell hardness test: Part 1 Test method (<i>fifth revision</i>)	Identical
ISO 6892-1 Metallic materials — Tensile testing — Part 1: Method of test at room temperature	IS 1608 (Part 1) : 2022/ISO 6892-1 : 2019 Metallic materials — Tensile testing: Part 1 Method of test at room temperature (<i>fifth revision</i>)	Identical
ISO 7500-1 Metallic materials — Calibration and verification of static uniaxial testing machines — Part 1: Tension/compression testing machines — Calibration and verification of the force- measuring system	IS 1828 (Part 1) : 2022/ISO 7500-1 : 2018 Metallic materials — Calibration and verification of static uniaxial testing machines: Part 1 Tension/compression testing machines — Calibration and verification of the force-measuring system (<i>fifth revision</i>)	Identical

<i>International Standard</i>	<i>Corresponding Indian Standard</i>	<i>Degree of Equivalence</i>
ISO 10684 Fasteners — Hot dip galvanized coatings	IS 1367 (Part 13) : 2020/ISO 10684 : 2004 Technical supply conditions for threaded steel fasteners: Part 13 Hot dip galvanized coatings on threaded fasteners (<i>third revision</i>)	Identical

The Committee has reviewed the provisions of the following International Standard referred in this adopted standard and has decided that it is acceptable for use in conjunction with this standard:

<i>International Standard</i>	<i>Title</i>
ISO 1891-4	Fasteners — Vocabulary — Part 4: Control, inspection, delivery, acceptance and quality
ISO 16228	Fasteners — Types of inspection documents

For the purpose of deciding whether a particular requirement of this standard is complied with, the final value, observed or calculated, expressing the result of a test or analysis, shall be rounded off in accordance with IS 2 : 2022 'Rules of rounding off numerical values (*second revision*)'. The number of significant places retained in the rounded off value should be the same as that of the specified value in this standard.

Contents

Page

Introduction	ix
1 Scope	1
2 Normative references	2
3 Terms and definitions	2
4 Symbols	2
5 Designation systems	3
5.1 Nut styles.....	3
5.2 Property classes.....	3
5.2.1 Regular nuts (style 1) and high nuts (style 2).....	3
5.2.2 Thin nuts (style 0).....	4
6 Design of bolt and nut assemblies	4
7 Material, heat treatment, chemical composition and steel microstructure	4
7.1 General.....	4
7.2 Heat treatment.....	5
7.3 Chemical composition.....	5
7.4 Steel microstructure.....	7
7.4.1 Non-quenched and tempered nuts.....	7
7.4.2 Quenched and tempered nuts.....	7
8 Mechanical and physical properties	7
8.1 General.....	7
8.2 Proof load.....	8
8.3 Hardness.....	9
8.4 Surface integrity.....	11
9 Inspection	11
9.1 Manufacturer's inspection.....	11
9.2 Supplier's inspection.....	11
9.3 Purchaser's inspection.....	11
9.4 Delivery of test results.....	12
10 Test methods	12
10.1 Proof load test.....	12
10.1.1 General.....	12
10.1.2 Applicability.....	12
10.1.3 Apparatus.....	12
10.1.4 Testing device.....	12
10.1.5 Test procedure.....	13
10.1.6 Test results and requirements.....	14
10.2 Hardness tests.....	14
10.2.1 General.....	14
10.2.2 Applicability.....	14
10.2.3 Test methods.....	14
10.2.4 Test procedures for routine inspection.....	14
10.2.5 Hardness determined in the thread.....	16
10.2.6 Hardness determined in the core.....	17
10.2.7 Uniformity of hardness for quenched and tempered nuts (QT).....	18
10.2.8 Requirements for non-quenched and tempered nuts (NQT).....	18
10.2.9 Requirements for quenched and tempered nuts (QT).....	18
10.3 Steel microstructure.....	19
10.3.1 General.....	19
10.3.2 Applicability.....	19

10.3.3	Test method	19
10.3.4	Test results and requirements	19
10.4	Retempering test	19
10.4.1	General	19
10.4.2	Test procedure	19
10.4.3	Test results and requirements	20
10.5	Surface discontinuity inspection	20
11	Marking and labelling	20
11.1	General requirements	20
11.2	Property class marking symbols for nuts with full loadability	20
11.3	Property class marking symbols for nuts with reduced loadability	21
11.4	Manufacturer's identification mark	21
11.5	Nut marking	21
11.6	Marking of the packages (labelling)	23
Annex A (normative) Thread dimensions of the test mandrel		25
Annex B (informative) Design principles for nuts		27
Annex C (informative) Stress under proof load, S_p		29
Bibliography		31

Introduction

ISO 898, the basic standard for fasteners with ISO metric thread made of carbon steel and alloy steel, was developed in several parts, and includes diameters 5 mm to 39 mm only for nuts. Property classes are specified in the ISO 898 series in relation to materials and mechanical properties, so that nuts in accordance with ISO 898-2 are matching with bolts, screws and studs specified in ISO 898-1 and with flat washers specified in ISO 898-3, as necessary, in order to design suitable assemblies for a given application.

More parts are under development for bolts, screws, studs and nuts with sizes above 39 mm.

The nuts specified in this document result from the adequate combination of nut heights (regular, style 1 – high, style 2 – thin, style 0), diameter ranges, coarse or fine pitch thread, and property classes in relation to heat treatment (Non-Quenched and Tempered = NQT, or Quenched and Tempered = QT). These combinations are based on bolt/nut compatibility, manufacturing processes and market needs. If other combinations are needed, e.g. for nuts designed for particular applications, see ISO/TR 16224.

In order to assure the necessary material strength in relation to property classes:

- Quenched and Tempered nuts (QT) are specified with a minimum carbon content and a minimum tempering temperature, and are characterized by a homogeneous martensitic structure;
- Non-Quenched and Tempered nuts (NQT) are also specified with a minimum carbon content but are characterized by a non-quenched microstructure.

Some property classes (in relation to nut style, diameter and coarse or fine pitch thread) specified as NQT may be optionally quenched and tempered as specified in [7.2](#), and in this case all requirements for QT nuts apply.

For fully loadable non-standard nuts which are to meet the requirements of this document, the relevant style 1 or style 2 is assigned in relation to their minimum design thread height.

Nut loadability is primarily checked by proof load. For nuts with coarse pitch thread and property classes 6 and 8, proof load values have been raised for sizes M27 to M39 due to the latest calculations of Masaya Hagiwara^[20] in accordance with the Alexander's theory^[21], see ISO/TR 16224. For those nuts it was necessary to develop full strength in relation to the mating bolts, screws and studs specified in ISO 898-1, the difference between the proof loads of ISO 898-2:2012 and the recalculated values being more than 5 % (see [Annex C](#)).

The Vickers hardness values specified for each individual group (consisting of property class, style, diameter range and pitch) have been chosen according to the same latest calculations, but adjusted to conventional figures taken over from the former versions of Parts 2 and 6 which were merged in 2012.

ISO 18265 presents no hardness to tensile strength correlation for steel in work hardened condition, which is typical for cold forged high volume NQT nuts: therefore, minimum hardness is just informative for NQT nuts and does not constitute a criterion in case of dispute. The maximum hardness of 334 HV is specified in order to prevent unexpected manufacturing processes which can lead to brittle behaviour of the NQT nuts: this limit is therefore mandatory and valid in case of dispute. However, it should be noted that work hardening is usually not severe enough to reach 302 HV when typical material and forging processes are used; nevertheless, inappropriate hardness testing or scattering due to just local properties is also covered by this specified limit of 334 HV.

Due to missing or decreasing market needs, nuts of property class 5 with fine pitch thread in style 1 and nuts of property class 9 were deleted (property class 5 or 9 can be substituted by property class 6 or 10 respectively).

Indian Standard

TECHNICAL SUPPLY CONDITIONS FOR THREADED STEEL
FASTENERS

**PART 6 MECHANICAL PROPERTIES OF FASTENERS MADE OF
CARBON STEEL AND ALLOY STEEL — NUTS WITH SPECIFIED
PROPERTY CLASSES**

(*Fifth Revision*)

1 Scope

This document specifies the mechanical and physical properties of nuts made of non-alloy steel or alloy steel, when tested at the ambient temperature range of 10 °C to 35 °C.

This document applies to nuts:

- with ISO metric thread (see ISO 68-1),
- with diameter/pitch combinations according to ISO 261 and ISO 262,
- with coarse pitch thread M5 to M39, and fine pitch thread M8×1 to M39×3,
- with thread tolerances according to ISO 965-1, ISO 965-2 or ISO 965-5,
- with specified property classes 04, 05, 5, 6, 8, 10 and 12 including proof load,
- of three different nut styles (see 5.1): regular nuts (style 1), high nuts (style 2) and thin nuts (style 0),
- with a minimum outside diameter or width across flats $s \geq 1,45D$,
- able to mate with bolts, screws and studs with property classes in accordance with ISO 898-1 (see Annex B), and
- intended to be used in applications ranging from -50 °C to +150 °C, or up to +300 °C.

WARNING — Nuts conforming to the requirements of this document are tested at the ambient temperature range of 10 °C to 35 °C and are used in applications ranging from -50 °C to +150 °C; however, these nuts are also used outside this range and up to +300 °C for specific applications. It is possible that they do not retain the specified mechanical and physical properties at lower and/or elevated temperatures. Therefore, it is the responsibility of the user to determine the appropriate choices based on the service environment conditions of the assembly (see also 7.1).

For additional specifications applicable to hot dip galvanized nuts, see ISO 10684.

For nuts designed for particular applications, see ISO/TR 16224.

This document does not specify requirements for functional properties such as:

- prevailing torque properties (see ISO 2320),
- torque/clamp force properties (see ISO 16047 for test method),
- weldability, or
- corrosion resistance.

2 Normative references

The following documents are referred to in the text in such a way that some or all of their content constitutes requirements of this document. For dated references, only the edition cited applies. For undated references, the latest edition of the referenced document (including any amendments) applies.

ISO 1891-4, *Fasteners — Vocabulary — Part 4: Control, inspection, delivery, acceptance and quality*

ISO 2320, *Fasteners — Prevailing torque steel nuts — Functional properties*

ISO 6157-2, *Fasteners — Surface discontinuities — Part 2: Nuts*

ISO 6506-1, *Metallic materials — Brinell hardness test — Part 1: Test method*

ISO 6507-1, *Metallic materials — Vickers hardness test — Part 1: Test method*

ISO 6508-1, *Metallic materials — Rockwell hardness test — Part 1: Test method*

ISO 6892-1, *Metallic materials — Tensile testing — Part 1: Method of test at room temperature*

ISO 7500-1, *Metallic materials — Calibration and verification of static uniaxial testing machines — Part 1: Tension/compression testing machines — Calibration and verification of the force-measuring system*

ISO 10684, *Fasteners — Hot dip galvanized coatings*

ISO 16228, *Fasteners — Types of inspection documents*

3 Terms and definitions

No terms and definitions are listed in this document.

ISO and IEC maintain terminology databases for use in standardization at the following addresses:

- ISO Online browsing platform: available at <https://www.iso.org/obp>
- IEC Electropedia: available at <https://www.electropedia.org/>

4 Symbols

D	nominal thread diameter of the nut (basic major diameter of the internal thread), mm
d_h	hole diameter of the grip, mm
F	force, N
F_p	proof load, N
h	thickness of the grip, mm
m	height of the nut, mm
$m_{th,design}$	design thread height of the nut, mm
P	pitch of the thread, mm
s	width across flats, mm
S_p	stress under proof load, MPa

5 Designation systems

5.1 Nut styles

This document specifies three styles for nuts.

For standard hexagon nuts without flange and without prevailing torque feature, the following limits apply:

- style 1: regular nut with minimum height $0,80D \leq m_{\min} < 0,89D$, see [Table B.1](#);
- style 2: high nut with minimum height $m_{\min} \geq 0,89D$, see [Table B.1](#);
- style 0: thin nut with minimum height $0,45D \leq m_{\min} < 0,80D$.

For other standard nuts (e.g. nuts with flange, prevailing torque nuts, non-hexagon nuts, etc.), the style shall be addressed in the product standard together with the mechanical properties.

For nuts per drawing, the style shall be addressed in accordance with the minimum design thread height, $m_{\text{th,design}}$, together with the mechanical properties. $m_{\text{th,design}}$ is specified in [Figure 1](#) and [Table 1](#). $m_{\text{th,design}}$ is the distance between the intersections of the nut chamfer(s) if any or the nut face(s), with the theoretical cylinder representing the nominal thread diameter D .

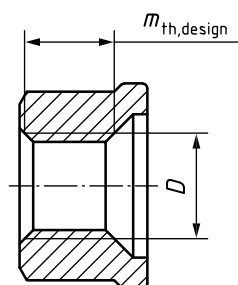

Figure 1 — Design thread height, $m_{\text{th,design}}$

Table 1 — Design thread height for nuts per drawing

Regular nuts (style 1)	High nuts (style 2)	Thin nuts (style 0)
$0,73D \leq m_{\text{th,design,min}} < 0,83D$	$m_{\text{th,design,min}} \geq 0,83D$	$0,40D \leq m_{\text{th,design,min}} < 0,73D$
NOTE 1 Limits for $m_{\text{th,design,min}}$ are calculated by taking into account the most critical dimensions for the nuts, i.e. minimum height m_{\min} , maximum diameter of the countersink $d_{\text{a,max}}$, minimum countersink angle for the chamfer (90° for regular and high nuts, 110° for thin nuts) and two chamfers (one on each bearing face).		
NOTE 2 The resulting minimum ratios for standard hexagon nuts with diameters 12 mm to 39 mm are the basis for the figures specified in this Table.		

5.2 Property classes

5.2.1 Regular nuts (style 1) and high nuts (style 2)

The property classes of regular nuts (style 1) and high nuts (style 2) consist of a number. This number corresponds to the left number of the appropriate highest property class of bolts, screws and studs with which they can be mated, which is 1/100 of the nominal tensile strength of the mating bolt in megapascals.

EXAMPLE Nut with property class 10 is a regular or high nut to be mated with a bolt of property class up to 10.9 included.

5.2.2 Thin nuts (style 0)

The property classes of thin nuts (style 0) consist of two digits, specified in the following way:

- a) the first digit "zero" indicates the reduced loadability of thin nuts, in order to warn that these nuts are not designed to prevent thread stripping failure mode in case of overloading;
- b) the second digit corresponds to approximately 1/100 of the nominal stress under proof load, S_p , in megapascals (MPa).

EXAMPLE Nut with property class 05 is a thin nut with a nominal stress under proof load of 500 MPa.

6 Design of bolt and nut assemblies

Explanations of basic design principles of nuts and loadability of bolted assemblies are given in [Annex B](#). Information for nominal stress under proof load S_p is given in [Annex C](#).

Regular nuts (style 1) and high nuts (style 2) shall be mated with externally threaded fasteners in accordance with [Table 2](#). However, nuts of a higher property class may replace nuts of a lower property class, except for prevailing torque nuts where only nuts and externally threaded fasteners with corresponding property classes shall be combined.

Table 2 — Combination of regular nuts (style 1) and high nuts (style 2) with bolt, screw, stud property classes

Nut property class	Highest property class of mating bolt, screw and stud
5	5.8
6	6.8
8	8.8
10	10.9
12	12.9/12.9

Thin nuts (style 0) have a reduced loadability compared to regular nuts or high nuts and are not designed to prevent thread stripping failure mode in case of overloading.

Thin nuts used as jam nuts shall be assembled together with a regular nut or a high nut (thin nuts of property class 04 with regular or high nuts up to and including property class 8, thin nuts of property class 05 with regular or high nuts of property class up to and including 12).

7 Material, heat treatment, chemical composition and steel microstructure

7.1 General

When tested at ambient temperature by the methods specified in [Clause 10](#), nuts with specified property class shall meet the requirements specified in [Clause 7](#), regardless of which tests are performed during manufacture or final inspection.

When nuts are intended to be used in applications outside the range of -50 °C to $+150\text{ °C}$, several factors need to be taken into account, e.g. steel composition, duration of exposure at low or elevated temperature, the effect of the temperature on the fastener mechanical properties and clamped parts.

NOTE Information for the selection and application of steels for use at lower and elevated temperatures is given for instance in EN 10269, ASTM A320/A320M and ASTM A194/A194M.

The chemical composition limits of steels, the heat treatment condition (including minimum tempering temperature for quenched and tempered nuts only) and microstructure for the specified combinations

of property classes, heights (styles) and thread diameters shall be in accordance with [Table 3](#) for nuts with coarse pitch thread, and with [Table 4](#) for nuts with fine pitch thread.

7.2 Heat treatment

Nuts shall be manufactured in accordance with the requirements specified in [Tables 3](#) and [4](#) for the following heat treatment conditions:

- Not Quenched and Tempered (NQT),
- Quenched and Tempered (QT).

Only the following nuts are allowed to be manufactured in one or the other condition (NQT or QT) at the manufacturer's discretion, and in both cases these nuts shall meet all applicable requirements for the relevant heat treatment condition:

- a) For nuts with coarse pitch thread and in accordance with [Table 3](#):
 - regular nuts (style 1) of property class 8 with $D \leq M16$,
 - high nuts (style 2) of property class 8;
- b) For nuts with fine pitch thread and in accordance with [Table 4](#):
 - regular nuts (style 1) of property class 6 with $D \leq 16$ mm,
 - high nuts (style 2) of property class 8 with $D \leq 16$ mm.

7.3 Chemical composition

The chemical composition shall be assessed in accordance with the relevant International Standards. In case of dispute, the product analysis shall meet the limits specified in [Table 3](#) or [4](#).

For nuts that are to be hot dip galvanized, the additional requirements specified in ISO 10684 shall apply.

Table 3 — Chemical composition limits of steels for nuts with coarse pitch thread

Heat treatment	Property class	Nut height	Thread <i>D</i>	Cast analysis ^{a,b}					Tempering temperature °C min.
				C %		Mn	P	S	
				min.	max.	min.	max.	max.	
Not Quenched and Tempered (NQT) ^c	04 ^d	Style 0	$M5 \leq D \leq M39$	0,06	0,58	0,25	0,060	0,150	—
	5 ^d	Style 1	$M5 \leq D \leq M39$						
	6 ^d	Style 1	$M5 \leq D \leq M39$						
	8	Style 1	$M5 \leq D \leq M16$ ^e						
		Style 2	$M5 \leq D \leq M39$ ^e						
Quenched and Tempered (QT) ^f	05	Style 0	$M5 \leq D \leq M39$	0,15	0,58	0,45	0,048	0,058	380
	8	Style 1	$M5 \leq D \leq M39$						
		Style 2	$M5 \leq D \leq M39$						
	10	Style 1	$M5 \leq D \leq M39$						
		Style 2	$M5 \leq D \leq M39$						
	12	Style 1	$M5 \leq D \leq M16$	0,18					410
		Style 2	$M5 \leq D \leq M39$	0,15					380

^a In case of dispute, product analysis shall apply.

^b Alloying elements may be added, provided the mechanical and physical properties required in [Clause 8](#) are met.

^c The steel structure of NQT nuts shall not consist of quenched microstructure, in accordance with [7.4.1](#).

^d These nuts may be manufactured from free cutting steel containing sulfur, phosphorus and lead, with the following contents: S ≤ 0,350 %; P ≤ 0,110 %; Pb ≤ 0,350 %.

^e These nuts may be quenched and tempered at the manufacturer's discretion, and in this case all requirements for QT nuts shall apply.

^f The microstructure of QT nuts shall show approximately 90 % martensite in accordance with [7.4.2](#).

Table 4 — Chemical composition limits of steels for nuts with fine pitch thread

Heat treatment	Property class	Nut height	Thread D	Cast analysis ^{a,b}					Tempering temperature °C min.
				C %		Mn	P	S	
				min.	max.	min.	max.	max.	
Not Quenched and Tempered (NQT) ^c	04 ^d	Style 0	$8 \text{ mm} \leq D \leq 39 \text{ mm}$	0,06	0,58	0,25	0,060	0,150	—
	6 ^d	Style 1	$8 \text{ mm} \leq D \leq 16 \text{ mm}$ ^e						
	8	Style 2	$8 \text{ mm} \leq D \leq 16 \text{ mm}$ ^e						
Quenched and Tempered (QT) ^f	05	Style 0	$8 \text{ mm} \leq D \leq 39 \text{ mm}$	0,15	0,58	0,45	0,048	0,058	380
	6	Style 1	$8 \text{ mm} \leq D \leq 39 \text{ mm}$						
	8	Style 1	$8 \text{ mm} \leq D \leq 16 \text{ mm}$	0,18					
		Style 1	$16 \text{ mm} < D \leq 39 \text{ mm}$						
	10	Style 2	$8 \text{ mm} \leq D \leq 39 \text{ mm}$	0,15					
		Style 1	$8 \text{ mm} \leq D \leq 16 \text{ mm}$						
	12	Style 2	$8 \text{ mm} \leq D \leq 39 \text{ mm}$	0,18					410

^a In case of dispute, product analysis applies.
^b Alloying elements may be added, provided the mechanical and physical properties required in [Clause 8](#) are met.
^c The steel structure of NQT nuts shall not consist of quenched microstructure, in accordance with [7.4.1](#).
^d These nuts may be manufactured from free cutting steel containing sulfur, phosphorus and lead, with the following contents: S \leq 0,350 %; P \leq 0,110 %; Pb \leq 0,350 %.
^e These nuts may be quenched and tempered at the manufacturer's discretion, and in this case all requirements for QT nuts shall apply.
^f The microstructure of QT nuts shall show approximately 90 % martensite in accordance with [7.4.2](#).

7.4 Steel microstructure

7.4.1 Non-quenched and tempered nuts

Nuts that are non-quenched and tempered (NQT) shall be supplied in the as forged or machined condition. The steel structure shall not consist of quenched microstructure.

7.4.2 Quenched and tempered nuts

For materials of nuts to be quenched and tempered (QT), there shall be a sufficient hardenability to ensure a homogenous microstructure consisting of approximately 90 % martensite throughout the nuts.

The manufacturer shall ensure that the austenite transformation temperature has been exceeded and sufficient duration allowed to achieve adequate transformation to martensite throughout the nut during quenching to ensure uniform mechanical properties.

8 Mechanical and physical properties

8.1 General

When tested at ambient temperature by the methods specified in [Clause 10](#), nuts with specified property class shall meet the mechanical and physical requirements specified in [Clause 8](#), regardless of which tests are performed during manufacture or final inspection.

8.2 Proof load

When tested in accordance with 10.1, nuts with specified property class shall meet the requirements for the proof load specified in Table 5 or 6.

Table 5 — Proof loads for nuts with coarse pitch thread

Thread <i>D</i>	Pitch <i>P</i>	Proof load, F_p (N)						
		Property class						
		04 ^a	05 ^a	5	6	8	10	12
M5	0,8	5 400	7 100	8 250	9 500	12 140	14 800	16 300
M6	1	7 640	10 000	11 700	13 500	17 200	20 900	23 100
M7	1	11 000	14 500	16 800	19 400	24 700	30 100	33 200
M8^b	1,25	13 900	18 300	21 600	24 900	31 800	38 100	42 500
M10^b	1,5	22 000	29 000	34 200	39 400	50 500	60 300	67 300
M12	1,75	32 000	42 200	51 400	59 000	74 200	88 500	100 300
M14	2	43 700	57 500	70 200	80 500	101 200	120 800	136 900
M16	2	59 700	78 500	95 800	109 900	138 200	164 900	186 800
M18	2,5	73 000	96 000	121 000	138 200	176 600	203 500	230 400
M20	2,5	93 100	122 500	154 400	176 400	225 400	259 700	294 000
M22	2,5	115 100	151 500	190 900	218 200	278 800	321 200	363 600
M24	3	134 100	176 500	222 400	254 200	324 800	374 200	423 600
M27	3	174 400	229 500	289 200	348 800	452 100	486 500	550 800
M30	3,5	213 200	280 500	353 400	426 400	552 600	594 700	673 200
M33	3,5	263 700	347 000	437 200	527 400	683 600	735 600	832 800
M36	4	310 500	408 500	514 700	620 900	804 700	866 000	980 400
M39	4	370 900	488 000	614 900	741 800	961 400	1 035 000	1 171 000

^a When thin nuts are used, the application shall take into account the stripping load which is lower than the proof load of a nut with full loadability (see Annex B).

^b Hot dip galvanized nuts with thread tolerance class 6H shall meet the requirements of this Table. For hot dip galvanized nuts with thread tolerance classes 6AX and 6AZ in accordance with ISO 965-5, the lower proof loads specified in ISO 10684 for M8 and M10 shall apply.

Table 6 — Proof loads for nuts with fine pitch thread

Thread <i>D</i> × <i>P</i>	Proof load, F_p (N)					
	Property class					
	04 ^a	05 ^a	6	8	10	12
M8×1	14 900	19 600	30 200	37 400	43 100	47 000
M10×1,25	23 300	30 600	47 100	58 400	67 300	73 400
M10×1	24 500	32 200	49 700	61 600	71 000	77 400
M12×1,5	33 500	44 000	68 700	84 100	97 800	105 700
M12×1,25	35 000	46 000	71 800	88 000	102 200	110 500
M14×1,5	47 500	62 500	97 500	119 400	138 800	150 000
M16×1,5	63 500	83 500	130 300	159 500	185 400	200 400
M18×2	77 500	102 000	177 500	210 100	220 300	248 100
M18×1,5	81 700	107 500	187 000	221 500	232 200	262 800
M20×2	98 000	129 000	224 500	265 700	278 600	313 500
M20×1,5	103 400	136 000	236 600	280 200	293 800	329 900
M22×2	120 800	159 000	276 700	327 500	343 400	386 500
M22×1,5	126 500	166 500	289 700	343 000	359 600	404 700
M24×2	145 900	192 000	334 100	395 500	414 700	467 100
M27×2	188 500	248 000	431 500	510 900	535 700	609 800
M30×2	236 000	310 500	540 300	639 600	670 700	764 100
M33×2	289 200	380 500	662 100	783 800	821 900	935 800
M36×3	328 700	432 500	804 400	942 800	934 200	1 063 900
M39×3	391 400	515 000	957 900	1 123 000	1 112 000	1 265 000

^a When thin nuts are used, the application shall take into account the stripping load which is lower than the proof load of a nut with full loadability (see [Annex B](#)).

8.3 Hardness

When tested in accordance with [10.2](#), nuts with specified property class shall meet the requirements for the hardness, as follows:

- for NQT nuts the minimum hardness is given for information only but the maximum hardness requirement of [Table 7](#) or [9](#) shall apply;
- for QT nuts the minimum hardness and the maximum hardness requirements of [Table 8](#) or [10](#) shall apply; the difference in hardness determined in the core and in the thread in accordance with [10.2.7](#) shall not be greater than 30 HV.

Table 7 — Hardness for non-quenched and tempered nuts (NQT) with coarse pitch thread

Property class	Style	Thread <i>D</i>	Vickers hardness HV		Converted Brinell hardness ^a HB or HBW		Converted Rockwell hardness ^a	
			min.	max.	min.	max.	min.	max.
04	Style 0	$M5 \leq D \leq M39$	188	334	179	318	88,8 HRB	33,9 HRC
5	Style 1	$M5 \leq D \leq M16$	130		124		71,2 HRB	
		$M16 < D \leq M39$	146		139		77,9 HRB	
6	Style 1	$M5 \leq D \leq M16$	150		143		78,7 HRB	
		$M16 < D \leq M39$	170		162		85,0 HRB	
8	Style 1	$M5 \leq D \leq M16^b$	200		190		91,5 HRB	
	Style 2	$M5 \leq D \leq M39^b$						

^a Brinell and Rockwell hardness are converted from HV values according to ISO 18265 (unalloyed and low alloy steel conditions).

^b These nuts may be quenched and tempered at manufacturer's discretion: in this case, [Table 8](#) shall apply.

Table 8 — Hardness for quenched and tempered nuts (QT) with coarse pitch thread

Property class	Style	Thread <i>D</i>	Vickers hardness HV		Converted Brinell hardness ^a HB or HBW		Converted Rockwell hardness ^a	
			min.	max.	min.	max.	min.	max.
05	Style 0	$M5 \leq D \leq M39$	272	353	268	349	26,5 HRC	36,9 HRC
8	Style 1	$M5 \leq D \leq M16$	200	334	195 ^b	330	92,7 HRB ^b	34,8 HRC
		$M16 < D \leq M39$	233		228		98,9 HRB	
	Style 2	$M5 \leq D \leq M39$	200		195 ^b		92,7 HRB ^b	
10	Style 1	$M5 \leq D \leq M39$	272	353	268	349	26,5 HRC	36,9 HRC
	Style 2	$M5 \leq D \leq M39$	233		228		98,9 HRB	
12	Style 1	$M5 \leq D \leq M16$	308	368	304	363	31,6 HRC	38,5 HRC
	Style 2	$M5 \leq D \leq M39$	272	353	268	349	26,5 HRC	36,9 HRC

^a Brinell and Rockwell hardness are converted from HV values according to ISO 18265 (quenched and tempered condition).

^b Extrapolated value (no conversion available in ISO 18265 for values less than 210 HV).

Table 9 — Hardness for non-quenched and tempered nuts (NQT) with fine pitch thread

Property class	Style	Thread <i>D</i>	Vickers hardness HV		Converted Brinell hardness ^a HB or HBW		Converted Rockwell hardness ^a	
			min.	max.	min.	max.	min.	max.
04	Style 0	$8 \text{ mm} \leq D \leq 39 \text{ mm}$	188	334	179	318	88,8 HRB	33,9 HRC
6	Style 1	$8 \text{ mm} \leq D \leq 16 \text{ mm}^b$	200		190		91,5 HRB	
8	Style 2	$8 \text{ mm} \leq D \leq 16 \text{ mm}^b$	223		212		95,4 HRB	

^a Brinell and Rockwell hardness are converted from HV values according to ISO 18265 (unalloyed and low alloy steel conditions).

^b These nuts may be quenched and tempered at manufacturer's discretion: in this case, [Table 10](#) shall apply.

Table 10 — Hardness for quenched and tempered nuts (QT) with fine pitch thread

Property class	Style	Thread D	Vickers hardness HV		Converted Brinell hardness ^a HB or HBW		Converted Rockwell hardness ^a	
			min.	max.	min.	max.	min.	max.
05	Style 0	$8 \text{ mm} \leq D \leq 39 \text{ mm}$	272	353	268	349	26,5 HRC	36,9 HRC
6	Style 1	$8 \text{ mm} \leq D \leq 16 \text{ mm}$	200	334	195 ^b	330	92,7 HRB ^b	34,8 HRC
		$16 \text{ mm} < D \leq 39 \text{ mm}$	233	334	228	330	98,9 HRB	34,8 HRC
8	Style 1	$8 \text{ mm} \leq D \leq 16 \text{ mm}$	262	334	258	330	24,9 HRC	34,8 HRC
		$16 \text{ mm} < D \leq 39 \text{ mm}$	295	353	291	349	29,8 HRC	36,9 HRC
	Style 2	$8 \text{ mm} \leq D \leq 16 \text{ mm}$	223	334	218	330	97,2 HRB	34,8 HRC
		$16 \text{ mm} < D \leq 39 \text{ mm}$	244	334	239	330	21,9 HRC	34,8 HRC
10	Style 1	$8 \text{ mm} \leq D \leq 16 \text{ mm}$	320	380	316	375	33,1 HRC	39,6 HRC
	Style 2	$8 \text{ mm} \leq D \leq 39 \text{ mm}$	272	353	268	349	26,5 HRC	36,9 HRC
12	Style 2	$8 \text{ mm} \leq D \leq 39 \text{ mm}$	308	368	304	363	31,6 HRC	38,5 HRC

^a Brinell and Rockwell hardness are converted from HV values according to ISO 18265 (quenched and tempered condition).

^b Extrapolated value (no conversion available in ISO 18265 for values less than 210 HV).

8.4 Surface integrity

Surface integrity shall be in accordance with ISO 6157-2.

9 Inspection

9.1 Manufacturer's inspection

This document does not mandate which of the tests the manufacturer shall perform on each manufacturing lot. It is the responsibility of the manufacturer to apply suitable methods of their choice, such as in-process control or final inspection, to ensure that the manufactured lot does conform to all specified requirements. For additional information, see ISO 16426.

In case of dispute, all applicable test methods in accordance with [Clause 10](#) (except hardness routine tests given in [10.2.4](#)) shall apply.

9.2 Supplier's inspection

The supplier may test the nuts which they provide using methods of their choice (periodic evaluation of the manufacturer, checking of test results from the manufacturer, tests on the nuts themselves, etc.), provided all specified requirements are met.

In case of dispute, all applicable test methods in accordance with [Clause 10](#) (except hardness routine tests of [10.2.4](#)) shall apply.

9.3 Purchaser's inspection

The purchaser may test the delivered nuts using the test methods specified in [Clause 10](#).

In case of dispute, all applicable test methods in accordance with [Clause 10](#) (except hardness routine tests given in [10.2.4](#)) shall apply.

9.4 Delivery of test results

If the purchaser requires test results from the supplier, the type of test report shall be agreed upon at the time of the order. It shall be established in accordance with ISO 16228, unless otherwise agreed. Any additional or specific test shall also be specified by the purchaser and agreed upon before the order.

For nuts which are optionally quenched and tempered in accordance with [7.2](#), the heat treatment option (QT or NQT) shall be included in the test report.

10 Test methods

10.1 Proof load test

10.1.1 General

The proof load test consists of two main operations, namely:

- a) application of a specified proof load by means of a test mandrel (see [Figure 2](#)), and
- b) checking of the damage to the nut thread caused by the proof load, if any.

For proof load testing of prevailing torque nuts, the additional test procedure and requirements specified in ISO 2320 shall apply.

10.1.2 Applicability

This test applies to nuts of all sizes and for all property classes.

10.1.3 Apparatus

The tensile testing machine shall be in accordance with ISO 7500-1, class 1 or better. Side thrust on the nut shall be avoided, e.g. by self-aligning grips.

10.1.4 Testing device

The grip and test mandrel shall fulfil the following requirements:

- hardness of the grip: 45 HRC minimum,
- thickness of the grip, h : $1D$ minimum,
- hole diameter of the grip, d_h : in accordance with [Table 11](#),
- mandrel hardened and tempered: hardness 45 HRC to 50 HRC,
- thread tolerance class of the test mandrel: 5h6g, and additionally the tolerance of the major diameter shall be the lowest quarter of the 6g range; thread dimensions for the test mandrel shall be as specified in [Annex A](#).

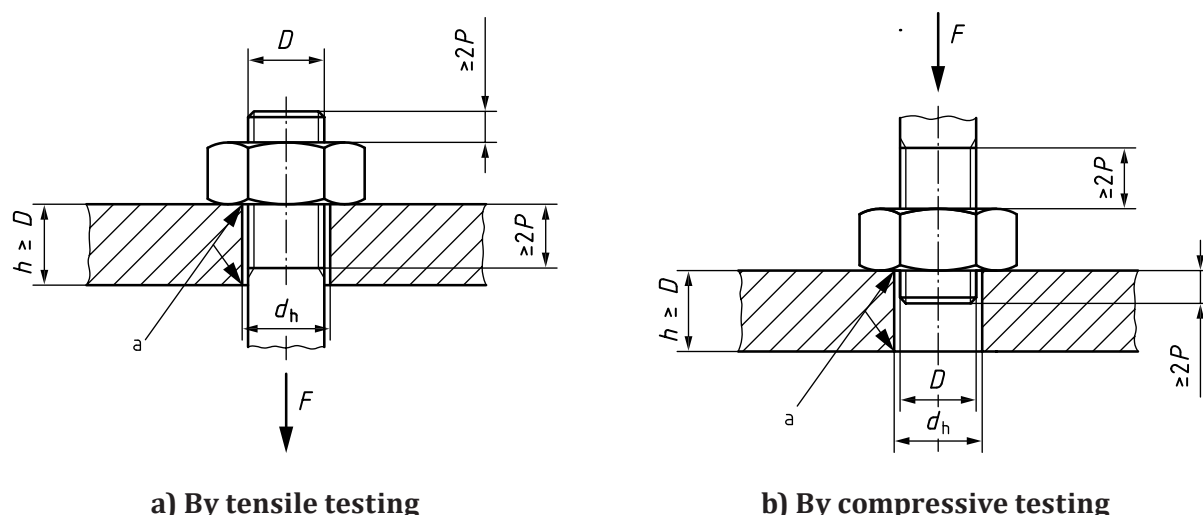

^a No sharp edge.

Figure 2 — Proof load test

Table 11 — Hole diameter for the grip

Dimensions in millimeters

Thread D	Hole diameter d_h^a		Thread D	Hole diameter d_h^a		Thread D	Hole diameter d_h^a	
	min.	max.		min.	max.		min.	max.
5	5,030	5,105	14	14,050	14,160	27	27,065	27,195
6	6,030	6,105	16	16,050	16,160	30	30,065	30,195
7	7,040	7,130	18	18,050	18,160	33	33,080	33,240
8	8,040	8,130	20	20,065	20,195	36	36,080	36,240
10	10,040	10,130	22	22,065	22,195	39	39,080	39,240
12	12,050	12,160	24	24,065	24,195	—	—	—

^a $d_h = D$ with tolerance class D11 (see ISO 286-2).

10.1.5 Test procedure

The nut shall be tested as received.

The thread of the test mandrel shall be checked before and after each test. If the thread of the test mandrel is damaged during the test, the test result shall be discarded and a new test shall be carried out with a conforming mandrel.

The nut shall be assembled on the test mandrel in accordance with [Figure 2](#).

The axial tensile test or axial compressive test shall be carried out in accordance with ISO 6892-1. The speed of testing, as determined with a free-running cross-head, shall not exceed 10 mm/min up to 50 % of the proof load F_p and 3 mm/min beyond.

The proof load specified in [Table 5](#) for nuts with coarse pitch thread and in [Table 6](#) for nuts with fine pitch thread shall be applied, however exceeding the proof load value shall be minimized. The proof load shall be maintained for 15 seconds, and then released.

The nut shall be removed using the fingers from the test mandrel. It can be necessary to use a manual wrench to start the nut in motion, but the use of such a wrench is permissible only to a half turn.

10.1.6 Test results and requirements

The nut shall resist the proof load specified in [Table 5](#) or [6](#) without failing, i.e. without significant plastic deformation, thread stripping, cracking or fracture.

Nuts without prevailing torque feature shall be removable using the fingers after the release of the proof load (and, if necessary, after a half turn maximum with a wrench).

Failure mode and the use of a wrench shall be documented in the test result.

In case of dispute, the tensile proof load test in accordance with [Figure 2](#) a) shall be the reference test method for acceptance.

10.2 Hardness tests

10.2.1 General

Hardness test procedures are specified in [10.2.4](#) to [10.2.7](#).

Optional routine inspection described in [10.2.4](#) may be carried out to monitor the nut manufacturing process.

In case of dispute, only the hardness test procedures specified in [10.2.5](#) to [10.2.7](#) shall apply. Hardness requirements for acceptance of nuts are specified in [10.2.8](#) for non-quenched and tempered nuts (NQT), and in [10.2.9](#) for quenched and tempered nuts (QT). [Table 12](#) summarizes hardness requirements for nuts.

Table 12 — Summary of hardness requirements

Subclause	Characteristic	Requirement for NQT nuts (10.2.8)	Requirement for QT nuts (10.2.9)
10.2.4	Routine tests for hardness	Not valid in case of dispute	
10.2.5	Hardness in the thread	Maximum hardness in accordance with Table 7 or 9	Minimum and maximum hardness in accordance with Table 8 or 10
10.2.6	Hardness in the core	Maximum hardness in accordance with Table 7 or 9	Minimum and maximum hardness in accordance with Table 8 or 10
10.2.7	Uniformity of hardness	No requirement	Difference in hardness in the core and hardness in the thread ≤ 30 HV

10.2.2 Applicability

Hardness tests apply to nuts of all sizes and for all property classes.

10.2.3 Test methods

Hardness shall be determined using the Vickers hardness test in accordance with ISO 6507-1, the Brinell hardness test in accordance with ISO 6506-1, or the Rockwell hardness test in accordance with ISO 6508-1.

10.2.4 Test procedures for routine inspection

These test procedures may be used for routine inspection only.

a) Hardness determined on the bearing surface

The hardness may be determined on one bearing surface of the nut, after removal of any coating and after suitable preparation of the nut. Any appropriate hardness test method can be used. The hardness readings should be located about 120° apart (see [Figure 3](#)).

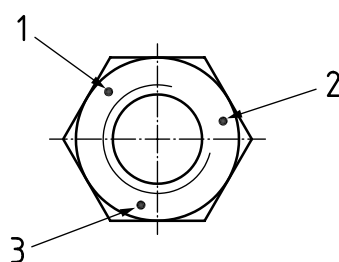

Key

1, 2, 3 position of the hardness readings

Figure 3 — Example of hardness determination on the bearing surface

Following test forces/scales may be used:

- Vickers hardness test: 98 N minimum (HV 10);
- Brinell hardness test: HBW 2,5/187,5;
- Rockwell hardness test: HRB or HRC.

b) Hardness determined on the transverse section

Hardness may be determined on the transverse section through the mid-thread height of the nut. This section should be made with a suitable process where hardness is not altered by excessive heating or work hardening, and the surface should be suitably prepared. Any appropriate hardness test method can be used. Two sets of three readings should be taken along the width across corners and located about 180° apart (see [Figure 4](#)).

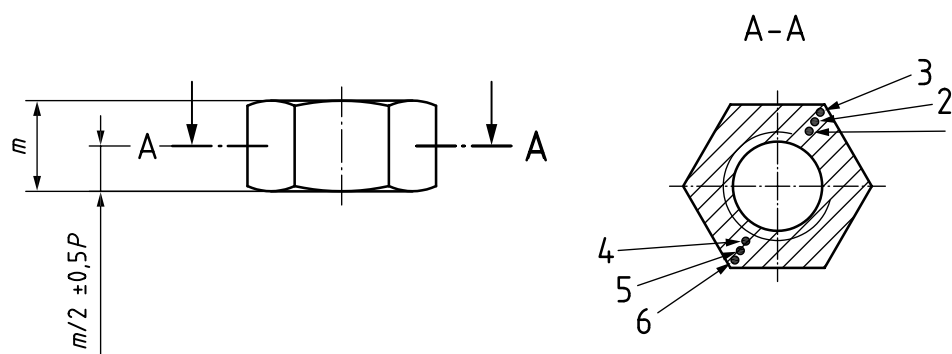

Key

- 1, 4 position of the hardness readings (next to the thread)
- 2, 5 position of the hardness readings (core)
- 3, 6 position of the hardness readings (next to the corner)

Figure 4 — Hardness determination on the transverse section

Following test forces/scales may be used:

- Vickers hardness test: 98 N minimum (HV 10);
- Brinell hardness test: HBW 2,5/187,5;
- Rockwell hardness test: HRB or HRC.

c) Alternative test methods used for production control

Hardness test procedures specified in [10.2.5](#) and [10.2.6](#) may also be used for production control, with any of the test methods (Vickers, Brinell or Rockwell) specified in [10.2.3](#). Care shall be taken that the minimum distance to any edge is in accordance with the relevant hardness standard.

10.2.5 Hardness determined in the thread

Nuts shall be tested as received.

A longitudinal section shall be made through the axis and width across corners, with a suitable process where hardness is not altered by excessive heating or work hardening, and the surface shall be suitably prepared. Vickers hardness with test force in accordance with [Table 13](#) shall be used.

Table 13 — Selection of appropriate test force for Vickers hardness test

Pitch of the nut thread mm	Hardness test symbol
0,8 to 1,75	HV 1
2 to 4	HV 5

NOTE Vickers test force selection is based on the dimensions of the basic profile of ISO metric thread and on the minimum hardness requirement for nuts.

The hardness shall be determined by taking three readings at three pitches, located at the major diameter of the nut thread D and at mid-thread height of the nut (see points 1, 2 and 3 in [Figure 5](#)).

The hardness value in the thread shall be the average of these three readings.

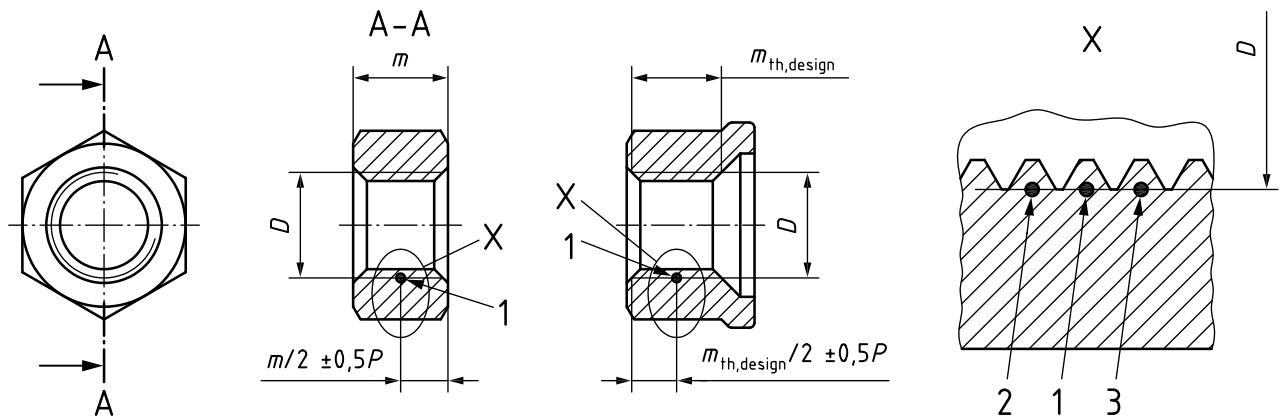

a) Regular or high nut (style 1 or 2)

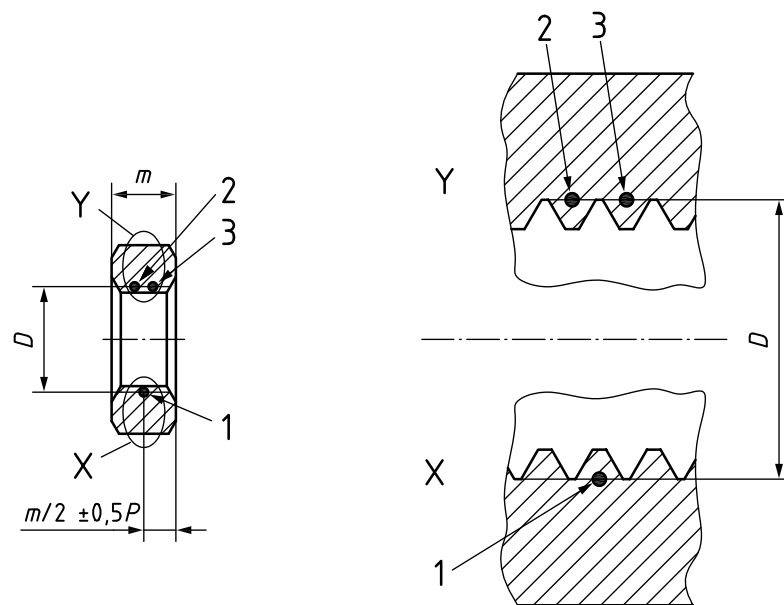

b) Thin nut (style 0)

Key

- 1, 2, 3 hardness readings
- D major thread diameter

Figure 5 — Hardness determination in the thread

10.2.6 Hardness determined in the core

Nuts shall be tested as received.

Hardness in the core shall be determined on a longitudinal section through the axis and width across corners in accordance with [Figure 6](#). This section shall be made with a suitable process where hardness is not altered by excessive heating or work hardening, and the surface shall be suitably prepared. Hardness test shall be performed using HV 10.

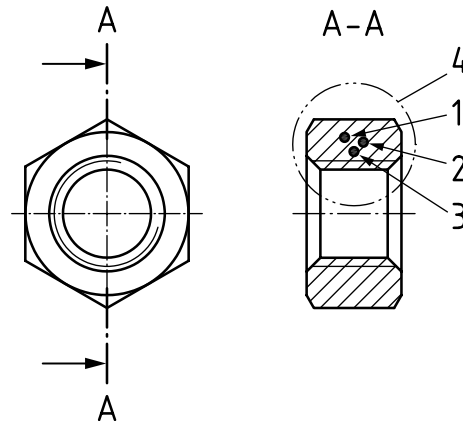

Key

- 1, 2, 3 position of the hardness readings for hardness determination in the core
- 4 area for microstructure evaluation in accordance with [10.3](#)

Figure 6 — Hardness determination in the core

Three readings in the middle of the core shall be taken (see points 1, 2 and 3 in [Figure 6](#)). The hardness value in the core shall be the average of these three readings.

10.2.7 Uniformity of hardness for quenched and tempered nuts (QT)

Nuts shall be tested as received.

Uniformity of hardness for quenched and tempered nuts shall be determined by comparing hardness in the thread as determined in [10.2.5](#) and hardness in the core as determined in [10.2.6](#).

For the proper comparison of hardness in the core with hardness in the thread, hardness test forces for both tests shall be in accordance with [Table 13](#).

10.2.8 Requirements for non-quenched and tempered nuts (NQT)

Not achieving the minimum hardness shall not be cause of rejection provided the proof load requirements in accordance with [10.1.6](#) are met.

The maximum hardness in the thread determined in accordance with [10.2.5](#) shall meet the requirements specified in [Table 7](#) or [9](#).

The maximum hardness in the core determined in accordance with [10.2.6](#) shall meet the requirements specified in [Table 7](#) or [9](#).

10.2.9 Requirements for quenched and tempered nuts (QT)

The hardness in the thread determined in accordance with [10.2.5](#) shall meet the requirements specified in [Table 8](#) or [10](#).

The hardness in the core determined in accordance with [10.2.6](#) shall meet the requirements specified in [Table 8](#) or [10](#).

The difference in hardness in the core and in the thread, determined in accordance with [10.2.7](#), shall not be greater than 30 HV, as specified in [8.3](#).

10.3 Steel microstructure

10.3.1 General

The purpose of the control of the steel microstructure is to ensure that:

- non-quenched and tempered nuts (NQT) have a non-quenched microstructure as specified in [7.4.1](#),
- quenched and tempered nuts (QT) have a uniform martensitic microstructure as specified in [7.4.2](#).

10.3.2 Applicability

This test applies to nuts of all sizes and for all property classes.

10.3.3 Test method

The nut shall be tested as received. Before sample preparation, removal of any coating is recommended.

The microstructure shall be evaluated by an optical microscope on the entire nut section through the width across corners, in accordance with [10.2.6](#) and [Figure 6](#) (Key 4).

10.3.4 Test results and requirements

For non-quenched and tempered nuts (NQT), the requirement for the microstructure specified in [7.4.1](#) shall be met.

For quenched and tempered nuts (QT), the requirement of approximately 90 % martensite specified in [7.4.2](#) shall be met.

10.4 Retempering test

10.4.1 General

The purpose of this test is to check that the minimum tempering temperature has been achieved.

This test applies to nuts having the following specifications:

- all sizes,
- all quenched and tempered nuts (whether they are mandatorily or optionally quenched and tempered).

This test shall be applied only in case of dispute.

10.4.2 Test procedure

The nut shall be tested as received.

A longitudinal section shall be made through the nut axis, with a suitable process where hardness is not altered by excessive heating or work hardening, and the surface shall be suitably prepared. The Vickers hardness shall be determined in the thread in accordance with [10.2.5](#) (see [Figure 5](#)).

The other half-nut shall be retempered by holding it for 30 minutes at a part temperature of 10 °C less than the minimum tempering temperature specified in [Table 3](#) or [4](#). After retempering and back to the ambient temperature, the Vickers hardness shall be determined in the thread in accordance with [10.2.5](#) (see [Figure 5](#)).

10.4.3 Test results and requirements

The average of the three hardness readings taken before and after retempering shall be compared. The reduction of hardness after retempering, if any, shall be less than 20 HV.

10.5 Surface discontinuity inspection

The surface discontinuity inspection shall be performed in accordance with ISO 6157-2.

11 Marking and labelling

11.1 General requirements

Marking of nuts shall be included during the manufacturing process. They shall be marked preferably on the top of the nut (i.e. at the opposite side of the bearing face) by indenting or embossing. The height of embossed marking shall not be included in the nut height dimension.

Nuts may also be marked:

- on the flange for flanged nuts,
- on the side by indenting,
- on the chamfer, and in this case embossed marking shall not protrude beyond the bearing surface of the nut,
- on one bearing face by indenting, and in this case it shall not impair functional properties.

Marking of the nuts consists of:

- the property class symbol, as specified in [11.2](#) or [11.3](#),

and

- the manufacturer's identification mark, as specified in [11.4](#).

Nuts manufactured in accordance with the requirements of this document shall be designated in accordance with the designation system specified in [Clause 5](#) and shall be marked in accordance with this [Clause 11](#).

The designation system specified in [Clause 5](#) shall only be used and marking shall only be affixed in accordance with this [Clause 11](#) when all applicable requirements of this document:

- material, heat treatment, chemical composition and steel microstructure as specified in [Clause 7](#),

and

- mechanical and physical properties as specified in [Clause 8](#),

are met, when tested in accordance with [Clause 10](#).

For hot dip galvanized nuts with thread tolerance classes 6AX and 6AZ in accordance with ISO 965-5, additional marking is specified in ISO 10684.

11.2 Property class marking symbols for nuts with full loadability

The property class marking symbols shall be as specified in the second row of [Table 14](#) for nuts with full loadability:

- regular hexagon nuts (style 1) and high hexagon nuts (style 2), and

- other standardized or non-standardized nuts in accordance with this document (nuts with flange, prevailing torque nuts, nuts per drawing, etc.) and with design thread height $m_{th,design,min} \geq 0,73D$ (see [Table 1](#)).

In case where the shape of the nut does not allow that marking, the alternative clock-face marking symbols specified in the third row of [Table 14](#) shall be used.

Table 14 — Property class marking symbols for nuts with full loadability (e.g. regular and high nuts)

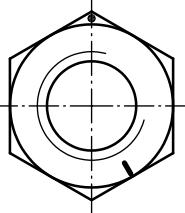
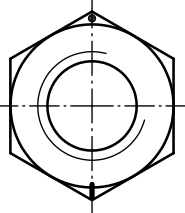
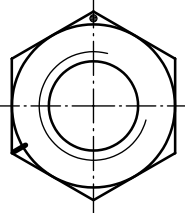
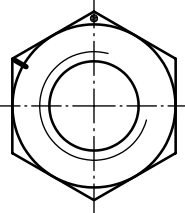
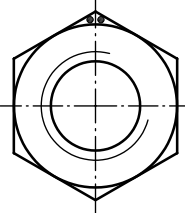
Property class	5	6	8	10	12
Marking symbol	5	6	8	10	12
Alternative clock face marking symbol ^a					

^a The reference twelve o'clock position shall be marked either by the identification mark of the manufacturer or by a dot.

11.3 Property class marking symbols for nuts with reduced loadability

The property class marking symbols (including the preceding digit “0”) shall be as specified in [Table 15](#) for nuts with reduced loadability:

- thin nuts (style 0), and
- other standardized or non-standardized nuts in accordance with this document and with design thread height $0,40D \leq m_{th,design,min} < 0,73D$ (see [Table 1](#)).

Table 15 — Property class marking symbols for nuts with reduced loadability (e.g. thin nuts)

Property class	04	05
Marking symbol	04	05

The alternative clock-face marking of [Table 14](#) is specified for full loadability only, it shall not be used for nuts with reduced loadability.

11.4 Manufacturer’s identification mark

The manufacturer’s identification mark shall be included during the manufacturing process on all nuts which shall be marked with the property class symbol.

A distributor who distributes nuts that are marked with its own identification mark shall be considered to be the manufacturer.

11.5 Nut marking

All nuts in accordance with this document shall be marked with the property class marking symbol in accordance with either [11.2](#) or [11.3](#), and with the manufacturer’s identification mark in accordance with [11.4](#). Nuts shall be marked preferably on the top of the nut (i.e. at the opposite side of the bearing face). Examples are shown in [Figures 7 to 9](#).

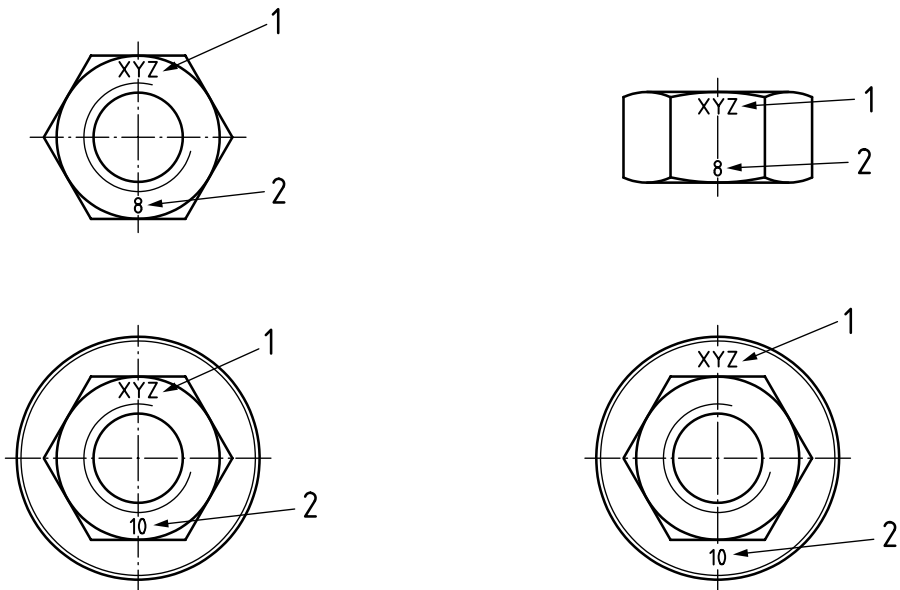

Key

- 1 manufacturer's identification mark
- 2 property class symbol (full loadability)

Figure 7 — Examples of marking for hexagon nuts with full loadability

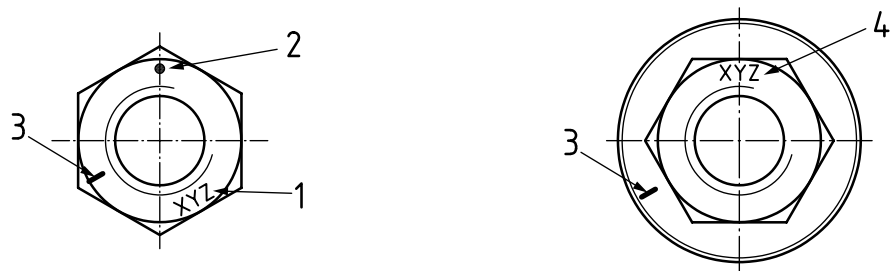

Key

- 1 manufacturer's identification mark
- 2 reference twelve o'clock position marked by a dot
- 3 property class symbol (full loadability)
- 4 reference twelve o'clock position marked by the manufacturer's identification mark (replacing the dot)

Figure 8 — Examples of marking with clock-face system for hexagon nuts with full loadability

For nuts with reduced loadability, the property class symbol specified in [Table 15](#) shall be used (see [Figure 9](#)).

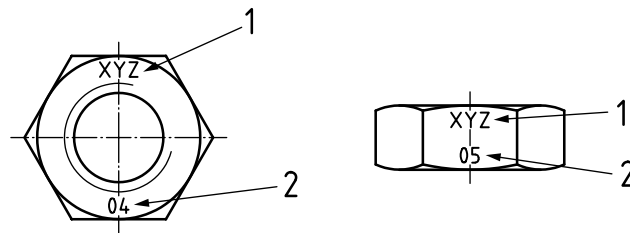

Key

- 1 manufacturer's identification mark
- 2 property class symbol (reduced loadability)

Figure 9 — Examples of marking for hexagon nuts with reduced loadability

Nuts with left-hand thread in accordance with this document shall additionally be marked with a left pointing arrow, see [Figure 10](#). It shall be located at the same face as the property class marking and preferably on the top of the nut.

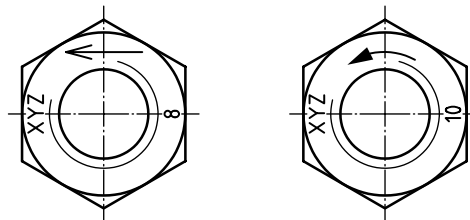
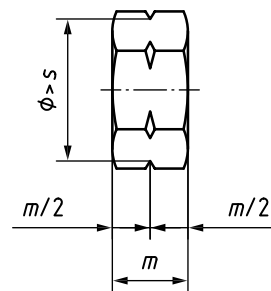

Figure 10 — Examples of marking for left-hand thread

Alternative groove marking for left-hand thread as specified in [Figure 11](#) may also be used for hexagon nuts.



- s width across flats
- m nut height

Figure 11 — Alternative groove marking for left-hand thread

11.6 Marking of the packages (labelling)

All packages for all types of nuts of all sizes and for all property classes in accordance with this document shall be marked through labelling. The labelling shall include at least:

- the manufacturer's and/or distributor's identification and/or name, and
- the property class symbol in accordance with [11.2](#) for nuts with full loadability, or the property class symbol in accordance with [11.3](#) for nuts with reduced loadability, and

— the manufacturing lot number, as specified in ISO 1891-4.

For hot dip galvanized nuts with thread tolerance classes 6AX and 6AZ, additional information is needed for labelling and designation, as specified in ISO 10684.

Annex A (normative)

Thread dimensions of the test mandrel

**Table A.1 — Thread dimensions of the proof load test mandrel —
 Coarse pitch thread**

Dimensions in millimetres

Nut thread <i>D</i>	External thread diameter of the mandrel (lowest quarter of tolerance 6g)		Pitch diameter of the mandrel (tolerance 5h)	
	max.	min.	max.	min.
M5	4,864	4,826	4,480	4,405
M6	5,839	5,794	5,350	5,260
M7	6,839	6,794	6,350	6,260
M8	7,813	7,760	7,188	7,093
M10	9,791	9,732	9,026	8,920
M12	11,767	11,701	10,863	10,745
M14	13,752	13,682	12,701	12,576
M16	15,752	15,682	14,701	14,576
M18	17,707	17,623	16,376	16,244
M20	19,707	19,623	18,376	18,244
M22	21,707	21,623	20,376	20,244
M24	23,671	23,577	22,051	21,891
M27	26,671	26,577	25,051	24,891
M30	29,628	29,522	27,727	27,557
M33	32,628	32,522	30,727	30,557
M36	35,584	35,465	33,402	33,222
M39	38,584	38,465	36,402	36,222

**Table A.2 — Thread dimensions of the proof load test mandrel —
 Fine pitch thread**

Dimensions in millimetres

Nut thread <i>D</i> × <i>P</i>	External thread diameter of the mandrel (lowest quarter of tolerance 6g)		Pitch diameter of the mandrel (tolerance class 5h)	
	max.	min.	max.	min.
M8×1	7,839	7,794	7,350	7,260
M10×1,25	9,813	9,760	9,188	9,093
M10×1	9,839	9,794	9,350	9,260
M12×1,5	11,791	11,732	11,026	10,914
M12×1,25	11,813	11,760	11,188	11,082
M14×1,5	13,791	13,732	13,026	12,911
M16×1,5	15,791	15,732	15,026	14,914
M18×2	17,752	17,682	16,701	16,569
M18×1,5	17,791	17,732	17,026	16,914
M20×2	19,752	19,682	18,701	18,569
M20×1,5	19,791	19,732	19,026	18,914
M22×2	21,752	21,682	20,701	20,569
M22×1,5	21,791	21,732	21,026	20,914
M24×2	23,752	23,682	22,701	22,569
M27×2	26,752	26,682	25,701	25,569
M30×2	29,752	29,682	28,701	28,569
M33×2	32,752	32,682	31,701	31,569
M36×3	35,671	35,577	34,051	33,891
M39×3	38,671	38,577	37,051	36,891

Annex B (informative)

Design principles for nuts

B.1 Basic design principles for nuts

The design of the nuts specified in this document was basically made for hexagon regular nuts (style 1) and for hexagon high nuts (style 2) of product grades A and B, see [Table B.1](#). For detailed technical information on the design principle for nuts, see ISO/TR 16224.

A bolted joint basically consists of two or more work pieces, which are clamped together using an externally threaded fastener (bolt, screw or stud) on one side and an internally threaded part or a nut on the other side (for fully threaded studs, an additional nut is used instead of the head of the bolt or screw).

An externally threaded fastener with specified property class in accordance with ISO 898-1 assembled with a regular or high nut of the mating property class in accordance with [Table 2](#) of this document, is designed to be used up to the yield strength of the externally threaded fastener.

Under tensile load, the failure mode of bolt and nut assemblies corresponds to the lowest value of the following three loads:

- a) thread stripping load of the nut;
- b) ultimate tensile load of the bolt, screw or stud;
- c) thread stripping load of the bolt, screw or stud.

The bolt breaking in the free threaded length after elongation is the intended failure mode of bolt and nut assemblies in case of overloading.

These three loads mainly depend on:

- the hardness, height and effective thread height, diameter, pitch and thread tolerance class of the nut,
- the hardness, diameter, pitch and thread tolerance class of the externally threaded fastener,
- the effective length of engaged thread between the externally threaded fastener and the nut.

These three loads are linked to each other; their interdependence was the analytical basis for the calculation of the different stripping loads by Alexander^[21], and extensive experimental tests proved the Alexander's theory through practical results. In addition, recent FEM-based calculations^[20] also confirmed Alexander's theory.

According to Alexander's theory, hexagon nuts were classified to style 1 (regular nuts) and style 2 (high nuts) in relation to their height, see [Table B.1](#).

Thin nuts (style 0) have a reduced loadability compared to regular nuts or high nuts and are not designed to prevent thread stripping failure mode in case of overloading.

WARNING — Nuts on the market showing vertical bars on each side of the property class symbol (e.g. |8|) do not fulfil the requirements of this document.

NOTE The vertical bars in the warning above are from former DIN 267-4, which was withdrawn in 1994.

**Table B.1 — Minimum height of standard hexagon nuts
(without flange and without prevailing torque feature)**

Dimensions in millimeters

Thread D	Width across flats s_{nom}	Minimum height of hexagon nuts			
		Regular nuts (style 1) $0,80D \leq m_{\text{min}} < 0,89D$		High nuts (style 2) $m_{\text{min}} \geq 0,89D$	
		m_{min}	m_{min}/D	m_{min}	m_{min}/D
5	8	4,40	0,88	4,80	0,96
6	10	4,90	0,82	5,40	0,90
7	11	6,14	0,88	6,84	0,98
8	13	6,44	0,81	7,14	0,90
10	16	8,04	0,80	8,94	0,89
12	18	10,37	0,86	11,57	0,96
14	21	12,10	0,86	13,40	0,96
16	24	14,10	0,88	15,70	0,98
18	27	15,10	0,84	16,90	0,94
20	30	16,90	0,85	19,00	0,95
22	34	18,10	0,82	20,50	0,93
24	36	20,20	0,84	22,60	0,94
27	41	22,50	0,83	25,40	0,94
30	46	24,30	0,81	27,30	0,91
33	50	27,40	0,83	30,90	0,94
36	55	29,40	0,82	33,10	0,92
39	60	31,80	0,82	35,90	0,92

B.2 Nuts with diameters $D < 5$ mm and $D > 39$ mm

Mechanical properties for bolts and nuts have been specified using the Alexander theory^[21] for fasteners with nominal diameters 5 mm to 39 mm only, on the basis of hexagon nut dimensions specified in ISO 4032 (regular nuts, style 1) and ISO 4033 (high nuts, style 2) with the specified width across flats and minimum heights shown in [Table B.1](#).

Nuts with $D < 5$ mm and nuts with $D > 39$ mm given in ISO 4032 have a minimum height m_{min} less than $0,80D$. These nuts heights originate from former DIN 934¹⁾, and they have not been resized up to now: **this means that such nuts would need a higher hardness and/or a greater minimum height to match the Alexander theory and meet the requirements of this document.** However, increased hardness alone cannot always compensate for an insufficient height to avoid the thread stripping failure mode of the nut.

Therefore, mechanical properties for nuts with $D < 5$ mm and for nuts with $D > 39$ mm are not specified in this document, and property classes cannot be assigned in product standards. Consequently, the mechanical properties and related tests to be performed as well as the relevant marking and labelling should be specified by agreement between the purchaser and the supplier.

1) DIN 934 has been withdrawn in 1992 and replaced by ISO 4032.

Annex C (informative)

Stress under proof load, S_p

Stress under proof load S_p is related to proof load values F_p and to the nominal stress area of the bolt A_s , as given in [Formula \(C.1\)](#):

$$S_p = \frac{F_p}{A_{s,nom}} \quad (C.1)$$

Stress under proof load is given in [Tables C.1](#) and [C.2](#) for information only.

S_p values of [Tables C.1](#) and [C.2](#) are the result of the calculations provided in ISO/TR 16224. These calculation groupings are the basis for the revision of the hardness values and proof load values of this document. During this last revision, the proof load values from ISO 898-2:1992 were updated according to the recalculated values only if the difference between the stress under proof load 1992 and 2022 was above 5 %. There is therefore a non-consistency between the normative proof load values of this document and the corresponding calculated S_p given in [Tables C.1](#) and [C.2](#).

The proof load values specified in [Tables 5](#) and [6](#) of this document are to be met.

Table C.1 — Stress under proof load, S_p — Coarse pitch thread

Thread <i>D</i>	Stress under proof load, S_p (MPa)						
	Property class						
	04	05	5	6	8	10	12
Nominal tensile strength $R_{m,nom}$ of the mating bolt (ISO 898-1)	—	—	500	600	800	1 000	1 200
M5 to M7	380	500	585	680	860	1 040	1 150
M8 to M10			605	705	885		1 180
M12 to M16			610	710	895	1 050	1 195
M18 to M24			640	740	965	1 070	1 205
M27 to M39			660	760	985	1 095	1 220

Table C.2 — Stress under proof load, S_p — Fine pitch thread

Thread <i>D</i> (mm)	Stress under proof load, S_p (MPa)					
	Property class					
	04	05	6	8	10	12
Nominal tensile strength $R_{m,nom}$ of the mating bolt (ISO 898-1)	—	—	600	800	1 000	1 200
8 to 10	380	500	795	970	1 100	1 200
12 to 16			790		1 110	1 210
18 to 24			870	1 030	1 080	1 215
27 to 33			870	1 045		1 230
36 to 39			930	1 090		

Proof load values not specified in [Table 5](#) or [6](#) should be calculated by using the exact data for A_s (see hereafter) and only at the end, the values should be rounded to the next upper 10 N up to 100 000 N, and to the next upper 100 N above.

In accordance with ISO 898-1, the nominal stress area A_s is calculated as given in [Formula \(C.2\)](#) and [Formula \(C.3\)](#):

$$A_{s,\text{nom}} = \frac{\pi}{4} \left(\frac{d_2 + d_3}{2} \right)^2 \quad (\text{C.2})$$

where

d_2 is the basic pitch diameter of external thread in accordance with ISO 724

d_3 is the minor diameter of external thread

$$d_{3,\text{nom}} = d_1 - \frac{H}{6} \quad (\text{C.3})$$

where

d_1 is the basic minor diameter of external thread in accordance with ISO 724

H is the height of the fundamental triangle of the thread in accordance with ISO 68-1

Bibliography

- [1] ISO 68-1, *ISO general purpose screw threads — Basic profile — Part 1: Metric screw threads*
- [2] ISO 261, *ISO general purpose metric screw threads — General plan*
- [3] ISO 262, *ISO general purpose metric screw threads — Selected sizes for screws, bolts and nuts*
- [4] ISO 286-2, *Geometrical product specifications (GPS) — ISO code system for tolerances on linear sizes — Part 2: Tables of standard tolerance classes and limit deviations for holes and shafts*
- [5] ISO 898-1, *Mechanical properties of fasteners made of carbon steel and alloy steel — Part 1: Bolts, screws and studs with specified property classes — Coarse thread and fine pitch thread*
- [6] ISO 898-3, *Mechanical properties of fasteners made of carbon steel and alloy steel — Part 3: Flat washers with specified property classes*
- [7] ISO 898-6,²⁾ *Mechanical properties of fasteners — Part 6: Nuts with specified proof load values — Fine pitch thread*
- [8] ISO 965-1, *ISO general purpose metric screw threads — Tolerances — Part 1: Principles and basic data*
- [9] ISO 965-2, *ISO general purpose metric screw threads — Tolerances — Part 2: Limits of sizes for general purpose external and internal screw threads — Medium quality*
- [10] ISO 965-5, *ISO general purpose metric screw threads — Tolerances — Part 5: Limits of sizes for internal screw threads to mate with hot-dip galvanized external screw threads with maximum size of tolerance position h before galvanizing*
- [11] ISO 4032, *Hexagon regular nuts (style 1) — Product grades A and B*
- [12] ISO 4033, *Hexagon high nuts (style 2) — Product grades A and B*
- [13] ISO 16047, *Fasteners — Torque/clamp force testing*
- [14] ISO/TR 16224, *Technical aspects of nut design*
- [15] ISO 16426, *Fasteners — Quality assurance system*
- [16] ISO 18265, *Metallic materials — Conversion of hardness values*
- [17] EN 10269, *Steels and nickel alloys for fasteners with specified elevated and/or low temperature properties*
- [18] ASTM A194/A194M, *Standard Specification for Carbon Steel, Alloy Steel, and Stainless Steel Nuts for Bolts for High Pressure or High Temperature Service, or Both*
- [19] ASTM A320/A320M, *Standard Specification for Alloy-Steel and Stainless Steel Bolting for Low-Temperature Service*
- [20] HAGIWARA M., HIROAKI S., *Verification of the Design Concept in Bolt/Nut Assemblies for the revision of ISO 898-2 and ISO 898-6*. Journal of Advanced Mechanical Design, Systems, and Manufacturing, vol.1, No. 5, 2007, pp. 755-762
- [21] ALEXANDER E.M. *Analysis and design of threaded assemblies*. 1977 SAE Transactions, Paper No. 770420

2) Withdrawn and replaced by ISO 898-2.

Bureau of Indian Standards

BIS is a statutory institution established under the *Bureau of Indian Standards Act, 2016* to promote harmonious development of the activities of standardization, marking and quality certification of goods and attending to connected matters in the country.

Copyright

BIS has the copyright of all its publications. No part of these publications may be reproduced in any form without the prior permission in writing of BIS. This does not preclude the free use, in the course of implementing the standard, of necessary details, such as symbols and sizes, type or grade designations. Enquiries relating to copyright be addressed to the Head (Publication & Sales), BIS.

Review of Indian Standards

Amendments are issued to standards as the need arises on the basis of comments. Standards are also reviewed periodically; a standard along with amendments is reaffirmed when such review indicates that no changes are needed; if the review indicates that changes are needed, it is taken up for revision. Users of Indian Standards should ascertain that they are in possession of the latest amendments or edition by referring to the website-www.bis.gov.in or www.standardsbis.in.

This Indian Standard has been developed from Doc No.: PGD 37 (22055)

Amendments Issued Since Publication

Amend No.	Date of Issue	Text Affected

BUREAU OF INDIAN STANDARDS

Headquarters:

Manak Bhavan, 9 Bahadur Shah Zafar Marg, New Delhi 110002

Telephones: 2323 0131, 2323 3375, 2323 9402

Website: www.bis.gov.in

Regional Offices:

	Telephones
Central : 601/A, Konnectus Tower -1, 6 th Floor, DMRC Building, Bhavbhuti Marg, New Delhi 110002	{ 2323 7617
Eastern : 8 th Floor, Plot No 7/7 & 7/8, CP Block, Sector V, Salt Lake, Kolkata, West Bengal 700091	{ 2367 0012 2320 9474
Northern : Plot No. 4-A, Sector 27-B, Madhya Marg, Chandigarh 160019	{ 265 9930
Southern : C.I.T. Campus, IV Cross Road, Taramani, Chennai 600113	{ 2254 1442 2254 1216
Western : 5 th Floor/MTNL CETTM, Technology Street, Hiranandani Gardens, Powai, Mumbai 400076	{ 2570 0030 2570 2715

Branches : AHMEDABAD, BENGALURU, BHOPAL, BHUBANESHWAR, CHANDIGARH, CHENNAI, COIMBATORE, DEHRADUN, DELHI, FARIDABAD, GHAZIABAD, GUWAHATI, HARYANA (CHANDIGARH), HUBLI, HYDERABAD, JAIPUR, JAMMU, JAMSHEDPUR, KOCHI, KOLKATA, LUCKNOW, MADURAI, MUMBAI, NAGPUR, NOIDA, PARWANOO, PATNA, PUNE, RAIPUR, RAJKOT, SURAT, VIJAYAWADA.