इस्पात के चूड़ीदार बंधको की तकनीकी
पूर्ति शर्तें

भाग 11 विद्युत निक्षेपित लेपन सिस्टम्स
(पाँचवां पुनरीक्षण)

**Technical Supply Conditions for
Threaded Steel Fasteners**
Part 11 Electroplated Coating Systems
(*Fifth Revision*)

ICS 21.060.01

© BIS 2024
© ISO 2022



भारतीय मानक ब्यूरो
BUREAU OF INDIAN STANDARDS
मानक भवन, 9 बहादुर शाह ज़फर मार्ग, नई दिल्ली - 110002
MANAK BHAVAN, 9 BAHADUR SHAH ZAFAR MARG
NEW DELHI - 110002
www.bis.gov.in www.standardsbis.in

NATIONAL FOREWORD

This Indian Standard (Part 11) (Fifth Revision) which is identical to ISO 4042 : 2022 'Fasteners — Electroplated coating systems' issued by the International Organization for Standardization (ISO) was adopted by the Bureau of Indian Standards on the recommendation of the General Engineering and Fasteners Sectional Committee and after approval of the Production and General Engineering Division Council.

This standard was first published in 1961 and was subsequently revised in 1967, 1996, 2002 and 2020. This fifth revision has been brought out to align it with the latest version of ISO 4042.

The major changes in this revision are as follows:

- a) In clause [1](#), a statement has been added that the requirements of this standard for electroplated fasteners have precedence over other standards dealing with electroplating;
- b) In clause [4.4](#), the measures to prevent internal hydrogen embrittlement for nuts, flat washers and case-hardened screws have been completely revised; and
- c) In clause [6.4](#), the reference areas for thickness determination have been more clearly specified.

This standard is published in 18 parts. Other parts in this series are:

- | | |
|---------|---|
| Part 1 | General requirements for bolts, screws, studs and nuts |
| Part 2 | Tolerances for fasteners — Bolts, screws, studs and nuts — Product grades A, B and C |
| Part 3 | Mechanical properties of fasteners made of carbon steel and bolts screws and studs |
| Part 5 | Mechanical properties of fasteners made of carbon steel and alloy steel — Set screws and similar threaded fasteners with specified hardness classes — Coarse thread and fine pitch thread |
| Part 6 | Mechanical properties of fasteners made of carbon steel and alloy steel — Nuts with specified property classes — Coarse thread and fine pitch thread |
| Part 7 | Mechanical properties and test methods for nuts without specified proof loads |
| Part 8 | Prevailing torque type steel nuts — Functional properties |
| Part 9 | Surface discontinuities |
| Part 10 | Surface discontinuities — Nuts Phosphate |
| Part 12 | coatings on threaded fasteners |
| Part 13 | Hot dip galvanized coatings on threaded fasteners |
| Part 14 | Mechanical properties of corrosion-resistant stainless-steel fasteners |
| Part 16 | Designation system for fasteners |
| Part 17 | Inspections sampling and acceptance procedure |
| Part 18 | Packaging |
| Part 19 | Axial load fatigue testing of bolts screws and studs |
| Part 20 | Torsional test and minimum torques for bolts and screws with nominal diameters 1 mm to 10 mm |

The text of ISO standard has been approved as suitable for publication as an Indian Standard without deviations. Certain conventions are, however, not identical to those used in Indian Standards. Attention is particularly drawn to the following:

- a) Wherever the words 'International Standard' appear referring to this standard, they should be read as 'Indian Standard'.; and
- b) Comma (,) has been used as a decimal marker while in Indian Standards, the current practice is to use a point (.) as the decimal marker.

In this adopted standard, reference appears to certain International Standards for which Indian Standards also exist. The corresponding Indian Standards, which are to be substituted in their respective places, are listed below along with their degree of equivalence for the editions indicated:

<i>International Standard</i>	<i>Corresponding Indian Standard</i>	<i>Degree of Equivalence</i>
ISO 1502 : 1996 ISO general-purpose metric screw threads — Gauges and gauging	IS 2334 : 2001/ISO 1502 : 1996 ISO general purpose metric screw threads — Gauges and gauging (<i>second revision</i>)	Identical
ISO 2177 : 2003 Metallic coatings — Measurement of coating thickness — Coulometric method by anodic dissolution	IS 14126 : 2019/ISO 2177 : 2003 Metallic coatings — Measurement of coating thickness — Coulometric method by anodic dissolution (<i>first revision</i>)	Identical
ISO 8991 : 1986 Designation system for fasteners	IS 1367 (Part 16) : 2002/ISO 8991 : 1986 Technical supply conditions for threaded steel fasteners: Part 16 Designation system for fasteners (<i>third revision</i>)	Identical
ISO 9227 : 2017 Corrosion tests in artificial atmospheres — Salt spray tests	IS 5528 : 2024/ISO 9227 : 2022 Corrosion tests in artificial atmospheres — Salt spray tests (<i>second revision</i>)	Identical
ISO 15330 Fasteners — Preloading test for the detection of hydrogen embrittlement — Parallel bearing surface method	IS 17445 : 2020/ISO 15330 : 1999 Fasteners — Preloading test for the detection of hydrogen embrittlement — Parallel bearing surface method	Identical

The Committee has reviewed the provisions of the following International Standards referred in this adopted standard and has decided that they are acceptable for use in conjunction with this standard:

<i>International Standard</i>	<i>Title</i>
ISO 1456 : 2009	Metallic and other inorganic coatings — Electrodeposited coatings of nickel, nickel plus chromium, copper plus nickel and of copper plus nickel plus chromium
ISO 1463	Metallic and oxide coatings — Measurement of coating thickness — Microscopical method
ISO 1891-2 : 2014	Fasteners — Terminology — Part 2: Vocabulary and definitions for coatings

<i>International Standard</i>	<i>Title</i>
ISO 2082	Metallic and other inorganic coatings — Electroplated coatings of cadmium with supplementary treatments on iron or steel
ISO 2093	Electroplated coatings of tin — Specification and test methods
ISO 2178	Non-magnetic coatings on magnetic substrates — Measurement of coating thickness — Magnetic method
ISO 3497	Metallic coatings — Measurement of coating thickness — X-ray spectrometric method
ISO 3613	Metallic and other inorganic coatings — Chromate conversion coatings on zinc, cadmium, aluminium-zinc alloys and zinc-aluminium alloys — Test methods
ISO 4521	Metallic and other inorganic coatings — Electrodeposited silver and silver alloy coatings for engineering purposes — Specification and test methods
ISO 15726	Metallic and other inorganic coatings — Electrodeposited zinc alloys with nickel, cobalt or iron
ISO 16047	Fasteners — Torque/clamp force testing
ISO 16228	Fasteners — Types of inspection documents
ISO 21968	Non-magnetic metallic coatings on metallic and non-metallic basis materials — Measurement of coating thickness — Phase-sensitive eddy-current method
ASME B18.6.3	Machine screws, tapping screws, and metallic drive screws (Inch series)

Contents

Page

Introduction	ix
1 Scope	1
2 Normative references	1
3 Terms and definitions	2
4 General characteristics of the coating	2
4.1 Coating metals or alloys and main purposes	2
4.2 Build-up of basic electroplated coating systems.....	3
4.3 Coating systems and coating processes.....	4
4.4 Internal hydrogen embrittlement	4
4.4.1 General	4
4.4.2 Fasteners with hardness up to 360 HV	5
4.4.3 Fasteners with hardness above 360 HV and up to 390 HV	5
4.4.4 Fasteners with hardness above 390 HV	5
4.4.5 Fasteners in accordance with ISO 898-1, ISO 898-2 and ISO 898-3.....	6
4.4.6 Case-hardened fasteners.....	7
4.4.7 Work hardened fasteners and fasteners with threads rolled after heat treatment.....	8
4.4.8 Fasteners with bainitic structure	9
4.5 Baking.....	9
5 Corrosion protection and testing	9
5.1 General.....	9
5.2 Neutral salt spray test (NSS) for zinc-based coating systems.....	10
5.3 Sulfur dioxide test (Kesternich test).....	11
5.4 Bulk handling, automatic processes such as feeding and/or sorting, storage and transport.....	12
6 Dimensional requirements and testing	12
6.1 General.....	12
6.2 Fasteners with ISO metric thread	12
6.2.1 Coating thickness.....	12
6.2.2 Gaugeability and assemblability	13
6.3 Other fasteners.....	13
6.4 Test methods for thickness determination	14
7 Mechanical and physical properties and testing	16
7.1 General.....	16
7.2 Appearance.....	16
7.3 Corrosion resistance related to temperature	16
7.4 Torque/clamp force relationship.....	16
7.5 Determination of hexavalent chromium	16
8 Applicability of tests	17
8.1 General.....	17
8.2 Tests mandatory for each lot	17
8.3 Tests for in-process control.....	17
8.4 Tests to be performed when specified by the purchaser.....	17
9 Designation system	17
9.1 General.....	17
9.2 Designation of electroplated coating systems for the order	18
9.3 Examples of designation of hexavalent chromium free electroplated coating systems for fasteners.....	20
9.4 Designation of fasteners with electroplated coating systems for labelling.....	21

10	Ordering requirements for electroplating	21
11	Storage conditions	22
Annex A (informative)	Design and assembly aspects for joints with coated fasteners	23
Annex B (informative)	Hydrogen embrittlement consideration	31
Annex C (informative)	Corrosion protection related to zinc coatings with chromate conversion coatings	36
Annex D (informative)	Coating thickness and thread clearance for ISO metric threads	37
Annex E (informative)	Coating systems tested in accordance with ISO 9227, NSS — Evaluation of cabinet corrosivity for the neutral salt spray test	44
Annex F (informative)	Obsolete designation codes for electroplated coating systems on fasteners according to ISO 4042:1999	54
	Bibliography	57

Introduction

ISO 4042:1999 was completely revised to take into account new developments related to hexavalent chromium free passivations, application of sealants and top coats, requirements for functional properties as well as results of research work to minimize the risk of hydrogen embrittlement. This revision was published in 2018.

The last editions of ISO 2081:2018 as well as ISO 19598:2016, which are general standards for electroplating, are not adequate to cover the requirements for electroplated fasteners dealt with in ISO 4042, especially with regard to hydrogen embrittlement and baking. Therefore, a new revision of ISO 4042:2018 was necessary to delete all references to these two general standards to avoid any contradictions.

For electroplated nuts, flat washers, and case-hardened screws, measures to mitigate the risk of hydrogen embrittlement, especially in relation to baking, have been revised to be consistent with revisions of ISO 898-2 and ISO 2702, and to reflect findings from the latest research works. For electroplated flat washers in accordance with ISO 898-3, it is generally accepted that tensile stress resulting from intended and unintended bending in service may increase the risk of hydrogen embrittlement. An appropriate test method to simulate such a scenario is currently under investigation.

Indian Standard
**TECHNICAL SUPPLY CONDITIONS FOR THREADED STEEL
FASTENERS**
PART 11 ELECTROPLATED COATING SYSTEMS

(*Fifth Revision*)

1 Scope

This document specifies requirements for steel fasteners with electroplated coatings and coating systems. The requirements related to dimensional properties also apply to fasteners made of copper or copper alloys.

It also specifies requirements and gives recommendations to minimize the risk of hydrogen embrittlement, see [4.4](#) and [Annex B](#).

It mainly applies to fasteners with zinc and zinc alloy coating systems (zinc, zinc-nickel, zinc-iron) and cadmium, primarily intended for corrosion protection and other functional properties:

- with or without conversion coating,
- with or without sealant,
- with or without top coat,
- with or without lubricant (integral lubricant and/or subsequently added lubricant).

Specifications for other electroplated coatings and coating systems (tin, tin-zinc, copper-tin, copper-silver, copper, silver, copper-zinc, nickel, nickel-chromium, copper-nickel, copper-nickel-chromium) are included in this document only for dimensional requirements related to fasteners with ISO metric threads.

The requirements of this document for electroplated fasteners take precedence over other documents dealing with electroplating.

This document applies to steel bolts, screws, studs and nuts with ISO metric thread, to other threaded fasteners and to non-threaded fasteners such as washers, pins, clips and rivets.

NOTE Electroplating is also applied to stainless steel fasteners, e.g. for the purpose of lubrication in order to avoid galling.

Information for design and assembly of coated fasteners is given in [Annex A](#).

This document does not specify requirements for properties such as weldability or paintability.

2 Normative references

The following documents are referred to in the text in such a way that some or all of their content constitutes requirements of this document. For dated references, only the edition cited applies. For undated references, the latest edition of the referenced document (including any amendments) applies.

ISO 1456, *Metallic and other inorganic coatings — Electrodeposited coatings of nickel, nickel plus chromium, copper plus nickel and of copper plus nickel plus chromium*

ISO 1463, *Metallic and oxide coatings — Measurement of coating thickness — Microscopical method*

ISO 1502, *ISO general-purpose metric screw threads — Gauges and gauging*

ISO 1891-2, *Fasteners — Terminology — Part 2: Vocabulary and definitions for coatings*

ISO 2082, *Metallic and other inorganic coatings — Electroplated coatings of cadmium with supplementary treatments on iron or steel*

ISO 2093, *Electroplated coatings of tin — Specification and test methods*

ISO 2177, *Metallic coatings — Measurement of coating thickness — Coulometric method by anodic dissolution*

ISO 2178, *Non-magnetic coatings on magnetic substrates — Measurement of coating thickness — Magnetic method*

ISO 3497, *Metallic coatings — Measurement of coating thickness — X-ray spectrometric methods*

ISO 3613, *Metallic and other inorganic coatings — Chromate conversion coatings on zinc, cadmium, aluminium-zinc alloys and zinc-aluminium alloys — Test methods*

ISO 4521, *Metallic and other inorganic coatings — Electrodeposited silver and silver alloy coatings for engineering purposes — Specification and test methods*

ISO 8991, *Designation system for fasteners*

ISO 9227, *Corrosion tests in artificial atmospheres — Salt spray tests*

ISO 15330, *Fasteners — Preloading test for the detection of hydrogen embrittlement — Parallel bearing surface method*

ISO 15726, *Metallic and other inorganic coatings — Electrodeposited zinc alloys with nickel, cobalt or iron*

ISO 16047, *Fasteners — Torque/clamp force testing*

ISO 16228, *Fasteners — Types of inspection documents*

ISO 21968, *Non-magnetic metallic coatings on metallic and non-metallic basis materials — Measurement of coating thickness — Phase-sensitive eddy-current method*

ASME B18.6.3, *Machine Screws, Tapping Screws, and Metallic Drive Screws (Inch Series)*

3 Terms and definitions

For the purposes of this document, the terms and definitions given in ISO 1891-2 and the following apply.

ISO and IEC maintain terminology databases for use in standardization at the following addresses:

- ISO Online browsing platform: available at <https://www.iso.org/obp>
- IEC Electropedia: available at <https://www.electropedia.org/>

3.1 reference panel

reference material that is to be exposed to check the corrosivity level of the test cabinet used for fastener testing

4 General characteristics of the coating

4.1 Coating metals or alloys and main purposes

Electroplated coating systems for steel fasteners are primarily applied for corrosion protection and functional properties, such as torque/clamp force relationship.

In addition, other functional properties or decorative properties can be specified; see [Annex A](#).

Commonly used electroplated coatings for fasteners are given in [Table 1](#) along with their main purpose(s). Additional information, such as designation or decorative aspects, can be found in other relevant ISO standards listed in the last column of [Table 1](#).

Table 1 — Electroplated coatings in accordance with their main purpose(s) and related ISO standards

Coating metal(s)		Nature	Main purpose of the coating for fasteners	ISO standard
Symbol	Element			
Zn	Zinc	Metal	P/D/F	—
ZnNi	Zinc-nickel	Alloy	P/D/F	ISO 15726
ZnFe	Zinc-iron	Alloy	P/D/F	ISO 15726
Cd	Cadmium ^a	Metal	P/F	ISO 2082
Ni	Nickel	Metal	D/F	ISO 1456
Ni+Cr	Nickel+chromium	Multi-layer	D	ISO 1456
Cu+Ni	Copper+nickel	Multi-layer	D	ISO 1456
Cu+Ni+Cr	Copper+nickel+chromium	Multi-layer	D	ISO 1456
CuZn	Brass	Alloy	D	—
CuSn	Copper-tin (bronze)	Alloy	F	—
Cu	Copper	Metal	F/D	—
Ag	Silver	Metal	F/D	ISO 4521
CuAg	Copper-silver	Alloy	F	—
Sn	Tin	Metal	F	ISO 2093
SnZn	Tin-zinc	Alloy	F/P	—

P corrosion protection
 F functional properties
 D decorative properties (colour, aspect)
^a Cadmium is restricted or prohibited for many applications (remaining cadmium users are predominantly military and aerospace industries).

4.2 Build-up of basic electroplated coating systems

[Figure 1](#) shows basic electroplated coating systems.

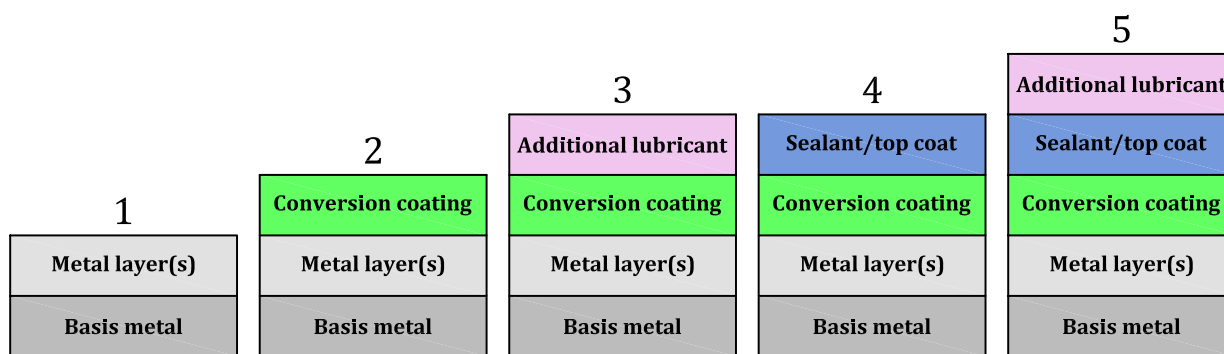

Key

- 1 only metal layer(s)
- 2 metal layer(s) + conversion coating
- 3 metal layer(s) + conversion coating + additional lubricant
- 4 metal layer(s) + conversion coating + sealant/top coat
- 5 metal layer(s) + conversion coating + sealant/top coat + additional lubricant

Figure 1 — Basic electroplated coating systems (schematic)

A conversion coating increases corrosion protection on zinc, zinc alloy and cadmium coatings. It may be a passivation (chromium VI free) or a chromatisation (chromium VI containing). The conversion coating can also provide better adhesion for additional layer(s) and/or additional colour/paint.

An additional sealant/top coat (with or without integral lubricant) may be chosen to increase corrosion resistance and/or to achieve other specific properties (e.g. torque/clamp force properties, resistance to chemicals, mechanical resistance, aspect, colour, thermal stability, increased electrical resistance, UV radiation resistance). The selection of the nature of a sealant or top coat should be based on the desired additional properties.

An additional lubricant may be applied to adjust or amend the torque/clamp force relationship.

NOTE Electroplating is also applied on stainless steel fasteners, e.g. for the purpose of lubrication in order to avoid galling.

4.3 Coating systems and coating processes

The type and geometry of the fastener should be considered when selecting a coating system and the related coating process (see [Annex A](#)) as well as hydrogen embrittlement considerations (see [Annex B](#)).

The electroplating process shall be under control, in accordance with a recognized standard and/or a specification by agreement with the purchaser. Recommendations for supplemental process verification with regard to internal hydrogen embrittlement are given in [4.5](#) and [B.4](#).

4.4 Internal hydrogen embrittlement

4.4.1 General

The three following conditions shall be **concurrently** present for fasteners to generate a risk of Internal Hydrogen Embrittlement (IHE), see also [Annex B](#):

- high tensile strength or high hardness, including case-hardening;
- tensile stress, including residual tensile stress;
- atomic hydrogen absorbed by the steel.

The susceptibility to IHE increases with increasing hardness of the fastener. Appropriate measures for prevention of IHE for quenched and tempered fasteners depending on hardness are specified in [Table 2](#).

[Table 2](#) and [4.4.2](#) to [4.4.4](#) provide the general guidelines for measures related to IHE as a function of hardness.

The general guidelines of [Table 2](#) are translated in [4.4.5](#) and [4.4.6](#) into normative requirements applicable specifically to each type of fasteners in relation to its property class (see [Tables 3](#) to [5](#)) or its core hardness (see [Tables 6](#) and [7](#)). These specific normative requirements are based on both hardness and the degree of tensile stress experienced by each type of fasteners by its design and function.

Table 2 — Measures related to IHE for quenched and tempered fasteners with regard to hardness^a

	360 HV	390 HV
A	B	C
No supplemental process verification or product testing with regard to IHE AND No baking necessary	Supplemental process verification and/or product testing with regard to IHE OR Baking	Supplemental process verification and/or product testing with regard to IHE AND Baking (baking temperature and duration shall be specified)
—	At the discretion of the fastener manufacturer	—
See 4.4.2	See 4.4.3 and B.6	See 4.4.4 and B.6

^a For fasteners work hardened to high hardness, see [4.4.7](#) and [B.5](#).

4.4.2 Fasteners with hardness up to 360 HV

When electroplating quenched and tempered fasteners with specified maximum hardness up to 360 HV (**A** in [Tables 2](#), [3](#), [4](#) and [5](#)), no supplemental process verification with regard to IHE and no baking are necessary.

4.4.3 Fasteners with hardness above 360 HV and up to 390 HV

When electroplating quenched and tempered fasteners with specified maximum hardness above 360 HV and up to and including 390 HV (**B** in [Tables 2](#), [3](#) and [5](#)), at the choice of the fastener manufacturer baking is not required provided supplemental process verification and/or product testing with regard to IHE have been performed.

For fasteners in this specified hardness range, electroplating does not pose a risk of IHE. In case of a failure in a product test, it cannot be assumed that baking the parts would have prevented such failure: the metallurgical and physical conditions of the fastener material should be investigated for non-conformances. For more information, see [B.2](#) and [B.4](#).

4.4.4 Fasteners with hardness above 390 HV

When electroplating quenched and tempered fasteners with specified maximum hardness above 390 HV (**C** in [Tables 2](#) and [3](#)), baking is required; see [B.4](#) for minimum recommended baking temperature and duration.

The following exemptions apply:

- for fasteners which are not specified to be under tensile stress by design or standard (e.g. set screws in accordance with ISO 898-5), baking is not required (see [B.2](#));

- induction hardened ends (e.g. for thread forming screws) shall not be considered for determining measures related to IHE in relation to [Table 2](#), because they are normally not subjected to tensile stress provided that the end protrudes through the mating thread;
- alkaline zinc-nickel electroplatings with nickel content of 12 % to 16 % present a lower risk of IHE (see [B.3](#)), therefore it is possible to avoid baking; the decision to not carry out baking shall be based on testing (see [B.6](#)) and be agreed between the supplier and the purchaser.

NOTE 1 Alkaline zinc-nickel electroplating processes with typical nickel content of 12 % to 16 % are also known as “low hydrogen embrittlement” processes (LHE) in the aerospace industry, see [B.3](#).

NOTE 2 For acid zinc-nickel electroplatings, studies have shown similar benefits as for alkaline zinc-nickel electroplatings, however more data are necessary to confirm baking avoidance.

4.4.5 Fasteners in accordance with ISO 898-1, ISO 898-2 and ISO 898-3

For fasteners in accordance with ISO 898-1, ISO 898-2 and ISO 898-3, Tables 3, 4 and 5 apply.

Table 3 — Measures related to IHE for fasteners in accordance with ISO 898-1

Property class	< 10.9	10.9	12.9/12.9
Measures related to IHE	A	B	C
	No supplemental process verification or product testing with regard to IHE AND No baking necessary	Supplemental process verification and/or product testing with regard to IHE OR Baking	Supplemental process verification and/or product testing with regard to IHE AND Baking ^{a, b}
	—	At the choice of the fastener manufacturer	—
	See 4.4.2	See 4.4.3 and B.6	See 4.4.4 and B.6
^a For alkaline zinc-nickel electroplatings with nickel content of 12 % to 16 %, the decision to not carry out baking shall be based on testing (see B.6) and be agreed between the supplier and the purchaser. ^b For baking temperature and duration, see B.4 .			

Table 4 — Measures related to IHE for nuts in accordance with ISO 898-2

Property class	≤ 12
Measures related to IHE	A
	No supplemental process verification or product testing with regard to IHE AND No baking necessary ^{a, b}
	See 4.4.2
^a Investigations have shown that tensile stress in critical areas of nuts (including nuts with flange) is always lower than tensile stress in the thread of the mating bolts, screws or studs with corresponding property class (see measures related to IHE in Table 3); nuts in accordance with ISO 898-2 (all property classes) always have a hardness less than 390 HV, therefore baking is not necessary. ^b For all-metal prevailing torque nuts of property classes 10 and 12, supplemental process verification or baking is required, at the choice of the manufacturer.	

Table 5 — Measures related to IHE for flat washers in accordance with ISO 898-3

Property class	≤ 300HV	380HV
Measures related to IHE	A	B
	No supplemental process verification or product testing with regard to IHE AND No baking necessary ^a	Supplemental process verification and/or product testing with regard to IHE OR Baking ^b
	—	At the choice of the fastener manufacturer
	See 4.4.2	See 4.4.3
^a When flat washers of property class 300HV are to be used in special applications (e.g. enlarged or slotted holes) where bending stress may be present, baking may be necessary and shall be required by the purchaser at the time of the order. For baking temperature and duration, see B.4 . ^b When flat washers of property class 380HV are to be used in special applications (e.g. enlarged or slotted holes) where bending stress may be present, baking is necessary and shall be required by the purchaser at the time of the order. For baking temperature and duration, see B.4 .		

4.4.6 Case-hardened fasteners

Fasteners where the surface is intentionally case-hardened to fulfil specific function(s) include:

- tapping screws (see ISO 2702),
- thread-forming screws for metallic materials,
- self-drilling screws (see e.g. ISO 10666),
- screws for soft materials (e.g. plastic, wood).

Measures related to IHE for case-hardened screws are based on core hardness, which has the most significant effect on IHE susceptibility (see [B.3](#)).

Case-hardened screws are grouped into two different categories, a) and b).

a) Case hardened screws not designed for high clamp force

This category includes tapping screws and self-drilling screws with thread according to ISO 1478, screws for soft materials, etc.

As these screws are typically not designed for high clamp force, the risk of IHE is significantly reduced.

Measures related to IHE for this category are specified in [Table 6](#).

NOTE Non-threaded case-hardened fasteners not subjected to tensile stress by design (such as pins or washers) do not need special measures related to IHE, unless specifically agreed between the purchaser and the manufacturer for a particular application.

b) Case hardened and tempered screws intended to be preloaded

This category includes case-hardened and tempered screws that form ISO metric mating threads according to ISO 965-1 and other case-hardened and tempered thread-forming or self-drilling screws intended to be preloaded.

Measures related to IHE for this category are specified in [Table 7](#).

Table 6 — Measures related to IHE for case-hardened screws typically not designed for high clamp force

Core hardness	≤ 360 HV	> 360 HV and ≤ 390 HV	> 390 HV
Measures related to IHE	Supplemental process verification with regard to IHE OR Product testing OR Baking	Supplemental process verification with regard to IHE AND Product testing and/or baking	Supplemental process verification with regard to IHE AND Baking ^a AND Product testing for each manufacturing lot ^b
	At the choice of the fastener manufacturer		—
^a For baking temperature and duration, see B.4 . ^b For alkaline zinc-nickel electroplatings with nickel content of 12 % to 16 %, product testing shall be considered as part of in-process control (not mandatory for each manufacturing lot).			

Table 7 — Measures related to IHE for case-hardened and tempered screws intended to be preloaded

Core hardness	≤ 360 HV	> 360 HV and ≤ 390 HV	> 390 HV
Measures related to IHE	Supplemental process verification with regard to IHE OR Product testing OR Baking	Supplemental process verification with regard to IHE AND Baking ^a	Supplemental process verification with regard to IHE AND Baking ^a AND Product testing for each manufacturing lot ^b
	At the choice of the fastener manufacturer	Product testing solely at the manufacturer's choice	—
^a For baking temperature and duration, see B.4 . ^b For alkaline zinc-nickel electroplatings with nickel content of 12 % to 16 %, product testing shall be considered as part of in-process control (not mandatory for each manufacturing lot).			

When product testing with regard to IHE is performed on case-hardened screws, it shall be in accordance with ISO 15330 or ASME B18.6.3; see also [B.6](#).

4.4.7 Work hardened fasteners and fasteners with threads rolled after heat treatment

For fasteners not intended to be quenched and tempered that are work hardened to high hardness resulting in high residual stress, stress relief prior to electroplating may be necessary. See [B.5](#).

For fasteners with threads rolled after heat treatment (i.e. after quenching and tempering), the measures in [Table 3](#) for fasteners in accordance with ISO 898-1 shall apply without modification, as a local increase of surface hardness by work hardening combined with residual compressive stress have no negative impact on susceptibility to IHE.

4.4.8 Fasteners with bainitic structure

Fasteners with bainitic structure are not addressed in [4.4](#). A written agreement between the supplier and the purchaser with regard to IHE is necessary.

4.5 Baking

When baking is performed, baking conditions including temperature and duration shall be based on fastener material properties, electroplating process, and coating material. See [B.4](#) for more detailed guideline/recommendations.

Baking is usually performed before application of a conversion coating and/or before application of an additional sealant/top coat. In case of passivation (with or without sealant) and depending on baking temperature, baking in the passivated and/or sealed condition may be suitable provided corrosion resistance is not impaired.

NOTE With proper care, many steel fasteners are electroplated without baking by correlating process conditions and coating material to the susceptibility of the fastener material to hydrogen embrittlement, and by applying adequate process control procedures. DIN 50969-2 and ASTM F1940 are recognized methods for process control to evaluate the risk of IHE. These or other similar test methods are used as the basis for determining if baking is required.

However, prevention of the risk of IHE does not only depend on baking (see [4.4](#) and [Annex B](#)).

5 Corrosion protection and testing

5.1 General

The corrosion protection of an electroplated coating system depends to a considerable extent on the thickness of the metal layer(s). Conversion coatings and/or sealants and/or top coats on zinc, zinc-iron, zinc-nickel and cadmium coatings provide protection against coating metal corrosion (formation of white corrosion), thus providing additional protection against basis metal corrosion.

Metallic coatings such as zinc, zinc alloys and cadmium are less electropositive than the steel basis metal, which is the condition to provide cathodic protection. In contrast, metals more electropositive than the steel basis metal (e.g. nickel, copper, silver) cannot provide cathodic protection, which can intensify corrosion of the fastener if the coating is damaged or pitted.

The frequency and duration of wetting and service temperatures, contact with corrosive chemicals, and contact with other metals and materials (galvanic corrosion/contact corrosion), can influence the protective performance of coatings.

Corrosion resistance is a product characteristic that can be reduced as a consequence of the following factors:

- physical damage to the coating from handling and transportation, and
- oxidation of the coating or reaction with the environment during transportation and storage.

Before selecting a coating system, all functions and conditions of the assembly should be considered and not just the fastener; see [Annex A](#). An appropriate choice for a given application should be made between the purchaser and the fastener supplier and/or the coater and/or the chemical supplier.

Corrosion resistance in accelerated corrosion tests (e.g. neutral salt spray test, sulfur dioxide test) cannot be directly related to corrosion protection behaviour in service environments. However, accelerated tests are commonly used to evaluate the corrosion resistance of the coating system.

5.2 Neutral salt spray test (NSS) for zinc-based coating systems

The neutral salt spray test (NSS) in accordance with ISO 9227 is used to evaluate the corrosion resistance of the coating system.

When evaluation of the cabinet corrosivity is requested, it should be performed in accordance with [Annex E](#).

The NSS test in accordance with ISO 9227 shall be used to monitor the consistency of the process by quantifying corrosion resistance on sample fasteners taken periodically from the electroplating process (i.e. in-process control). For these reasons, the NSS test shall be carried out on sample fasteners in the “as-coated” condition. The “as-coated” condition is defined as the condition after completion of all steps of coating (including application of any sealant, top coat or lubricant) without the occurrence of damages from the factors listed in [5.4](#), i.e. before any sorting, packaging, transportation or storage.

Purchasers often wish to conduct their own NSS testing on fasteners they receive, to evaluate corrosion resistance and/or for supplier monitoring. In such cases, corrosion resistance is evaluated in the “as-received” condition, i.e. after the occurrence of possible damages from sorting, packaging, transportation and/or storage.

When NSS testing of fasteners is performed in the “as-received” condition, the values of [Table 8](#) are not applicable. They should rather serve as a starting basis, and the factors that cause a reduction of the corrosion resistance should be taken into account, see [5.4](#).

The NSS test duration specified in [Table 8](#) for coating systems with Cr(VI)-free passivations shall apply to fasteners in the “as-coated” condition and shall be carried out no sooner than 24 h after coating. For NSS test duration of zinc coating systems with chromate conversion coatings, see [Annex C](#).

Contact points of fasteners with a holding fixture, if any, shall not be considered in the evaluation of the corrosion test.

Fasteners with one or more captive washer(s) have areas between the mating fastener and washer and/or between the washers with less coating thickness, due to intrinsic electrochemical deposition behaviour. This is similar for fasteners with blind holes. Both result in reduced corrosion resistance in these areas during the corrosion test and should not be cause for rejection. In service, these areas are normally not exposed to environmental corrosion.

NOTE For fasteners intended to be subjected to a high level of plastic deformation after coating (crimping, riveting, etc.), corrosion resistance is reduced in the deformed area.

Table 8 — Corrosion resistance for commonly used zinc and zinc alloy coating systems

Zinc based coating system	Code (see Table 11)	Minimum neutral salt spray test duration ^a for barrel coating ^b h			
		No coating metal corrosion (white corrosion)	No basis metal corrosion (red rust)		
			Coating thickness		
			5 µm	8 µm	12 µm
Zn, transparent passivated ^c	Zn/An/T0	8	48	72	96
Zn, iridescent passivated ^c	Zn/Cn/T0	72	120	192	240
Zn, iridescent passivated, sealed ^c	Zn/Cn/T2	120	168	240	288
Zn, black passivated, sealed	Zn/Fn/T2	24 ^d	72	144	192
ZnFe, iridescent passivated ^c	ZnFe/Cn/T0	96	144	216	264
ZnFe, iridescent passivated, sealed ^c	ZnFe/Cn/T2	120	216	288	360
ZnFe, black passivated, sealed	ZnFe/Fn/T2	96 ^d	192	240	312
ZnNi, iridescent (silver grey) passivated	ZnNi/Cn/T0	120	480	720	720 ^e
ZnNi, iridescent (silver grey) passivated, sealed	ZnNi/Cn/T2	168	600	720	720 ^e
ZnNi, black passivated	ZnNi/Fn/T0	48 ^d	360	600	720 ^e
ZnNi, black passivated, sealed	ZnNi/Fn/T2	120 ^d	480	720	720 ^e

^a Minimum neutral salt spray test duration shall not be regarded as a direct guide for the corrosion resistance of coated fasteners in all environments where they might be used, see ISO 9227.

^b With a rack electroplating process, the effect of possible damage to coating is reduced and therefore increased corrosion resistance can be achieved.

^c Black spots shall not be cause for rejection because they do not impair corrosion resistance, see [A.1.4.4](#).

^d White haze is not considered as white corrosion, see [A.1.4.2](#).

^e Typically higher corrosion resistance is achieved, however for the purpose of this document, corrosion tests are stopped after 720 h.

See also [7.3](#) for corrosion resistance related to temperature.

5.3 Sulfur dioxide test (Kesternich test)

The sulfur dioxide test in a humid atmosphere (also called Kesternich test) is intended for outdoor building fasteners with zinc-based coating systems. When required, the sulfur dioxide test is used to evaluate the corrosion resistance of the coating systems, and the test shall be carried out with 2,0 litres volume of SO₂. See for example method B of ISO 22479.

This test is used to monitor the consistency of the process by quantifying corrosion resistance on sample fasteners taken periodically from the electroplating process (i.e. in-process control). For these reasons, the sulfur dioxide test shall be carried out on sample fasteners in the “as-coated” condition and no sooner than 24 h after coating.

The “as-coated” condition is defined as the condition after completion of all steps of coating (including application of any sealant, top coat or lubricant) without the occurrence of possible damages from the factors listed in [5.4](#), i.e. before any sorting, packaging, transportation or storage.

The minimum number of cycles shall be agreed between the supplier and the purchaser at the time of the order (i.e. 2, 5, 8, 10, 12, 15 cycles, etc.).

Contact points of fasteners with a holding fixture, if any, shall not be considered in the evaluation of the corrosion test.

Fasteners with one or more captive washer(s) have areas between the mating fastener and the washer and/or between the washers with less coating thickness, due to intrinsic electrochemical deposition

behaviour. This is similar for fasteners with blind holes. Both result in reduced corrosion resistance in these areas during the corrosion test and should not be cause for rejection. In service, these areas are normally not exposed to environmental corrosion.

NOTE For fasteners intended to be subjected to a high level of plastic deformation after coating (crimping, riveting, etc.), corrosion resistance is reduced in the deformed area.

5.4 Bulk handling, automatic processes such as feeding and/or sorting, storage and transport

Bulk handling, automatic processes such as feeding and/or sorting, storage and transport can cause a significant reduction of corrosion protection (especially of protection against coating metal corrosion) depending on the coating system and the type and geometry of the fasteners. This can especially occur for Cr(VI)-free coating systems where less self-healing effect takes place and/or where sealants/top coats are sensitive to impact damage and/or abrasion.

If corrosion protection is to be checked after any of these or similar processes/process steps, an agreement should be reached between the supplier and the purchaser, e.g.:

- reducing the minimum resistance to corrosion in testing,
- adjusting coating parameters,
- increasing the thickness of the coating system, and/or
- selecting another type of electroplated coating system.

6 Dimensional requirements and testing

6.1 General

Before coating, all fastener dimensions shall be within the tolerances specified in product standards or technical specifications.

6.2 Fasteners with ISO metric thread

6.2.1 Coating thickness

Coating thicknesses which can be applied on ISO metric threads in accordance with ISO 965-1, ISO 965-2 or ISO 965-3 depend on the fundamental deviation available, which itself depends on the thread and the following tolerance positions:

- g, f or e for external threads,
- H or G for internal threads.

For more information, see [Annex D](#).

Coating thickness has a significant influence on gaugeability and assemblability, therefore thread tolerance and clearance in the thread shall be considered. The coating shall not cause the zero line (basic size, i.e. h/H) to be exceeded in case of external threads, nor shall it fall below in the case of internal threads; see [D.5](#).

If a coating thickness that exceeds the available clearance is desired, special requirements shall apply; see [Annex D](#).

6.2.2 Gaugeability and assemblability

Coated ISO metric threads shall be gauged with a GO-gauge in accordance with ISO 1502 of tolerance position h for external threads and H for internal threads.

When gauging coated threads of bolts, screws and studs, a maximum torque of $0,001d^3$ (Nm) on a length of $1d$, beginning from thread end, is acceptable. When gauging coated threads of nuts, a maximum torque of $0,001D^3$ (Nm) is acceptable. See [Table 9](#).

Table 9 — Maximum torque for gauging of coated ISO metric threads

Nominal thread diameter <i>d</i> or <i>D</i> mm	Maximum torque for gauging Nm
3	0,03
3,5	0,04
4	0,06
5	0,13
6	0,22
7	0,34
8	0,51
10	1,0
12	1,7
14	2,7
16	4,1
18	5,8
20	8,0
22	11
24	14
27	20
30	27
33	36
36	47
39	59
For other diameters, the torque shall be calculated in accordance with $0,001d^3$ (Nm) or $0,001D^3$ (Nm), and rounded to two significant digits.	

Acceptance procedures for assemblability may be applied by agreement between the supplier and the purchaser:

- for external thread, the use of a suitable nut or the original mating fastener;
- for external thread, the specification of the engaged thread length if more than $1d$;
- for internal thread, the use of a suitable mandrel (e.g. the mandrel specified for proof load in accordance with ISO 898-2) or the original mating fastener.

6.3 Other fasteners

After coating, there is no dimensional requirement in this document for other threaded fasteners and for non-threaded fasteners. For additional information, see [Annex A](#).

6.4 Test methods for thickness determination

One of the following test methods shall be used to determine the local thickness of the metal layer(s):

- X-ray techniques in accordance with ISO 3497;
- coulometric method in accordance with ISO 2177; this method should not be used when additional non-conductive layers are present;
- microscopic method in accordance with ISO 1463 (on any area(s) of the fastener);
- magnetic inductive techniques in accordance with ISO 2178 (before application of any sealant and/or lubricant); this method can also be used to determine the total local thickness;
- eddy current (phase sensitive) testing in accordance with ISO 21968.

In case of dispute, the microscopic method in accordance with ISO 1463 shall be used.

The thickness shall be determined on reference areas as follows:

- for long shaped fasteners (bolts, screws, studs, etc.), any flat surface located at one of their extremities, see [Figure 2 a\)](#);
- for nuts, washers, pins, rivets and other fasteners, any flat surface or other suitable areas, see [Figures 2 b\)](#) and [2 c\)](#).

For fasteners with captive washer(s), the reference area shall be on the threaded fasteners, not on the washer(s). For special fastener shapes, the reference areas shall be agreed.

See also NOTE 2.

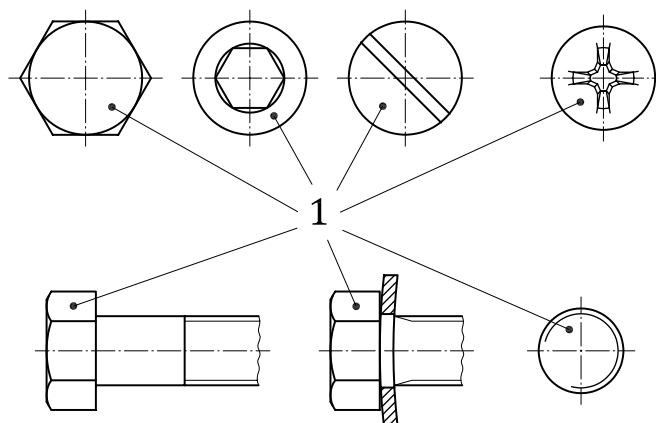

a) Bolts, screws and studs

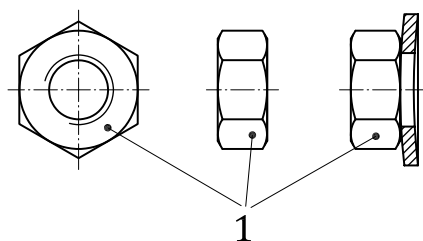

b) Nuts

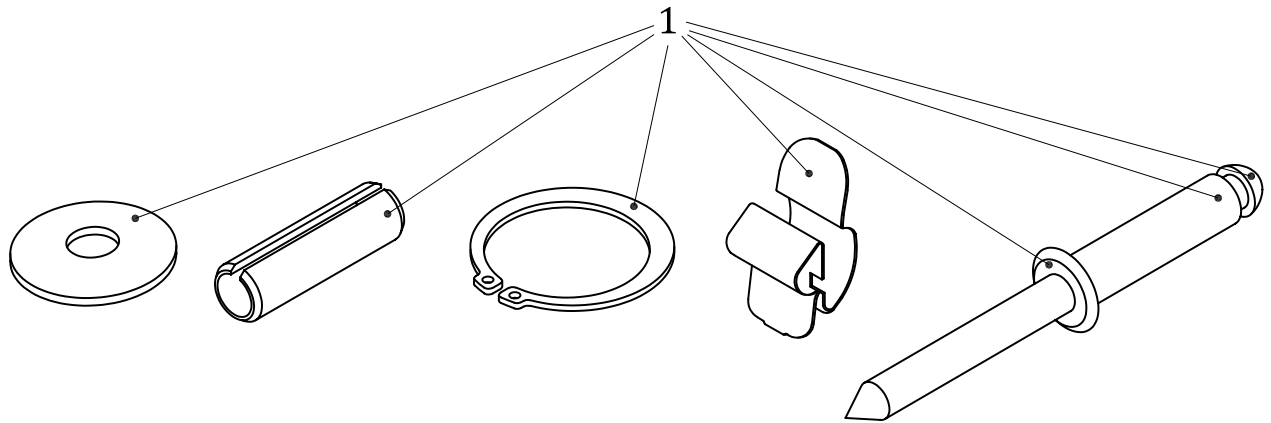

c) Non-threaded fasteners

Key

1 reference areas for local coating thickness determination

Figure 2 — Examples of reference areas for fasteners

For free washers and similar flat fasteners, corrosion resistance specified in [Table 8](#) is decisive. Coating thickness is given for guidance only.

NOTE 1 For more information regarding coating uniformity on washers and similar flat fasteners, see [A.3.4](#).

The coating thickness of the metal layer(s), measured on the reference areas according to [Figure 2](#), shall comply with the minimum values of [Table 10](#). Lower local thickness in a location other than reference areas shall not be cause for rejection.

Table 10 — Coating thickness for the metal layer(s)

Designation for coating thickness	Minimum local thickness on reference areas µm
3	3
5	5
8	8
10	10
12	12
15	15
20	20
25	25
30	30

NOTE 2 Electroplating can result in a non-uniform coating thickness, a phenomenon known as dog bone effect whereby thickness is greater at external edges and reduced in cavities, see [D.3](#). The choice of reference areas in [Figure 2](#) is a consequence of this phenomenon in order to facilitate a reproducible determination of the coating thickness.

7 Mechanical and physical properties and testing

7.1 General

Electroplated coating systems shall comply with the provisions of ISO 1456, ISO 2082, ISO 2093, ISO 4521 or ISO 15726 (see also [Table 1](#)) for the coating concerned in respect of appearance, adhesion and ductility, together with the requirements specified in [7.2](#) to [7.5](#).

7.2 Appearance

The coated fastener shall be free from blisters, delamination and uncoated areas which can adversely affect the corrosion protection. Local excess of coating (e.g. in case of top coats) shall not impair functional properties (gaugeability, torque/clamp force relationship, etc.).

It is possible to add dyes/pigments to the passivation or chromatisation solution in order to give a coloured aspect to the conversion layer, often used for distinction purposes. Dyes/pigments may also be added to sealants/top coats to obtain coloured surfaces.

Non-homogeneous colour shall not be cause of rejection, unless otherwise agreed between the manufacturer and the purchaser at the time of order.

7.3 Corrosion resistance related to temperature

Elevated temperature can affect the corrosion protection of coated fasteners.

When agreed at the time of the order, the corrosion resistance may be tested after a specified heating cycle. Temperature and duration shall be agreed upon, e.g. 1 h at 120 °C, 24 h at 120 °C, 1 h at 150 °C. For zinc-based coatings, after heating the fasteners at part temperature for a specified cycle, the corrosion resistance requirements specified in [5.2](#) shall still be met.

7.4 Torque/clamp force relationship

When required, torque/clamp force relationship may be determined for fasteners with ISO metric threads with electroplated coating systems including sealants and/or top coats with integral lubricant and/or subsequently added lubricant.

The test method shall be agreed between the supplier and the purchaser, in accordance with ISO 16047 and/or in accordance with other relevant technical specifications.

The requirements for torque/clamp force relationship shall be agreed between the supplier and the purchaser. See [A.2](#) for information.

7.5 Determination of hexavalent chromium

When required, the presence or absence of Cr(VI) shall be determined in accordance with ISO 3613 by using the test solution C2 (destructive). However, for fasteners the surface is not about 50 mm × 50 mm but shall be as close as possible to 2 500 mm².

8 Applicability of tests

8.1 General

All requirements specified in [Clauses 5](#) to [7](#) apply as far as they are general characteristics of the coating. When required by the purchaser, optional testing shall be agreed at the time of the order.

8.2 Tests mandatory for each lot

The following tests shall be carried out for each lot of fasteners:

- coating thickness (see [6.4](#));
- gaugeability/assemblability of fasteners with ISO metric thread (see [6.2.2](#));
- assemblability for other fasteners (see [6.3](#));
- appearance (see [7.2](#)).

8.3 Tests for in-process control

The following tests are not intended to be applied for each fastener lot but shall be used for in-process control (see ISO 16426), when relevant:

- corrosion resistance: NSS test (see [5.2](#));
- in accordance with [4.4](#), supplemental process verification with regard to IHE.

8.4 Tests to be performed when specified by the purchaser

The following tests are performed when specifically required by the purchaser. In-process control (see [8.3](#)) may be used to supply test results to the purchaser:

- corrosion resistance: NSS test (see [5.2](#)) or alternatively and only when specifically required, sulfur dioxide test (see [5.3](#));
- temperature resistance (see [7.3](#));
- torque/clamp force relationship (see [7.4](#));
- determination of presence or absence of hexavalent chromium (see [7.5](#)).

9 Designation system

9.1 General

A coating system can be built-up by a number of layers as shown in [Table 11](#). However, not all layers need to be present; see [Figure 1](#).

Table 11 — Key to designation for electroplated coating systems

Element	Description	Symbol	Designation
Basis metal	Steel		
Metal layer(s)	Zinc	Zn	Table 12
	Zinc-nickel	ZnNi	
	Zinc-iron	ZnFe	
	(for other metal layers, see Table 1)		
Conversion coating (passivation)	Transparent	An	Table 13 ^a
	Iridescent	Cn	
	Black	Fn	
	Yellow	Gn	
	No conversion coating	U	
Sealant/top coat	Sealant (see also A.1.3)	T2	Table 15
	Top coat (see also A.1.3)	T7	
	No sealant, no top coat	T0	
	No lubricant	nL	
Additional lubricant	Subsequently added lubricant	T4	Table 15
^a For chromate conversion coatings, see Table 14 .			

9.2 Designation of electroplated coating systems for the order

The designation of the coating shall be added to the fastener designation in accordance with the designation system specified in ISO 8991. The electroplated coating system shall be designated in accordance with [Table 11](#) and in the same order. A slash (/) shall be used to separate data fields in the coating designation. See examples in [9.3](#).

NOTE The obsolete designation codes according to ISO 4042:1999¹⁾ are given in [Annex F](#) for information only.

For other electroplated coatings, the designation shall be in accordance with the relevant standards referenced in [Table 1](#).

When a stress relief process and/or baking is required, it shall not be included in the designation but be specified separately.

If the composition of the sealant, top coat and/or subsequently added lubricant is important in relation to the intended use, the purchaser and the supplier shall explicitly agree on their chemical contents at the time of the order.

1) Withdrawn.

Table 12 — Designation for electroplated coating systems in ordering fasteners

Electroplated coating system			Neutral salt spray test duration (red rust) ^c	Torque/clamp force specification, ^d if any	
Coating material	Metal layer(s) Thickness ^c	Conversion coating			Sealant, top coat and/or lubricant
Zn	In accordance with Table 10	In accordance with Table 13 or 14	In accordance with Table 15	e.g. 480 h	μ_{tot} [specified range] or K [specified range]
ZnNi ^a					
ZnFe ^b					

^a Zinc-nickel electroplated coatings for fasteners have a typical content of 12 % to 16 % nickel by mass and are designated by ZnNi(12) in ISO 15726. If further nickel content is desired, see ISO 15726.

^b Zinc-iron alloys are specified as 0,3 % to 1 % of iron by mass.

^c Thickness can be replaced by minimum neutral salt spray test duration in accordance with [Table 8](#): in this case, thickness shall be omitted in the coating system designation, and corrosion resistance shall be added at the end of the designation; see [9.3](#), Example 1.

^d The reference test method (e.g. ISO 16047) and options shall additionally be specified at the time of the order; see also [7.4](#) and [A.2.1](#).

Table 13 — Designation for hexavalent chromium free conversion coatings (only for zinc and zinc-alloy electroplated coatings)

Passivation ^a		Typical aspect
Code ^b	Name	
An	Transparent	Transparent, clear to bluish ^c
Cn	Iridescent ^d	Transparent, clear to iridescent
Fn	Black	Black, dark iridescent permitted
Gn	Yellow	Yellow to yellow iridescent
U	—	No conversion coating

^a Nanoparticles may be incorporated in all types of passivation to improve the aspect and/or functional properties.

^b The first letter corresponds to the type of conversion coating; the second letter (n) indicates no hexavalent chromium in the conversion coating.

^c Bluish can vary from light-blue to dark iridescent blue, depending on the coating system.

^d Also called thick layer passivation.

Table 14 — Designation for hexavalent chromium conversion coatings (only for zinc and zinc-alloy electroplated coatings)

Chromate conversion coating		Typical aspect
Code	Name	
A	Clear	Transparent, clear to bluish
C	Iridescent	Yellow iridescent
D	Opaque	Olive-green
F	Black	Black, dark iridescent permitted
U	—	No conversion coating

Table 15 — Designation for sealants, top coats and/or lubricants

Code	Name	Requirement
—	When no code T is specified, sealant or top coat can be applied at the choice of the coater.	
T0	No sealant and no top coat	No sealant or top coat shall be applied (e.g. for applications where better adherence, conductivity, electrical contact or welding is needed).
T2	Sealant ^a	Sealant shall be applied, it may be with or without integral lubricant ^b .
T4	Subsequently added lubricant ^c	Lubricant or wax shall be applied. Lubricant can be applied directly on the metal layer, or on the passivation, sealant or top coat.
T7	Top coat ^a	A top coat shall be applied. Top coat is often used to achieve particular characteristics, e.g. chemical resistance, colour. Top coat may be with or without integral lubricant ^b .
nL	No lubricant	No integral lubricant shall be applied (this code shall be added to T2 or T7, as relevant).
NOTE For more information about sealants and top coats, see A.1.3 .		
^a Sealant and top coat may be organic or inorganic, or a combination of both.		
^b When torque/clamp force relationship (e.g. range of friction coefficient) is specified, integral lubricant or subsequently added lubricant shall be applied as appropriate.		
^c When a subsequently added lubricant is specified, the code T4 shall be placed after a slash and directly after the designation of the sealant or top coat; see 9.3 , Example 4.		

9.3 Examples of designation of hexavalent chromium free electroplated coating systems for fasteners

When a minimum corrosion resistance is specified in the designation, the compatibility of the requirement with the coating system included in the designation shall be checked in accordance with [Table 8](#).

EXAMPLE 1 Fastener with an electroplated coating (ISO 4042) of zinc-nickel alloy (ZnNi) with the typical nickel content of 12 % to 16 %, without required coating thickness but with a minimum corrosion resistance to neutral salt spray test of 720 h without occurrence of basis metal corrosion (red rust), with a hexavalent chromium free iridescent conversion coating (Cn), with no specific sealant, top coat or lubricant, is designated as follows:

[fastener designation] – **ISO 4042/ZnNi/Cn/720h**

EXAMPLE 2 Fastener with an electroplated coating (ISO 4042) of zinc (Zn) and a required coating thickness of 8 µm, with hexavalent chromium free transparent passivation (An), is designated as follows:

[fastener designation] – **ISO 4042/Zn8/An**

EXAMPLE 3 Fastener with an electroplated coating (ISO 4042) of zinc (Zn) and a required coating thickness of 12 µm, with a hexavalent chromium free iridescent conversion coating (Cn), with a subsequent sealant with or without integral lubricant (T2), is designated as follows:

[fastener designation] – **ISO 4042/Zn12/Cn/T2**

EXAMPLE 4 Fastener with an electroplated coating (ISO 4042) of zinc (Zn) and a required coating thickness of 12 µm, with a hexavalent chromium free black conversion coating (Fn), with a subsequent top coat (T7), with a subsequently added lubricant (T4), and with a coefficient of friction μ_{tot} within the range of 0,10 to 0,20, is designated as follows:

[fastener designation] – **ISO 4042/Zn12/Fn/T7/T4(μ_{tot} 0,10–0,20)**

EXAMPLE 5 Fastener with an electroplated coating (ISO 4042) of zinc (Zn) and a required coating thickness of 8 µm, with a hexavalent chromium free iridescent conversion coating (Cn), where a subsequent sealant is prohibited (T0), is designated as follows:

[fastener designation] – ISO 4042/Zn8/Cn/T0

EXAMPLE 6 Fastener with an electroplated coating (ISO 4042) of zinc (Zn) and a required coating thickness of 8 µm, with a hexavalent chromium free black conversion coating (Fn), where a subsequent sealant is left to the choice of the coater, is designated as follows:

[fastener designation] – ISO 4042/Zn8/Fn

EXAMPLE 7 Fastener with an electroplated coating (ISO 4042) of zinc-nickel alloy (ZnNi) with the typical nickel content of 12 % to 16 % and a required coating thickness of 8 µm, with a hexavalent chromium free iridescent conversion coating (Cn), and with no specific sealant, top coat, lubricant or torque/clamp force requirement is designated as follows:

[fastener designation] – ISO 4042/ZnNi8/Cn

9.4 Designation of fasteners with electroplated coating systems for labelling

At least the following information shall be added to labelling, separated by a slash (/):

- ISO 4042 for the electroplated coating system in accordance with this document;
- the material of the coating, and the thickness of the metal layer(s) or minimum neutral salt spray test duration in accordance with [Table 8](#);
- the conversion coating in accordance with [Table 13](#) (the suffix n indicating that it does not contain hexavalent chromium) or with [Table 14](#);
- the sealant, top coat and/or subsequently added lubricant, if any, in accordance with [Table 15](#).

EXAMPLE 1 [fastener designation] – ISO 4042/ZnNi8/Fn/T7/T4

EXAMPLE 2 [fastener designation] – ISO 4042/ZnNi/Fn/T7/T4/720h

10 Ordering requirements for electroplating

When ordering an electroplated coating system for fasteners in accordance with this document, the following information shall be supplied:

- a) The reference to this document (ISO 4042:2022);
- b) The coating designation (see [Clause 9](#));
- c) The properties of the fasteners relevant for the coating process, e.g. basis metal, surface condition, hardness, tensile strength and/or property class;
- d) The stress relieving conditions, if any, for stress relieving prior to electroplating;
- e) For fasteners with ISO metric thread, the specific thread tolerance of the non-coated fastener within a thread tolerance position, if any (after coating and in accordance with [6.2.2](#), the tolerance position h/H applies);
- f) The requirement, if any, for precautions to be taken against the risk of IHE, e.g. baking (see [4.4](#) and [4.5](#));
- g) The requirements for torque/clamp force relationship, if any, and related test method (e.g. ISO 16047), as agreed between the supplier and the purchaser;
- h) Other requirements, if any (e.g. specific chemical composition of the sealant, top coat and/or lubricant, chemical resistance, suitability for adhesives, electrical conductivity/insulation);

- i) The additional tests to be carried out, if any (see [8.4](#)) and related sampling;
- j) Requirements for test report, if any, in accordance with ISO 16228.

11 Storage conditions

Storage conditions shall not impair the torque/clamp force properties and corrosion resistance of the coated fasteners (see also [A.4](#)).

Annex A (informative)

Design and assembly aspects for joints with coated fasteners

A.1 Design

A.1.1 General

Before selecting a coating system and in addition to the fasteners themselves, the assembly process, the function(s) of the joint, the service environment, etc. should be considered; see [A.2.2](#). The purchaser should consult the supplier to determine the appropriate selection for a given application.

Today, Cr(VI) is widely restricted. It is therefore recommended to use exclusively Cr(VI)-free conversion coatings (passivations) for new applications.

For sealants and top coats (see [A.1.3](#)), an integral lubricant or a subsequently added lubricant may be chosen to achieve torque/clamp force properties. Sealants and top coats may be chosen to increase corrosion resistance and to achieve other specific properties and/or performances (e.g. chemical resistance, mechanical resistance, impact/abrasion resistance, aspect, colour, thermal resistance, electrical insulation/conductivity, UV resistance).

A.1.2 Coating process

Electroplated coating systems can be applied in bulk process using barrels or in rack process. Top coats are usually applied using a dip-spin process.

Electroplating for fasteners is generally a mass process. When lots of small quantities are to be coated, a suitable coating line and/or process can be necessary to achieve the required properties and performances for the coated fasteners. For fasteners of large size or mass, or when the risk of thread damage is to be reduced or avoided, rack processing instead of bulk/barrel processing should be considered.

When top coats are applied, the curing process (especially with higher temperature and/or longer duration) can have a detrimental effect on the properties/performances of fasteners, e.g.

- for work hardened fasteners,
- for fasteners with thread rolled after heat treatment where intentionally introduced residual stress may be reduced,
- for prevailing torque nuts with non-metallic insert.

A.1.3 Sealants and top coats

Sealants and/or top coats are generally intended to improve the corrosion resistance of zinc-based coating systems. However, both show different characteristics:

- A sealant is usually applied in the wet state without drying prior to its application. This allows the sealant to be partly incorporated in the passivation layer forming a composite layer, which improves corrosion resistance. Sealants are also used for several other purposes such as lubrication, reduction of the iridescence of passivation layers, matting or brightening effect, etc. The layer thickness is typically about 0,5 µm to 2 µm.

- A top coat is usually applied in the dry state after an intermediate drying step. Top coats are often used when particular requirements shall be met, such as incorporation of pigments to achieve intensive colour (e.g. black), high chemical resistance, etc. The layer thickness is typically about 2 µm to 10 µm.

Additional layers such as sealants, top coats and/or lubricants can accumulate in holes, recesses, internal drives, cavities and at thread roots.

The selection of the nature of a sealant or top coat should be based on desired additional properties; see [A.2.2](#).

A.1.4 Possible effects of coating corrosion on appearance

A.1.4.1 General

Neutral salt spray testing in accordance with ISO 9227 leads to two kinds of corrosion products:

- coating corrosion of the zinc or zinc alloy layer, generally known as white corrosion (or “white rust”);
- basis metal corrosion, generally known as red rust.

Further optical changes can occur in the initial phase of corrosion testing, such as a slight whitish film known as white haze (or “grey veil”), or such as black spots.

A.1.4.2 White haze

White haze results from slight reaction of the test media with the zinc, mainly occurring in natural micro-cracks of the metal layer and/or the passivation layer. In case of zinc-nickel alloy layers, white haze stops further corrosion and is considered to be the condition for the high corrosion resistance.



a) Zinc-nickel after 72 h NSS testing



b) Zinc-nickel after 1 000 h NSS testing

Figure A.1 — Examples of white haze in dry state

Typically white haze appears on zinc-nickel layers without or with transparent or iridescent passivation after about 24 h to 72 h of corrosion testing; see [Figure A.1 a](#)). White haze can also appear on non-alloyed zinc layers as well as zinc-iron or zinc-nickel alloy in combination with a black passivation layer after about 24 h to 120 h of corrosion testing.

White haze may increase over time during the test duration (see [Figure A.1 b](#))). It is not voluminous and is not visible in the wet state, but only on dry parts; see [Figure A.2](#).



a) Part in wet state



b) Part in dry state

Figure A.2 — Examples of white haze on a zinc-nickel layer after 720 h NSS testing in wet and dry state

White haze is a natural phenomenon in particular for zinc-nickel layers and should be accepted. In case of higher requirements to cosmetic/decorative appearance, a written agreement between the purchaser and the supplier is recommended.

A.1.4.3 White corrosion

In contrast to white haze, white corrosion of zinc and zinc alloy layers results from extensive corrosion of the coating metal, is more voluminous and can be already identified in the wet state of the parts; see [Figures A.3](#) and [A.4](#).



a) White corrosion of iridescent passivated zinc layer after 240 h NSS testing



b) Severe white corrosion of iridescent passivated zinc layer after 480 h NSS testing

Figure A.3 — Examples of white corrosion

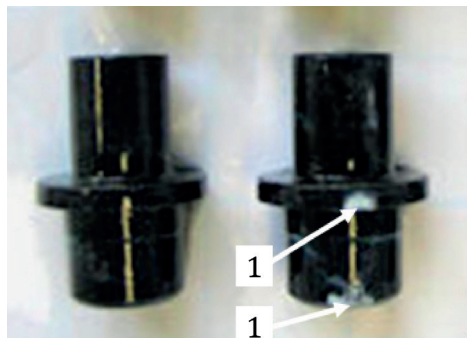

**a) Parts in wet state
(only white corrosion is visible)**

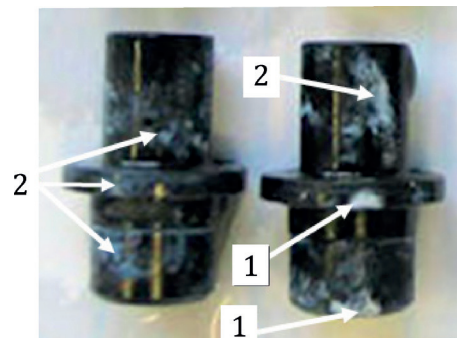

**b) Same parts in dry state
(white haze and white corrosion visible)**

Key

- 1 white corrosion
- 2 white haze

Figure A.4 — Examples of white corrosion and white haze on a zinc layer with black passivation and transparent sealant after 240 h NSS testing

A.1.4.4 Black spots

Black spots can appear during accelerated corrosion testing before initial occurrence of coating corrosion; see [Figure A.5](#). Main root cause are micro-defects of the basis metal and/or the coating metal. Corrosion media can migrate or be entrapped in the basis metal and can cause corrosion under lack of oxygen, forming black corrosion products.

NOTE 1 Other root causes for black spots exist but are not fully investigated at this time.

Black spots shall not be cause for rejection because they do not impair corrosion resistance and do not typically appear under service conditions.

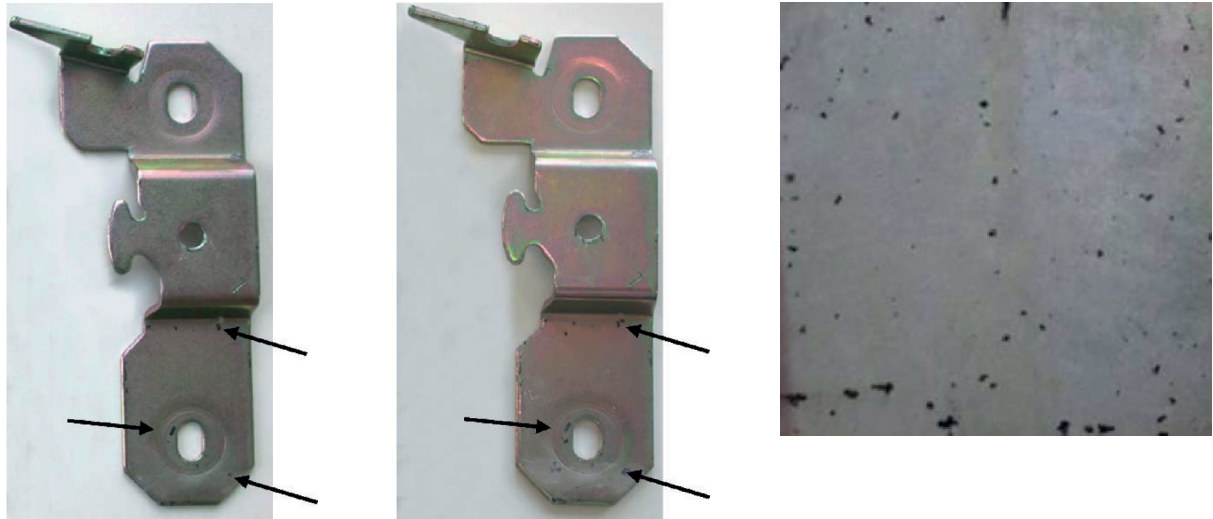

a) Part after 168 h
NSS testing

b) Same part after 408 h
NSS testing

c) Typical black spots

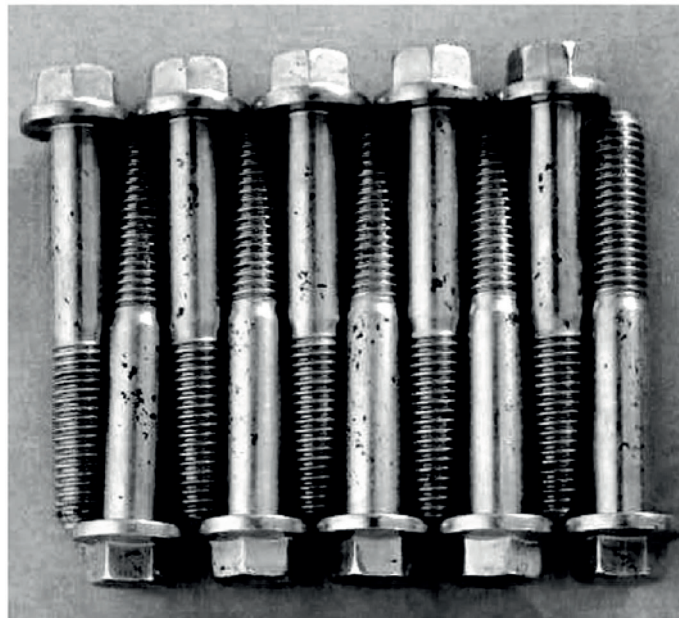

d) Black spots after 240 h NSS test of fasteners with iridescent passivated zinc layer

Figure A.5 — Examples of black spots on a zinc layer with iridescent passivation after NSS testing

NOTE 2 Arrows in [Figure A.5](#) a) and b) indicate black spots.

A.2 Functional properties

A.2.1 Assemblability and mountability

In case of applying an additional top coat, sealant or lubricant by a dip-spin process, assemblability and mountability should not be impaired, such as dimensional tolerances of the functional parts of the fasteners, tool gripping (e.g. for retaining rings), tool insertion (e.g. for recess and internal drives), or by interference with clearance holes.

For dimensional requirements after coating for ISO metric threads, see [6.2](#) and [Annex D](#).

The compatibility of the coating system with the tightening process should be considered, especially with high-speed tightening e.g. 100 min⁻¹ and above (risk of overheating, increase, decrease or scattering of friction coefficients, stick/slip, etc.).

In addition, the compatibility of the coated fasteners with the clamped parts, e.g. tapped holes, clamped parts in aluminium, magnesium, stainless steel, parts with electrophoretic coating, hot dip galvanized parts, plastic, wood, should be considered.

For fasteners with ISO metric thread, at least one of the mating threaded fasteners should be lubricated for a consistent torque/clamp force relationship in order to achieve a specific clamp force. Electroplated coating systems provide lubricated solutions (see [A.1.1](#)). Torque/clamp force relationship can be determined in accordance with ISO 16047 and expressed as a coefficient of friction μ_{tot} or by means of a *K*-factor.

A.2.2 Other properties of joints with coated fasteners

A.2.2.1 Chemical resistance

If chemical resistance is required, organic top coats applied on electroplated coatings are typically more resistant against acids and alkaline chemicals than inorganic top coats or sealants.

A.2.2.2 Electrical conductivity

The electrical conductivity of electroplated coating systems with a sealant is generally sufficient for application of electrophoretic coatings and antistatic purposes. Electroplated coatings in combination with sealants and top coats are usually not suitable for electrical grounding.

Also lubricants are not always suitable for electrical grounding; the lubricant manufacturer should be consulted for suitability.

A.2.2.3 Galvanic corrosion

In order to reduce the risk of galvanic corrosion, all parts of the joint should be considered (coated fasteners and clamped parts). A direct metal contact of coated fasteners with non-coated clamped parts should be avoided, especially for stainless steel, aluminium, magnesium, copper or copper alloys, carbon fibre materials, and carbon filled rubber. Due to their higher insulating effect, organic top coats can improve the resistance against galvanic corrosion.

The most suitable measure to reduce the risk of galvanic corrosion is to select a coating or coating system for the fastener with the same or a similar electrical potential compared to the clamped parts.

A.2.2.4 Cleanliness

For cleanliness requirements, the suitability of the electroplated coating system should be checked (e.g. dust, particle size, particle type, number of particles, applicability of cleanliness test methods).

A.3 Particular issues related to fasteners and coating processes

A.3.1 General

The type of fasteners should be considered when choosing a coating system and related coating process: [A.3.2](#) to [A.3.9](#) list the main issues for each type of fasteners. Suitable measures should be taken into account for the following types of fasteners, and potential issues should be considered.

When sorting is required for one or more specific selected characteristic(s), agreement should be reached between the purchaser and the supplier.

A.3.2 Fasteners with ISO metric thread

Main issues to be considered are:

- thread damages (the heavier the part, the more sensitive it is);
- filling of drives/recesses and internal threads in case of an application of top coats;
- particles in threads;
- contamination with foreign parts.

For electroplated fasteners with pitch $P < 1$ mm to be coated with an additional top coat, a special agreement between the supplier and the purchaser should be reached.

A.3.3 Fasteners with captive washer(s)

Main issues to be considered are:

- retention of particles (e.g. when shot blasting is used as pre-treatment);
- non-uniform coating deposition with lower local thickness due to the tendency of sticking to their mating fastener during a barrel electroplating and dip-spin processes (e.g. for sealants or top coats);
- contamination with foreign parts.

A.3.4 Washers and similar fasteners

Free washers and similar fasteners (especially with flat bearing surfaces and/or low weight) tend to stick together during barrel electroplating and dip-spin processes (e.g. for sealants or top coats). This can result in a non-uniform coating deposition with lower local thickness and can cause lower corrosion resistance. Special application techniques may be necessary to avoid or reduce the risk of sticking.

A.3.5 Fasteners with adhesive or patch

Main issues to be considered are:

- applicability of adhesive or patch to the selected electroplated coating system;
- functional properties (lack of adhesion, impairment of torque/clamp force relationship);
- reduction of corrosion resistance (e.g. elevated temperature application/curing temperature);
- performance of adhesive or patch in combination with lubricated coating systems.

A.3.6 Prevailing torque nuts

For all metal prevailing torque nuts, electroplated coating systems in combination with silicate-based sealants or top coats can cause increased friction in the engaged thread up to galling during tightening; an alternative sealant or top coat and/or an additional lubricant should be used for such applications.

For prevailing torque nuts with non-metallic insert, a possible detrimental effect of the curing temperature (e.g. in case of organic top coats) should be considered.

A.3.7 Fasteners with recess, internal drive, cavity or hole

Especially for small fasteners, special techniques can be necessary to prevent retention of particles (e.g. when shot blasting is used as pre-treatment) and excess of coating in recesses, internal drives, cavities or holes (blind or clearance holes) in case of additionally applied top coats.

A.3.8 Screws which form their own mating thread

When selecting electroplated coating systems, the requirements for thread-forming properties should be considered, e.g. for metric thread-forming screws, tapping, self-drilling, chip board screws as well as screws for plastics.

A.3.9 Clips and retaining rings

The main issues to be considered are:

- tangling and damages of clips and retaining rings should be avoided during the coating process;
- special techniques can be necessary to prevent retention of particles and/or excess of coating in case of an additionally applied top coat.

A.4 Storage of coated fasteners

During storage and before installation, direct contact with water or other liquids, condensation, exposure to dust, etc. should be avoided; such conditions can impair torque/clamp force relationship and/or corrosion resistance.

Annex B (informative)

Hydrogen embrittlement consideration

B.1 General

A typical definition for Hydrogen Embrittlement (HE) in literature and standards is as follows:

A permanent loss of ductility in a metal or alloy caused by hydrogen in combination with tensile stress, resulting from externally applied load and/or internal residual tensile stress.

Hydrogen Embrittlement, also called Hydrogen Assisted Cracking (HAC), is classified under two categories based on the source of hydrogen: Internal Hydrogen Embrittlement (IHE) and Environmental Hydrogen Embrittlement (EHE). IHE is triggered by residual hydrogen from steelmaking or from processing steps such as pickling and electroplating. EHE is triggered by hydrogen introduced into the metal from external sources while it is under tensile stress, e.g. in the case of in-service fasteners. The term Stress Corrosion Cracking (SCC) is commonly used to define EHE that occurs when hydrogen is present in a corrosive environment and/or produced as a by-product of surface corrosion and is absorbed by the steel fastener.

Measures to prevent IHE do not eliminate the risk of EHE when a susceptible fastener is exposed to corrosion generated hydrogen. See ISO/TR 20491 for more detailed information about hydrogen embrittlement of fasteners.

B.2 Conditions for hydrogen embrittlement failure

For Hydrogen Embrittlement failure to occur, the three following conditions are **concurrently** necessary:

- **material condition that is susceptible** to hydrogen damage (root cause of hydrogen embrittlement),
- **tensile stress** (typically the result of an applied load, including residual tensile stress),
- **atomic hydrogen**.

See HE in [Figure B.1](#).

If all three of these elements are present in sufficient quantities and given time, hydrogen damage results in crack initiation and growth until the occurrence of delayed fracture. Time to failure can vary, depending on the severity of the conditions and the source of hydrogen.

NOTE IHE failures occur within hours after installation, typically less than 72 h.

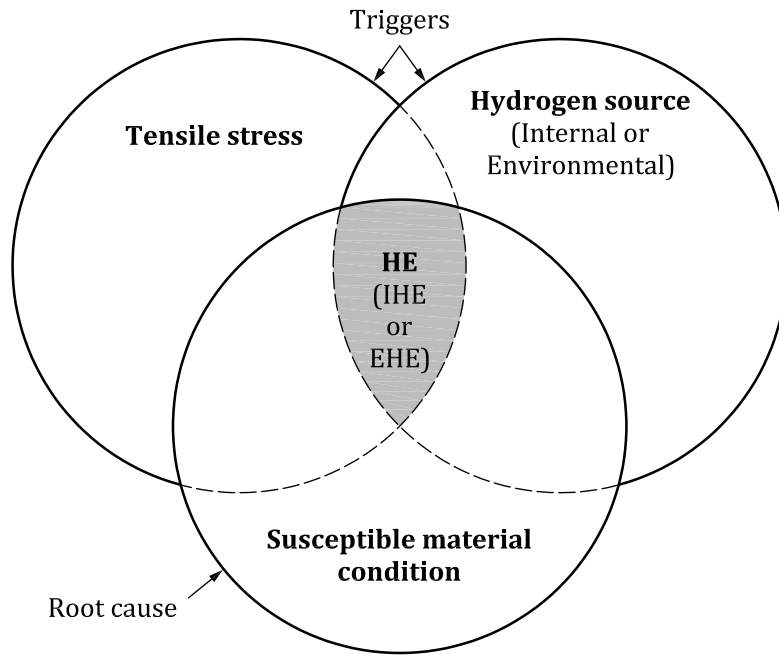

Figure B.1 — Confluence of the three necessary conditions for Hydrogen Embrittlement (HE) failure to occur

B.3 Electroplating and Internal Hydrogen Embrittlement (IHE)

The most relevant manufacturing processes to consider with respect to IHE are primarily coating processes and related surface cleaning and preparation processes (e.g. pickling). These processes are significant because they are typically the final manufacturing step, and the coating materials (e.g. zinc) act as a barrier to hydrogen effusion.

Electroplating processes generate hydrogen; however, the amount of hydrogen absorbed by the fasteners is not directly related to the quantity of hydrogen generated. The amount of hydrogen which may be absorbed depends on the process type (e.g. alkaline zinc, acid zinc, zinc alloy) and process parameters (e.g. current density, electroplating time, rack/barrel electroplating). The most important factor that influences the quantity of hydrogen that remains in a fastener is the permeability of the coating to hydrogen effusion. The permeability of the coating determines if it allows hydrogen to effuse outward or if the coating is an effective barrier that blocks hydrogen effusion, thus forcing it to stay in the steel.

Typical cleaning for electroplating comprises hot alkaline cleaning followed by acid pickling and anodic electrolytic alkaline cleaning. Acid pickling is a significant source of hydrogen in coating processes. As a matter of good practice, the use of a suitable inhibitor is recommended, and pickling duration should not exceed the time required for adequate surface preparation.

For fasteners with hardness above 390 HV, such as bolts, screws or studs with property class 12.9/12.9, special pre-treatments are advisable using non-acidic methods such as mechanical cleaning (e.g. dry honing, shot blasting) or alkaline cleaning. However, for small size fasteners (e.g. below M6), fasteners with captive washer(s), with small internal drive/recess, with internal thread, acid cleaning could be the only method that works. For some non-threaded fasteners produced from spring steels subjected to high tensile stress (e.g. spring pins, conical washers, retaining rings), any alternative process that does not introduce hydrogen in the steel is recommended.

Studies have shown that there is no risk of IHE for phosphate coated property class 12.9/12.9 fasteners when left at ambient temperature for more than 24 h, because phosphate coatings are very porous enabling absorbed hydrogen to effuse easily.

Similarly, studies have shown that the risk of IHE is significantly lower for alkaline zinc-nickel coatings containing 12 % to 16 % nickel compared to pure zinc coatings. One of the reasons is that zinc-nickel coatings (ZnNi) are more permeable than zinc (Zn) or zinc-iron (ZnFe) coatings.

For aerospace applications, specific “Low Hydrogen Embrittlement” zinc-nickel (LHE-ZnNi) processes have been developed to replace “Low Hydrogen Embrittlement” cadmium (LHE-Cd) coatings.

NOTE “Low Hydrogen Embrittlement” is a made-up term to express a low risk of HE for such coatings in case of absorbed hydrogen.

The susceptibility to IHE of case hardened fasteners depends not only on core hardness, but also on variables such as case hardness and case depth. The susceptibility to IHE increases as these variables increase. The geometry/shape can also impact the susceptibility as there could be no distinct transition area from high case hardness to the lower hardness in the core in thin sections such as in a flange, see ISO/TR 20491. The greater proportion of the case depth in thin sections is the cause of a higher susceptibility. However, the criterion for baking is based on core hardness, as it has the most significant effect on susceptibility.

Unintended surface discontinuities (e.g. pits that can arise from over-pickling, or laps) can act as localized stress concentrators that intensify the stress condition, particularly for a material that is already susceptible to hydrogen embrittlement.

B.4 Baking

The key factors that influence baking effectiveness are:

- temperature,
- duration,
- permeability of the coating,
- coating thickness.

For susceptible fasteners (e.g. with hardness/core hardness above 390 HV) that are zinc electroplated, 8 h to 10 h at 190 °C to 220 °C are typical baking durations and temperatures. However:

- depending on type, size and hardness/strength level of the fasteners in combination with coating system, coating thickness, coating process, permeability of the coating and baking temperature, shorter durations are successfully applied;
- depending on type, size and hardness/strength level of the fasteners, baking durations up to 24 h can be required to sufficiently reduce diffuse hydrogen.

The common practice of baking zinc electroplated fasteners (especially with high coating thickness) for 4 h at 185 °C to 195 °C is generally inadequate for desorption of hydrogen because zinc is an effective barrier to hydrogen effusion (it has been shown that it can even be detrimental and can lead to occasional failures). For baking zinc electroplated fasteners to be effective and beneficial, a longer baking duration and/or a higher baking temperature (e.g. at least 200 °C) is recommended.

Property class 10.9 fasteners that are properly manufactured to the material, physical and mechanical requirements specified in ISO 898-1 are not susceptible to fail due to IHE and do not need to be baked. Given the current understanding of baking effectiveness and material susceptibility, it is not the baking that prevents these fasteners from failing. Property class 10.9 fasteners are sometimes baked as a precaution against manufacturing errors or out-of-control processes that could render the material susceptible.

In case of a delayed fracture in the application, all conditions including assembly and service conditions should be investigated, in addition to the fasteners and their manufacturing and electroplating processes.

The maximum temperature and duration used in a baking process are limited by the following considerations: it should not exceed the temperature at which the fasteners were originally tempered, and it should not impair the properties of the coating. Excess of temperature and/or duration can also impair the beneficial effect of thread rolling after heat treatment.

Zinc electroplated fasteners are usually baked at a temperature not higher than 220 °C. Cadmium electroplated fasteners are usually baked to a temperature not higher than 200 °C.

The baking process is typically performed after electroplating and prior to application of a conversion coating and/or sealant and/or top coat, if any. However, other sequences may be suitable depending on the specific properties of surface finishes and the applied coatings.

The time between electroplating and baking should be kept short as a matter of good practice. The intent of such practice is to maximize the extraction of mobile hydrogen. Otherwise, a portion of the mobile hydrogen can become reversibly trapped and more difficult to bake out. This phenomenon has been shown to be relevant for electroplated steels at hardness in the range of 500 HV and above. The often used approach of specifying an exact time between electroplating and baking (e.g. 4 h) is purely subjective. It is intended as a practical operational time-frame and also as a quality assurance mechanism for monitoring good practice. Time between electroplating and baking should not be used as a rigid criterion for acceptability of a fastener lot and it definitely should not be used as the basis for assigning root cause to a fastener failure.

Baking furnace conditions, including methods of loading, duration in the furnace and uniformity of temperature, should be controlled. Achieving a well-founded and effective baking strategy, including the decision whether to bake or not to bake, should be validated by empirical data obtained from tests such as sustained load tests and/or by process qualification methods, e.g. as specified in DIN 50969-2 and ASTM F1940.

For more information about baking, see ISO/TR 20491.

B.5 Stress relief

Stress relief prior to electroplating is not relevant or appropriate for fasteners that are quenched and tempered without further alteration; tempering effectively relieves residual stress.

Residual tensile stress in fasteners that are work hardened after quenching and tempering and prior to electroplating can lead to the initiation of hydrogen assisted microcracks. If the material is susceptible and if there is sufficient hydrogen and if the residual tensile stress resulting from work hardening might exceed the HE threshold stress of the steel, a beneficial preventive measure is to perform a stress relief operation prior to electroplating.

Only operations that cause significant plastic deformation resulting in residual tensile stress such as cold forming, cold bending, cold straightening, and some drilling and welding operations may justify stress relief before electroplating. Standard secondary machining operations such as grinding, turning, tapping and milling are not problematic.

The effectiveness of stress relief increases with increasing temperature and duration. However, the maximum temperature is limited such that the mechanical properties of the fasteners are not impaired.

NOTE Stress relief criteria recommended in ISO 9587 are too broad for fasteners, and therefore not applicable to fasteners.

B.6 Hydrogen embrittlement test methods

Test methods designed to either detect or measure any mechanical loss of strength resulting from the effect of hydrogen always include a time component.

Typically, hydrogen embrittlement testing is performed by means of sustained load tests. Sustained load testing is intended as a post-production (e.g. after electroplating) quality assurance step for

testing high strength fasteners that are susceptible to IHE. Sustained load testing consists of applying a specific static load for a fixed period of time ranging from 24 h to 200 h, depending on the specification. The qualitative nature of the sustained load test is such that a fastener will either pass or fail at the given point in time. There are several methods for sustained load testing. The tests most often used for fasteners are specified in ISO 15330, DIN 50969-2, NASM 1312-2, and ASTM F606/F606M. Other tests developed or agreed to by the manufacturer or purchaser can be used if effective in detecting IHE for particular types of fasteners.

NOTE Sustained load tests are suitable for production testing. Standard sustained load test specifications are not intended nor appropriate for testing parts after removal from service.

Annex C (informative)

Corrosion protection related to zinc coatings with chromate conversion coatings

This annex gives information for typical corrosion resistance of zinc coatings with chromate conversion coatings (containing hexavalent chromium) when tested with neutral salt spray test in accordance with ISO 9227; see [Table C.1](#).

Chromate conversion coatings should not be used for new applications.

Table C.1 — Neutral salt spray corrosion resistance of zinc coatings

Designation code in accordance with this document	Obsolete designation code for coatings	Coating thickness μm	Minimum neutral salt spray test duration for barrel coating		
			Chromate conversion coating designation	No coating metal corrosion ^a (white corrosion)	No basis metal corrosion (red rust)
Zn5/A	Fe/Zn 5c1A	5	A	6	24
Zn5/B	Fe/Zn 5c1B		B	12	36
Zn5/C	Fe/Zn 5c2C		C	48	72
Zn5/D	Fe/Zn 5c2D		D	72	96
Zn5/F	Fe/Zn 5Bk		F	12	—
Zn8/A	Fe/Zn 8c1A		8	A	6
Zn8/B	Fe/Zn 8c1B	B		24	72
Zn8/C	Fe/Zn 8c2C	C		72	120
Zn8/D	Fe/Zn 8c2D	D		96	144
Zn8/F	Fe/Zn 8Bk	F		24	72
Zn12/A	Fe/Zn 12c1A	12		A	6
Zn12/B	Fe/Zn 12c1B		B	24	96
Zn12/C	Fe/Zn 12c2C		C	72	144
Zn12/D	Fe/Zn 12c2D		D	96	168
Zn12/F	Fe/Zn 12Bk		F	24	96
Zn25/A	Fe/Zn 25c1A		25	A	—
Zn25/B	Fe/Zn 25c1B	B			
Zn25/C	Fe/Zn 25c2C	C			
Zn25/D	Fe/Zn 25c2D	D			
Zn25/F	Fe/Zn 25Bk	F			

^a Low coating thickness (i.e. 5 μm and lower) impairs the resistance of the chromate conversion coating.

Annex D (informative)

Coating thickness and thread clearance for ISO metric threads

D.1 General

The applicability of the required coating system to ISO metric threads is limited by the basic deviation of the threads, and hence limited by the pitch diameter, clearance, and tolerance positions.

Dimensional requirements and testing for fasteners with ISO metric thread are specified in [6.2](#).

Electroplated coating processes usually do not produce a uniform distribution of the coating thickness on the whole surface of the fasteners. As the coating thickness has a significant influence on gaugeability, it is necessary to consider thread position, tolerance and clearance in the thread.

When designing fasteners to be electroplated, at least the following should be taken into consideration:

- type and size of the fastener;
- tolerance position of the thread before coating;
- clearance available in the thread (see [D.2](#));
- typical dispersion of the thickness resulting from the coating process (see [D.3](#)).

D.2 Geometrical relationship between coating thickness and pitch diameter

When a coating with theoretical/reference coating thickness t is to be applied on an external ISO metric thread, the pitch diameter d_2 will increase by $4t$ as shown in [Figure D.1](#) and [Table D.1](#).

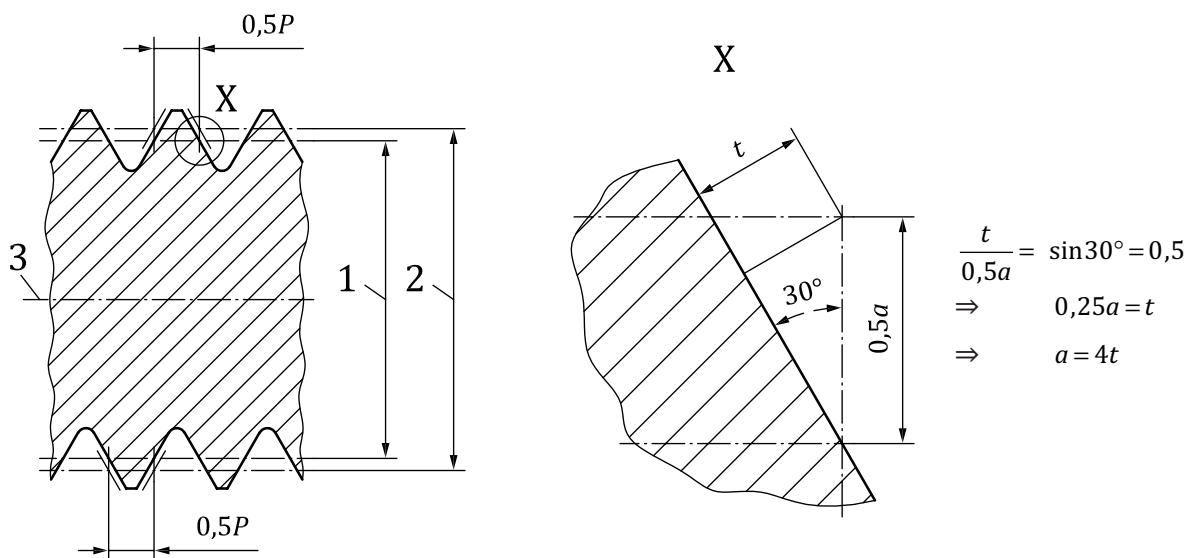

Key

- a change of pitch diameter due to coating
- P pitch of the thread
- t thickness of the coating
- 1 pitch diameter of the bolt before coating, d_2
- 2 pitch diameter of the bolt after coating
- 3 thread axis

Figure D.1 — Geometrical relationship between coating thickness and pitch diameter of an external ISO metric thread

Table D.1 — Geometrical relationship between coating thickness and pitch diameter

Dimensions in micrometres

Coating thickness t	Resulting increase of the pitch diameter $4t^a$
3	12
4	16
5	20
6	24
8	32
10	40
12	48

^a The minimum clearance needed to accommodate the coating thickness t corresponds to the pitch diameter increase, $4t$.

Figure D.2 gives examples of clearance required in the thread of a bolt/nut assembly M8 to accommodate a coating thickness of 6 μm .

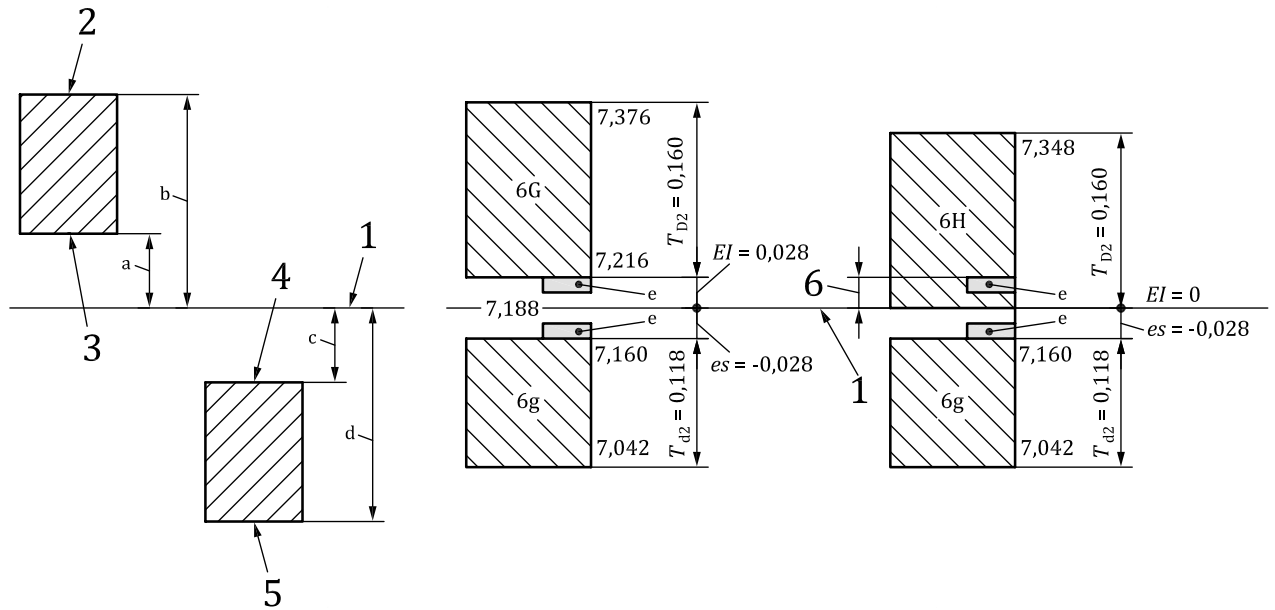

a) Internal/external thread

b) Examples for (6g/6G) and (6g/6H)

Key

- 1 zero line
- 2 maximum pitch diameter of the nut thread before coating
- 3 minimum pitch diameter of the nut thread before coating
- 4 maximum pitch diameter of the bolt thread before coating
- 5 minimum pitch diameter of the bolt thread before coating
- 6 manufactured clearance (tolerance not completely used until the lower limit of 6H)
- T_{D2} tolerance for D_2
- T_{d2} tolerance for d_2
- EI lower limit of the fundamental deviation of the nut thread with respect to zero line
- es upper limit of the fundamental deviation of the bolt thread with respect to zero line
- a, c The minimum clearance corresponds to the fundamental deviation.
- b, d The maximum clearance corresponds to the absolute value of the fundamental deviation plus the tolerance grade value.
- e Coating thickness of 6 μm , needing a minimum clearance of $4 \times 6 \mu\text{m} = 24 \mu\text{m}$ at the pitch diameter before coating.

Figure D.2 — Pitch diameter tolerance position and thread clearance for coating

D.3 Coating thickness on externally threaded fasteners

In electroplating processes, coating thickness depends on the electrical current being applied, and the resulting current density on the surface of individual parts receiving the coating. Current density is not distributed uniformly on a given part; its distribution depends on the shape and geometry of that part. With fasteners, the extremities are high current density locations, and the middle is the low current density location. Consequently, coating thickness on an individual fastener tends to be greater at the extremities (head and end). In contrast, the mid-length and cavities such as holes, internal drives and recesses, which are the low current density areas, receive a lower coating thickness. This phenomenon, known as the dog bone effect is accentuated with increasing length and decreasing diameter of fasteners such as bolts and screws. See [Figure D.3](#).

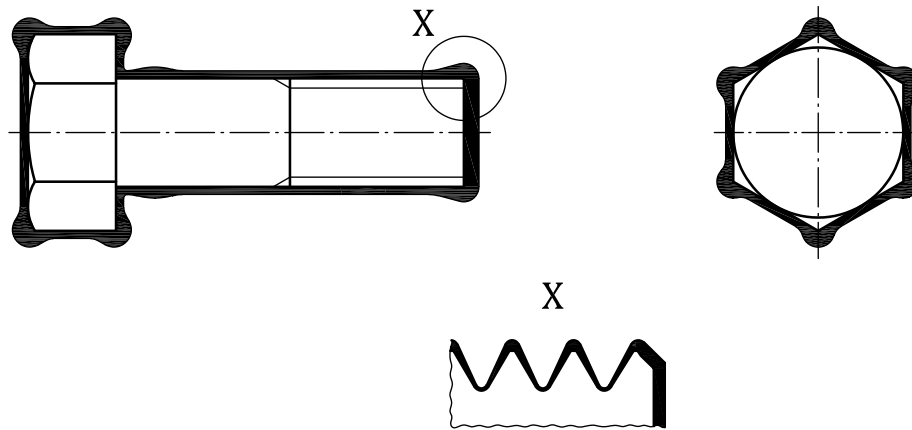

Figure D.3 — Typical distribution of coating thickness on a bolt resulting from electroplating process (exaggerated for illustrative purposes)

For fasteners with external thread, the dog-bone effect typically depends on the ratio between length l and diameter d . Typically, bolts and screws with $l > 5d$ could have a local thickness at mid-length down to one third to half when compared to local thickness at the reference areas shown in [Figure 2](#).

Increasing the specified minimum coating thickness (to have sufficient coating thickness at mid-length of a long bolt —typically $10d$ to $15d$ — for the purpose of corrosion protection), may result in excessive coating thickness at the threaded end, thus impairing ease of assembly and/or GO Gauge acceptance. On the other hand, decreasing the specified minimum coating thickness ensures easy assembly, but may result in insufficient coating thickness at mid-length. The coater shall exercise know-how to manage the process variables to minimize the dog-bone effect while ensuring both adequate corrosion protection and ease of assembly.

D.4 Coating thickness on internally threaded fasteners

Electroplating does not deposit the same coating thickness on external surfaces in comparison with internal surfaces such as internal threads.

A principle of electroplating is that the distribution of metal coating thickness is proportional to the local current density during the electroplating process. The expected metal coating thickness in internal threads also depends of the nut geometry, i.e. relative height of the nut compared to thread diameter. Different kinds of electrolyte (e.g. acidic or alkaline) can result in different thickness distribution (or even uncoated areas in internal threads). Typically, the use of alkaline electrolytes results in more uniform metal distribution.

NOTE However, contrary to the above, significant quantity of coating can be deposited in internal threads by using specific electroplating processes.

In practice for electroplated zinc or zinc-alloy coatings, it is possible to use the tolerance position 6H for internal metric threads before coating, provided the tolerance zone is not taken up to the zero line (basic size). If nuts are to be coated by a third party, functional thread assemblability should be checked.

Additional surface layers such as sealants, top coats and/or lubricants applied with a dip-spin process can result in material retention in internal threads. If this would not allow the acceptance of a 6H GO-gauge, 6G thread tolerance position of the uncoated nut should be considered.

D.5 Clearance for coating thickness

D.5.1 Fasteners with external thread

Fasteners with external thread should be manufactured to provide sufficient clearance at the pitch diameter to accommodate the coating thickness.

Coating thickness which can be applied on ISO metric external threads in accordance with ISO 965-1, ISO 965-2 or ISO 965-3 depends on the fundamental deviation (clearance) at the pitch diameter as given in [Table D.2](#), which itself depends on the tolerance position g, f or e for external threads.

[Table D.2](#) indicates the fundamental deviation (clearance) as a function of the thread pitch and tolerance position for the uncoated external thread. The minimum and maximum clearances are theoretical values limiting the available space for coating.

Table D.2 — Theoretical minimum clearance and corresponding maximum coating thickness for ISO metric external threads

Thread pitch, <i>P</i> mm	Nominal thread diameter, <i>d</i> (coarse pitch thread) ^a mm	Tolerance position g		Tolerance position f		Tolerance position e	
		Fundamental deviation µm	Coating thickness max. µm	Fundamental deviation µm	Coating thickness max. µm	Fundamental deviation µm	Coating thickness max. µm
0,35	1,6	-19	4	-34	8	—	—
0,4	2	-19	4	-34	8	—	—
0,45	2,5	-20	5	-35	8	—	—
0,5	3	-20	5	-36	9	-50	12
0,6	3,5	-21	5	-36	9	-53	13
0,7	4	-22	5	-38	9	-56	14
0,8	5	-24	6	-38	9	-60	15
1	6 and 7	-26	6	-40	10	-60	15
1,25	8	-28	7	-42	10	-63	15
1,5	10	-32	8	-45	11	-67	16
1,75	12	-34	8	-48	12	-71	17
2	14 and 16	-38	9	-52	13	-71	17
2,5	18, 20 and 22	-42	10	-58	14	-80	20
3	24 and 27	-48	12	-63	15	-85	21
3,5	30 and 33	-53	13	-70	17	-90	22
4	36 and 39	-60	15	-75	18	-95	23
4,5	42 and 45	-63	15	-80	20	-100	25
5	48 and 52	-71	17	-85	21	-106	26
5,5	56 and 60	-75	18	-90	22	-112	28
6	64	-80	20	-95	23	-118	29

NOTE Theoretical upper limit of coating thickness is calculated on the basis of thread dimension which is at the upper limit (external thread) of the respective thread tolerance.

^a Information on nominal diameter for coarse pitch thread is given for convenience only: the determining dimension is the thread pitch *P*.

D.5.2 Fasteners with internal thread

Fasteners with internal thread should be manufactured to provide sufficient clearance at the pitch diameter to accommodate the coating thickness.

Coating thickness which can be applied on ISO metric internal threads in accordance with ISO 965-1, ISO 965-2 or ISO 965-3 depends on the fundamental deviation (clearance) at the pitch diameter as given in [Table D.3](#), which itself depends on the tolerance position H or G for internal thread.

[Table D.3](#) indicates the fundamental deviation (clearance) as a function of the thread pitch and tolerance position for the uncoated internal thread. The minimum and maximum clearances are theoretical values limiting the available space for coating.

Table D.3 — Theoretical minimum clearance and corresponding maximum coating thickness for ISO metric internal threads

Thread pitch, <i>P</i> mm	Nominal thread diameter, <i>D</i> (coarse pitch thread) ^a mm	Tolerance position G		Tolerance position H
		Fundamental deviation µm	Coating thickness max. µm	
0,35	1,6	+19	4	Possible if the uncoated thread of the nut is not manufactured up to the zero line
0,4	2	+19	4	
0,45	2,5	+20	5	
0,5	3	+20	5	
0,6	3,5	+21	5	
0,7	4	+22	5	
0,8	5	+24	6	
1	6 and 7	+26	6	
1,25	8	+28	7	
1,5	10	+32	8	
1,75	12	+34	8	
2	14 and 16	+38	8	
2,5	18, 20 and 22	+42	10	
3	24 and 27	+48	12	
3,5	30 and 33	+53	13	
4	36 and 39	+60	15	
4,5	42 and 45	+63	15	
5	48 and 52	+71	15	
5,5	56 and 60	+75	16	
6	64	+80	20	

NOTE Theoretical upper limit of coating thickness is calculated on the basis of thread dimension which is at the lower limit (internal thread) of the respective thread tolerance.

^a Information on nominal diameter for coarse pitch thread is given for convenience only: the determining dimension is the thread pitch *P*.

D.6 Compatibility between corrosion resistance and clearance

For compatibility between corrosion resistance and clearance, see [Figure D.4](#).

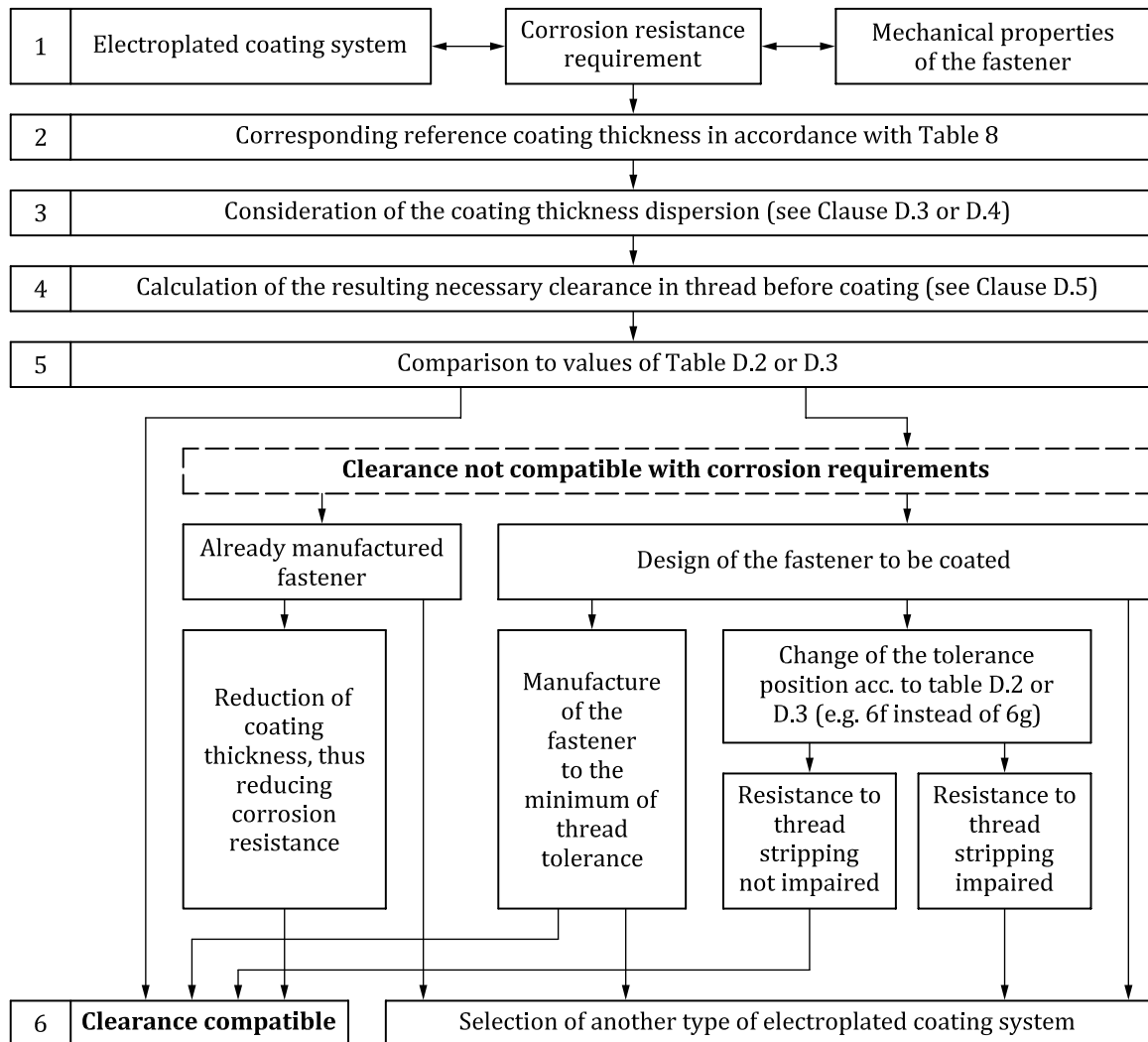

Figure D.4 — Example of checking the compatibility between corrosion resistance and clearance

By choosing a combination of thread tolerance positions for external and internal threads, it should be ensured that the resistance against thread stripping of the assembly is greater than the ultimate tensile load of the external threaded fastener, F_m .

Increased clearance can also affect other functional aspects, such as prevailing torque properties, fatigue resistance, etc.

Annex E (informative)

Coating systems tested in accordance with ISO 9227, NSS — Evaluation of cabinet corrosivity for the neutral salt spray test

E.1 Introduction

When evaluation of the cabinet corrosivity is requested, it should be performed in accordance with this annex.

This annex is designed to be used in addition to the test method specified in ISO 9227 for neutral salt spray test. It has been established for the evaluation of steel fasteners with zinc-based coatings, for the purpose of controlling manufacturing lots.

The main reason for this development as a complement to ISO 9227 was the necessary improvement in terms of reliability, reproducibility and reduction of dispersion of test results, as neutral salt spray test is used for acceptance of fastener production by:

- using the same evaluation mode (appearance of red rust on zinc-based coated steel reference panels rather than weight loss evaluation), and
- periodic controls of the corrosivity of the test cabinet.

This method is successfully used in the fastener industry and significantly improves the reproducibility of results of different salt spray cabinets.

E.2 Purpose

This annex is a complement to ISO 9227 that specifies a methodology for evaluating the corrosivity of the test cabinet for neutral salt spray test (NSS), for steel fasteners with zinc and zinc alloy electroplated coating systems in accordance with this document.

Two types of tests are defined in order to:

- determine the corrosivity level as a grade and the conditions under which the cabinet is considered compliant, by controlling the cabinet corrosivity throughout the useful volume, independently of tested specimens;
- monitor the cabinet corrosivity between periodic controls.

E.3 Frequency of controls

The determination of the corrosivity level shall be carried out at least once a year, and also prior to the use of the cabinet following major maintenance or repair work on the equipment.

The corrosivity monitoring shall be carried out at least once a month.

E.4 Operating conditions

E.4.1 Parameters

All parameters specified in ISO 9227 shall be checked, except the method for evaluating the cabinet corrosivity.

E.4.2 Reference panels

The reference panels shall be made of steel, e.g. CR24 in accordance with ISO 6932, coated at least on one surface with a layer of zinc obtained by high-speed continuous hot dip galvanizing. The zinc thickness shall be $(11 \pm 1) \mu\text{m}$.

The dimensions of the reference panels shall be 190 mm × 90 mm; see [Figure E.4](#).

The reference panels may be oiled for better protection in storage.

The reference panels shall be accompanied by an inspection certificate containing at least the following:

- the identification of the supplier;
- the identification of the reference panels (coil and cast number);
- the chemical composition and mechanical properties of the substrate metal;
- the measured thickness of the zinc deposit;
- the reference of the protective oil, if any.

E.4.3 Preparation of the reference panels

E.4.3.1 Degreasing procedure

The reference panels shall be used within 24 h after the degreasing procedure has been completed. They shall be degreased as follows:

- a) Pre-degrease with acetone using a soft cloth.
- b) Degrease with ultrasonics in a cleaning solution make-up of the following:
 - sodium bicarbonate (NaHCO_3) $(15 \pm 2) \text{ g/l}$;
 - sodium carbonate (Na_2CO_3) $(10 \pm 2) \text{ g/l}$;
 - trisodium phosphate (Na_3PO_4) $(20 \pm 2) \text{ g/l}$;
 - volume adjusted to one litre with distilled or deionized water.

The service life of this degreasing solution is 36 months in an opaque container and in storage conditions ranging from 0 °C to 40 °C. Store this solution in a sealed container between uses (one litre of this solution is sufficient for a maximum of 5 panels).

Ultrasonic conditions:

- temperature $(45 \pm 2) \text{ °C}$;
 - duration $(7 \pm 1) \text{ min}$.
- c) Remove the panels with tongs before turning off the ultrasonics. Rinse in distilled or deionized water, then in a clean solvent (ethanol or acetone) and finally leave to dry in the air.

E.4.3.2 Panel protection

Degreased panels should be handled wearing gloves. Edges and back of panels should be protected with a suitable adhesive tape (e.g. the brown-coloured PVC tape with a width of 38 mm or 50 mm, or similar adhesive removable protection), as specified in [Figure E.4](#), so that the total exposed surface is 160 mm × 80 mm.

E.4.3.3 Position of reference panels and collectors

The support shall be made of chemically inert material. It shall enable positioning of the panels in line with an angle of $(20 \pm 5)^\circ$ from the vertical, with the unprotected face upwards. The centre of each panel shall be levelled at the mean specimen exposure height.

The number and relative position of the panels depend of the control/monitoring and cabinet design, see [Figures E.1](#) to [E.3](#).

a) Annual control

For annual control, at least three panels shall be used. The panels shall be positioned $\frac{1}{4}$, $\frac{1}{2}$ and $\frac{3}{4}$ of the distance between the spray nozzle and the most distant cabinet wall.

The number of collecting devices shall be the same as the number of panels. The collecting devices shall be located as close as possible to the panels.

b) Monthly monitoring

At least one panel shall be used. The number of collecting devices shall be minimum two or, when the number of panels is greater than two, the number of collecting devices shall be the same as the number of panels:

- for one panel and two collectors: the panel shall be positioned at $\frac{1}{2}$ of the distance between the spray nozzle and the most distant cabinet wall; the first collector shall be positioned as close as possible to the panel, and the second collector shall be positioned at $\frac{3}{4}$ of the distance between the spray nozzle and the most distant cabinet wall;
- for two panels and two collectors: the panels shall be positioned at $\frac{1}{2}$ and $\frac{3}{4}$ of the distance between the spray nozzle and most distant cabinet wall; each collector shall be as close as possible to each panel;
- if the number of panels is greater than two, the rules specified for the annual control apply.

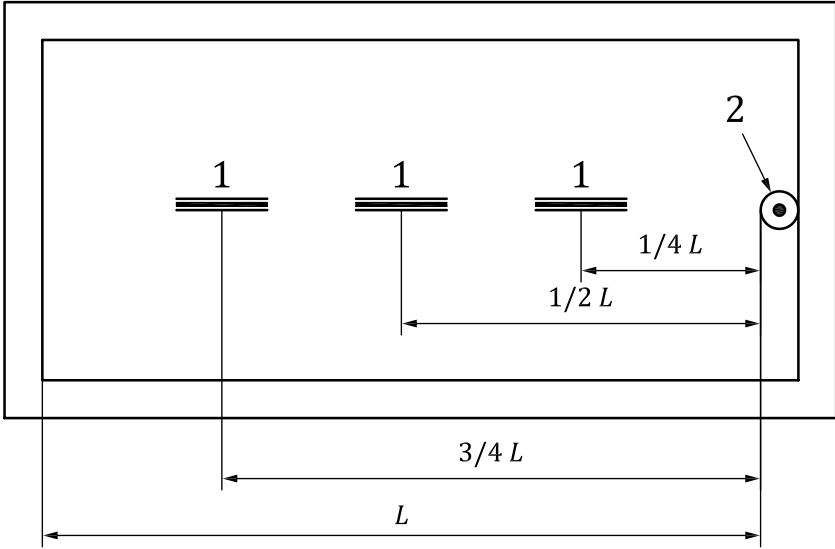

- Key**
- L distance between spray nozzle and the most distant cabinet wall
 - 1 panel
 - 2 spray nozzle

Figure E.1 — Off-centred spray cabinet

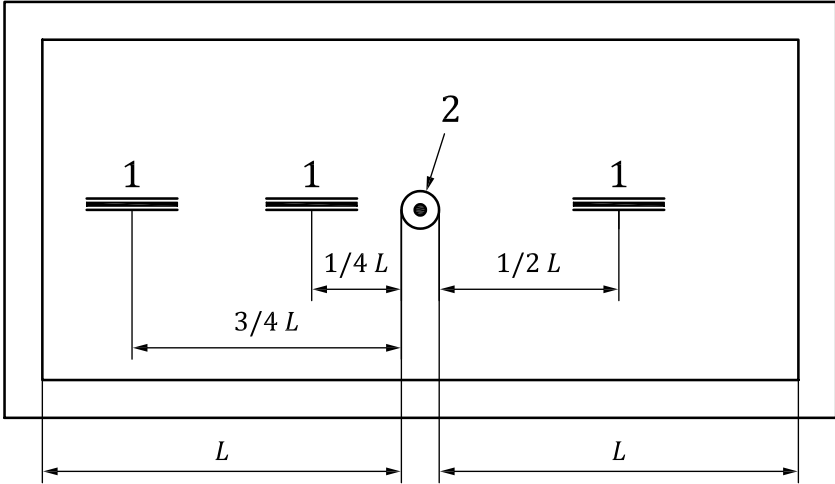

- Key**
- L distance between spray nozzle and the most distant cabinet wall
 - 1 panel
 - 2 spray nozzle

Figure E.2 — Centred spray cabinet

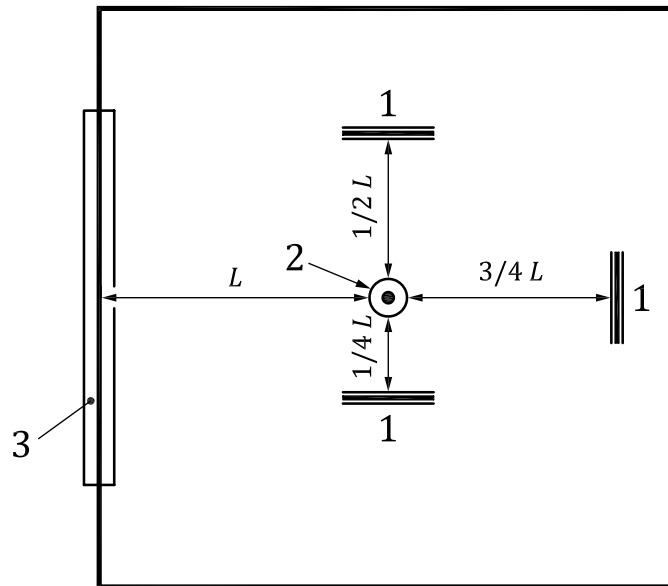

Key

- L distance between spray nozzle and the most distant cabinet wall
- 1 panel
- 2 spray nozzle
- 3 door

Figure E.3 — Square-centred spray cabinet

E.4.3.4 Filling of the cabinet

The test panels shall be arranged so that they do not come into contact with the cabinet walls, and so that their surfaces are exposed to free circulation of salt spray.

During the annual control, the cabinet shall only contain the reference panels.

Monthly monitoring may be conducted during normal operation of the cabinet. The other exposed specimens shall not obstruct the reference panel.

E.4.4 Control mask

The control mask specified in [Figure E.4](#) shall be reproduced to scale on a transparent foil. The mask shall be placed on the reference panels.

Dimensions in millimetres

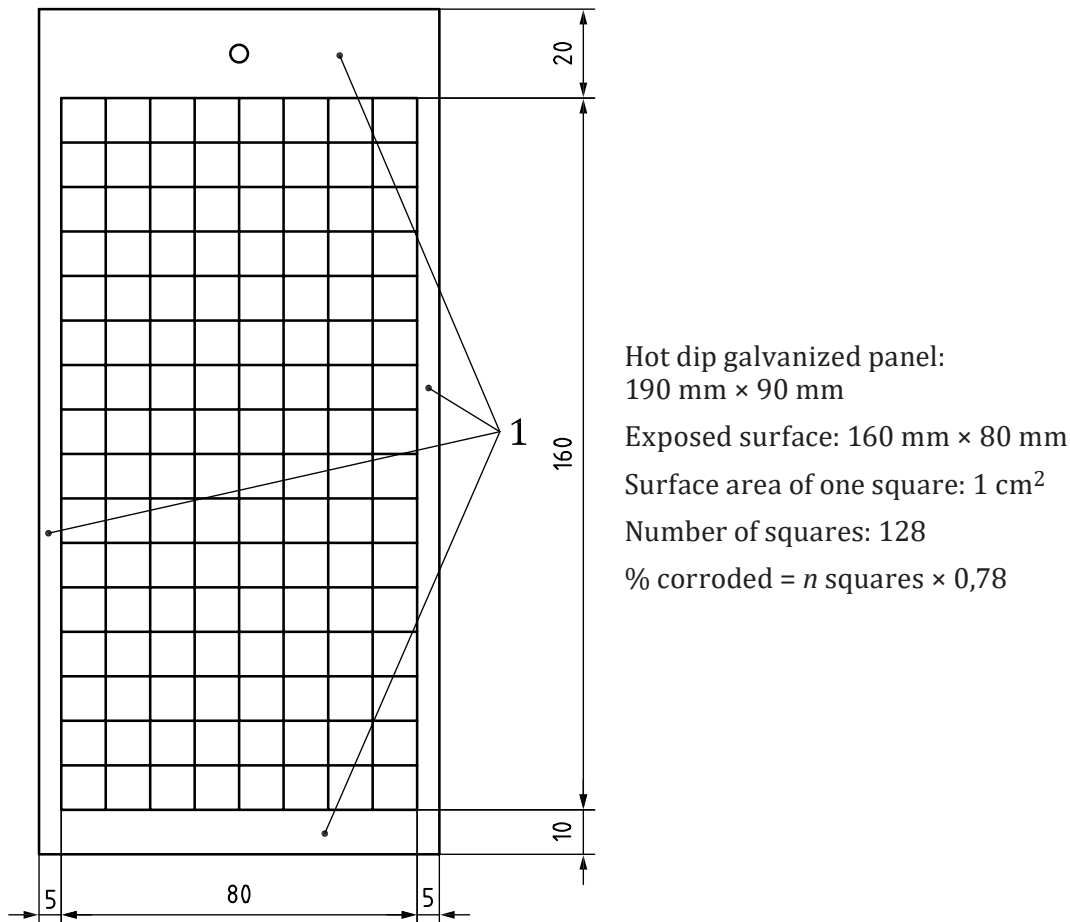

Key

1 protected zone (see [E.4.3.2](#))

Figure E.4 — Protection and control mask for reference panels

E.4.5 Determination of the corroded surface

A square is reported to be corroded as soon as it shows one point of red rust (flow included). See examples in [Figure E.5](#).

All visual checks shall be made on non-rinsed, still wet panels.

The final check shall be started after a period of 70 h to 72 h and then be repeated every (24 ± 1) h. For practical aspects, it is recommended to start the test on Friday.

If one of the panels shows evidence of red rust above 5 % during the 72 h check, it is necessary to reduce the corrosivity of the cabinet and restart the test with new panels (e.g. the following Monday and by checking them every 24 h).

For the annual control, the cabinet shall be open during 30 min per day after the initial period of 72 h. For the monthly monitoring, each opening shall not exceed 60 min. The open duration shall not be deducted.

E.4.6 Quantification of corrosivity

The top of the mask shall be placed exactly at the top of each reference panel in accordance with its orientation in the cabinet during the test.

An example of quantification of corrosivity is shown in [Figure E.5](#).

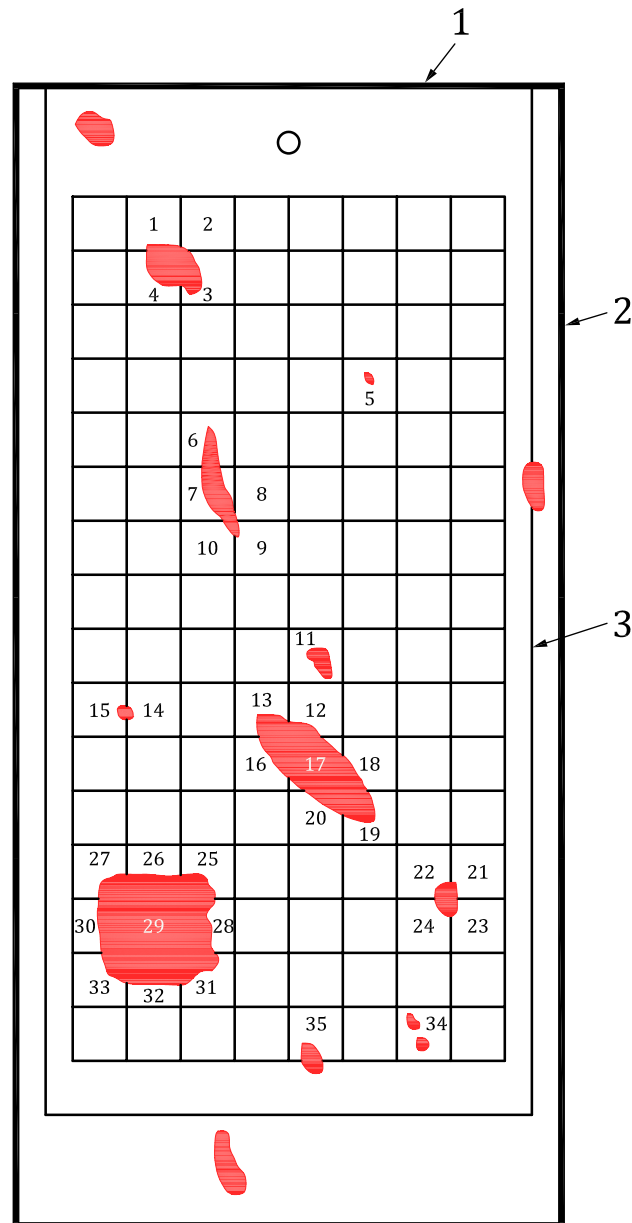

Key

- 1 top of the mask and top of the panel
- 2 reference panel
- 3 control mask

35 squares showing red rust: the percentage of corrosion (red rust rate – RRR) is 27,3 % (35 × 0,78)

Figure E.5 — Example of quantification of the corrosivity

E.5 Corrosivity results

Red rust time (RRT) is the time taken for the rusting level to exceed 5 % (i.e. a minimum of seven squares showing red rust).

RRT for each test panel and the corresponding grade shall be expressed in accordance with [Table E.1](#). See also the examples in [E.6.5](#).

Table E.1 — Grading system for the evaluation of the corrosivity level

Red rust time (RRT) h	Grade	Corrosivity evaluation
$RRT \leq 72$	A	Not compliant
$72 < RRT \leq 96$	B	Compliant
$96 < RRT \leq 120$	C	
$RRT > 120$	D	Not compliant

For corrosivity evaluation, the cabinet is compliant for the purpose of testing steel fasteners with zinc and zinc-based coating systems, when the grade of each panel is equal to B or C in accordance with [Table E.1](#).

The cabinet corrosivity is expressed by using the same grading system of A to D in accordance with [Table E.1](#).

NOTE When testing coated fasteners with several cabinets (e.g. at purchaser's and supplier's places), reliable consistent results can only be achieved when the corrosivity level is compliant in accordance with [Table E.1](#).

E.6 Example of report format for annual control and monthly monitoring of the cabinet

E.6.1 Annual control and monthly monitoring of the cabinet corrosivity level

Type of test:	Monthly monitoring <input type="checkbox"/>	Annual control <input type="checkbox"/>
Test start date:	Cabinet identification number:	
Reference panel batch number:		

E.6.2 Condensate check

Volume collected in ml/h		
Collector 1 ^a	Collector 2 ^a	Collector 3 ^a

^a Average measurement over the entire test duration (opening time included); in accordance with ISO 9227, (1,5 ± 0,5) ml/h for a horizontal collecting area of 80 cm² (which corresponds to one collecting device of 10 cm in diameter).

E.6.3 Determination of the corrosivity level

Red rust time (RRT) h	Grade	Evidence of red rust: % quantified with the control mask		
		Panel 1	Panel 2	Panel 3
RRT ≤ 72	A			
72 < RRT ≤ 96	B			
96 < RRT ≤ 120	C			
RRT > 120	D			
Result (grade when red rust rate RRR > 5 %, see E.5)				

E.6.4 Conclusion for the corrosivity of the cabinet

Conformity of all parameters <input type="checkbox"/>	Non conformity <input type="checkbox"/>
Comments:	
Operator name:	Date:
Signature:	

E.6.5 Examples for the determination of the corrosivity level

Examples for determination of the corrosivity level are given in [Tables E.2](#) and [E.3](#).

Table E.2 — Example 1: Compliant cabinet

Red rust time (RRT) h	Grade	Evidence of red rust: % quantified with the control mask		
		Panel 1	Panel 2	Panel 3
$RRT \leq 72$	A	Red Rust: 0 square —	Red Rust: 1 square 0,78 %	Red Rust: 0 square —
$72 < RRT \leq 96$	B	Red Rust: 3 squares (3 × 0,78 =) 2,3 %	Red Rust: 8 squares (8 × 0,78 =) 6,2 %	Red Rust: 10 squares (10 × 0,78 =) 7,8 %
$96 < RRT \leq 120$	C	Red Rust: 7 squares (7 × 0,78 =) 5,5 %	Red Rust: 12 squares (12 × 0,78 =) 9,4 %	Red Rust: 20 squares (20 × 0,78 =) 15,6 %
$RRT > 120$	D	—	—	—
Result (grade when red rust rate RRR > 5 %, see E.5)		C	B	B
	Corrosivity level: compliant			

Table E.3 — Example 2: Non-compliant cabinet

Red rust time (RRT) h	Grade	Evidence of red rust: % quantified with the control mask		
		Panel 1	Panel 2	Panel 3
$RRT \leq 72$	A	Red Rust: 0 square —	Red Rust: 0 square —	Red Rust: 0 square —
$72 < RRT \leq 96$	B	Red Rust: 1 square 0,78 %	Red Rust: 3 squares (3 × 0,78 =) 2,3 %	Red Rust: 10 squares (10 × 0,78 =) 7,8 %
$96 < RRT \leq 120$	C	Red Rust: 3 squares (3 × 0,78 =) 2,3 %	Red Rust: 7 squares (7 × 0,78 =) 5,5 %	Red Rust: 20 squares (20 × 0,78 =) 15,6 %
$RRT > 120$	D	Red Rust: 7 squares (7 × 0,78 =) 5,5 %	Red Rust: 15 squares (15 × 0,78 =) 11,7 %	Red Rust: 35 squares (35 × 0,78 =) 27,3 %
Result (grade when red rust rate RRR > 5 %, see E.5)		D	C	B
	Corrosivity level: not compliant			

Annex F (informative)

Obsolete designation codes for electroplated coating systems on fasteners according to ISO 4042:1999

WARNING — This system shall not be used for new applications; it is only included for information and for referral to existing drawings and documents still using this system. The designation code system as specified in [Clause 9](#) shall be used instead.

F.1 Obsolete code system

Obsolete designation codes for electroplated coating systems on fasteners according to ISO 4042:1999 are given in [Table F.1](#).

Table F.1 — Obsolete code system

		X	X	X
Coating metal or alloy (see Table F.2)	_____			
Minimum coating thickness (see Table F.3)	_____	_____		
Finish and chromate treatment (see Table F.4)	_____	_____	_____	

Table F.2 — Coating metal or alloy

Coating metal/alloy		Obsolete designation
Symbol	Elements	
Zn	Zinc	A
Cd ^a	Cadmium	B
Cu	Copper	C
CuZn	Brass	D
Ni ^b	Nickel	E
Ni b Cr r ^b	Nickel-chromium	F
CuNi b ^b	Copper-nickel	G
CuNi b Cr r ^b	Copper-nickel-chromium ^c	H
Sn	Tin	J
CuSn	Copper-tin (bronze)	K
Ag	Silver	L
CuAg	Copper-silver	N
ZnNi	Zinc-nickel	P
ZnCo	Zinc-cobalt	Q
ZnFe	Zinc-iron	R

^a Cadmium is restricted or prohibited for many applications (remaining cadmium users are predominantly military and aerospace industries).

^b For ISO classification code, see ISO 1456.

^c Thickness of chromium approximately 0,3 µm.

Table F.3 — Coating thickness (total deposit thickness)

Coating thickness µm		Obsolete designation
One coating metal	Two coating metals ^a	
No coating thickness required	—	0
3	—	1
5	2 + 3	2
8	3 + 5	3
10	6 + 4	9
12	8 + 4	4
15	10 + 5	5
20	8 + 12	6
25	10 + 15	7
30	12 + 18	8

^a The thickness specified for the first and the second coating metal applies for all coating combinations except that chromium is the top coating which has always a thickness of 0,3 µm.

Table F.4 — Finish and chromate treatment

Finish	Passivation by chromate treatment ^a : typical colour	Obsolete designation
Dull	no colour	A
	bluish to bluish iridescent ^b	B
	yellowish gleaming to yellow-brown, iridescent	C
	drab olive to olive brown	D
Semi-bright	no colour	E
	bluish to bluish iridescent ^b	F
	yellowish gleaming to yellow-brown, iridescent	G
	drab olive to olive-brown	H
Bright	no colour	J
	bluish to bluish iridescent ^b	K
	yellowish gleaming to yellow-brown, iridescent	L
	drab olive to olive-brown	M
High-bright	no colour	N
Optional	like B, C or D	P
Dull	brown-black to black	R
Semi-bright	brown-black to black	S
Bright	brown-black to black	T
All finishes	no chromate treatment ^c	U
^a Passivation treatments are possible only with zinc or cadmium coatings. ^b Applies to zinc coating only. ^c Example for such a coating: A5U.		

F.2 Example of obsolete designation

EXAMPLE Fastener with electroplated zinc coating (A from [Table F.2](#)), a required coating thickness of 5 µm (2 from [Table F.3](#)), brightness condition “bright”, being chromated yellow iridescent (L from [Table F.4](#)) was designated as follows:

[fastener designation] – **A2L**

In the case that this obsolete designation is used, the following applies:

- If no minimum coating thickness is explicitly required, then the symbol “0” of the coating thickness according to [Table F.3](#) is indicated in the code number —for example A0P— so that the code number contains complete specifications. Symbol “0” applies correspondingly to threaded parts below M1,6 or other very small parts.
- If other treatments are required, for example greased or oiled, this is agreed upon. If applicable, this treatment is added to the designation as clear text.

Bibliography

- ISO 898-1, *Mechanical properties of fasteners made of carbon steel and alloy steel — Part 1: Bolts, screws and studs with specified property classes — Coarse thread and fine pitch thread*
- ISO 898-2, *Mechanical properties of fasteners made of carbon steel and alloy steel — Part 2: Nuts with specified property classes — Coarse thread and fine pitch thread*
- ISO 898-3, *Mechanical properties of fasteners made of carbon steel and alloy steel — Part 3: Flat washers with specified property classes*
- ISO 898-5, *Mechanical properties of fasteners made of carbon steel and alloy steel — Part 5: Set screws and similar threaded fasteners with specified hardness classes — Coarse thread and fine pitch thread*
- ISO 965-1, *ISO general purpose metric screw threads — Tolerances — Part 1: Principles and basic data*
- ISO 965-2, *ISO general purpose metric screw threads — Tolerances — Part 2: Limits of sizes for general purpose external and internal screw threads — Medium quality*
- ISO 965-3, *ISO general purpose metric screw threads — Tolerances — Part 3: Limit deviations for screw threads*
- ISO 1478, *Tapping screws thread*
- ISO 2702, *Heat-treated steel tapping screws — Mechanical properties*
- ISO 6932, *Cold-reduced carbon steel strip with a maximum carbon content of 0,25 %*
- ISO 10666, *Drilling screws with tapping screw thread — Mechanical and functional properties*
- ISO 16426, *Fasteners — Quality assurance system*
- ISO/TR 20491, *Fasteners — Fundamentals of hydrogen embrittlement in steel fasteners*
- ISO 22479, *Corrosion of metals and alloys — Sulfur dioxide test in a humid atmosphere (fixed gas method)*
- ASTM F606/F606M, *Standard test methods for determining the mechanical properties of externally and internally threaded fasteners, washers, direct tension indicators, and rivets*
- ASTM F1940, *Standard test method for process control verification to prevent hydrogen embrittlement in plated or coated fasteners*
- DIN 50969-2, *Prevention of hydrogen-induced brittle fracture of high-strength steel building elements — Part 2: Test methods*
- NASM 1312-2, *Fastener test methods — Method 2 — Interaction*

Bureau of Indian Standards

BIS is a statutory institution established under the *Bureau of Indian Standards Act, 2016* to promote harmonious development of the activities of standardization, marking and quality certification of goods and attending to connected matters in the country.

Copyright

BIS has the copyright of all its publications. No part of these publications may be reproduced in any form without the prior permission in writing of BIS. This does not preclude the free use, in the course of implementing the standard, of necessary details, such as symbols and sizes, type or grade designations. Enquiries relating to copyright be addressed to the Head (Publication & Sales), BIS.

Review of Indian Standards

Amendments are issued to standards as the need arises on the basis of comments. Standards are also reviewed periodically; a standard along with amendments is reaffirmed when such review indicates that no changes are needed; if the review indicates that changes are needed, it is taken up for revision. Users of Indian Standards should ascertain that they are in possession of the latest amendments or edition by referring to the website-www.bis.gov.in or www.standardsbis.in.

This Indian Standard has been developed from Doc No.: PGD 37 (19630).

Amendments Issued Since Publication

Amend No.	Date of Issue	Text Affected

BUREAU OF INDIAN STANDARDS

Headquarters:

Manak Bhavan, 9 Bahadur Shah Zafar Marg, New Delhi 110002

Telephones: 2323 0131, 2323 3375, 2323 9402

Website: www.bis.gov.in

Regional Offices:

Central : 601/A, Konnectus Tower -1, 6th Floor,
DMRC Building, Bhavbhuti Marg, New
Delhi 110002

Telephones

{ 2323 7617

Eastern : 8th Floor, Plot No 7/7 & 7/8, CP Block, Sector V,
Salt Lake, Kolkata, West Bengal 700091

{ 2367 0012
2320 9474

Northern : Plot No. 4-A, Sector 27-B, Madhya Marg,
Chandigarh 160019

{ 265 9930

Southern : C.I.T. Campus, IV Cross Road, Taramani, Chennai 600113

{ 2254 1442
2254 1216

Western : 5th Floor/MTNL CETTM, Technology Street, Hiranandani Gardens, Powai
Mumbai 400076

{ 25700030
25702715

Branches : AHMEDABAD, BENGALURU, BHOPAL, BHUBANESHWAR, CHANDIGARH, CHENNAI, COIMBATORE, DEHRADUN, DELHI, FARIDABAD, GHAZIABAD, GUWAHATI, HARYANA (CHANDIGARH), HUBLI, HYDERABAD, JAIPUR, JAMMU, JAMSHEDPUR, KOCHI, KOLKATA, LUCKNOW, MADURAI, MUMBAI, NAGPUR, NOIDA, PARWANOO, PATNA, PUNE, RAIPUR, RAJKOT, SURAT, VIJAYAWADA.